

5 Gallon Round Container

Features

- Taller height reduces spillage during filling and capping
- Polished surface provides attractive appearance
- Reinforcing ribs maintain container shape
- Tapered design allows for container nesting
- Hot fill capability up to 190°F with appropriate materials and freezer compatible
- Heat transfer decoration and 6 color offset print capability
- In-Mold label (IML) decoration available
- Accepts plastic or metal handle

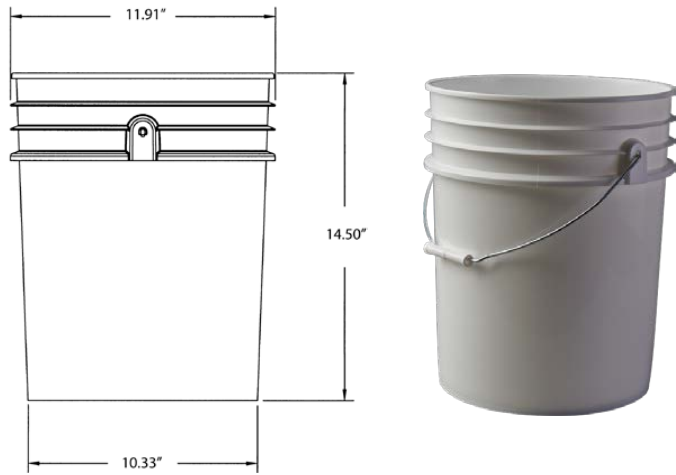

PRODUCT CODE.....5DM (TA5G90DM)

COMPATIBLE LIDS.....5LTB, 5LHV, 5NLR & 5LTEO

SPECIFICATIONS

Height.....14.50"
 Outer Diameter.....11.91"
 Thickness......90 mil
 Print Area.....31" x 8.25"
 Resin.....HDPE

VOLUME

Practical Fill.....5.10 gal. / 19.30 liters
 Overflow.....5.40 gal. / 20.44 liters

PACKAGING

Pack Count.....120
 Pack Dimensions.....48.9" x 36.6" x 49.6"
 Cubic Feet.....51.3
 Packs per Pallet.....2

ORDER QUANTITIES (53' Truckload)

5DM with compatible lids.....6,720 bases & lids

DISCLAIMER

THIS INFORMATION IS PROVIDED AS A GENERAL GUIDE, INCLUDING DIMENSIONS. IT IS THE CUSTOMER'S RESPONSIBILITIES TO SELECT THE PROPER CONTAINER FOR PRODUCT AND APPLICATION COMPATIBILITY.

DISTRIBUTED BY:



REF NO.:

DWG30187

DESCRIPTION:

5 Gallon HDPE OH Pail