

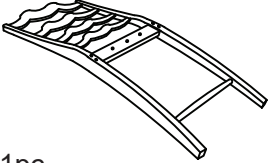

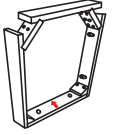

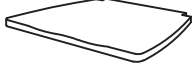

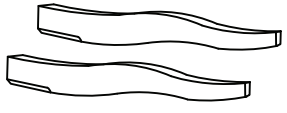

ASSEMBLY INSTRUCTION

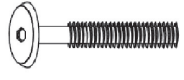
FRENCH LADDER BACK 24"H COUNTER HEIGHT CHAIR

A Chair Back  1pc	B Box Frame  1pc	C Wooden Seat  1pc	D Front Leg (Left-Right)  2pcs
E Stretcher  3pcs	F Jcbc Bolt M6 x 70mm  8pcs	G Jcbc Bolt M6 x 40mm  2pcs	H Spring Washer M6 x 13mm  10pcs
I Flat Washer M6 x 16mm x 2mm  10pcs	J CBS Screw M4 x 25mm  6pcs	K CBS Screw M4 x 38mm  6pcs	L Allen Key M4  1pc
M Glue  1pc			

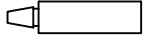
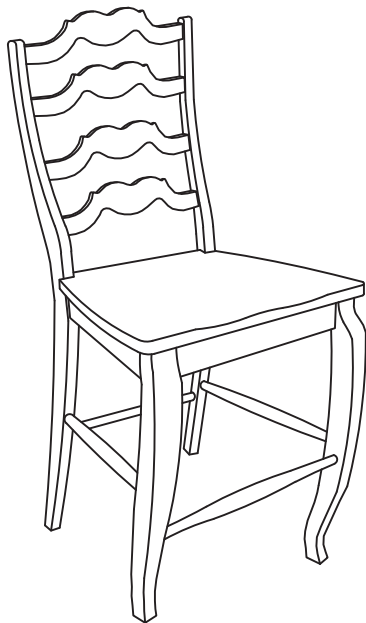

This page lists all the contents included in the box. Please take the time to identify the hardware as well as the individual components to this product. As you unpack and prepare for assembly, place the contents on a carpeted or padded area to protect them from damage.

1

Put the Chair Back (A) and Box Frame (B) upside down on the soft and smooth surface. With assistance attach Box Frame (B) onto Chair Back (A). Then insert Jcbc Bolt (F), Spring Washer (H) and Flat Washer (I) into predrilled holes of each corner by using Allen Key (L). Insert Jcbc Bolt (G), Spring Washer (H) and Flat Washer (I) into the predrilled holes of the middle of Chair Back (A) by using Allen Key (L). Do not fully tighten the bolts in this step.

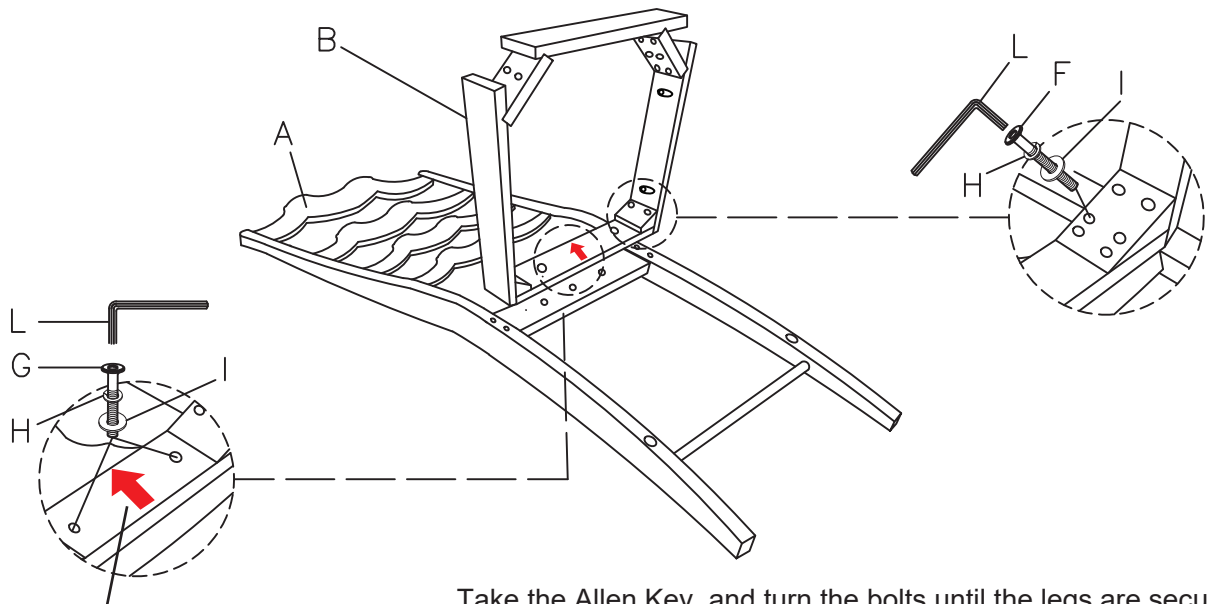

Please make sure arrow on Box Frame (B) was facing upward.

Take the Allen Key, and turn the bolts until the legs are secured.
DO NOT TIGHTEN COMPLETELY.
Stop when you feel you are adding force to tighten the bolt.

2

Apply some Glue (M) to the holes of the Chair Back (A) and insert Stretcher (E) into the holes of Chair Back (A) with CBS Screw (K) by using Screwdriver (not included). Do not fully tighten all screws in this step.

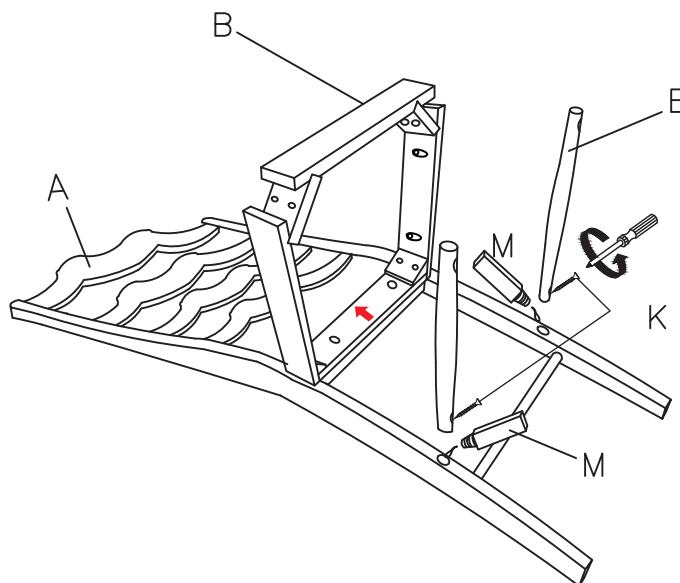

3 Attach Front Leg (D) assembly to corner of Box Frame (B) along inserting the Stretcher (E) onto each hole on Front Leg (D) with applying some Glue (M), then insert Jcbc Bolt (F), Spring Washer (H) and Flat Washer (I) using Allen Key (L).

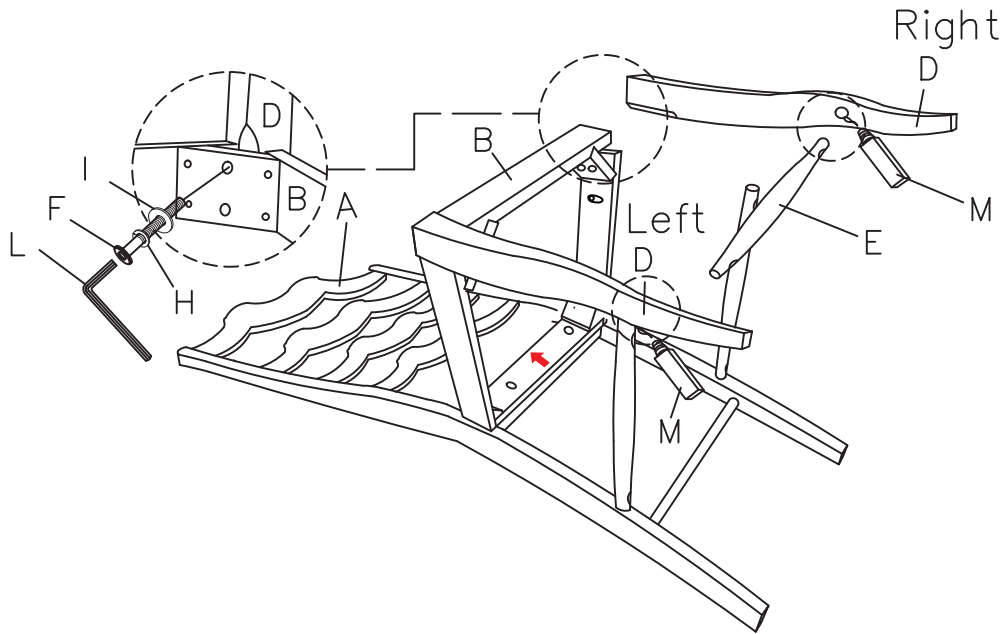

4 Insert CBS Screw (K) into the holes of Front Leg (D) and Stretcher (E) by using Screwdriver (not included).

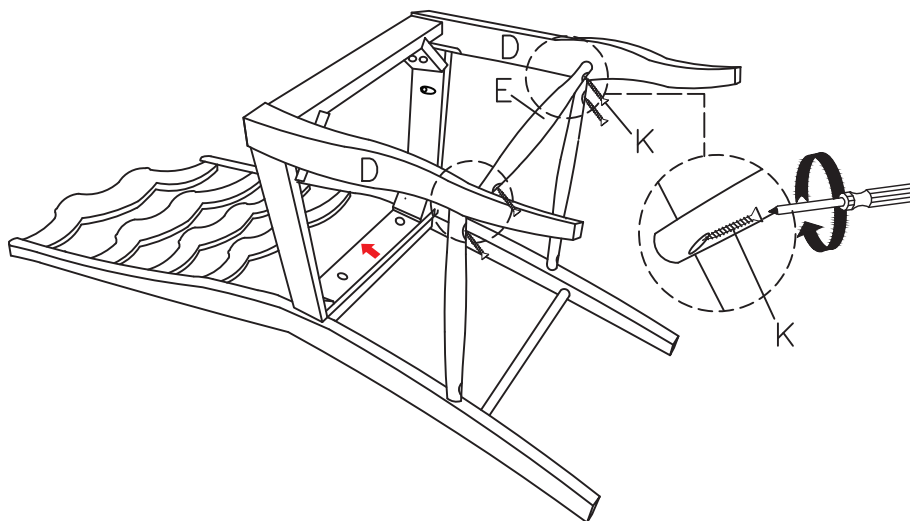

-
- 5** Attach Wooden Seat (C) and Box Frame (B) with CBS Screw (J) by using Screwdriver (not included). Tighten all screws in this step.

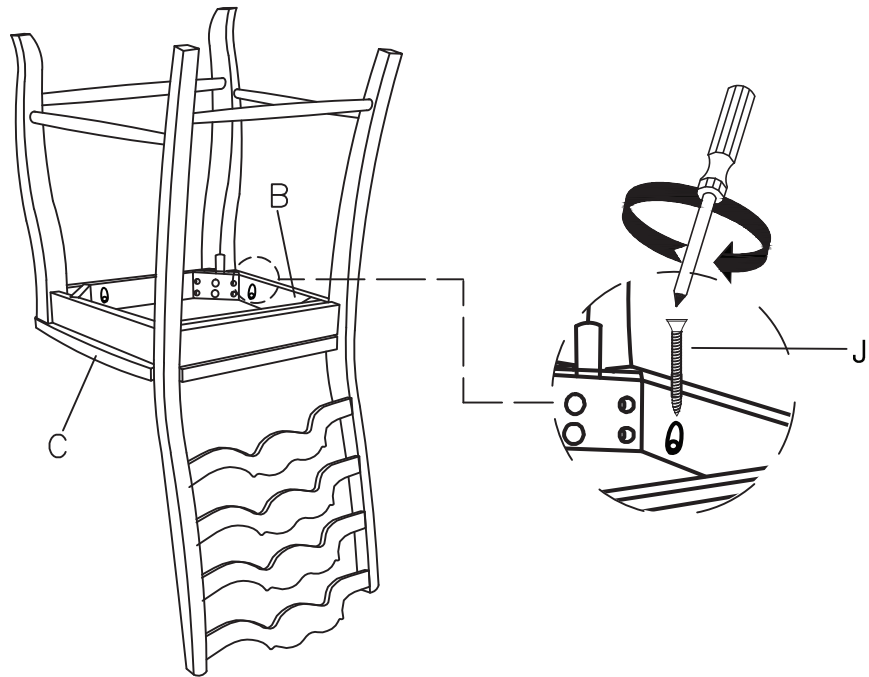

-
- 6** Turn the assembled chair to the upright position carefully. Make sure the chair is level, and then securely tighten all bolts at this stage. Assembly is now completed.

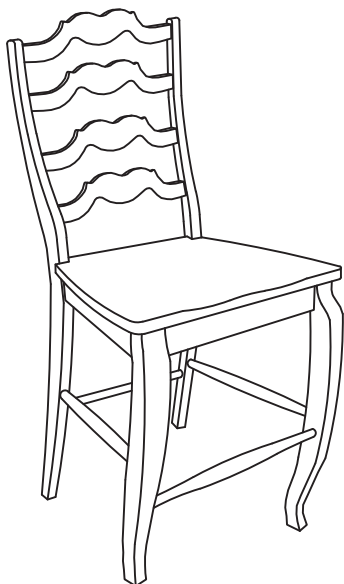

Stand chair up on an even surface and check that it is balanced. If there is a slight wobble, apply downward pressure in the corner where a leg is uneven. Keeping pressure in that corner, tighten all bolts. If balanced, apply downward pressure evenly in the center and tighten all bolts. Do not over-tighten beyond hole depth.

Helpful Tip: Instead of applying downward pressure while reaching under to tighten bolts, have someone sit in the chair while you tighten the bolts.

Cleaning & Care

Treat surface with care. Surface is resistant to scratches but is not scratch resistant. Clean surface with a dry or damp soft cloth. Do not use abrasive cleaners. Hardware may loosen over time. Periodically check that all connections are tight.