



# Assembly Instructions

B1754-110 Maximus 6/6-6/0 K Headboard  
 B1754-120 Maximus 6/6-6/0 K Footboard And Slats  
 B1754-130 Maximus 6/6 EK Side Rails  
 B1754-230 Maximus 6/0 WK Side Rails

Thank you for purchasing this quality product. Be sure to check all packing materials carefully for small parts, which may have come loose inside the carton during shipment. Identify and count all items and compare with the PARTS LIST and/or HARDWARE LIST shown below.

**Caution:** Please read the instructions thoroughly before assembly.

1. We recommend that you assemble this product with the assistance of another person: this will make the assembly easier, and will help eliminate damage to the product or injury to persons during assembly.
2. Please do not over tighten screws or bolts until the assembly is completed.
3. Please put all parts on a non-abrasive floor before assembly, and follow the assembly steps to assemble your newly purchased product correctly and efficiently

## PARTS LIST

NO:	COMPONENT	DRAWING	Q'TY
A	Headboard		1PC
B	Footboard		1PC
C	Side Rail		2PCS
D	Slats		4PCS
E	Left Post		1PC
F	Right Post		1PC
G	Finials		4PCS
H	Burn Feet		2PCS
I	Support Legs		8PCS

## HARDWARE LIST

NO:	COMPONENT	DRAWING	Q'TY
1	Bolt 5/16"x45mmL		6pcs
2	Bolt 5/16"x88mmL		8pcs
3	Flat Washer 5/16"*Ø19mm		6pcs
4	Lock Washer 5/16"		14pcs
5	Half Moon Washer 5/16"		8pcs
6	Nut (5/16")		8pcs
7	Screw: #8*32mm		8pcs
8	Allen key (5mm)65*35mm		1pc
9	Open Wrench 90*12mm		1pc

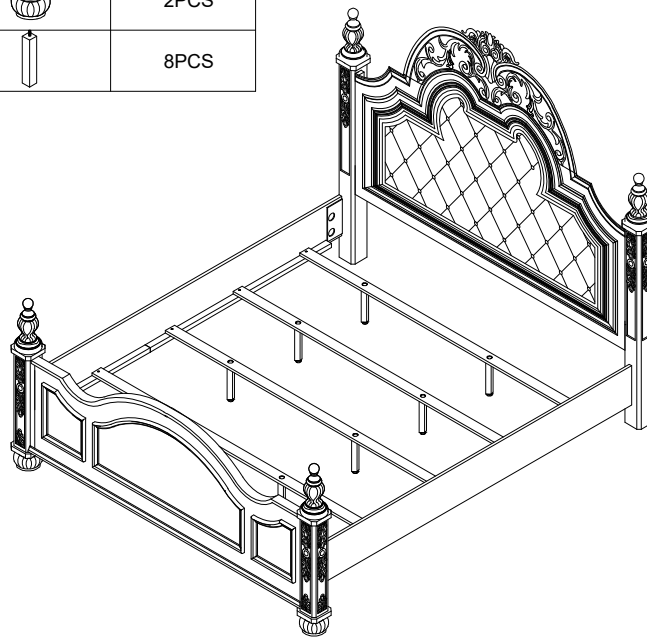



# Assembly Instructions

B1754-110 Maximus 6/6-6/0 K Headboard  
 B1754-120 Maximus 6/6-6/0 K Footboard And Slats  
 B1754-130 Maximus 6/6 EK Side Rails  
 B1754-230 Maximus 6/0 WK Side Rails

## STEP 1

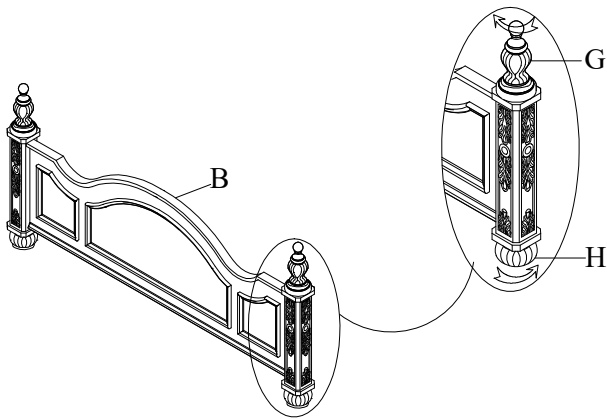

## STEP 2

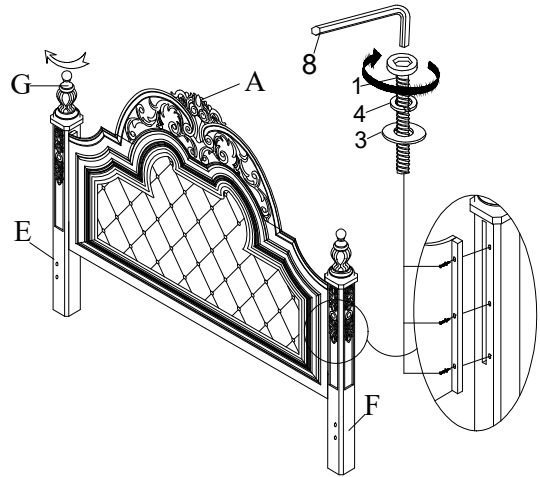

## STEP 3

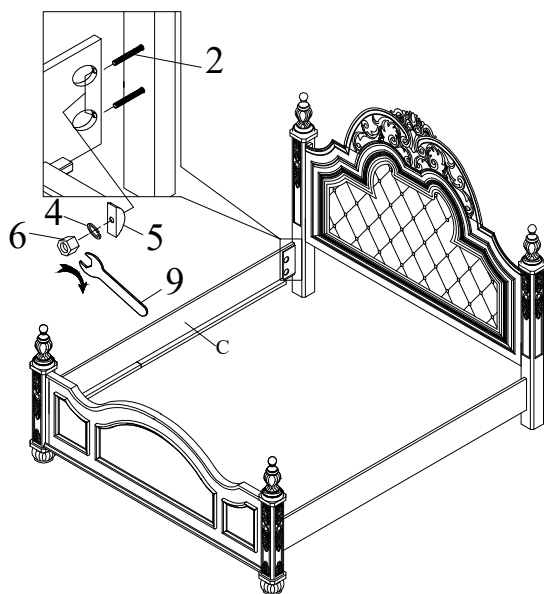

## STEP 4

