

SILVERBACK

54" WALL MOUNT BASKETBALL SYSTEM

MODEL NO.
B8417



**Please Do Not Return This
Product to the Store!**

Contact Escalade® Sports customer service department at:
Phone: 1-888-USA-GOAL Toll-Free!
Fax: 1-866-873-3536 Toll-Free!
E-mail: customerservice@escaladesports.com

ESCALADE®
SPORTS

Escalade® Sports products may be manufactured and/or licensed under the following patents.
6120397, 5816957, 5769744, 5119741, 4911085, 4717157, D460140, D420563, 8414431
Additional patents may be pending. One or more of the listed patents and/or pending patents may cover specific product.

2L-7986-01

2022 Escalade® Sports

PRE - ASSEMBLY TIPS

1. **Read this manual carefully before starting assembly.** Read each step completely before beginning each step.
2. **Some smaller parts may be shipped inside larger parts. Check inside all parts and cartons before assembling or ordering parts.**
3. **To make assembly easier, use the Hardware Identifier on page 6 to identify and sort all fasteners. Check all cartons for kits. All hardware may not be located in one kit.**
4. **Do not tighten hardware until instructed to do so. If hardware is tightened too soon, mounting holes may not align and parts may not easily fit together. Leave locknuts slightly loose until you are instructed to tighten them.**
5. **Save these instructions and your proof of purchase (receipt) in the event that the manufacturer has to be contacted for replacement parts.**

Tools required for assembly:

- 2 Capable Adults
- Carpenters Level
- Pencil or other marking tool
- Masking tape
- 15ft (minimum) Tape Measure
- Step Ladder 8ft minimum (x2)
- 2 each Wrenches and/or Socket Wrenches and Sockets(deep-well sockets are recommended) (extension recommended) 13mm & 16mm
- Phillips Screw Driver



Please Do Not Return This Product To The Store!

Contact Escalade® Sports customer service department at:

Phone: 1-800-USA-GOAL Toll – Free !
 Fax: 1-866-873-3536 Toll – Free !
 E-mail: basketball@escaladesports.com

Escalade Sports

Physical Location: 817 Maxwell Ave. Evansville, IN 47711
Mailing Address: (Correspondence Only) PO Box 889 Evansville, IN 47706

Please visit our Website at:
www.escaladesports.com

ON-LINE TROUBLE SHOOTING TECHNICAL ASSISTANCE
 ON-LINE PARTS REQUESTS FREQUENTLY ASKED QUESTIONS
 ADDITIONAL ESCALADE®SPORTS PRODUCT INFORMATION





WARNING

A SOLID MOUNTING SURFACE, CAPABLE OF WITHSTANDING NORMAL RECREATIONAL USE FORCES, MUST BE PROVIDED BY THE CUSTOMER. A RELIABLE CARPENTER OR BUILDING CONTRACTOR SHOULD BE CONSULTED IF THERE ARE ANY QUESTIONS REGARDING PROCEDURE.



WARNING

CAREFULLY INSPECT MOUNTING AREA FOR STRUCTURAL INTEGRITY AND HIDDEN ELECTRICAL WIRING.



WARNING

MINIMUM DISTANCE SHOULD BE 135.3" FROM TOP OF WALL BRACKET (ITEM #1) TO PLAYING SURFACE. HOMEOWNER MUST ASSUME ALL RESPONSIBILITY FOR ANY PERSONAL OR PROPERTY DAMAGE IF BACKBOARD HEIGHT IS LOWER THAN RECOMMENDED.



WARNING

USE CAUTION: ASSEMBLY IS HEAVY. TWO CAPABLE ADULTS REQUIRED FOR ASSEMBLY. FAILURE TO FOLLOW THIS WARNING COULD RESULT IN SERIOUS INJURY AND/OR PROPERTY DAMAGE.

WARNING

FAILURE TO FOLLOW THESE WARNINGS MAY RESULT IN SERIOUS INJURY AND/OR PROPERTY DAMAGE.

- DO NOT DUNK on this system.
- During play, do not wear jewelry (rings, watches, necklaces, etc.) Objects may entangle in net or other areas of structure.
- Wear mouth guard during playing to avoid dental injuries.
- Do not allow children to adjust the system.
- See pole for additional warnings.
- DO NOT HANG on the rim or any part of system including backboard, support braces or net.
- During play, keep players face away from the backboard, rim, and net. Serious injury could occur if teeth/face encounter backboard, rim, or net.
- When adjusting height, keep hands and fingers away from moving parts.
- Check system BEFORE EACH USE for instability, loose hardware, and signs of corrosion and repair before each use. Never play on damaged equipment.
- Once a month check all metal parts for rust. Completely remove rust and repaint with exterior enamel. If rust has penetrated any steel part, replace that part immediately.
- Do not use this system to lift or hoist anything. The mechanism is designed to lift only the weight of the backboard and rim. Do not hang anything from the handle, rim, backboard, or lifter arms as this will damage the system and void the warranty.

DANGER

- Refer to product manual for assembly instructions. Consult a structural engineer or builder on the mounting of this system and hardware required to do so. Avoid attaching to any brick surface or façade. Improper mounting may cause serious injury or death.
- Owner must ensure that all players know and follow these rules for safe operation of the system.

SAFETY INSTRUCTIONS

FAILURE TO FOLLOW THESE SAFETY INSTRUCTIONS MAY RESULT IN SERIOUS INJURY, PROPERTY DAMAGE AND WILL VOID WARRANTY.

Owner must ensure that all players know and follow these rules for safe operation of the system.

To ensure safety, do not attempt to assemble this system without following the instructions carefully. Proper and complete assembly, use and supervision is essential for proper operation and to reduce the risk of accident or injury. A high probability of serious injury exists if this system is not installed, maintained, and operated properly.

- If using a ladder during assembly, use extreme caution.
- 2 people are recommended for this operation.
- Climate, corrosion or misuse could result in system failure.
- If technical assistance is required, contact the manufacturer.
- Minimum operational height is 6'6" (1.98m) to the bottom of backboard.

*Most injuries are caused by misuse and/or not following instructions.
Use caution when using this system.*

PARTS LIST (NOT ACTUAL SIZE)

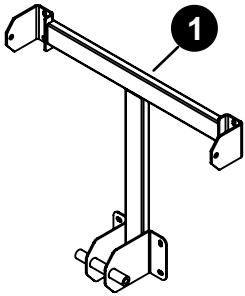

WALL BRACKET
1A-8001-00
QTY. 1

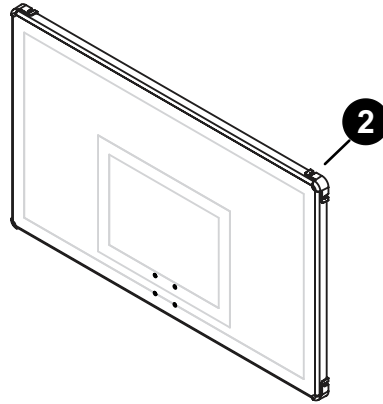

BACKBOARD ASSEMBLY, 54"
4A-8282-20
QTY. 1



MOUNTING CHANNEL, BACKBOARD
1A-7957-20
QTY. 1

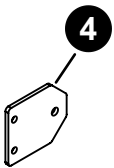

CONNECTOR PLATE
2S-9486-00
QTY. 2

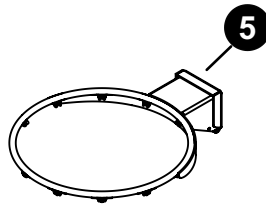

BREAK AWAY RIM ASSEMBLY
4A-8283-20
QTY. 1

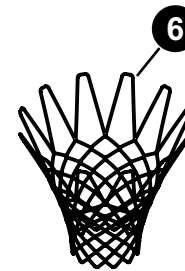

NET
3F-6010-00
QTY. 1

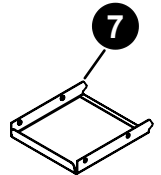

COVER PLATE
2S-9422-20
QTY. 1

HARDWARE LIST (ACTUAL SIZE)

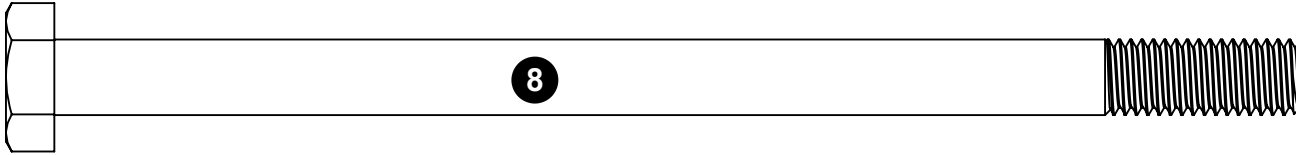

M10-1.5 X 165mm HEX HEAD BOLT
1B-7183-00
QTY. 1

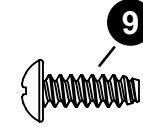

#8 X 1/2" THREAD CUTTING SCREW
1B-6238-01
QTY. 4

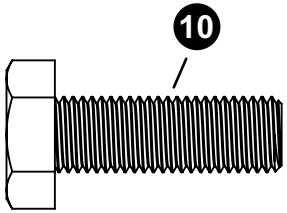

M10-1.25 x 30 HHCS
1B-7239-00
QTY. 2

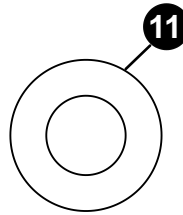

FLAT WASHER M10
2B-6800-00
QTY. 10

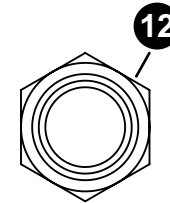

M10-1.5 HEX LOCK NUT
2B-6801-00
QTY. 7

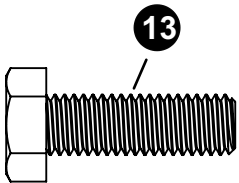

M8-1.25 X 25 HHCS
1B-7170-00
QTY. 4

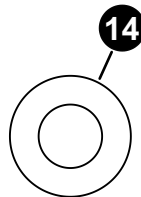

FLAT WASHER M8
2B-6797-00
QTY. 8

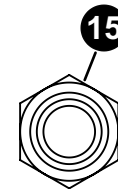

M8-1.25 HEX LOCKNUT
2B-6808-00
QTY. 4

⚠ DANGER

CONSULT A STRUCTURAL ENGINEER OR BUILDER ON THE MOUNTING OF THIS SYSTEM AND HARDWARE REQUIRED TO DO SO. AVOID ATTACHING TO ANY BRICK SURFACE OR FAÇADE. IMPROPER MOUNTING MAY CAUSE SERIOUS INJURY OR DEATH.

⚠ WARNING

MINIMUM DISTANCE SHOULD BE 135.3" FROM TOP OF WALL BRACKET (ITEM #1) TO PLAYING SURFACE. HOMEOWNER MUST ASSUME ALL RESPONSIBILITY FOR ANY PERSONAL OR PROPERTY DAMAGE IF BACKBOARD HEIGHT IS LOWER THAN RECOMMENDED.

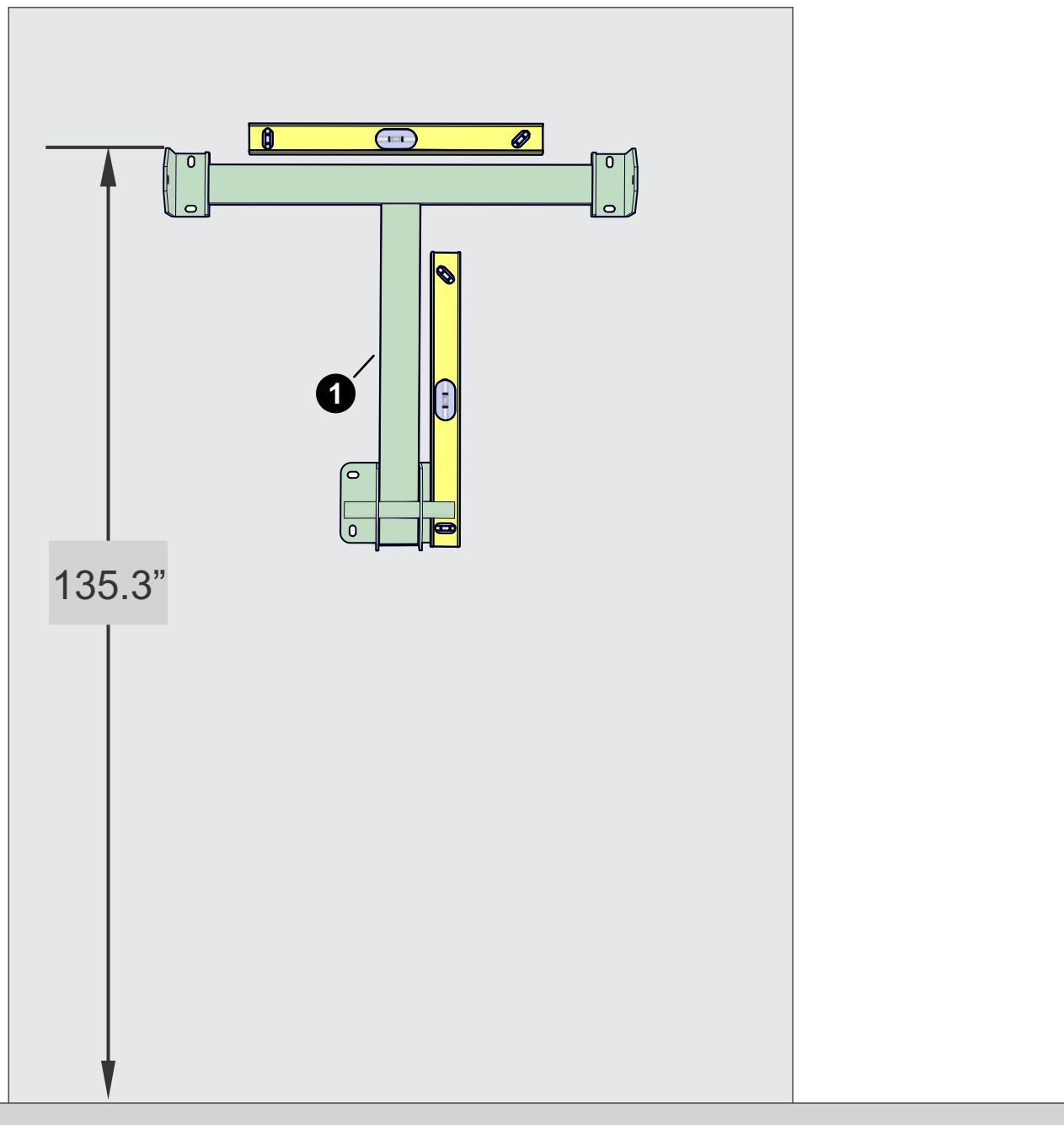

HARDWARE NEEDED (ACTUAL SIZE)

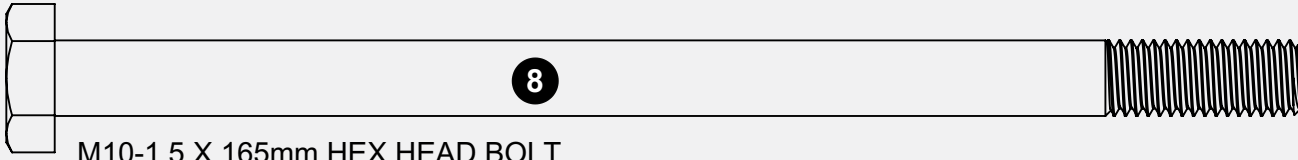

M10-1.5 X 165mm HEX HEAD BOLT
1B-7183-00
QTY. 1

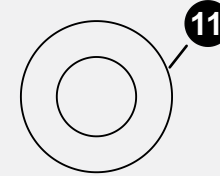

WASHER M10
2B-6800-00
QTY. 2

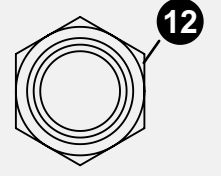

M10-1.5 HEX LOCK NUT
2B-6801-00
QTY. 1

TOOLS NEEDED

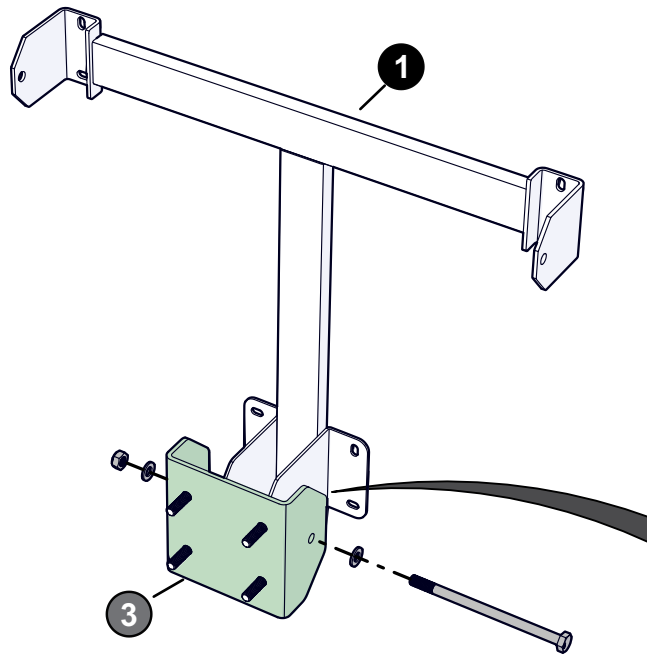
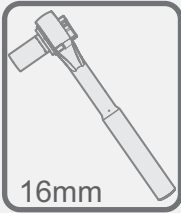
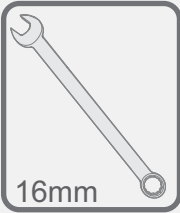

NOTE
Tighten hardware about 3/4ths of the way. Leave loose enough to attach the rest of the parts.

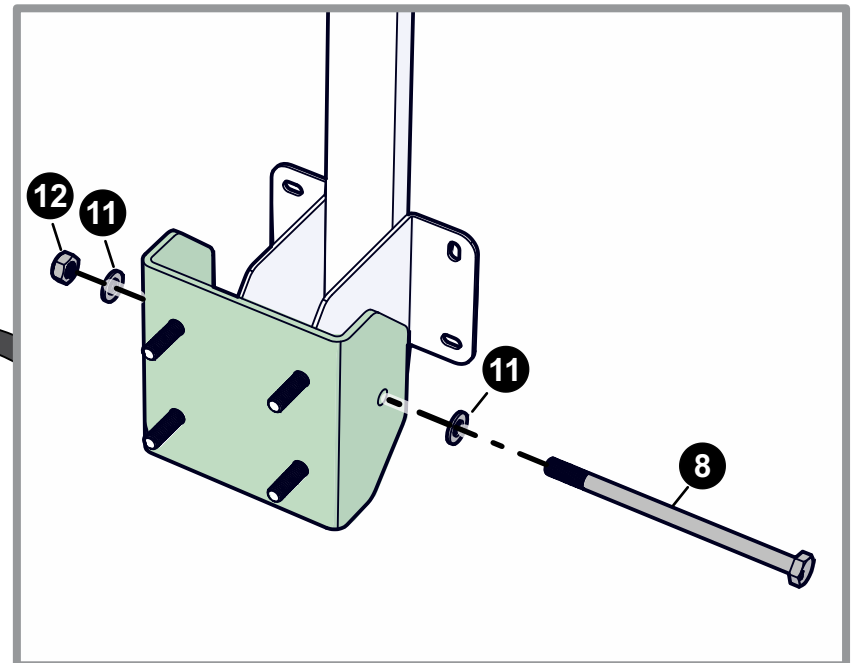

HARDWARE NEEDED (ACTUAL SIZE)

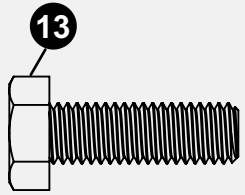

M8-1.25 X 25 HHCS
1B-7170-00
QTY. 4

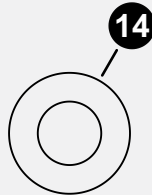

WASHER M8
2B-6797-00
QTY. 8

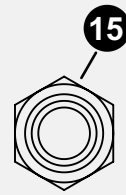

M8-1.25 HEX LOCKNUT
2B-6808-00
QTY. 4

TOOLS NEEDED

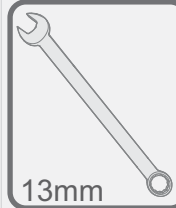

13mm

13mm

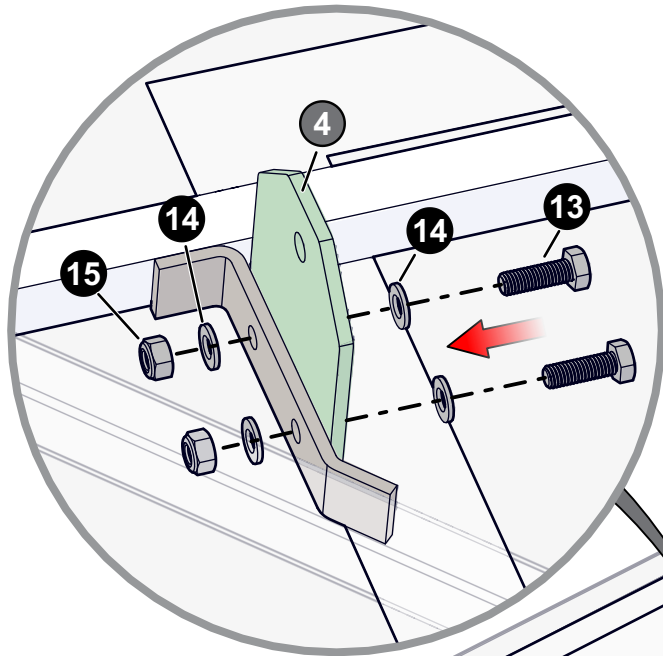

NOTE

MAKE SURE HEAD OF BOLTS ARE ASSEMBLED ON THE INSIDE OF THE BRACKET AS SHOWN IN THE DETAIL VIEWS. FULLY TIGHTEN THIS HARDWARE UNTIL SECURE.

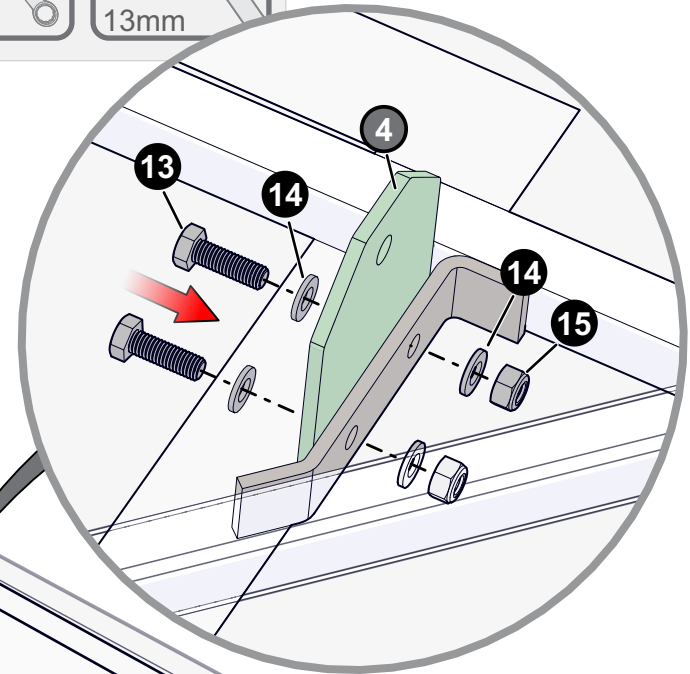

IMPORTANT NOTE

ASSEMBLE PARTS EXACTLY AS SHOWN IN ASSEMBLY DIAGRAM.

NOTE ORIENTATION OF MOUNTING CONNECTOR PLATES ITEM #4

THE FOLLOWING STEPS REQUIRE 2 PEOPLE.

NOTE

ATTACH BACKBOARD TO THE TOP BRACKETS AND THEN SWING BACKBOARD DOWN ONTO THREADED STUDS EXTENDING FROM BACKBOARD MOUNTING CHANNEL (#3).

NOTE

AFTER BACKBOARD ASSEMBLY IS MOUNTED TO WALL BRACKET (#1) FULLY TIGHTEN HARDWARE ON CONNECTOR PLATES (#4). THEN, FULLY TIGHTEN HARDWARE ON MOUNTING CHANNEL (#3) THAT WAS ASSEMBLED ON PAGE 8.

! WARNING

USE EXTREME CAUTION WHEN STANDING ON LADDERS TO PERFORM ASSEMBLY STEPS. FOLLOW ALL WARNINGS AND CAUTIONS ON THE LADDER. FAILURE TO FOLLOW ALL THESE INSTRUCTIONS AND WARNINGS COULD LEAD TO SERIOUS PERSONAL INJURY OR PROPERTY DAMAGE.

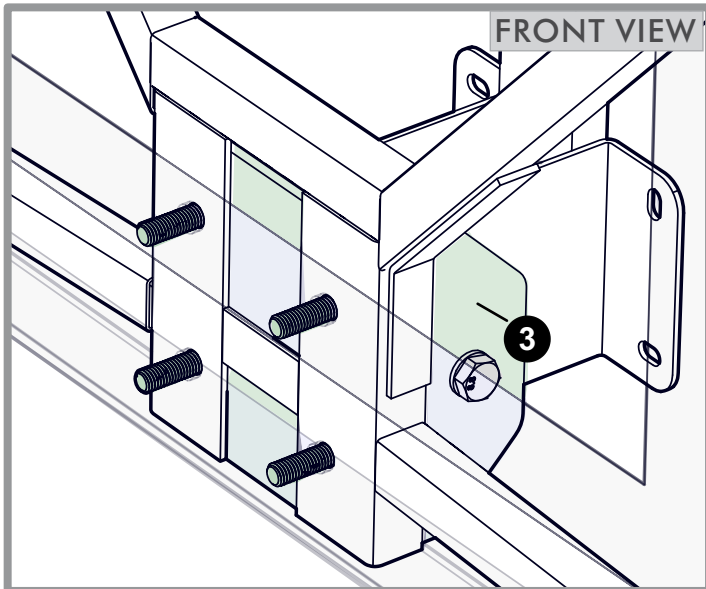

HARDWARE NEEDED (ACTUAL SIZE)

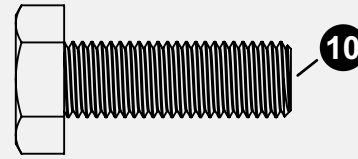

HEX HEAD BOLT M10-1.25 X 30mm
1B-7239-00
QTY. 2

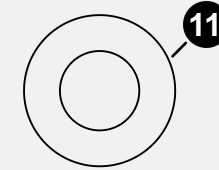

WASHER M10
2B-6800-00
QTY. 4

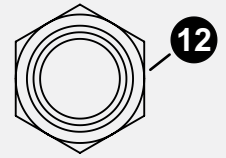

M10-1.5 HEX LOCK NUT
2B-6801-00
QTY. 4

TOOLS NEEDED

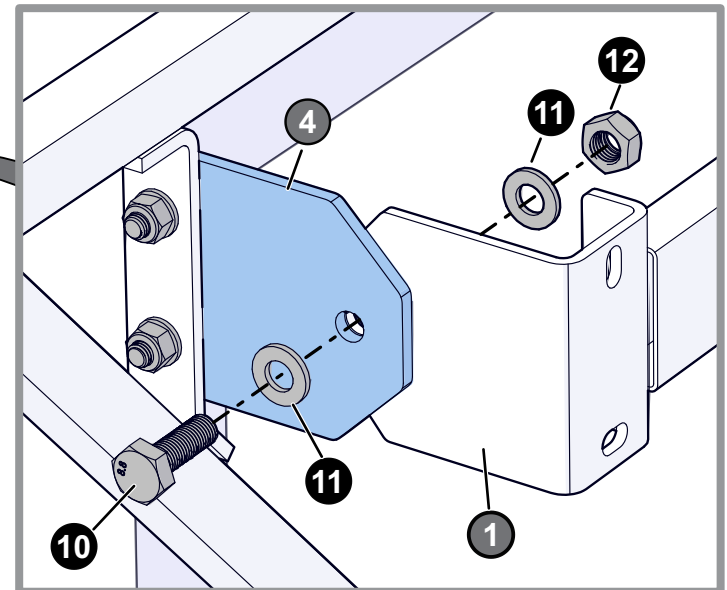
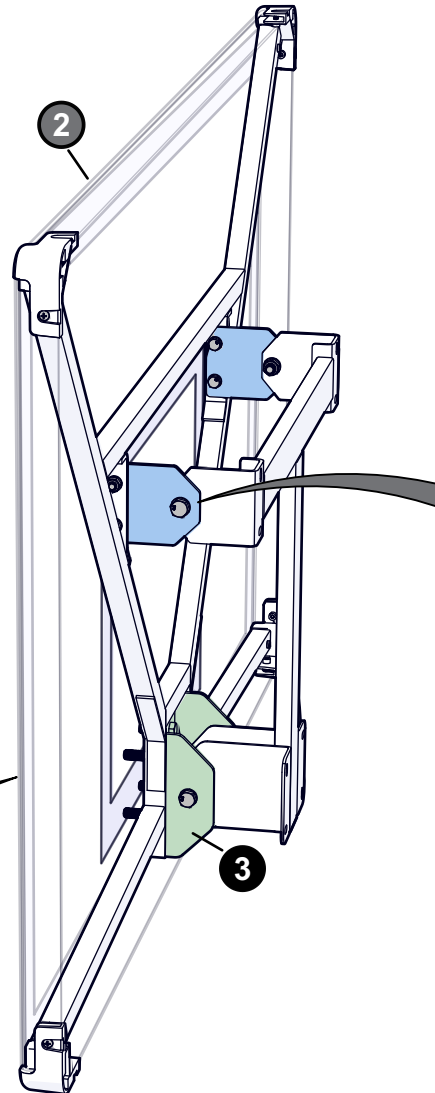
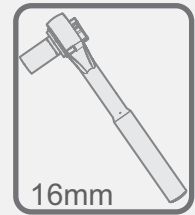
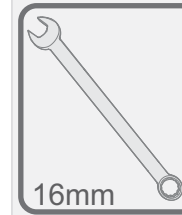

TOOLS NEEDED

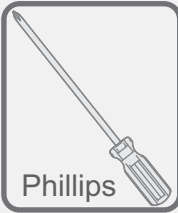

Phillips

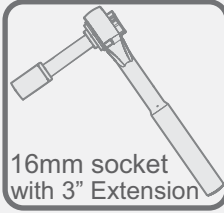

16mm socket with 3" Extension

NOTE

TAKE PROTECTIVE COATING OFF THE BACKBOARD BEFORE ATTACHING THE RIM. LEVEL RIM AND FULLY TIGHTEN THE HARDWARE.

CAUTION

NEVER USE RIM WITH COVERPLATE REMOVED!

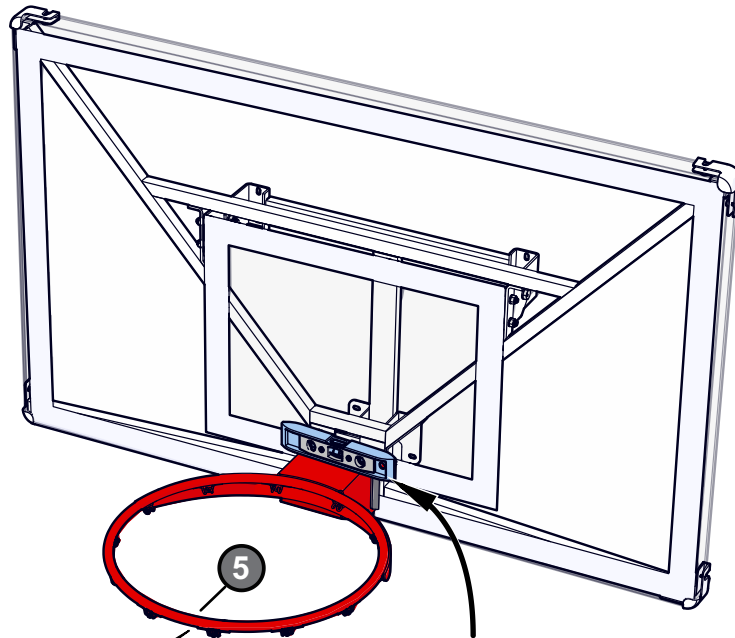

NOTE

LEVEL RIM BEFORE TIGHTENING.

HARDWARE NEEDED (ACTUAL SIZE)

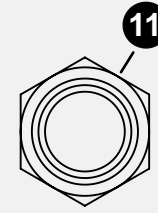

M10-1.5 HEX LOCK NUT
2B-6801-00
QTY. 4

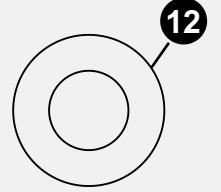

WASHER M10
2B-6800-00
QTY. 4

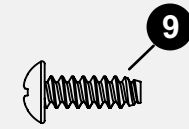

#8 X 1/2" THREAD CUTTING SCREW
1B-6238-01
QTY. 4

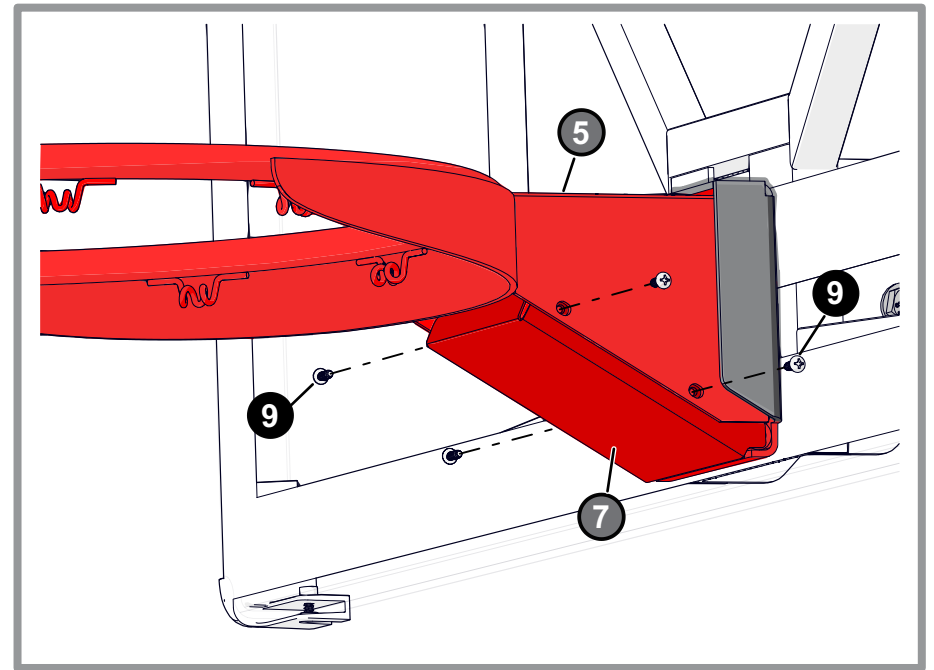
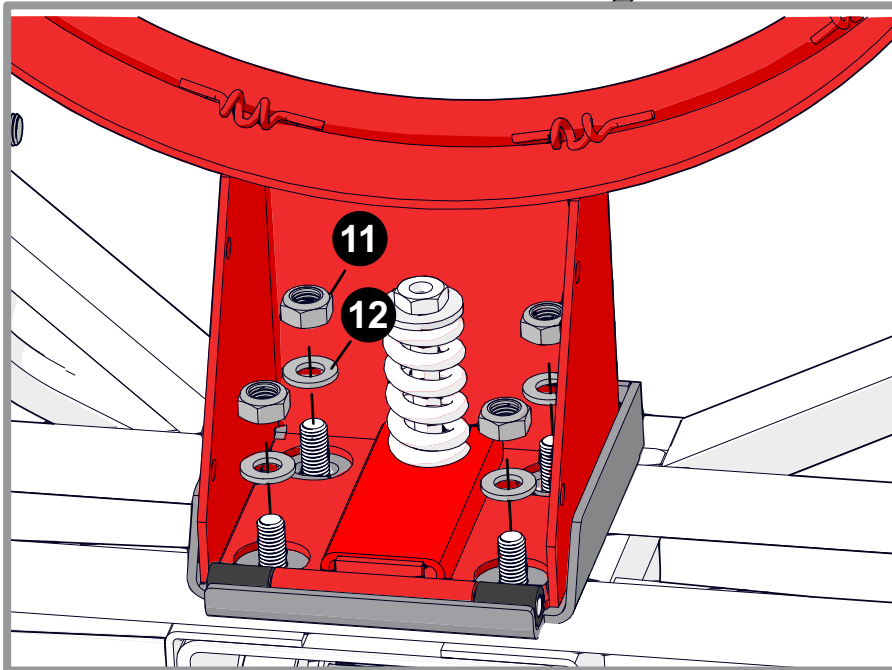

DETAIL A

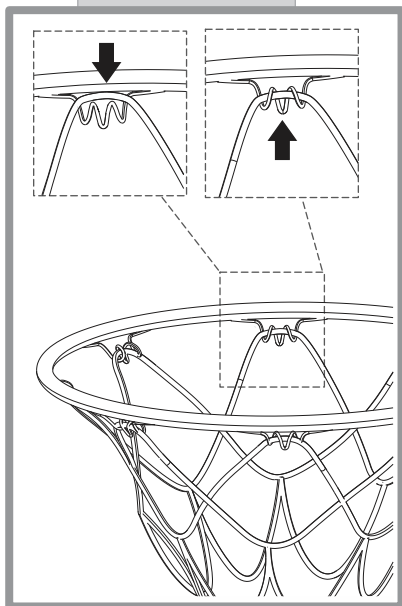

CARE INFORMATION

BACKBOARD CARE AND MAINTENANCE

Items needed to clean backboard:

- 100% cotton soft cloth, (only)
- Mild dish washing liquid for soap
- Luke warm water
- Mild plastic polish to minimize scratches

Rinse backboard with lukewarm water. Wash gently with a **100% Cotton** soft cloth, lukewarm water and **mild** soap. Do not scrub. Rinse backboard with lukewarm water again. Dry with **100% Cotton** soft cloth. To minimize scratches and minor abrasions to your backboard, apply a **mild** polish such as Johnson's Paste Wax, Novus Plastic Polish # 1 or Mirror Glaze Plastic Polish. Strong cleansers will damage backboard and void warranty.

RIM

Do not dunk or hang from the rim or any part of this system. Rims are not warranted for any defects other than workmanship. Torn back plates, damaged springs, bent rings, damaged eye bolts, and torn or distorted rim supports result from hanging on the rim and are not warranted.

Wear a mouth guard when playing to avoid dental injuries

RUST

Inspect your wall hanging system periodically, if rust should appear, remove loose paint, sand lightly, primer and paint with exterior flat matte finish enamel paint.

LIMITED 5 YEAR WARRANTY

This consumer warranty extends to the original consumer purchase of any Escalade® Sports Product (hereinafter referred to as the "Product").

WARRANTY COVERAGE: Escalade® Sports warrants to the original Consumer Purchaser that any Product of its manufacture is free from defects in material and workmanship. THIS WARRANTY IS VOID IF THE PRODUCT HAS BEEN DAMAGED BY ACCIDENT, UNREASONABLE USE, NEGLIGENCE, IMPROPER SERVICE, FAILURE TO FOLLOW INSTRUCTIONS PROVIDED WITH THE PRODUCT OR OTHER CAUSES NOT ARISING OUT OF DEFECTS IN MATERIAL OR WORKMANSHIP.

Subject to proper installation and normal Residential use, Escalade® Sports warrants, subject to the limitations below, to the original retail purchaser all structural components of the Silverback® System to be free of defects in material and workmanship for a period of five (5) years from the original purchase.

Merchandise must be shipped prepaid with a copy of proof of purchase to Escalade® Sports factory for examination to determine if the basketball system needs to be repaired or replaced. Any labor costs, travel expenses and any other changes involved in the removal, installation or replacement of the defective/repared parts from/to your Silverback® System will be the purchaser's responsibility. Shipping charges for replaced or warranted merchandise sent back to the customer from Escalade® Sports factory must be prepaid by the customer in advance. If not, the replacement shipment will be sent out collect.

Escalade® Sports reserves the right to examine photographs or physical evidence of merchandise claimed to be defective, and to recover said merchandise, prior to authorization of warranty claims. A "Returned Goods Authorization" number may be required, please call for details prior to the return of any photographs or merchandise.

This limited 5 year warranty is expressly in lieu of all warranties, expressed or implied, including warranties of merchantability or fitness for use. Escalade® Sports does not assume or authorize any person or representative to assume for us, any other liability in connection with the sale of our products.

The remedy of repair or replacement stated above is Escalade® Sports exclusive remedy. Escalade® Sports will not be liable for any other damages or expenses which may incur, including but not limited to incidental or consequential damages. Escalade® Sports assumes no other obligations or liability on the part of the purchaser, and Escalade® Sports neither assumes nor authorizes any other person to assume for it any other liability in connection with the goods sold.

This warranty shall not apply in any manner to parts or accessories not manufactured by Escalade® Sports.

NOT COVERED BY THIS WARRANTY

- Merchandise not intended to be in places of public assembly, such as, but not limited to, schools, parks, public or private recreational facilities.
- Any merchandise subjected to Non-residential abuse, negligence, improper installation, vandalism, acts of God, alteration of product, or any other events beyond the control of Escalade® Sports.
- Paint or rusted parts. If rust should appear, remove loose paint, sand lightly, primer and paint with exterior flat matte finish enamel paint.
- HANGING ON RIM WILL VOID THE WARRANTY: Rims are not warranted for any defects other than workmanship. Torn back plates, damaged springs, bent rings, damaged eyebolts, and torn or distorted rim supports result from hanging on the rim and are not warranted.
- Shipping charges both ways. Note: Any merchandise shipped to Escalade® Sports collect will be refused.
- Dealer service charges, labor charges and travel expenses associated with replacement of repair of warranty item.

WARRANTY DISCLAIMERS: ANY IMPLIED WARRANTIES ARISING OUT OF THIS SALE, INCLUDING BUT NOT LIMITED TO THE IMPLIED WARRANTIES OF MERCHANTABILITY AND FITNESS FOR A PARTICULAR PURPOSE, ARE LIMITED IN DURATION. ESCALADE® SPORTS SHALL NOT BE LIABLE FOR LOSS OF USE OF THE PRODUCT OR OTHER CONSEQUENTIAL OR INCIDENTAL COSTS. EXPENSES OR DAMAGES INCURRED BY THE CONSUMER OF ANY OTHER USE.

Some states do not allow the exclusion or limitation of implied warranties or consequential or incidental damages, so the above limitations or exclusions may not apply to you.

LEGAL REMEDIES: This warranty gives you specific legal rights, and you may also have other rights which may vary from state to state.

WARRANTY GUIDELINES IS REQUIRED FOR ALL WARRANTY CLAIMS

1. Proof of Purchase (original retail purchaser) is required for all warranty claims.
 2. Call or write Escalade® Sports to receive a Return Authorization # and determine specific needs.
- Phone: 1-888-USA-GOAL / Warranty Dept.
Or Write Escalade® Sports at: Escalade® Sports - P.O. Box 889, Evansville, IN 47706 - Attn: Warranty Dept.
Or E-mail us at: basketball@escaladesports.com