



USER MANUAL

830W Full Range 5-Channel Class D Amplifier | BE830.5D

**Thank you for purchasing this BOSS Elite amplifier!**

For the best performance and product experience, please read this user manual thoroughly.

If there are any technical questions, please contact:

Customer care: 805-751-4853 & Live chat

Online support: [www.bosssaudio.com/support](http://www.bosssaudio.com/support)

**Table of Contents**

Package Contents.....2

Introduction .....2

Important .....3

Control Panel.....4

Connector Panel .....6

Amplifier Setup Procedure.....6

Protection Mode .....7

Mounting.....8

Wiring .....8

    Low-Level Input Wiring .....8

    High-Level Input Wiring ..... 10

    Speaker Wiring ..... 11

    Remote Subwoofer Control Connection ..... 12

    Power Connection ..... 13

Troubleshooting ..... 14

Specifications..... 15

## Package Contents

When first unpacking your new amplifier, please verify the package contains all of the items listed below. If any items are identified as missing, please contact the place of purchase.

- 1x Amplifier
- 3x RCA input wiring harnesses
- 3x Speaker output wiring harnesses
- 1x Remote subwoofer control and connection cable
- 4x Screws (M4 x 25mm) and rubber washers for amplifier mounting
- 2x Screws (M3 x 10mm) for subwoofer control mounting
- 1x Plug-in power connector
- 1x AGU fuse holder with 80A fuse
- User manual and warranty card

## Introduction

This product is designed as a car audio amplifier. The included input wiring harnesses can be used for low level or high level input (via cutting off the RCA female connectors). A flexible system of controls is equipped for you to integrate the amplifier into your audio system.

The amplifier features the following:

- Full-range Class D amplifier
- 5-channel output. CH 1-2 & CH 3-4 bridgeable
- 2 $\Omega$  stereo stable
- MOSFET PWM (Pulse Width Modulated) power supply
- RCA low level input
- High level input
- Variable input gain control
- Variable low pass filters (for CH 1-5)
- Variable high pass filters (for CH 1-4)
- Variable bass boost (for CH 5)
- Input sensitivity selector (Input voltage selection)
- Thermal, short and overload protection
- Remote subwoofer control
- LED illuminated end panels

## Important

Please read and understand all instructions before you use your product. Failure to follow the instructions could result in injury and/or damage that could potentially void the warranty.

### Important Safety Precautions

- Do not open or attempt to repair this product yourself. Dangerous high voltages are present which may result in electric shock.
- To avoid risk of electronic shock or damage to the product, do not permit the product to become damp or wet from water or drinks. If this does occur, immediately unplug the power wires and send the product to your local dealer or service center as soon as possible.
- Do not make any adjustment on the product when driving or in other situations where distractions can be hazardous. Responsible and safe driving is your primary responsibility when operating a vehicle.
- In the event of smoke, strange noise or odor emitted from the product or any other abnormal operational signs appearing on the product, disconnect the product from the power supply. Discontinue use and contact your dealer or our technical support team. Using the product in this condition may result in permanent damage to the system.
- Servicing must only be carried out by an authorized technician. Contact our technical support for any service questions.

### Installation Precautions

- **WARNING: Always consult a professional installer.**
- Installation must be performed by a professional. Contact our technical support for any installation questions.
- Before installing any electrical accessories to your vehicle, always make sure the vehicle's electrical system is equipped to handle the extra electrical load.
- Before installation, disconnect the negative terminal of the vehicle battery to prevent damage to the product, fire, and/or possible injury.
- Always connect the power cable to the positive battery terminal through an appropriate fuse. This can avoid a short circuit.
- Use only installation parts provided with the product. Using other mounting methods may void the warranty.
- Prior to any use, the amplifier must be fully mounted and secured and installed into the vehicle. All wiring should be secured and properly insulated. Failure to do so can result in damage.
- Observe the safety and operating instructions of the devices which are connected to this product.
- **Do not** use any aggressive cleaning agents. Clean the product with a dry, fiber-free cloth.

### Care of the Environment

Please familiarize yourself about the local separate collection system for electrical and electronic products. Do not throw away the product with the normal household waste at the end of its life, instead take it to a recycling center. By doing so, you help to preserve the environment.

# Control Panel

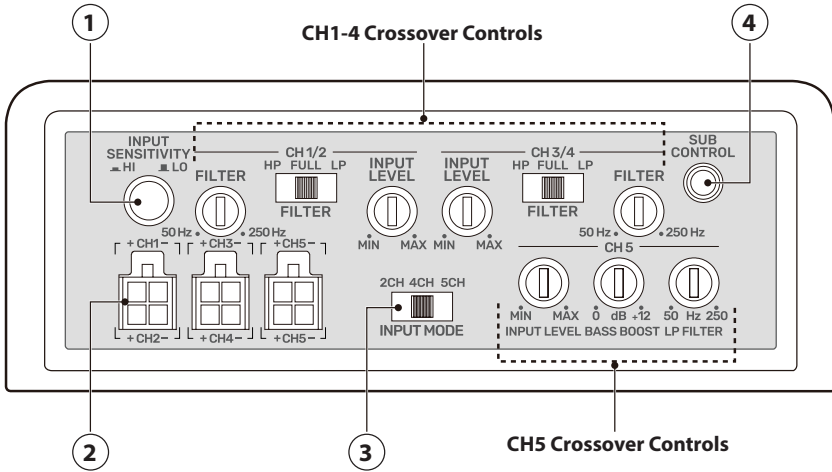

## General Controls

### 1 INPUT SENSITIVITY Selector

Set to **LO** (400mV - 4V input) when connecting low-level input (RCA input) from your source unit.

Set to **HI** (4V - 40V input) when connecting high-level input (speaker level input) from your source unit.

### 2 Audio Input Connectors (CH1- 5)

Connect to the supplied RCA input wiring harnesses.

### 3 INPUT MODE Selector

Set the Input Mode Selector relative to the available outputs from your source unit.

**2H** when connecting the front 2-channel (left & right) outputs from your source unit.

**4H** when connecting the front/rear 4-channel outputs from your source unit.

**5H** when connecting the front/rear/sub channel outputs from your source unit.

### 4 SUB CONTROL Port

Connect to the supplied remote subwoofer volume control. Use the control to adjust volume level of the subwoofer (CH5).

## CH1-4 Crossover Controls (Front & Rear Speakers)

### INPUT LEVEL Control

Adjust the input level to the CH1/2 or CH3/4 speakers so as to match the output level from your source unit.

**Important!** Do not adjust the input level to maximum unless your input level requires it. Set the input gain just below the level of distortion.

### **FILTER Mode Selector (HP/FULL/LP)**

- When setting to **HP**, the High Pass Filter will be enabled for the CH1/2 or CH3/4 speakers.
- When setting to **FULL**, the CH1/2 or CH3/4 speakers will receive low, mid and high frequencies to reproduce sound.
- When setting to **LP**, the Low Pass Filter will be enabled for the CH1/2 or CH3/4 speakers.

### **FILTER Frequency Control (50–250 Hz)**

Use this control to set the frequency range you want the CH1/2 or CH3/4 speakers to receive.

- Set the FILTER Mode selector to the **HP** position to enable the High Pass Filter, and the CH1/2 or CH3/4 will only receive the frequencies above the one you set to reproduce sound.
- Set the FILTER Mode selector to the **LP** position to enable the Low Pass Filter, and the CH1/2 or CH3/4 will only receive the frequencies below the one you set to reproduce sound.
- When the FILTER Mode selector is set to the **FULL** position, the FILTER Frequency Control is not adjustable and full-range frequencies are applied.

### **CH5 Crossover Controls (Subwoofer)**

#### **INPUT LEVEL Control**

Adjust the input level to the CH5 speaker so as to match the output level from your source unit.

**Important!** Do not adjust the input level to maximum unless your input level requires it. Set the input gain just below the level of distortion.

#### **BASS BOOST Control**

Use this control to increase sound output level of bass frequencies for the CH5 speaker.

#### **LP FILTER Frequency Control (50–250 Hz)**

Use this control to set the frequency range you want the CH5 speaker to receive. The CH5 speaker will only receive the frequencies below the one you set to reproduce sound.

## Connector Panel

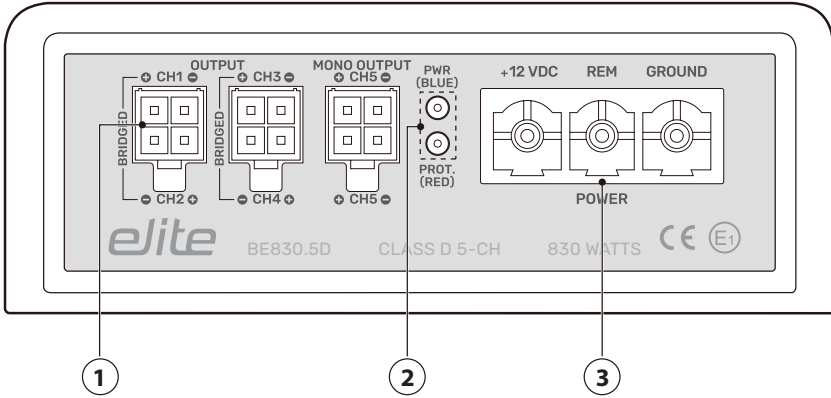

### 1 Speaker Output Connectors

Connect to the supplied speaker output wiring harnesses.

### 2 Status Indicators

**PWR LED (Blue):** Lights up to indicate the amplifier is powered on and operational.

**PROT. LED (Red):** Lights up to indicate the amplifier is in protection mode and not operational. This problem can be caused by input overload, short circuit or high temperature.

### 3 POWER Terminals

Connect directly to the supplied plug-in power connector.

**+12 VDC:** For connection to the positive terminal of the 12V vehicle battery.

**REM:** For connection to the remote output wire of your head unit. No need to make the remote connection if you use high-level input connection and auto power on function is activated.

**GROUND:** For connection to the closest point on the chassis of your vehicle.

## Amplifier Setup Procedure

1. Secure the amplifier in a suitable location in the vehicle. See the section "Mounting" on page 8.
2. Disconnect the negative terminal on the vehicle battery to prevent a short circuit.
3. Connect audio inputs. See the section "Low Level Input Wiring" on page 9, or "High Level Input Wiring" on page 10.
4. Connect audio outputs. See the section "Speaker Wiring" on page 11.
5. Connect to power supply. See the section "Power Connection" on page 13.
6. Recheck all wirings to ensure correct and secure power/input/output connections.
7. Set all input gain controls (**INPUT LEVEL**) to the minimum position, and set all filter controls to the desired frequency points.

8. Reconnect the negative battery terminal.
9. Turn on the source unit, then the amplifier automatically turns on.
10. Set your source unit to about 3/4 volume, then turn up the amplifier's input gain controls (**INPUT LEVEL**) to just below the level of distortion.
11. If necessary, further fine tune the various controls to obtain best results.

## Important notes on input gain control

- The input gain control (**INPUT LEVEL**) is designed only to adjust the input level to the amplifier so as to match the output level from your source unit. It is not a volume control!
- Never adjust the input level to maximum unless your input level requires it.
- Failure to notice these instructions will result in an input overload to the amplifier and excessive audio distortion. It can also trigger protection mode, or may cause damage to the amplifier or your speakers.

## Protection Mode

When protection mode triggers, the **PROT.** LED (Red) on the amplifier turns on and the amplifier shuts down.

One of the following reasons can trigger protection mode: input overload, short circuit or high temperature.

When the **PROT.** LED (Red) turns on, take the following measures.

- Check the system carefully to determine what has caused the protection mode to trigger.
- Reset the amplifier. Turn off the amplifier (by turning off the head unit or other audio source which feeds the amplifier) and turn it on again.
- If the shut down was due to either an input overload or a short circuit, correct the conditions which cause the overload or short circuit then turn on the amplifier again.

## Mounting



See the section “Installation Precautions” on page 3.

Before you drill or cut any holes, investigate your car’s layout very carefully. Take special care when you work near the gas tank, fuel lines, hydraulic lines and electrical wiring.

Mount the amplifier in the location away from moisture, and where connection cables are not pinched or damaged by sharp objects.

- 1 Find a suitable location in the vehicle to mount the amplifier. Make sure there is sufficient air circulation around the intended mounting location.
- 2 Secure the amplifier with the four supplied screws (M4 x 25mm):

- a. Use the four screw holes on the amplifier to mark the mounting holes on the mounting surface.
- b. Drill the mounting holes in the mounting surface.
- c. Place the amplifier in position, and fix the amplifier on the mounting surface using the four supplied screws and rubber washers.

Remember to attach the rubber washers for secure fastening.

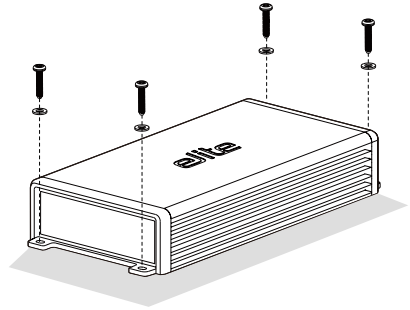

## Wiring



See the section “Installation Precautions” on page 3.

For safety, disconnect the negative terminal of the vehicle battery prior to wiring.

Use only high quality cables for reliable installation to minimize signal or power loss.

Make sure cables are not squeezed or damaged by sharp edges. Use rubber bushings for penetrations.

Make sure all the cables are securely connected and bare wires are properly insulated.

Reconnect the negative battery terminal only when all cable connections are correctly and securely made.

## Low-Level Input Wiring

The amplifier offers you two wiring alternatives for audio input from your head unit. Low-level input wiring is preferred for best audio performance. It provides an exceptional clean sound from the head unit.

**Important!** Do not connect both the high-level and low-level inputs from your head unit to the amplifier at the same time.

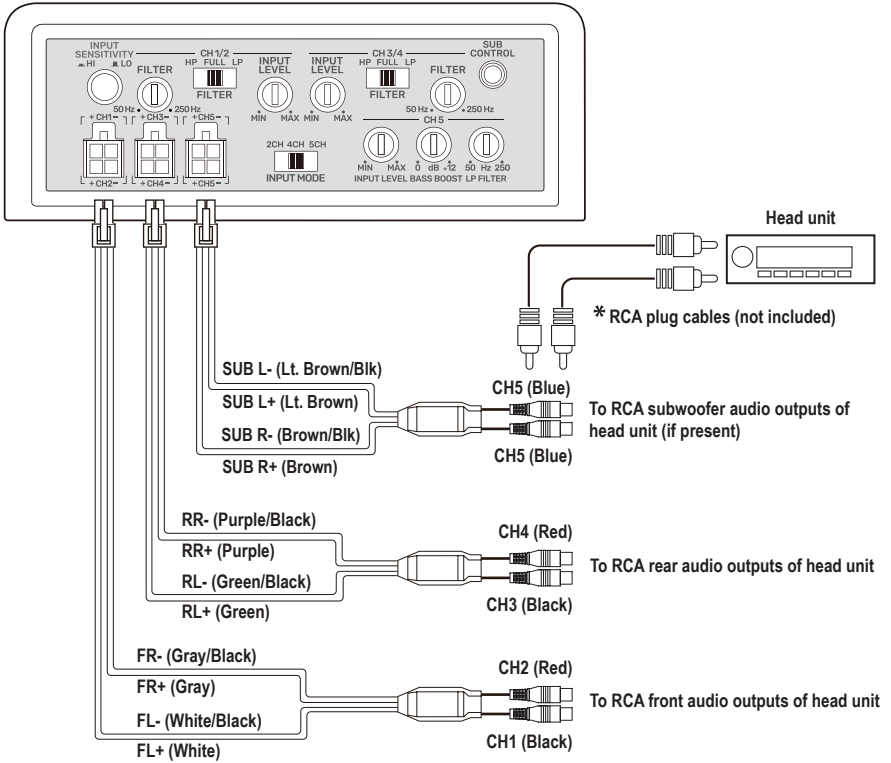

\* Using RCA plug cables (not included), connect RCA female connectors on the amplifier to the RCA audio outputs on your head unit. Make sure the left and right channels are correctly matched. To reduce the possibility of noise entering signal chain, use high-quality RCA cables for better insulation and run the RCA cables away from large wire loops, electric fan and power wires.

## 5-Channel Input

- Make CH1, CH2, CH3, CH4 and CH5 input connections illustrated above.
- Set **INPUT SENSITIVITY** to the **LO** position, and set **INPUT MODE** to the **5CH** position.

## 4-Channel Input

- Make CH1, CH2, CH3 and CH4 input connections illustrated above.
- Set **INPUT SENSITIVITY** to the **LO** position, and set **INPUT MODE** to the **4CH** position.

## 2-Channel Input

- Make CH1 and CH2 input connections illustrated above.
- Set **INPUT SENSITIVITY** to the **LO** position, and set **INPUT MODE** to the **2CH** position.

# High-Level Input Wiring

The amplifier offers you two wiring alternatives for audio input from your head unit. Use high-level input wiring for audio input only when your head unit does not have the RCA audio outputs for connection.

**Important!** Do not connect both the high-level and low-level inputs from your head unit to the amplifier at the same time.

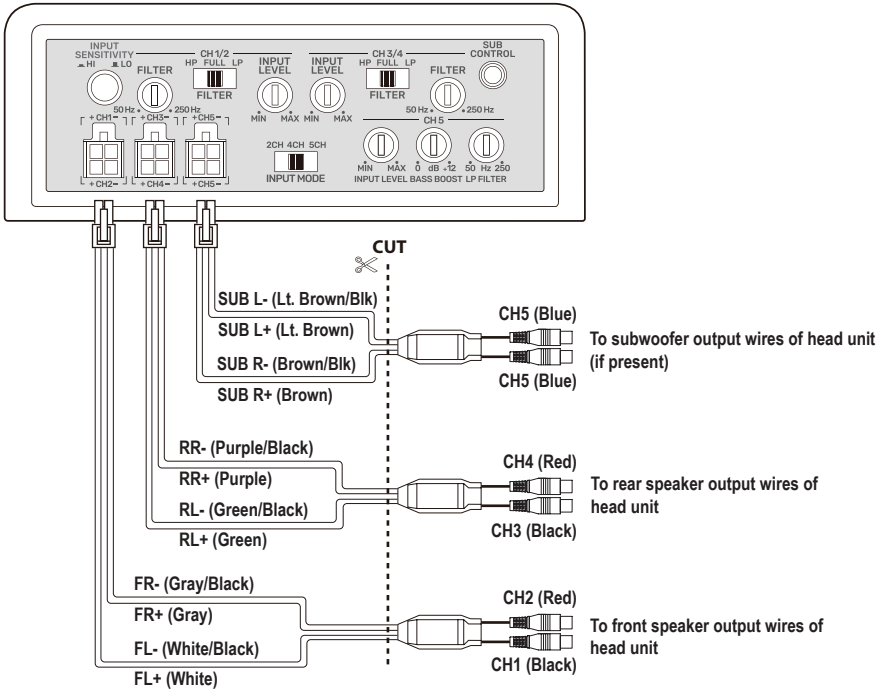

As illustrated above, cut off the RCA female connectors so that the supplied input harness can be used for high-level input. Then connect the colored wires to speaker output wires of your head unit. Observe speaker polarity. Make sure the speaker wires are securely connected and properly insulated.

## 5-Channel Input

- Make CH1, CH2, CH3, CH4 and CH5 input connections illustrated above.
- Set **INPUT SENSITIVITY** to the **HI** position, and set **INPUT MODE** to the **5CH** position.

## 4-Channel Input

- Make CH1, CH2, CH3 and CH4 input connections illustrated above.
- Set **INPUT SENSITIVITY** to the **HI** position, and set **INPUT MODE** to the **4CH** position.

## 2-Channel Input

- Make CH1 and CH2 input connections illustrated above.
- Set **INPUT SENSITIVITY** to the **HI** position, and set **INPUT MODE** to the **2CH** position.

# Speaker Wiring

**Important!** Do not connect speakers with an impedance lower than the one specified in the illustration below.

Observe speaker polarity. Make sure the speaker wires are securely and properly insulated.

## Five Channel Mode

You can use the amplifier to run four speakers and a separate subwoofer.

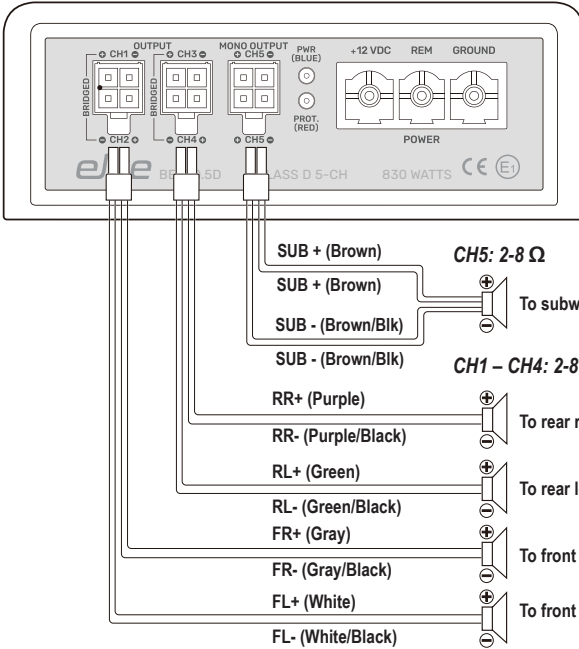

### Important!

**CH5** is a higher powered channel. Always combine two "SUB +" together, and two "SUB -" together. Doing so can prevent overheating the wires.

## Bridged Mode

You can bridge two channels (CH1 & CH2, and CH3 & CH4) to run a speaker for more power output.

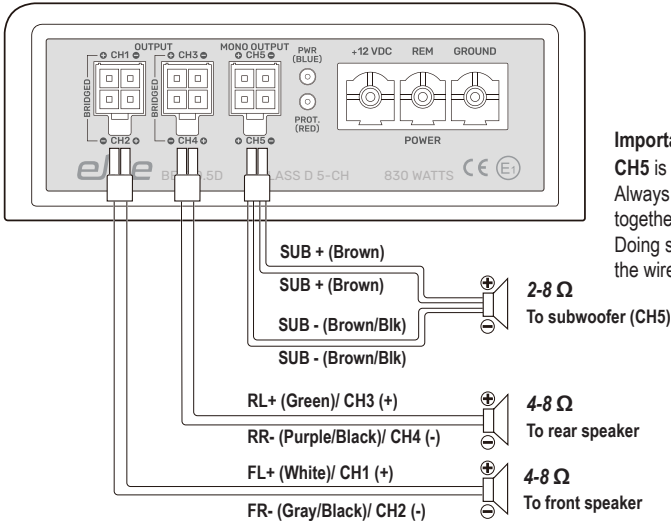

### Important!

**CH5** is a higher powered channel. Always combine two "SUB +" together, and two "SUB -" together. Doing so can prevent overheating the wires.

## Remote Subwoofer Control Connection

Use the supplied remote subwoofer control to independently adjust the volume level output of the subwoofer.

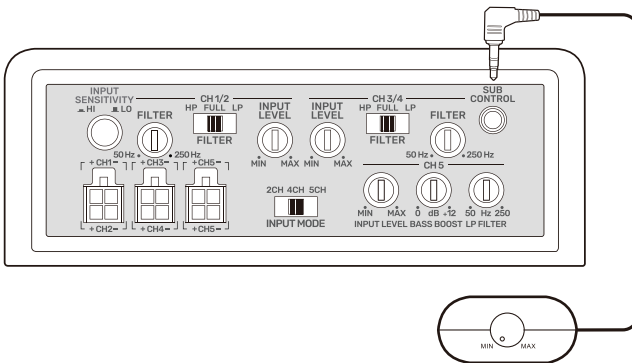

Remote subwoofer control

- Using the supplied remote subwoofer control cable, connect the remote subwoofer control to the **SUB CONTROL** on the subwoofer.
- We recommend to position the remote subwoofer control under the dash or in a similar location where using it will not distract the driver. Fasten the remote subwoofer control using the two supplied screws (M3 x 10mm).

# Power Connection

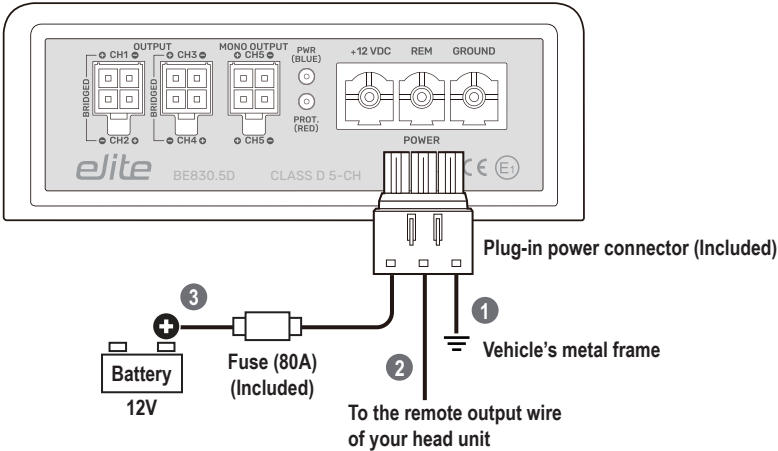

- 1** Using an 8 gauge (or heavier) wire, connect the **Ground terminal** on the supplied power connector plug to the closest point on the metal frame of your vehicle. Keep the ground wire as short as possible.  
Scrape away any paint, rust or dirt from the ground point to provide a clean contact. Fasten the ground cable on the ground point with a screw or bolt.
- 2** Using a 16 gauge (or heavier) wire, connect the **Remote terminal** on the supplied power connector plug to the remote output wire of your head unit.  
The remote connection is used for power control. The amplifier automatically turns on or off every time the head unit is turned on or off.  
If your head unit does not have the remote turn-on wire, connect the remote wire on the amplifier to the ignition switch wire of your vehicle. In this case, make sure your head unit is also turned on or off with the operation of the ignition switch to avoid noise occurrence.
- 3** Using an 8 gauge (or heavier) wire, connect the **+12V terminal** on the supplied power connector plug to the positive terminal of the 12V vehicle battery through the supplied fuse (80A). Keep the fuse within 18" (45 cm) of the vehicle battery.  
It is important to connect the power supply through a fuse. This can avoid a short circuit.
- 4** Plug the power connector into the **POWER** terminals on the amplifier to complete wiring.

## Troubleshooting

If you have problems using this product, check the following points before you request service. If you still have a problem, contact our technical support.

Problem	Solution
No power.	Check that the amplifier is properly grounded (e.g. clean contact point on the chassis and secure ground connection).
	Check that there is at least 9V DC remote input on the <b>REM</b> terminal
	Check that there is battery power or at least 12V input on the <b>+12V</b> terminal.
	Check all fuses. Replace faulty one with the same type and rating.
<b>PROT.</b> LED (Red) lights up.	Turn down volume on your source unit to prevent overdriving.
	Reset the amplifier by turning it off and on again. See the section "Protection Mode" on page 7 for more details.
	Check that speaker impedance matches the specified.
	Check for damaged or shorted speaker or speaker wire.
No sound.	<p>Check that audio input connection is correctly and securely made.</p> <p>If using low-level input connection, check the RCA cables are correctly and securely plugged.</p> <p>If using high-level input connection, check connection with the speaker wires of your source unit.</p>
Low output.	Adjust the remote subwoofer level control to increase sound level.
	Input gain level is too low. Reset the input level control.
	Check the frequency pass filter settings.
Distorted sound.	Check that the input gain control is set to match the output level from your source unit. Always try to set the input gain level as low as possible.
	Check that the frequency pass filter is set correctly.
	Check for short circuits on the speaker wires, or the broken wires.
Hissing sound.	Try to set the source unit volume as high as possible (without distortion) and set the input gain level on the amplifier as low as possible.
Engine noise (static type).	This is usually caused by poor quality RCA cables, which can pick up radiated noise. Use only the high quality RCA cables and route them away from the power cables, large wire loops and electric fan.
Engine noise (alternator whine).	Check that the speaker wires are not shorted to the vehicle chassis.
	Check that your source unit is properly grounded.
Amplifier gets very hot.	Check the minimum speaker impedance for the amplifier is correct.
	Check that there is good air circulation around the amplifier. In some applications, it may be necessary to add an external cooling fan.

# Specifications

## Audio

RMS output power .....	Total 830W
CH1 – CH4 (front/rear speakers) .....	95W x 4 @ 2Ω
	60W x 4 @ 4Ω
	190W x 2 @ 4Ω bridged
CH5 (subwoofer) .....	450W @2Ω
	250W @4Ω
Min. speaker impedance .....	2Ω stereo, or 4Ω bridged
Total harmonic distortion (THD) .....	<0.2%
Frequency response .....	10Hz – 20kHz
Signal-to-noise ratio .....	>90dB
Channel separation .....	>50dB
Input sensitivity .....	400mV - 4V (Low level/RCA)
	4V - 40V (High level)
Low pass filter (LPF) .....	50Hz – 250Hz
High pass filter (HPF) .....	50Hz – 250Hz
Bass boost .....	0 to +12dB

## General

Power supply .....	12V DC
Current consumption .....	max. 80A
Fuse .....	AGU type, 80A
PWM MOSFET power supply .....	yes
Protection circuitry .....	yes (overload, short circuit, and thermal protection)
Remote turn-on/turn-off .....	yes
Input gain control .....	yes, variable
LED indicators .....	blue - power on; red - protection
Weight .....	3.46 lbs (1.57 kg)
Dimensions .....	11.33" x 4.56" x 1.71" (288 x 116 x 43.5mm)

*Specifications are subject to change without notice.*



BOSS Audio Systems Elite  
1451 Vanguard Drive, Oxnard, CA 93033  
[www.bosselite.com](http://www.bosselite.com)  
**805-751-4853 Customer Service**  
**Tech Support: [www.bossaudio.com/support](http://www.bossaudio.com/support)**



V:1K  
1225