

User manual

Microwave

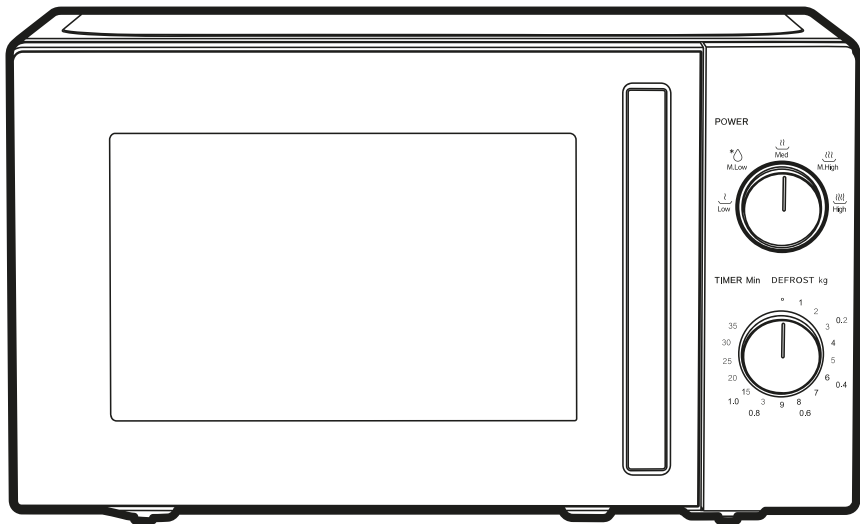

To register for your extended guarantee, scan the QR code or visit guarantee.uppic.com/salter and register your product within 30 days of purchase. For any further queries, visit www.salter.com.

Description of parts

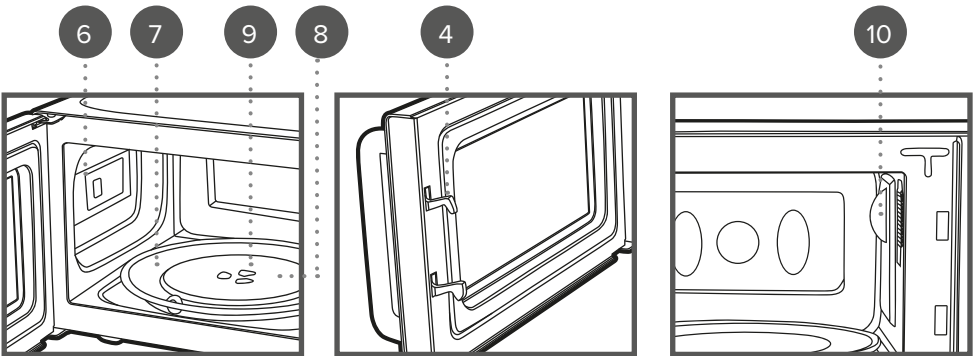
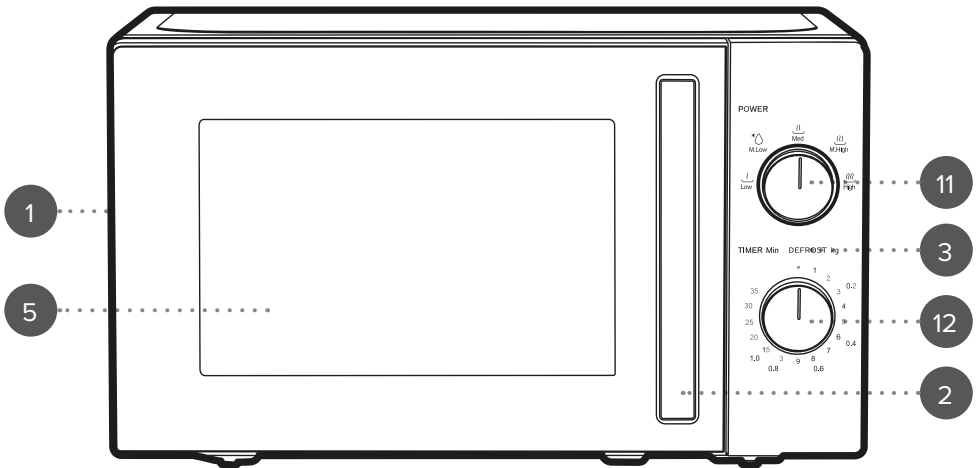

- 1. Microwave main unit
- 2. Door handle
- 3. Control panel
- 4. Door safety interlock
- 5. Viewing window
- 6. Oven cavity

- 7. Glass turntable
- 8. Turntable ring
- 9. Turntable shaft
- 10. Waveguide cover
- 11. Power dial
- 12. Time dial

Please retain instructions for future reference.



WARNING – READ BEFORE USE If the door or door seals are damaged, the appliance must not be operated until it has been repaired by a competent person. It is hazardous for anyone other than a competent person to carry out any service or repair operation that involves the removal of a cover which gives protection against exposure to microwave energy. Liquids and other foods must not be heated in sealed containers since they are liable to explode. The heating of beverages in the appliance can result in delayed eruptive boiling, therefore extreme care must be taken when handling the container. Always allow beverages to stand for at least 20 seconds before handling. If necessary, stir during heating. Always stir after heating.

SAFETY INSTRUCTIONS

- When using electrical appliances, basic safety precautions should always be followed.
- Check that the voltage indicated on the rating plate corresponds with that of the local network before connecting the appliance to the mains power supply.
- This appliance can be used by children aged from 8 years and above and persons with reduced physical, sensory or mental capabilities and knowledge, if they have been supervised/instructed and understand the hazards involved.
- Children shall not play with the appliance.
- Children should not perform cleaning or user maintenance, unless they are older than 8 and supervised.
- This appliance is not a toy.
- If the power supply cord, plug or any part of the appliance is malfunctioning or if it has been dropped or damaged, cease using the product immediately to avoid potential injury.
- This appliance contains no user serviceable parts, only a qualified electrician should carry out repairs. Improper repairs may place the user at risk of harm.
- Keep the appliance and its power supply cord out of the reach of children.
- Keep the appliance out of the reach of children when it is switched on or cooling down.
- Keep the appliance and its power supply cord away from heat or sharp edges that could cause damage.
- Keep the power supply cord away from any parts of the appliance that may become hot during use.
- Keep the appliance away from other heat emitting appliances.
- Do not allow the power supply cord to hang over worktops, touch hot surfaces or become twisted.
- Do not immerse the electrical components of the appliance in water or any other liquid.
- Do not operate the appliance with wet hands or if any connections are wet.

- If this appliance falls or accidentally becomes immersed in water, unplug it from the wall outlet immediately. Do not reach into the water.
- Do not leave the appliance unattended whilst connected to the mains power supply.
- Do not remove the appliance from the mains power supply by pulling the cord; switch it off and remove the plug by hand.
- Do not pull or carry the appliance by its power supply cord.
- Do not use the appliance for anything other than its intended use.
- Do not use any accessories other than those supplied.
- Do not use this appliance outdoors.
- Do not store the appliance in direct sunlight or in high humidity conditions.
- Do not move the appliance whilst it is in use.
- Always unplug the appliance after use and allow it to cool fully before any cleaning, user maintenance or storing away.
- Always use the appliance on a stable, heat-resistant surface, at a height that is comfortable for the user.
- This appliance should not be operated by means of an external timer or separate remote control system.
- Use of an extension cord with the appliance is not recommended.
- This appliance is intended for domestic use only. It should not be used for commercial purposes.



CAUTION: Hot surface – do not touch hot sections or heating components of the appliance.



WARNING: Keep the appliance away from flammable materials.

Dos and don'ts

DO:

Switch off the appliance and disconnect it from the mains power supply before changing or fitting attachments.

DON'T:

Use attachments if they are loose, damaged or broken.

Product group definition

This product is a Group 2 Class B appliance.

Group 2 ISM equipment: Group 2 contains all ISM equipment in which radio-frequency energy is intentionally generated and/or used in the form of electromagnetic radiation for the treatment of material, and EDM and arc welding equipment.

Class B equipment is equipment suitable for use in domestic establishments and in establishments directly connected to a low voltage power supply network which supplies buildings used for domestic purposes.

Installing the microwave

The appliance is intended to be used on the countertop only; it should not be placed in a cabinet. The appliance should be installed away from sources of heat and humidity.

To ensure sufficient ventilation, the appliance should be placed with its back against a wall, with 20 cm of free space between its sides and the wall and 30 cm of free space above it. The appliance should be at least 85 cm above floor level on a flat, stable, heat-resistant surface.

The appliance should be at least 5 m away from any TVs, radios or other appliances with antennas, as picture disturbance or noise may occur.

The appliance must be positioned so that the plug is accessible.

Do not remove the legs from the bottom of the appliance.

Blocking the intake and/or outlet openings can damage the appliance.

Only use utensils that are suitable for use in microwave ovens.

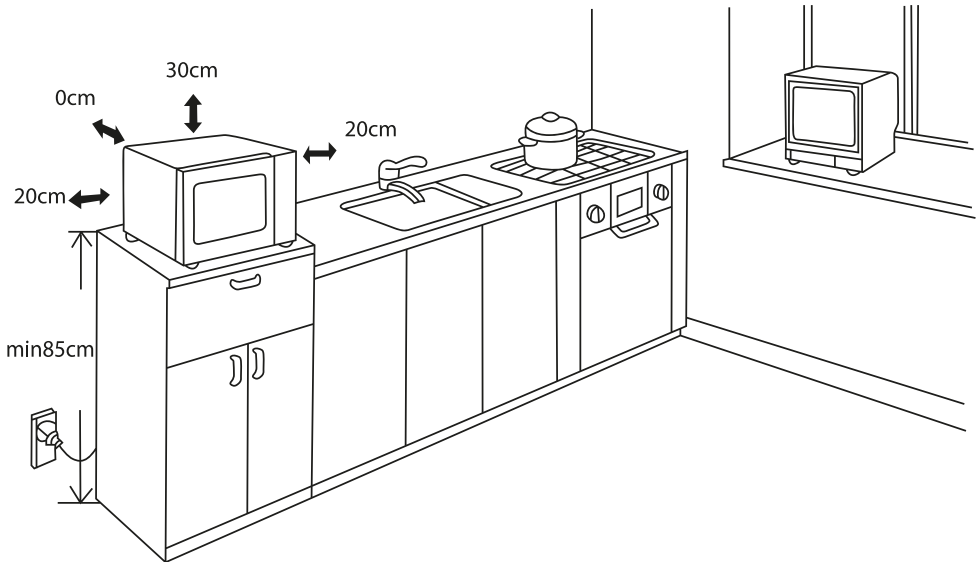

Care and maintenance

Switch off and unplug the microwave from the mains power supply and allow it to cool fully before attempting any cleaning or maintenance.

STEP 1: Wipe the exterior of the microwave with a soft, damp cloth and dry thoroughly.

STEP 2: Using a soft, damp cloth, wipe the microwave door and window, door seals and control panel to remove any spill or spatter.

STEP 3: Wipe the interior surfaces, including the waveguide cover, with a soft, damp cloth, to remove any built-up grease, as this may begin to smoke or catch fire.

Do not use harsh or abrasive cleaning detergents or scourers to clean the microwave or its accessories, as this could cause damage.



NOTE: The microwave and accessories should be cleaned after each use.



WARNING: Do not remove the waveguide cover. Failure to maintain the microwave in a clean condition could lead to deterioration of the surface that could adversely affect the life of the microwave and possibly result in a hazardous situation.

Instructions for use

Before first use

Clean the microwave following the instructions in the section entitled 'Care and maintenance'. Place the microwave onto a flat, stable, heat-resistant surface at a height that is comfortable for the user.

Ensure the turntable ring is installed in the centre of the microwave and place the glass turntable on top, ensuring the grooves on the underside of the glass turntable align with the turntable shaft. Ensure the glass turntable is in place and moves freely before use.



NOTE: When using the microwave for the first time, a slight smoke or odour may be emitted. This is normal and will soon subside. Allow for sufficient ventilation around the microwave. It is advised to heat a small cup of water in the microwave before first use as this will help to remove residue from manufacturing inside the cavity and will prevent the initial smoke or odour from affecting the taste of the food. **ALWAYS ALLOW BEVERAGES/LIQUIDS TO STAND FOR AT LEAST 20 SECONDS BEFORE HANDLING TO AVOID ERUPTIVE BOILING.**



CAUTION: The glass turntable must not be restricted during use; pay extra attention when cooking food that expands, such as popcorn, as this may obstruct the turntable movement.

Using the microwave

Power	Microwave power output	Suggested uses
Low	17%	Soften ice cream
M.Low/DEFROST	33%	Defrost food, soften butter
Med	55%	Soups, stews, microwave meals
M.High	77%	Chicken, fish, ground meat, rice
High	100%	Reheat food, boil water, vegetables

STEP 1: Plug in and switch on the microwave at the mains power supply.

STEP 2: Place the food to be microwaved onto the glass turntable and close the door. Make sure to use microwave safe plates or containers.

STEP 3: Select the desired power level using the power dial.

STEP 4: Turn the time dial to the desired cooking time.

STEP 5: Cooking will automatically begin once the desired time is set. To pause the microwave, open the door at any time. Operation will resume operation once the door is closed.

STEP 6: When the cooking time has elapsed, the bell will ring and the light will switch off.



NOTE: If food is removed before the cooking time has elapsed, ensure the time dial is reset to '0' to avoid the microwave continuing to operate whilst empty.



CAUTION: It is recommended to wear gloves when removing cooked foods from the microwave; avoid touching the heating element on the roof of the oven cavity.

Defrost function

To use the defrost function, turn the power dial to '**M.Low/DEFROST**' then use the defrost weight markings on the timer dial to begin.



NOTE: Turn food halfway through defrosting for even results.



CAUTION: Do not put thawed food back in the freezer.

Storage

Check that the microwave is cool, clean and dry before storing in a cool, dry place. Never wrap the cord tightly around the microwave; wrap it loosely to avoid causing damage.

Specifications

Product code: EK6443

Capacity: 20 L

Input: 230–240 V ~ 50 Hz

Rated input power: 1200–1270 W

Rated output power: 750–800 W

Frequency: 2450 MHz

SERVICING SAFEGUARDS FOR QUALIFIED ELECTRICIANS ONLY

CAUTION: MICROWAVE RADIATION.

1. The high voltage capacitor remains charged after disconnection; short the negative terminal of the H.V capacitor to the oven chassis using a screwdriver to discharge before touching.

2. During servicing, the below listed parts are liable to be removed and give access to potentials above 250 V to earth.

- Magnetron
- High voltage transformer
- High voltage capacitor
- High voltage diode
- High voltage fuse

3. The following conditions may cause undue microwave exposure during servicing:

- Improper fitting of magnetron.
- Improper matching of door interlock, door hinge and door.
- Improper fitting of switch support.
- The door, door seal or enclosure has been damaged.



Disposal of Waste Batteries and Electrical and Electronic Equipment



This symbol on the product, its batteries or its packaging means that this product and any batteries it contains must not be disposed of with household waste. Instead, it is the user's responsibility to hand this over to an applicable collection point for the recycling of batteries and electrical and electronic equipment. This separate collection and recycling will help to conserve natural resources and prevent potential negative consequences for human health and the environment due to the possible presence of hazardous substances in batteries and electrical and electronic equipment, which could be caused by inappropriate disposal. Some retailers provide take-back services which allow the user to return exhausted equipment for appropriate disposal. **It is the user's responsibility to delete any data on electrical and electronic equipment prior to disposal.** For more information about where to drop batteries, electrical and electronic waste off, please contact the local city/municipality office, household waste disposal service, or the retailer.

Manufactured by:
Ultimate Products UK Ltd.,
Victoria Street, Manchester OL9 0DD. **UK.**
Ultimate Products Europe Ltd.,
19 Baggot Street Lower, Dublin D02 X658. **ROI.**

MADE IN CHINA.

©Salter trademark. All rights reserved.

CD161024/MD000000/V1