

2U Vented Sliding Rack Shelf

Product ID

UNISLDSHF192 - Revision 02 or Above
UNISLDSHF19M - Revision 02 or Above

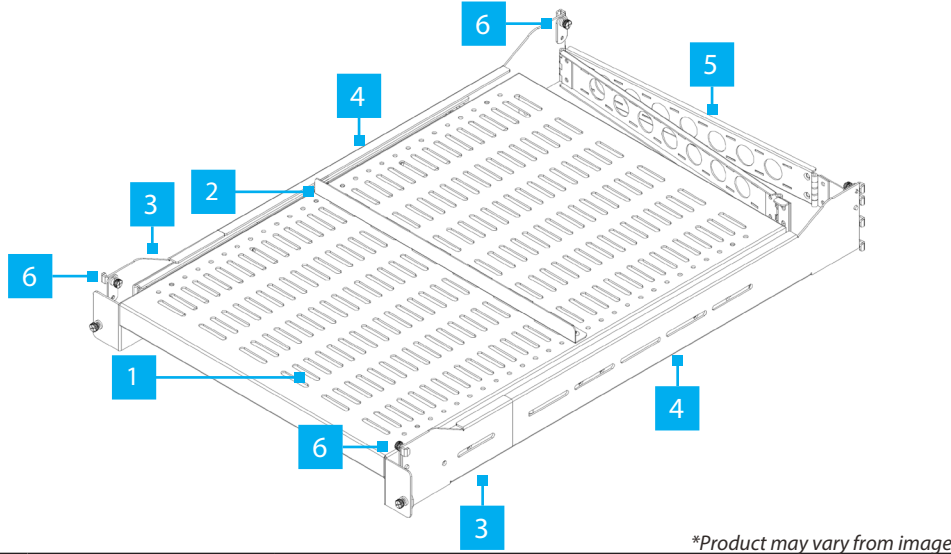

*Product may vary from image

Component	Function
1 Shelf Surface	• Place Rack Equipment
2 Rear Stop	• Prevents Equipment installed on the Shelf Surface from moving backward
3 Sliding Rail Assembly Front Bracket(x 2)	• Used to attach the Sliding Shelf onto the Front Mounting Posts of a Rack
4 Sliding Rail Assembly Rear Bracket (x 2)	• Used to attach the Sliding Shelf onto the Rear Mounting Posts of a Rack
5 Cable Management Arm	• Prevents Cables from being tangled or damaged when sliding the Shelf in or out
6 Locking Bracket (x 3)	• Secures the Sliding Rail Assembly to the Rack
Release Levers x 2 (Not Shown)	• Allows the release of the locking mechanism to retract or remove the Sliding Shelf from the Rails • See Figure 3 in the Installation section

Product Information

For the latest manuals, product information, technical specifications, and declarations of conformance, please visit:

www.StarTech.com/UNISLDSHF192

www.StarTech.com/UNISLDSHF19M

How to Identify the LOT Code Revision Number

The Revision Number (Rev #) appears as the fifth and sixth digits of the LOT code, located on the sticker affixed to the product and its packaging. If the LOT code sticker is missing, the product is Rev 01. Refer to www.StarTech.com/UNISLDSHF192 or www.StarTech.com/UNISLDSHF19M to download the manual for Revision 01.

Requirements

- Phillips Head Screwdriver
- (Optional) Cage Nut Tool

Package Contents

- Shelf Assembly x 1
- Sliding Rail Assembly x 2
- Locking Bracket x 3
- Rear Stop x 1
- Cable Management Assembly x 1
- Cable Management Locking Bracket x 1
- M5 x 8mm Screws x 2
- M5 Nuts x 2
- M4 x 8mm Screws x 2
- Quick-Start Guide x1

Warnings!

Read the entire Quick-Start Guide and ensure the instructions are fully understood before assembling and using this product.

Before adding equipment to this product, ensure this product has been properly mounted.

Never operate this product if parts are missing or damaged.

Ensure the weight of the equipment does not exceed the weight capacity of the product. If the weight capacity is exceeded, personal injury or damage to the equipment is possible. These products can support the following weights:

UNISLDSHF192 up to 50lbs (22.7kg)

UNISLDSHF19M up to 110lbs (50kg)

All four mounting points must be properly secured to each of the posts on a four-post rack.

Never exceed the maximum mounting depth specification for this shelf: 31.89in (810mm).

Installation

Install the Sliding Shelf into the Rack

1. Determine a suitable location on the **Rack** to mount the **Sliding Shelf**. The **Sliding Shelf** requires **2U** of **Mounting Space**.
2. Loosen the **Screws** along each **Sliding Rail Assembly** to be able to adjust the **Front** and/or **Rear Brackets** to the **Mounting Depth** of the Rack.

Note: Depending on **Mounting Depth** and/or setup requirements, it may be necessary to completely remove the **Screws** to reposition the **Front** and/or **Rear Brackets**.

3. Align the **Mounting Hooks** (See Figure 1) with the desired **Mounting Location** and install the **Sliding Rail Assemblies** into the **Rack**.

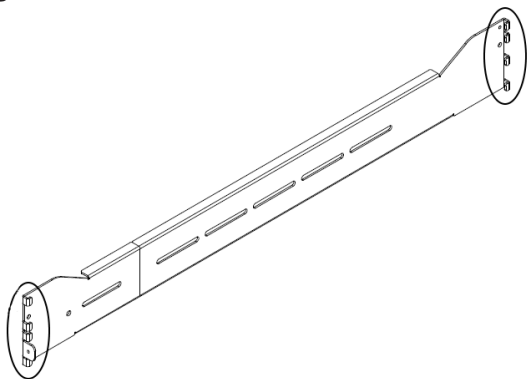

Figure 1

4. Tighten the **Screws** that were loosened in the **Step 2**.
5. Install the **Locking Brackets** (See Figure 2) on both front sides, and one on the rear, opposite to the installation of the **Cable Management Assembly Arm**. To do this, insert the pin of the **Locking Bracket** into the corresponding holes and tighten via the **Thumbscrews**.

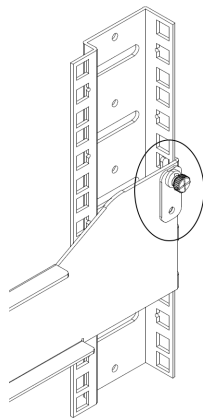

Figure 2 (Rear Locking Bracket Shown)

6. Insert the **Sliding Shelf** into the **Sliding Rail Assemblies**.
7. Pull the **Sliding Shelf** out carefully, ensuring that it **Stops** and the **Locking Mechanisms** engage.
8. To put the **Sliding Shelf** back into position, engage both **Release Levers** (See Figure 3) at the same time and gently **Push** the **Sliding Shelf** back into the **Rack**.

Note: The **Release Levers** operate in opposite directions. One moves **Down** and the other **Up**.

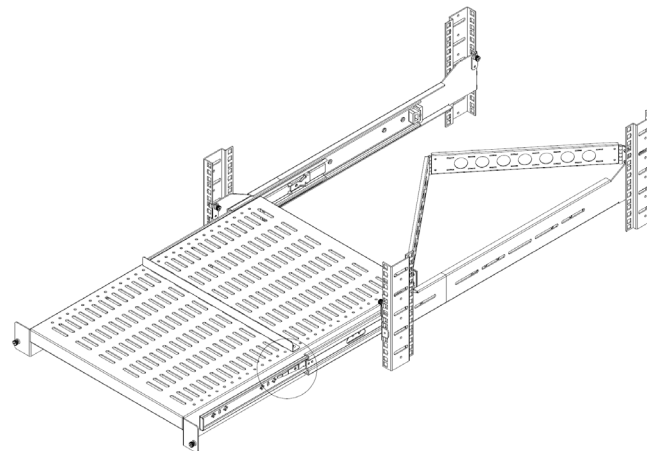

Figure 3

Install the Cable Management Assembly

Note: The **Cable Management Assembly** is reversible and can be installed in either orientation.

1. (Optional) To reverse the orientation of the **Cable Management Assembly**, detach the **Locking Bracket** (Figure 4 B) from the **Sliding Rail Assembly Rear Bracket** and remove the **Screws** that secure the **Brackets** to the **Assembly**. Flip over the **Mounting Bracket** (See Figure 4 A), and reinstall the **Screws**. Replace the **Locking Bracket** (See Figure 4 B) with the **Locking Bracket** provided.

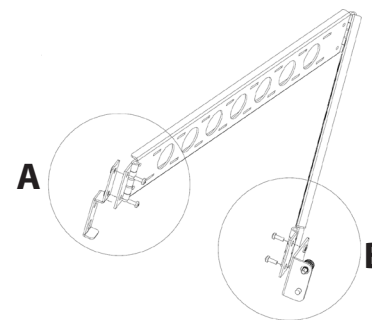

Figure 4

- Align the **Cable Management Arm Mounting Holes** (See Figure 5 A) with the **Mounting Holes** located on the **Rear** of the **Sliding Shelf**.
- Insert and tighten the provided **M4 x 8mm Screws** using a **Phillips Head Screwdriver**.
- Align the **Rear** of the **Cable Management Arm** with the **Mounting Holes** located on the **Rear** of the **Sliding Rail Assembly** (See Figure 5 B). Insert the pin of the **Locking Bracket** into the corresponding hole and tighten via **Thumbscrew**.

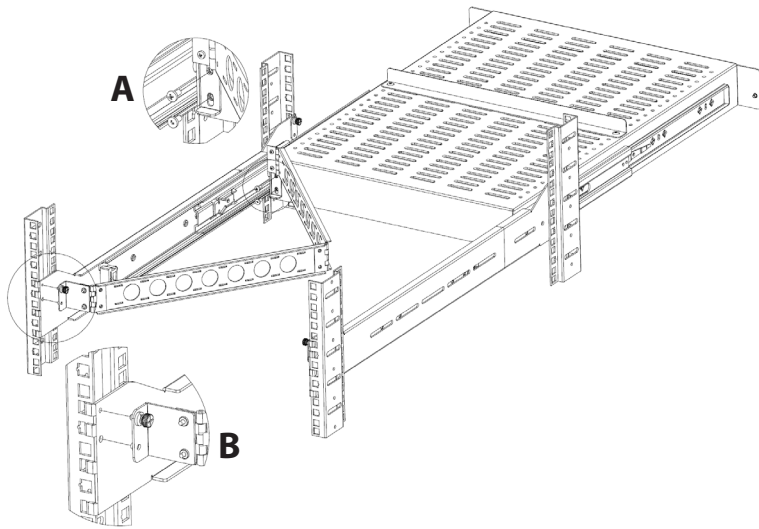

Figure 5

Install the Rear Stop Bracket

- Determine the installation location of the **Rear Stop Bracket**.
- Align the **Screw Holes** of the **Rear Stop Bracket** with the **Rear Stop Bracket Mounting Holes** (See Figure 6).
- Insert the provided **M5 x 8mm Screws** through the **Rear Stop Bracket** and the **Sliding Shelf**, securing them into the provided **M5 Nuts**. Tighten the screws using a **Phillips Head Screwdriver**.

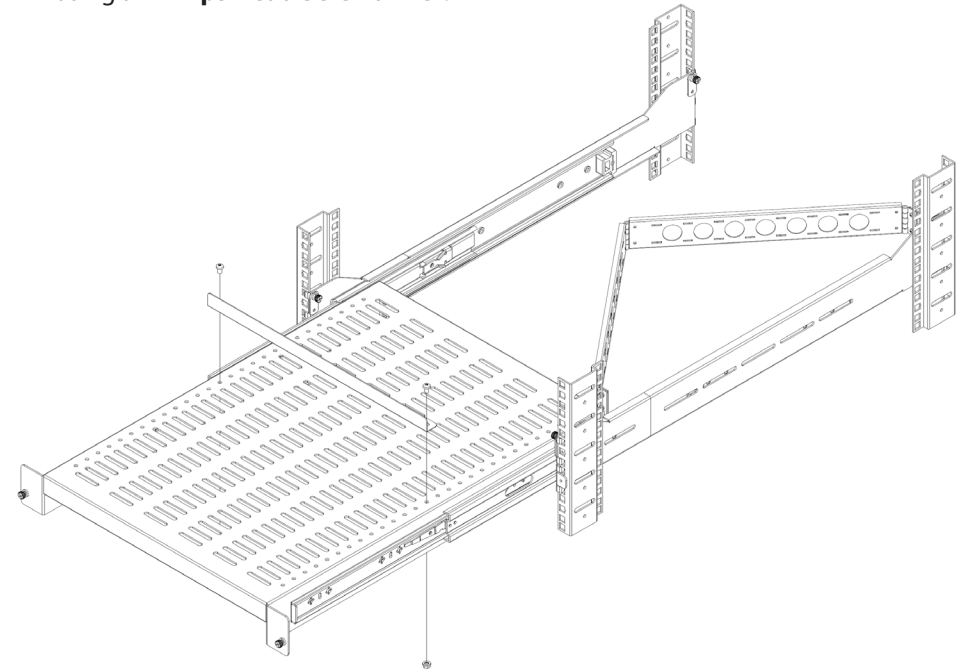

Figure 6

Regulatory Compliance

Use of Trademarks, Registered Trademarks, and other Protected Names and Symbols

This manual may make reference to trademarks, registered trademarks, and other protected names and/or symbols of third-party companies not related in any way to StarTech.com. Where they occur these references are for illustrative purposes only and do not represent an endorsement of a product or service by StarTech.com, or an endorsement of the product(s) to which this manual applies by the third-party company in question. StarTech.com hereby acknowledges that all trademarks, registered trademarks, service marks, and other protected names and/or symbols contained in this manual and related documents are the property of their respective holders.

PHILLIPS® is a registered trademark of Phillips Screw Company in the United States or other countries.

Warranty Information

This product is backed by a lifetime warranty.

For further information on product warranty terms and conditions, please refer to www.startech.com/warranty.

Limitation of Liability

In no event shall the liability of StarTech.com Ltd. and StarTech.com USA LLP (or their officers, directors, employees or agents) for any damages (whether direct or indirect, special, punitive, incidental, consequential, or otherwise), loss of profits, loss of business, or any pecuniary loss, arising out of or related to the use of the product exceed the actual price paid for the product. Some states do not allow the exclusion or limitation of incidental or consequential damages. If such laws apply, the limitations or exclusions contained in this statement may not apply to you.

Safety Measures

Assemble this product according to the instructions. Read the entire manual and ensure the instructions are fully understood before assembling and/or using this product.

Mesures de Sécurité

Assemblez ce produit conformément aux instructions. Lisez l'intégralité du manuel et assurez-vous que les instructions sont bien comprises avant d'assembler et/ou d'utiliser ce produit.

Veiligheidsmaatregelen

Monteer dit product volgens de instructies. Lees de gehele handleiding en zorg ervoor dat u de instructies volledig begrijpt voordat u dit product monteert en/of gebruikt.

Säkerhetsåtgärder

Montera produkten enligt instruktionerna. Läs hela manualen och se till att du har förstått instruktionerna innan du monterar och/eller använder produkten.

Sicherheitsmaßnahmen

Bauen Sie dieses Produkt gemäß der Anleitung zusammen. Lesen Sie das gesamte Handbuch und stellen Sie sicher, dass Sie die Anweisungen vollständig verstanden haben, bevor Sie dieses Produkt zusammenbauen und/oder verwenden.

安全対策

最初に取扱説明書を最後まで読み、本製品の組み立て方をすべて理解してから組み立て作業を始めて下さい。

Misure di Sicurezza

Leggere l'intero manuale e assicurarsi di aver compreso tutte le istruzioni prima di iniziare ad assemblare e a utilizzare questo prodotto.

Medidas de Seguridad

Monte este producto siguiendo las instrucciones. Lea todo el manual y asegúrese de que las instrucciones se entienden antes de proceder con el ensamblaje y el uso de este producto.



StarTech.com Ltd.
45 Artisans Crescent
London, Ontario
N5V 5E9
Canada

StarTech.com LLP
4490 South Hamilton
Road
Groveport, Ohio
43125
U.S.A.

StarTech.com Ltd.
Unit B, Pinnacle 15
Gowerton Road
Brackmills,
Northampton
NN4 7BW
United Kingdom

StarTech.com Ltd.
Siriusdreef 17-27
2132 WT Hoofddorp
The Netherlands

FR: startech.com/fr
DE: startech.com/de
ES: startech.com/es
NL: startech.com/nl
IT: startech.com/it
JP: startech.com/jp