

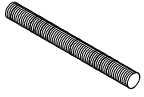









HEKMAN®

A HOWARD MILLER COMPANY

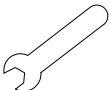
24865 QUEEN BED 24866 KING BED

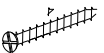
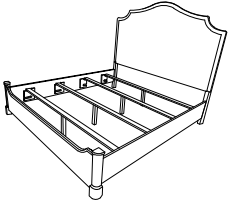
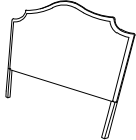
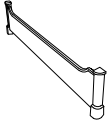
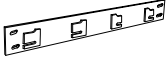
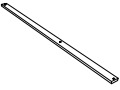
HARDWARE LIST								
A	B	C	D	E	F	G	H	I
BOLT M8 x 100 8 PCS.	HALFMOON WASHER M8 8 PCS.	SPRING W. M8 8 PCS.	HEXAGONAL BOLT M8 (8 PCS.)	ALLEN BOLT M6 X 40 (4 PCS.)	ALLEN KEY L4 (FOR ALLEN BOLT) 1 PC.	WRENCH KEY (FOR HEXA BOLT) 1 PC.	DOWEL Ø10 X 40 mm 4 PCS.	SCREW Ø8 X 1 1/2" (8 PCS.)
								

PART INSIDE						
1	2	3	4	5		
HEADBOARD (1 Pc)	FOOTBOARD (1 Pc)	SIDE RAILS (2 Pcs)	SLATS (4 Pcs)	SUPPORT SLATS (Short) (4 Pcs)	SUPPORT SLATS (Long) (4 Pcs)	
						

Assembly Instruction

STEP 1:

INSERT CONNECTING BOLT (A) & DOWEL (H) TO INSERT THAT ARE FIXED IN HEADBOARD (1) AND FOOTBOARD (2). PLACE SIDE RAILS (3) IN POSITION USING THE HALFMOON WASHER (B), SPRING WASHER (C), HEX BOLT (D) USING WRENCH KEY (G) PROVIDED.

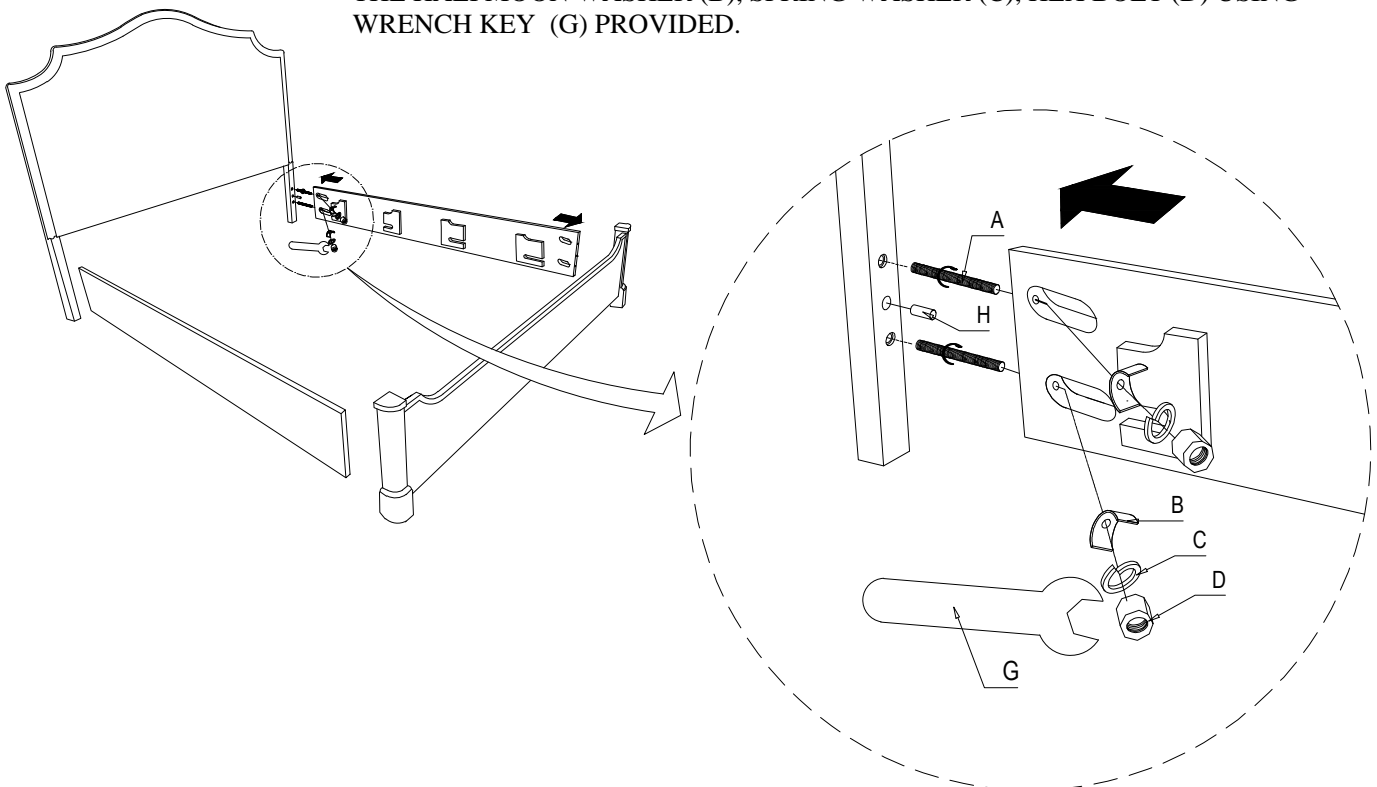

STEP 2:

PLACE SLATS IN THE WOOD RAIL BRACKET FOUND INSIDE THE SIDE RAILS USING SCREW (I) AND TIGHTEN WITH SCREW DRIVER (NOT INCLUDED).
ATTACH SUPPORT LEGS TO SLATS, FIX WITH ALLEN BOLT (D) AND TIGHTEN USING ALLEN KEY L4 (F).

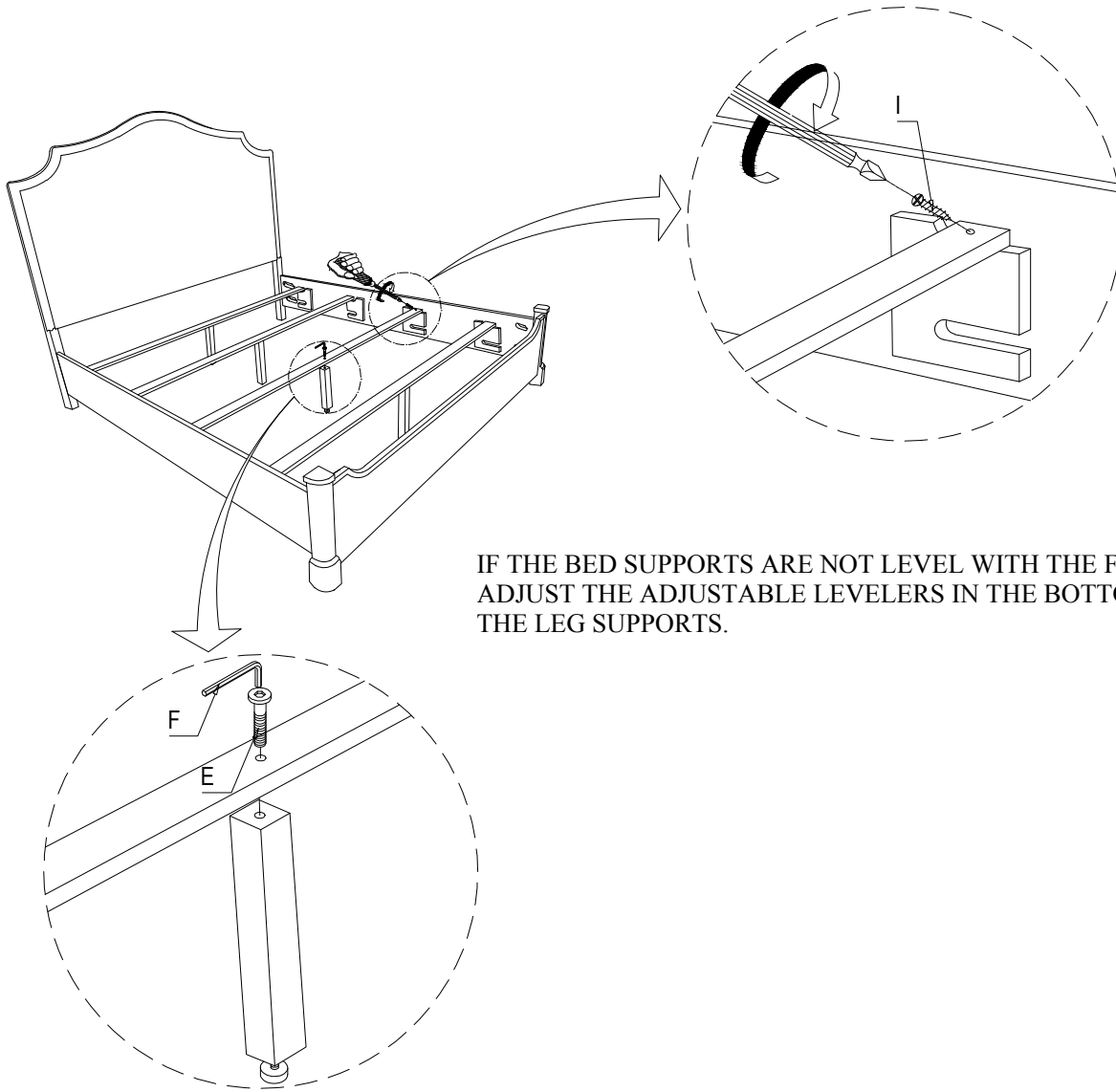

IF THE BED SUPPORTS ARE NOT LEVEL WITH THE FLOOR,
ADJUST THE ADJUSTABLE LEVELERS IN THE BOTTOM OF
THE LEG SUPPORTS.