

TWIN SPOTLIGHT MODEL #FL2

INSTRUCTION MANUAL

- READ ALL INSTRUCTIONS BEFORE PROCEEDING WITH INSTALLATION.
- WIRING THE UNIT INCORRECTLY MAY DAMAGE THE ELECTRONIC COMPONENTS INSIDE THE CONTROL MODULE, CAUSE A FIRE HAZARD, AND WILL VOID ALL WARRANTY CLAIMS.
- **Warning: This product must be installed in accordance with the applicable installation code by a person familiar with the construction and operation of the product and the hazards involved.**

SPECIFICATIONS:

- Product description: Plastic Twin Outdoor Spotlight Fixture
- Power source: 120V AC 60 Hz
- Load rating: 2x150W Max.

WHAT'S INCLUDED:

- A – Fixture mounting screw (1pc)
- B – Gasket (1pc)
- C – Wire connectors (2pcs)
- D – Outlet box mounting screws (2pcs)
- E – Ground wire screw (1pc)
- F – Mounting bar (1pc)
- G – Waterproof rubber gaskets (2pcs)
- H – Bulbs (not included)
- I – Self tapping screw with plastic bolt (1pc)

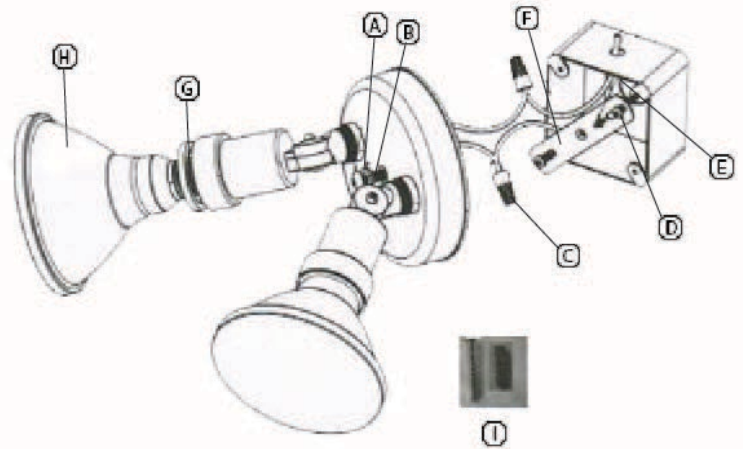

PRE-INSTALLATION GUIDELINES:

1. A qualified electrician is recommended for installation and wiring.
2. Before beginning installation, disconnect the power to the location where the light will be installed by shutting off the circuit breaker or removing the fuse at the fuse box. Shutting off a wall switch that controls the light is not sufficient to prevent electrical shock.

INSTALLING AND WIRING

1. Pull the supply wire from the house.
2. Mount the mounting bar (F) to the outlet box using the mounting screws (D)
3. Connect the wire using the wire connectors (C) as follows:
 - a. White light fixture wire to white house wire
 - b. Black light fixture to black house wire
 - c. Green (or bare copper) house wires to the ground wire screw (E).
4. Secure the light fixture to the mounting bar using the fixture mounting screw (A). Make sure to put the gasket (B) under the screw head.
5. Make sure the waterproof rubber gasket (G) is secured to the lamp-holder before installing the bulbs.

IMPORTANT: Apply a weatherproof silicone caulk or sealant around the fixture base.