

*There is more than 1 version of this model.
Page down to identify the version you have.*

PRODUCT DESCRIPTION

- Sensor operated, exposed water urinal flushometer with brass angle stop valve
- Brass construction with chrome plated finish
- Chloramine resistant seals
- 3/4" IPS inlet supply
- 3/4" top spud
- High back pressure vacuum breaker
- All flush valves are intended for use with compatible flush volume fixtures as specified by the fixture manufacturer. WaterSense® labeled flush valves should be used with a WaterSense® labeled fixture that has a compatible flush volume to ensure complete system performance.

OPERATION

- Self-cleaning Accuset™ piston flush technology
- Mechanical override
- Adjustable infrared sensor range up to 15"
- Optional 24 hour Sentinel Flush (factory setting is off)
- Operating Pressure Range: 20-125psi
- Compatible with 104630 transformer, powers up to 8 flush valves

FLOW RATE

- **8312AC10** (1.0gpf/3.8Lpf)
- **8315AC05** (0.5gpf/1.9Lpf) - WaterSense®
- **8316AC** (0.125 gpf/0.5Lpf) - WaterSense®
- **LAT8316AC** (0.125 gpf/0.5Lpf) - WaterSense®

STOP VALVE

- All metal 3/4" IPS vandal resistant angle stop with double o-ring connection
- Adjustable installation (left or right connection)

STANDARDS

- Third party certified to meet: ASSE1037 / ASME A112.1037 / CSA125.37, ASME A112.19.2 / CSA B45.1 and all applicable requirements referenced therein
- BAA
- ADA 

WARRANTY

- Warranted for 5 years against material or manufacturing defects



M•POWER™ 3/4" AC Powered Sensor Exposed Style Urinal Flush Valve

Models: 8312AC10, 8315AC05,
8316AC, LAT8316AC

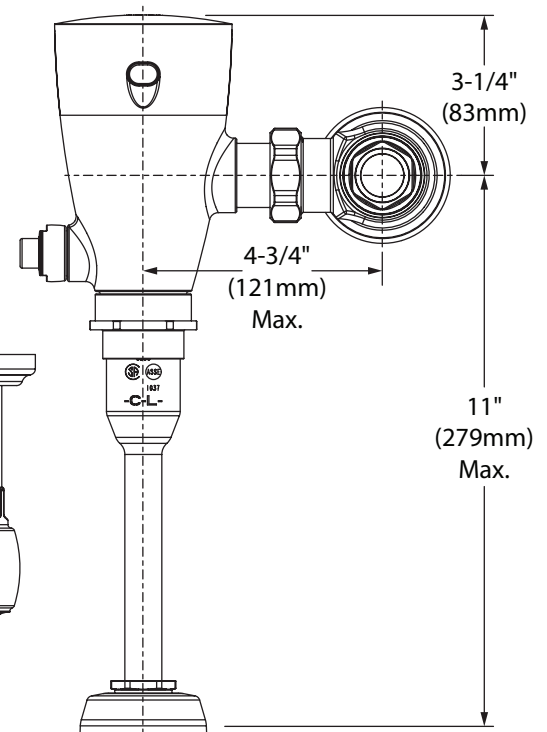
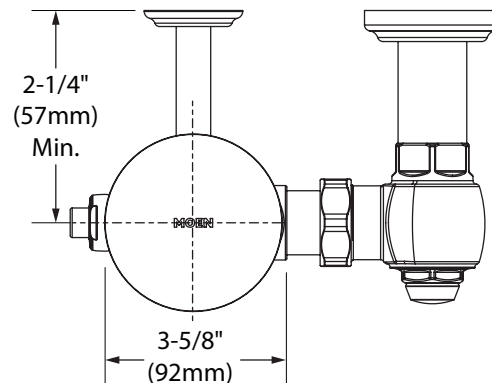
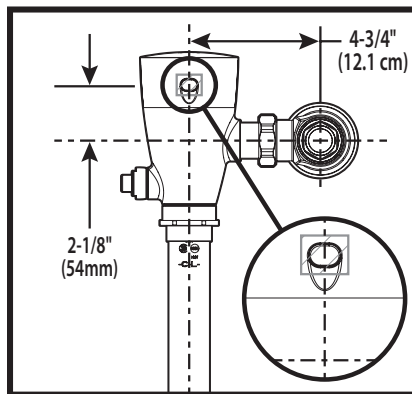

CRITICAL DIMENSIONS

(DO NOT SCALE)