

ASSEMBLY AND INSTALLATION INSTRUCTIONS

OP21835

WARNING: Turn off the main power at circuit breaker before installing fixture.
AVERTISSEMENT: Coupez la source d'alimentation principale au panneau central de disjoncteurs avant d'installer le luminaire.

NOTE: 1. Before installing, consult local electrical codes for wiring and grounding requirements.
2. Read and save these instructions.

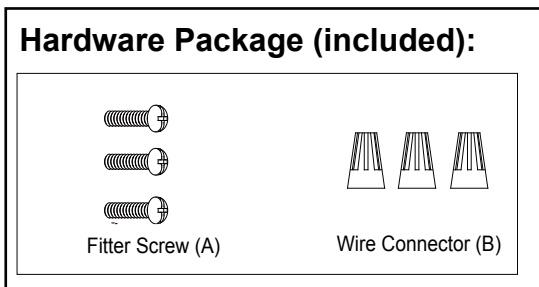

Installation Steps

Turn off the power at fuse or circuit box.

1. Attach the ring onto the top of the frame by inserting the threaded pipe, then secure it with the cap.
2. Unscrew the screws to remove the frame away from the fitter.
3. Install a bulb (not included). See relamping label at socket area or packaging for maximum wattage allowed.
4. Restore the frame back to the fitter, then secure it with screws.
5. Pull out the source wires from the post. Make wire connections using wire connectors (B) as follows:
 - Connect the hot wire (black insulation) from the fixture to the black wire from the power source.
 - Connect the neutral wire (white insulation) from the fixture to the white wire from the power source.
 - Connect the ground wire (bare wire) from the fixture to the ground wire from the post.Carefully put all of the wires back into the post.
6. Place the fitter on the top of the post, and then secure it with fitter screws (A).

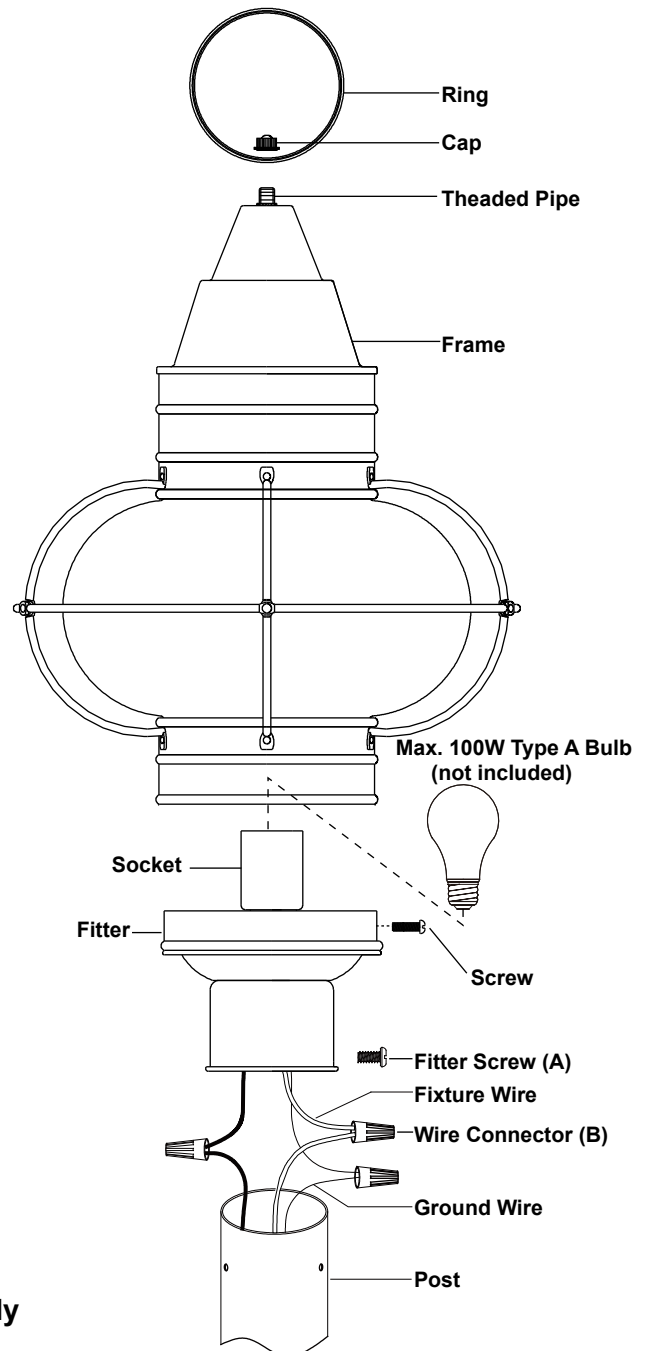

NOTE: With silicone caulk compound, caulk completely around where the fitter meets with the post surface to prevent water from seeping into the post.

Turn on the power at fuse or circuit box

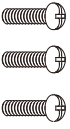

The following parts are available for reorder if damaged or missing.

Spare Parts List:

 Fitter Screw (A)	 Wire Connector (B)		Mounting Hardware 6822MM (1 SET) for OP21835TB / OP21835BBZ 6823MM (1 SET) for OP21835BN
---	---	---	--

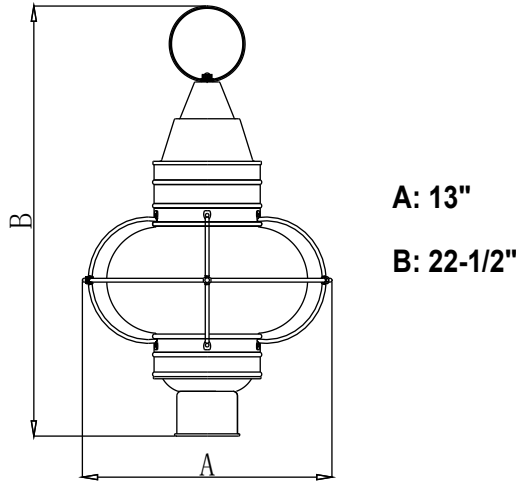

1 Year Warranty

Vaxcel warrants all of our products against defects in workmanship and finishes for one year following the date of shipment.

Exclusions: This warranty does not include the failure of products from extreme acts of nature; environmental conditions not suited for the products intended use; operation in temperatures outside of the range specified in the instruction manual; usage with improper power supply, power surges or dips. For coastal locations, some corrosion is considered normal for the environment.

Vaxcel reserves the right to repair, replace or issue a credit for any properly installed product, provided it is returned per RMA instruction. This warranty is limited to the cost of the product only and does not extend to transportation, installation or replacement costs.

How can warranty service be obtained?

info@vaxcel.com
1-800-482-9235