

Installation and Care Guide

Freestanding Bath with Heated Surface

Retain serial number for reference:
Conserver le numéro de série pour référence:
Guarde el número de serie para referencia: _____
Français, page "Français-1"
Español, página "Español-1"

THE BOLD LOOK
OF **KOHLER**®

1237788-2-G

IMPORTANT INSTRUCTIONS



WARNING: When using electrical products, basic precautions should always be followed, including the following:



WARNING: Risk of electric shock. Connect only to a circuit protected by a Ground-Fault Circuit-Interrupter (GFCI)*.



WARNING: Risk of electric shock. A qualified electrician should route all electrical wiring.



WARNING: Risk of electric shock. Disconnect power before servicing.



WARNING: Risk of property damage. Building materials and wiring should be routed away from the heat-producing components of the bath.



WARNING: Risk of injury or property damage. Please read all instructions thoroughly before beginning installation, including the following requirements.

NOTICE: Follow all plumbing, electrical, and building codes. In Canada, install this unit in accordance with the Canadian Electrical Code, Part 1.

NOTICE: Grounding is required. The unit should be installed and grounded by a qualified service representative.

NOTICE: Provide service access to the power supply and heater components.

NOTICE: If the supply cord is damaged, it must be replaced by the manufacturer, its service agent, or similarly qualified agent in order to avoid a hazard.

*Outside North America, this device may be known as a Residual Current Device (RCD).

Product Information

Electrical Requirements



WARNING: Risk of burns, fire, electric shock, or injury. Do not operate the heater if the power supply cord is damaged. For proper guidance to have this product repaired, please call: 1-800-4KOHLER from within the USA or Canada, or 001-800-456-4537 from within Mexico.

This installation must have a Class A Ground-Fault Circuit-Interrupter (GFCI)*. The GFCI protects against line-to-ground shock hazard. **Use a 120 V, 15 A, 60 Hz service for the bath.**

For Wireless Music Kit: The kit requires installation of an electrical outlet within close proximity to the amplifier location. Refer to the music kit installation instructions.

*Outside North America, this device may be known as a Residual Current Device (RCD).

Tools and Materials

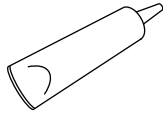
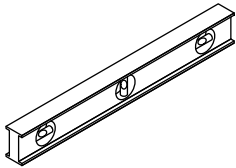
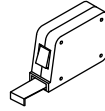
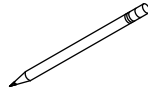
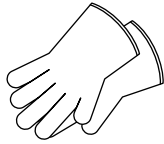
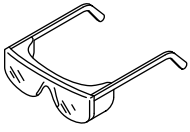

Construction
Adhesive

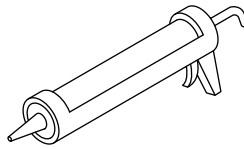

100% Silicone
Sealant

Plus:

- Drop Cloth
- Shims
- 2x4s
- Wood Blocks
- 1/2" (13 mm) Exterior Grade Plywood (for Rim-mount Faucet)

Before You Begin

NOTICE: Adequate floor support must be provided. Note the **model number** located on the heater side of the bath, then visit the product page at kohler.com for additional information.

NOTICE: Before installing a rim-mount bath faucet, refer to the specification sheet on the bath product page at kohler.com.

NOTICE: Provide adequate backer board support for a rim-mount faucet; large faucets that may be inadvertently used as a means of support are not safe for this installation.

NOTICE: For Wireless Music Kit: Refer to the instructions included with the music kit for wiring and installation details.

IMPORTANT! To ensure a successful installation, install the bath on a level, finished floor.

- Observe all local plumbing and building codes.
- Unpack and inspect the bath and components for damage. Return the bath and components to the carton until installation.
- To simplify future maintenance, make sure all plumbing connections around the bath are easily accessible.
- Carefully plan moving the bath into the installation area. This bath will not easily fit through doorways.
- Two people are needed to install this product.
- This bath is designed for freestanding installation only.
- If installing a rim-mount faucet, make sure there is no interference above or below the rim before drilling any holes.
- Illustrations shown may not look like your actual product but they still apply to this installation.
- This bath conforms to CSA B45.5/IAPMO Z124. All dimensions are nominal.

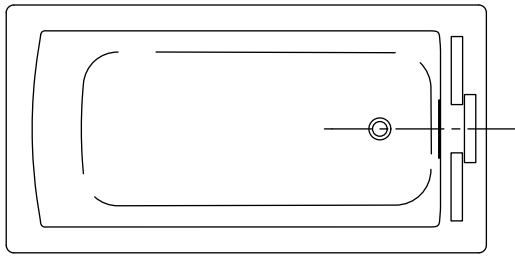

 Recommended Faucet Location (See Specification Sheet for Dimensions)

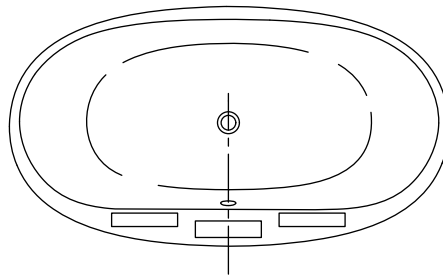
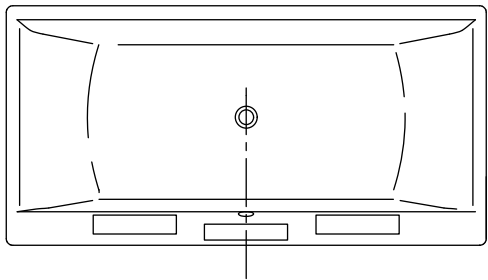
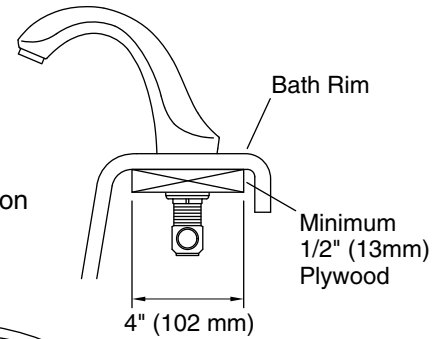

1. Prepare the Rim-Mount Faucet (Optional)

NOTICE: Before installing a rim-mount bath faucet, refer to the specification sheet on the bath product page at kohler.com for faucet location dimensions for your model.

NOTICE: To accommodate the bath shroud, use flexible connections to attach the water supplies to a rim-mount faucet.

NOTICE: For rim-mount faucet installations, route the water supply lines high enough to permit access for making the final connections from above the shroud.

- Refer to the specification sheet on the bath product page at kohler.com to determine the recommended faucet location and drain model for your bath.
- Measure and cut a piece of 1/2" (13 mm) exterior grade plywood to support the faucet. The board should be 4" (102 mm) wide. The length should extend beyond the width of the faucet holes to ensure proper support.
- Locate the faucet in the desired location on the bath rim. Make sure the faucet trim fits on the bath rim without overhanging. Make sure there is no interference above or below the rim before drilling any holes.
- Refer to the installation instructions packed with the faucet to determine faucet hole size.
- Use a pencil to mark the faucet hole centerlines. Do not drill the holes at this time.

CAUTION: Risk of product damage. To avoid scratching the bath, position a thin piece of cardboard under any clamps before tightening.

- Position the plywood on the underside of the rim, then clamp in place. Make sure the clamps do not directly contact the finished surface of the bath.
- Carefully drill the faucet holes.
- Install the valve according to the installation instructions included with the valve. **Do not** install the faucet trim until instructed.

Models with Support Blocks

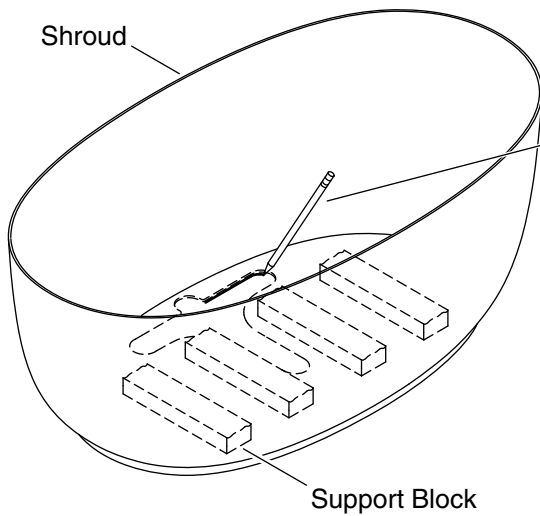

All Other Models

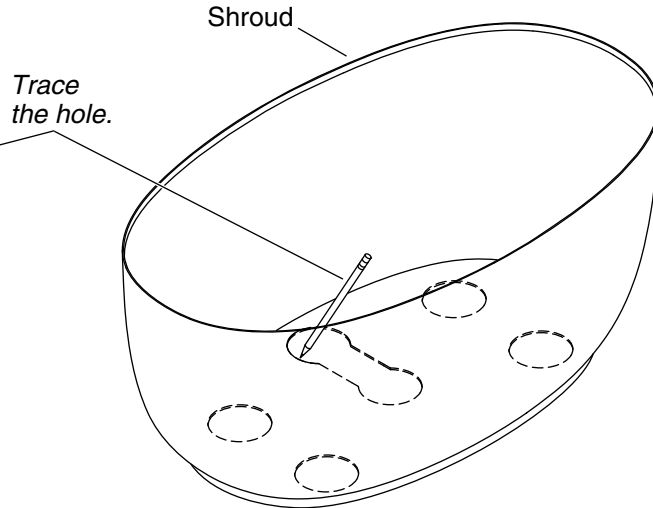

2. Prepare the Site

NOTICE: Measure your product for site preparation. Note the **model number** located on the heater side of the bath, then visit the product page at kohler.com for additional information.

NOTICE: For models with support blocks, do not attempt to remove the hardened casting material covering the blocks. The casting material is required to properly position and install the bath.

IMPORTANT! To ensure a successful installation, install the bath on a level, finished floor.

IMPORTANT! Make sure the subfloor offers adequate support for the bath.

- Temporarily position the bath and shroud in the installation location.
- If applicable, remove and discard the thin plastic film covering the support blocks.
- Verify that the **bath** is level. Shim under the shroud if necessary, and secure the shims to the floor.
- Without moving the shroud, lift and remove the bath from the shroud.
- Use the drain area cutout in the shroud to trace the drain hole area on the floor.
- Remove the shroud and set it aside.
- Refer to the specification sheet on the bath product page at kohler.com to determine any drain clearance requirements, and cut adequate floor clearance as needed.
- Refer to the specification sheet on the bath product page at kohler.com for drain height details. Position and install a standard PVC or brass bath drain pipe to the correct height.

Models with Support Blocks

All Other Models

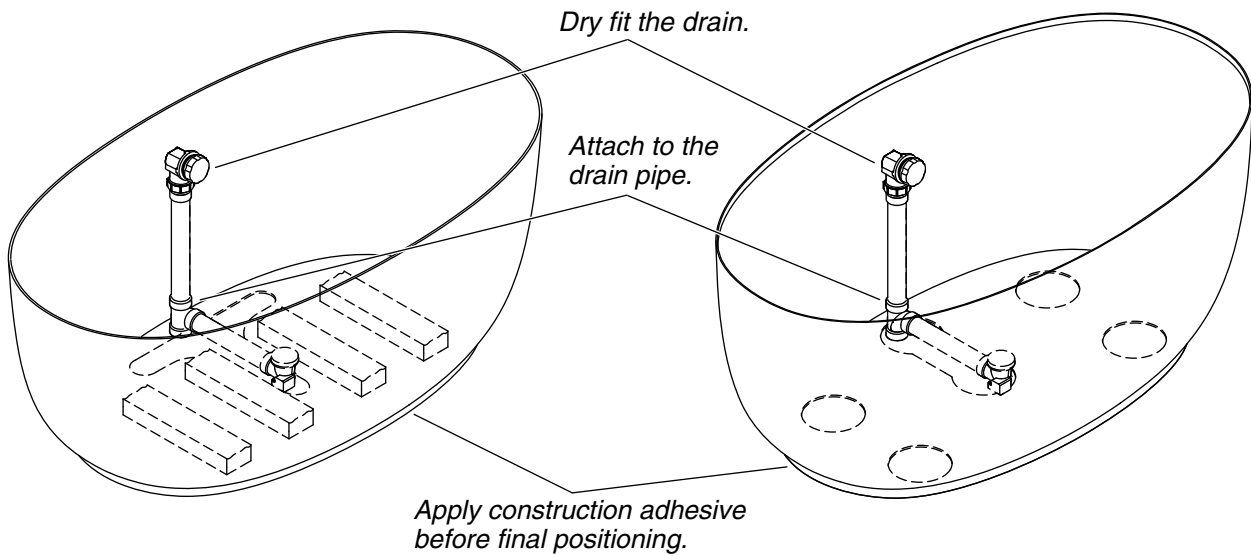

3. Prepare the Bath

NOTICE: Refer to the drain instructions to dry fit the drain to the bath. **Do not cement and complete the drain installation until instructed.**

- Dry fit the drain assembly to the bath. Refer to the drain instructions. **Do not apply sealant or cement** to the drain components at this time.
- Loosen the drain and overflow connections from the bath, and remove the drain assembly from the bath.
- Dry fit the drain assembly to the drain pipe, which has already been cut to the correct height.
- Temporarily position the shroud in place over the drain assembly.
- With help, temporarily lift the bath into place in the shroud. Make sure the bath rim is completely seated over the shroud to engage the alignment guides.
- Verify that the drain and overflow connections line up properly with the drain and overflow holes on the bath. Measure and record any adjustments needed to the drain or overflow tube lengths.
- Remove the bath and shroud, leaving the drain and overflow assembly attached to the drain pipe.
- Adjust the length of the drain tubes as needed to ensure drain alignment with the drain and overflow holes in the bath.
- Repeat these drain fit steps until the drain and overflow connections line up with the drain and overflow holes in the bath.
- Cement and assemble the drain and overflow components. Connect the drain tee to the drain pipe.
- Apply 100% silicone sealant to both sides of the drain and overflow gaskets.
- Apply slow-drying construction adhesive to the bottom of the shroud.
- Carefully position the shroud over the drain, aligning the hole with the traced mark on the floor.

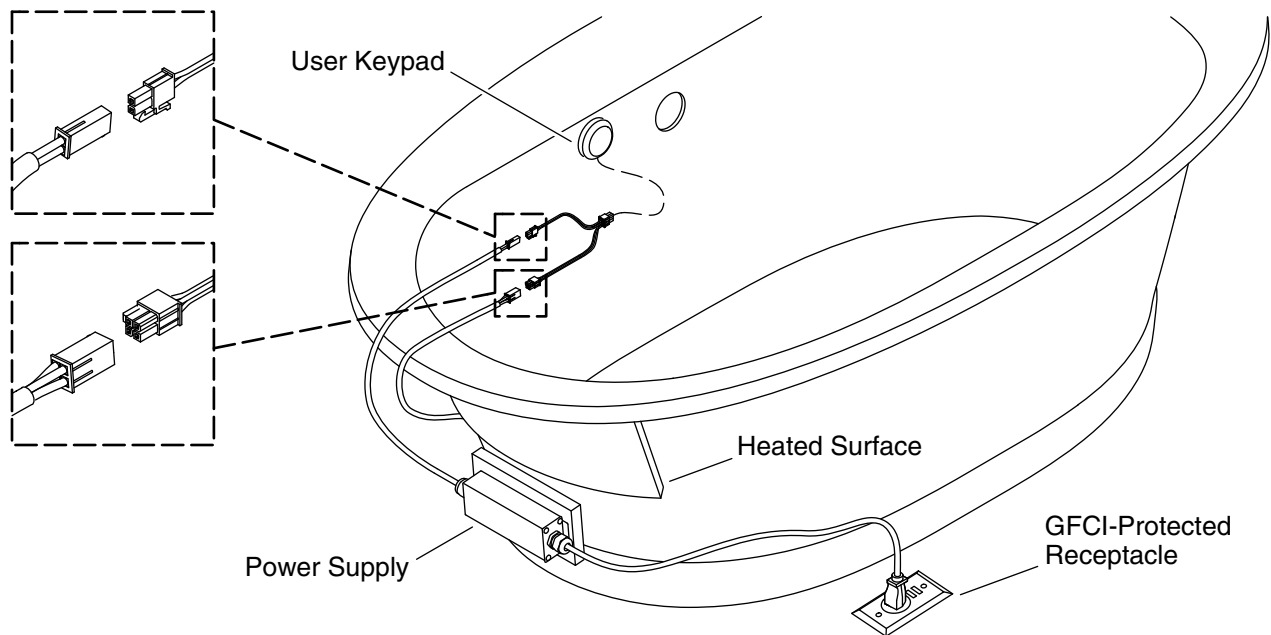

4. Install the Electrical Outlet – United States and Canada



WARNING: Risk of electric shock. Connect the power supply to a properly grounded, grounding-type receptacle protected by a Ground-Fault Circuit-Interrupter (GFCI) or Residual Current Device (RCD). Do not remove the plug grounding pin. Do not use a grounding adapter.

- Your bath is equipped with a cord and plug. The power supply has been wired at the factory. A qualified electrician must install a GFCI-protected, 120 V, 15 A, grounded outlet. Locate the outlet under the floor or inside the shroud, and within 24" (610 mm) of the heated surface power supply.
- **For Wireless Music Kit:** The kit requires installation of an electrical outlet within close proximity to the amplifier location. Refer to the music kit installation instructions.

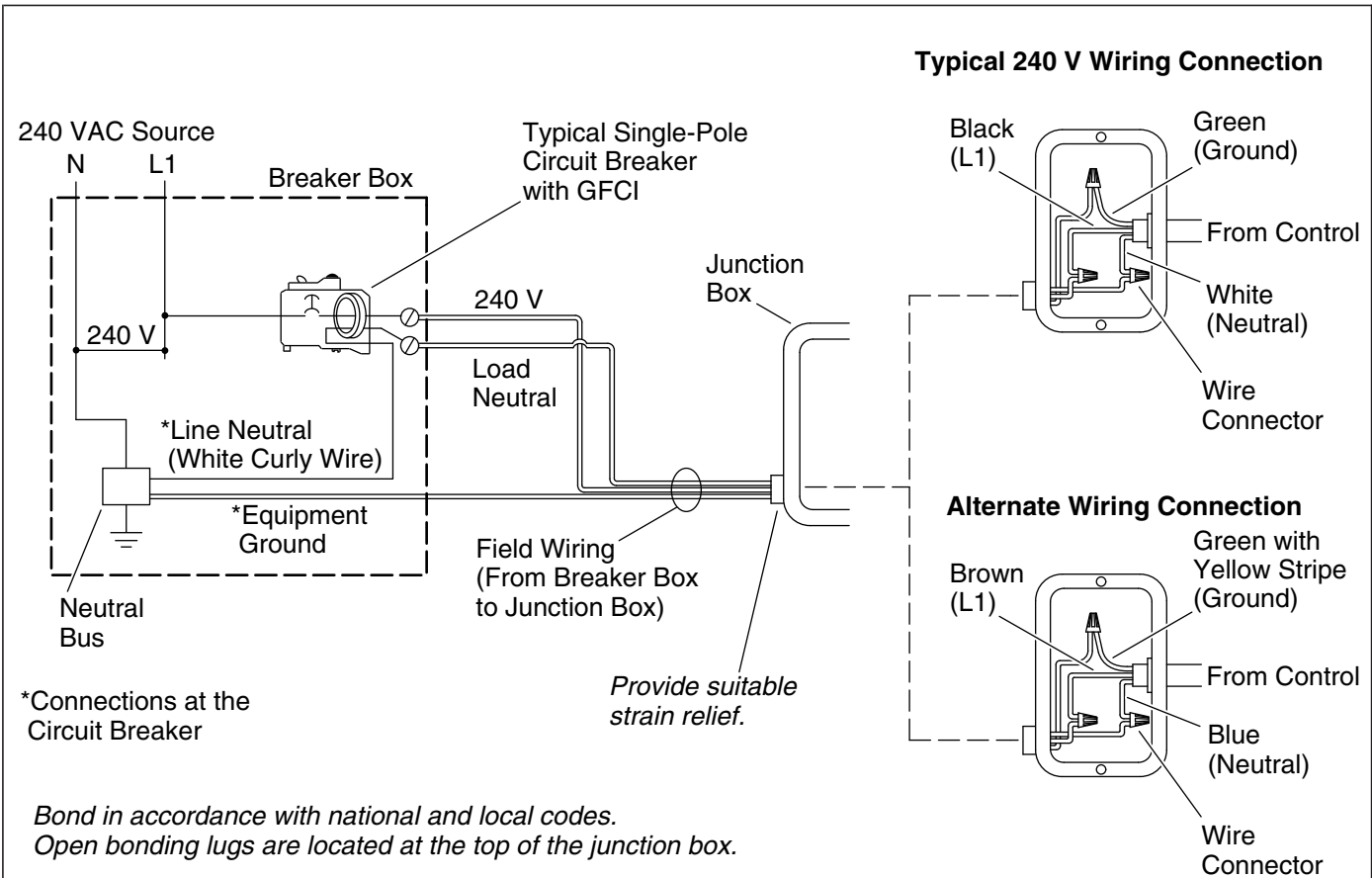

5. Make Electrical Connections – Latin America

NOTE: The electrical rating of the product is printed on a label on the lumbar end of the bath. **The bath with heated surface is designed to operate between 110 V and 240 V at either 50 Hz or 60 Hz.**



WARNING: Risk of electric shock. Disconnect the power before performing the following procedures.



WARNING: Risk of electric shock. Connect the bath to a properly grounded Ground-Fault Circuit-Interrupter (GFCI) or Residual Current Device (RCD) for protection against line-to-ground shock hazard.

IMPORTANT! The white wire should be connected to the load neutral terminal on the GFCI or RCD breaker. The green wire is the **equipment ground** and must be connected to the neutral bus in the main circuit breaker box.

IMPORTANT! Some equipment and installations vary. Reference "Alternate Wiring Connection" as shown for details.

- Follow local electrical codes. Bond in accordance with local codes.
- Remove the 120 V plug from the electrical cord on the junction box mounted to the control board.
- Connect service to the junction box with a 240 V plug (not included) or hardwire connection.
- **For Wireless Music Kit:** The kit requires installation of an electrical outlet within close proximity to the amplifier location. Refer to the music kit installation instructions.

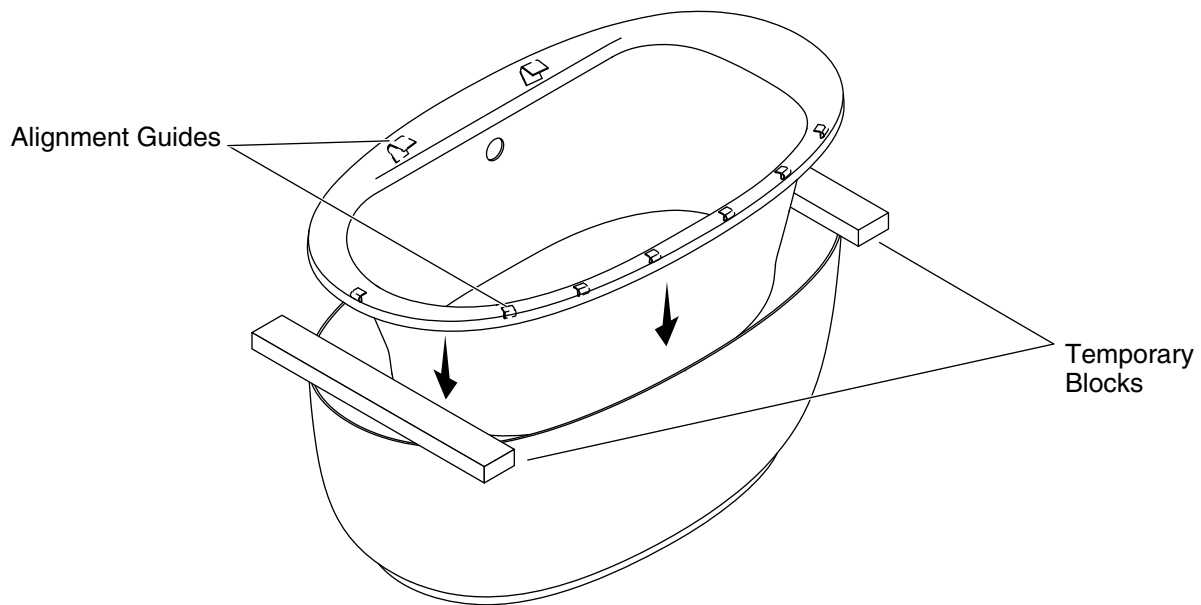

6. Install the Bath

NOTE: To provide access for securing the connections, temporarily position block spacers on opposing ends between the shroud and the bath rim. Position the blocks to avoid damaging the alignment guides located under the bath rim. The type of alignment guides may vary by product.

- With help, carefully lift the bath into place over the shroud and onto the temporary blocks.
- **For Wireless Music Kit:** Refer to the instructions included with the music kit for wiring and installation details, and make the final electrical connections.
- Secure all drain connections and fittings according to the drain instructions.
- For a rim-mount faucet, install the faucet and trim according to the faucet and trim instructions. Make sure there is adequate support under the bath rim to support the faucet. Refer to the "Prepare the Rim-Mount Faucet (Optional)" section.
- Plug the power cord into the installed outlet.
- Carefully remove the blocks and make sure the bath rim engages the top of the shroud on all sides. Ensure **all** alignment guides are inside the shroud; there should be no gap between the bath and the shroud.
- Install the drain flange and overflow cover according to the drain instructions.
- Close the bath drain. Fill the bath to the overflow, and check for leaks.
- If desired, apply a thin, continuous bead of clear or color-matched 100% silicone sealant to the seam between the shroud and the finished floor.

Test Run the Bath

- Check all electrical connections and make sure the electrical power to the bath is on.
- Operate the user keypad to test the temperature settings.
- For additional information on bath operation, refer to the "Operating Instructions" section.

Operating Instructions

IMPORTANT SAFETY INSTRUCTIONS

READ AND FOLLOW ALL INSTRUCTIONS

SAVE THESE INSTRUCTIONS

INSTRUCTIONS PERTAINING TO A RISK OF FIRE, ELECTRIC SHOCK, OR INJURY TO PERSONS



WARNING: When using electrical products, basic precautions should always be followed, including the following:



DANGER: Risk of accidental injury or drowning. To reduce the risk of injury, do not permit children to use this unit unless they are closely supervised at all times.



WARNING: Risk of personal injury. To avoid injury, exercise care when entering or exiting the bath.



WARNING: Risk of electric shock. Do not permit electric appliances (such as a hair dryer, lamp, telephone, radio, or television) within 5' (1.5 m) of this bath.



WARNING: The use of alcohol, drugs, or medication can greatly increase the risk of fatal hyperthermia. Prolonged immersion in hot water may induce hyperthermia. Hyperthermia occurs when the internal temperature of the body reaches a level several degrees above the normal body temperature of 98.6°F (37°C). The symptoms of hyperthermia include an increase in the internal temperature of the body, dizziness, lethargy, drowsiness, and fainting. The effects of hyperthermia include: (a) failure to perceive heat, (b) failure to recognize the need to exit the bath, (c) unawareness of impending hazard, (d) fetal damage in pregnant women, (e) physical inability to exit the bath, and (f) unconsciousness resulting in the danger of drowning.



WARNING: Risk of hyperthermia. People using medications and/or having an adverse medical history should consult a physician before using a bath equipped with a heater.



WARNING: Risk of fetal injury. Pregnant or possibly pregnant women should consult a physician before using the bath with heated surface.



WARNING: Risk of hyperthermia or drowning. Do not use the bath with heated surface immediately following strenuous exercise.



WARNING: Risk of hyperthermia or drowning. Water temperature in excess of 100°F (38°C) may cause injury. Test and adjust the water temperature before use.

Use this heated bath only for its intended purpose as described in this guide. Do not use attachments not recommended by Kohler Co.

The heated bath must be connected only to a supply circuit that is protected by a Ground-Fault Circuit-Interrupter (GFCI)*. Such a GFCI should be provided by the installer and should be tested on a routine basis. To test the GFCI, press the test button. The GFCI should interrupt power. Press the reset button. Power should be restored. If the GFCI fails to operate in this manner, the GFCI is defective. If the GFCI interrupts power to the bath without the test button being pressed, a ground current is flowing, indicating the possibility of an electric shock. Do not use this heated bath. Disconnect the heater and have the problem corrected by a qualified service representative before using.

Your new KOHLER bath has been listed by Underwriter's Laboratories, ensuring safety for you and your family. This bath also conforms to rigid ANSI and IAPMO standards set within the plumbing industry.

* Outside North America, this device may be known as a Residual Current Device (RCD).

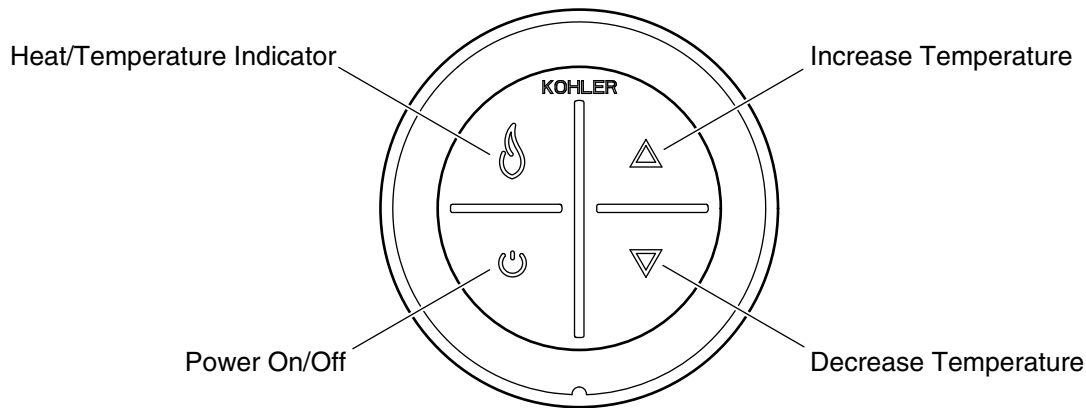

Operating Instructions

Keypad Operation

- **Power Icon** - Turns the heater ON and OFF.
- **Heat/Temperature Indicator** - The [Flame] icon illuminates yellow, orange, or red depending on the heat level. Yellow indicates low heat, orange indicates medium heat, and red indicates high heat.
- **Up Arrow** - Increases the temperature.
- **Down Arrow** - Decreases the temperature.

NOTICE: The heater will remain on until it is manually turned OFF by pressing the [Power] icon.

NOTE: After 60 minutes of inactivity, the heater will automatically reset to low heat if the temperature was set to medium or high.

NOTE: The heater will turn on at the last selected temperature setting.

Error Codes

- **Heat indicator blinking red** - The heater is not functioning.
- **Heat indicator blinking yellow** - The temperature sensor is not functioning or is loose.
- Refer to the "Troubleshooting" section to troubleshoot any problems.

Confirm Heating System Operation

- Press the [Power] icon on the user keypad.
- Observe that the heat indicator turns yellow and the heater produces low heat.
- Press the [Up] arrow. Verify that the heat indicator turns orange and the temperature increases.
- Press the [Up] arrow a second time. Verify that the heat indicator turns red and the temperature increases.
- Press the [Down] arrow. Verify that the heat indicator turns orange and the temperature decreases.
- Press the [Down] arrow a second time. Verify that the heat indicator turns yellow and the temperature decreases.
- Press the [Power] icon to turn the heater OFF.

Care and Cleaning

For best results, keep the following in mind when caring for your KOHLER product:

- Always test your cleaning solution on an inconspicuous area before applying to the entire surface.
- Wipe surfaces clean and rinse completely with water immediately after applying cleaner. Rinse and dry any overspray that lands on nearby surfaces.
- Do not allow cleaners to soak on surfaces.
- Use a soft, dampened sponge or cloth. Never use an abrasive material such as a brush or scouring pad to clean surfaces.

For detailed cleaning information and products to consider, visit www.kohler.com/clean. To order Care & Cleaning information, call 1-800-456-4537.

Warranty

ONE-YEAR LIMITED WARRANTY

KOHLER plumbing products are warranted to be free of defects in material and workmanship for one year from date of installation.

Kohler Co. will, at its election, repair, replace or make appropriate adjustment where Kohler Co. inspection discloses any such defects occurring in normal usage within one (1) year after installation. Kohler Co. is not responsible for removal or installation costs. **Use of in-tank toilet cleaners will void the warranty.**

To obtain warranty service contact Kohler Co. either through your Dealer, Plumbing Contractor, Home Center or E-tailer, or by writing Kohler Co., Attn.: Customer Care Center, 444 Highland Drive, Kohler, WI 53044, USA, or by calling 1-800-4-KOHLER (1-800-456-4537) from within the USA and Canada, and 001-800-456-4537 from within Mexico, or visit www.kohler.com within the USA, www.ca.kohler.com from within Canada, or www.mx.kohler.com in Mexico.

IMPLIED WARRANTIES INCLUDING THAT OF MERCHANTABILITY AND FITNESS FOR A PARTICULAR PURPOSE ARE EXPRESSLY LIMITED IN DURATION TO THE DURATION OF THIS WARRANTY. KOHLER CO. AND/OR SELLER DISCLAIM ANY LIABILITY FOR SPECIAL, INCIDENTAL OR CONSEQUENTIAL DAMAGES. Some states/provinces do not allow limitations on how long an implied warranty lasts, or the exclusion or limitation of special, incidental or consequential damages, so these limitations and exclusions may not apply to you. This warranty gives you specific legal rights. You may also have other rights which vary from state/province to state/province.

This is Kohler Co.'s exclusive written warranty.

Troubleshooting

This section is for general aid only. A Kohler Co. Authorized Service Representative or qualified electrician should correct any electrical problems. For warranty service, call 1-800-4KOHLER from within the USA and Canada, or 001-800-456-4537 from within Mexico.

NOTE: The product model number is located on the heater side of the bath.

NOTE: For service parts information, visit your product page at kohler.com.

Troubleshooting Table

Symptoms	Probable Cause	Recommended Action
1. Heated bath does not turn on.	A. No power to power supply. B. User keypad cable loose or damaged. C. User keypad does not work. D. Power supply does not work.	A. Set/reset GFCI or RCD breaker; check wiring. B. Check wire connections. If necessary, replace user keypad cable. C. Check wire connections. Replace user keypad. D. Replace power supply.
2. Bath is turned on, but there is little or no heat.	A. Heater cable loose or damaged.	A. Check wire connections. If necessary, replace heater cable.

Troubleshooting (cont.)

Troubleshooting Table

Symptoms	Probable Cause	Recommended Action
	<ul style="list-style-type: none"> B. Heater/insulation loose on the bath. C. Heat indicator is yellow or orange. D. Heater does not work. E. Temperature sensor does not work. 	<ul style="list-style-type: none"> B. Secure the heater/insulation to the bath. C. Press the [Up] arrow to increase temperature. D. Replace the heater. E. Replace the heater.
<p>3. Temperature does not automatically reset to low after 1 hour.</p>	<ul style="list-style-type: none"> A. Temperature sensor does not work. 	<ul style="list-style-type: none"> A. Replace the heater and/or keypad.
<p>4. Heat indicator is blinking red.</p>	<ul style="list-style-type: none"> A. Heating system needs to be reset. B. Heater does not work. 	<ul style="list-style-type: none"> A. Press the [Power] icon to turn the power OFF. Wait 10 seconds, then turn the power ON. B. Replace the heater.
<p>5. Heat indicator is blinking yellow.</p>	<ul style="list-style-type: none"> A. Heating system needs to be reset. B. Temperature sensor does not work. 	<ul style="list-style-type: none"> A. Press the [Power] icon to turn the power OFF. Wait 10 seconds, then turn the power ON. B. Replace the heater.