

Stacking filled product with snap-on lid 6084  
Pipeline Item 63281

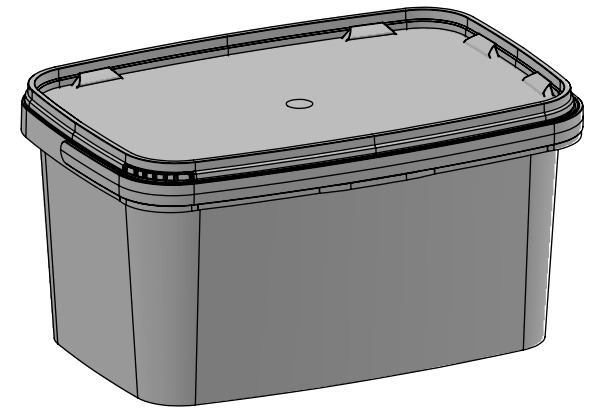

With plastic handle 8938

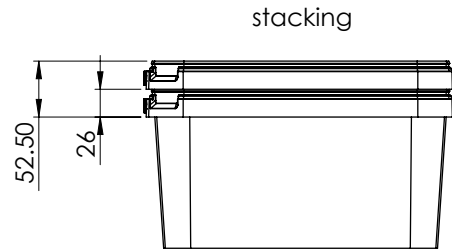
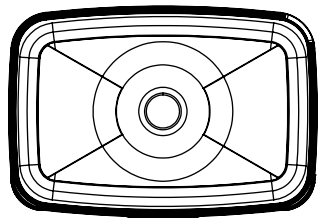
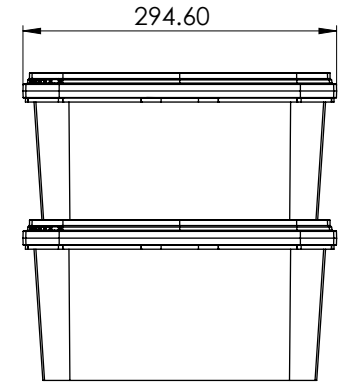
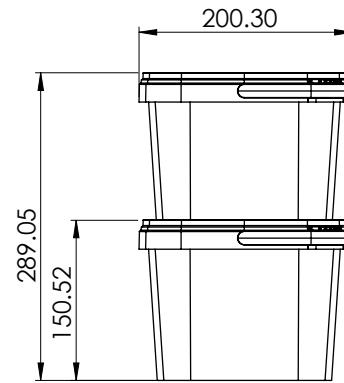
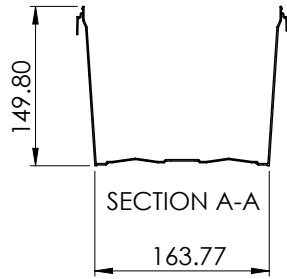
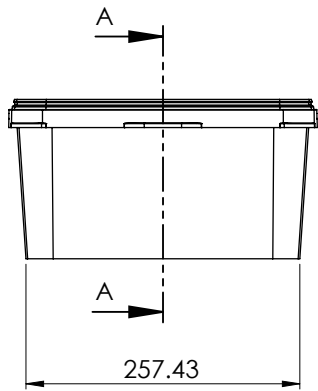
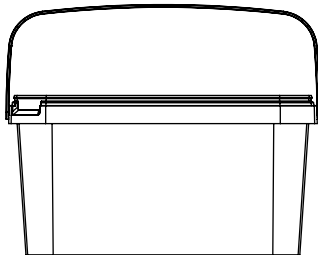

Volume under lid 5.88L

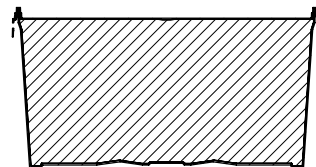

**DISCLAIMER**

THIS INFORMATION IS PROVIDED AS A GENERAL GUIDE, INCLUDING DIMENSIONS. IT IS THE CUSTOMER'S RESPONSIBILITY TO SELECT THE PROPER CONTAINER FOR PRODUCT AND APPLICATION COMPATIBILITY.

DISTRIBUTED BY:



REF NO.:

DWG31769

DESCRIPTION:

5.1 Liter PP Square OH Pail, Supercube with White Plastic Handle