



bestchoiceproducts



INSTRUCTION MANUAL

4-Tier Computer Workstation



Fasten screws loosely
during initial assembly.
Do not tighten screws
until item is completely
assembled.

bestchoiceproducts.com

! NOTICE

Please retain these instructions for future reference.

- Please do not exceed the weight limitations of this item.
- Do not stand on or use any part of this item as a step ladder.
- Fasten screws loosely during initial assembly. Do not tighten screws until item is completely assembled.
- Firmly secure all bolts, screws, and knobs before use.
- Reconfirm that all bolts, screws, and knobs are secure every 90 days.
- Do not use or store this item in the proximity of open flame or flammable/combustible chemicals.
- If any parts are missing, broken, damaged, or worn, stop using this item until repairs are made and/or factory replacement parts are installed.
- Do not use this item in a way inconsistent with the manufacturer's instructions as this could void the product warranty.

TOOLS REQUIRED



SMALL
WRENCH



PHILLIPS
SCREWDRIVER



300 LBS
TOTAL
CAPACITY



40 LBS
SHELF
CAPACITY



180 LBS
TABLE
CAPACITY



1 PERSON
ASSEMBLY



APPROXIMATELY
30 MIN.
ASSEMBLY

HARDWARE

A

M6 X 45MM
BOLT

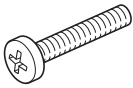

4 PCS

B

M7 X 50MM
BOLT

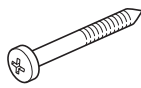

12 PCS

C

M6 X 30MM
BOLT

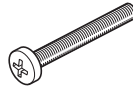

4 PCS

D

M6 X 40MM
BOLT

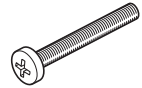

4 PCS

E

M6 X 12MM
BOLT



2 PCS

F

M6 X 28MM
BOLT

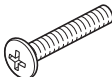

8 PCS

G

M6 CAP NUT



14 PCS

H

FOOT CAPS

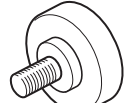

6 PCS

I

STICKER



4 PCS

PARTS

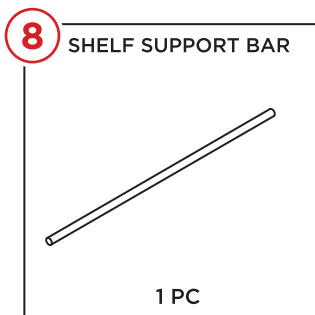
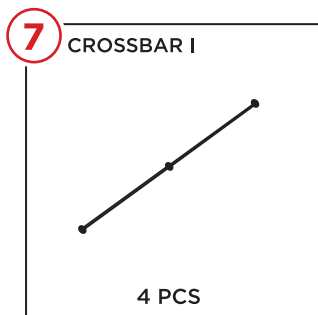
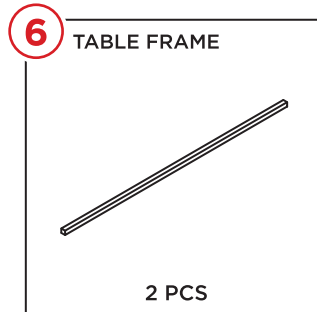
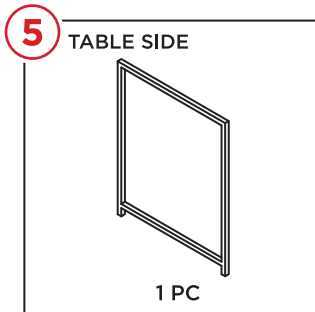
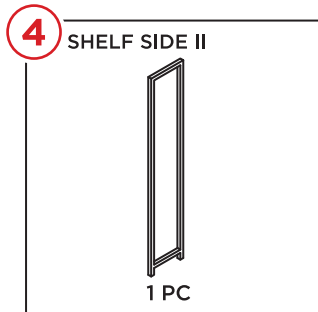
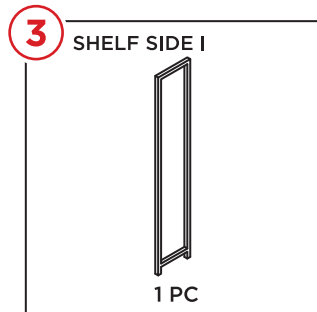
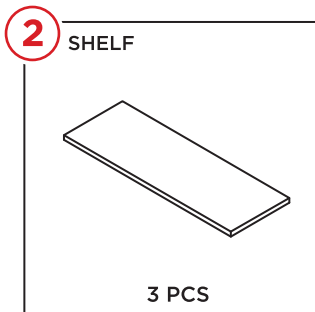
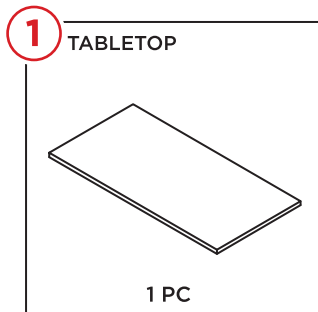

PRODUCT ASSEMBLY

1

Attach three part 2 shelves to the part 3&4 shelf sides with twelve part B bolts. Four bolts per shelf.

Screw four part H foot caps into the part 3&4 shelf sides, two per side.

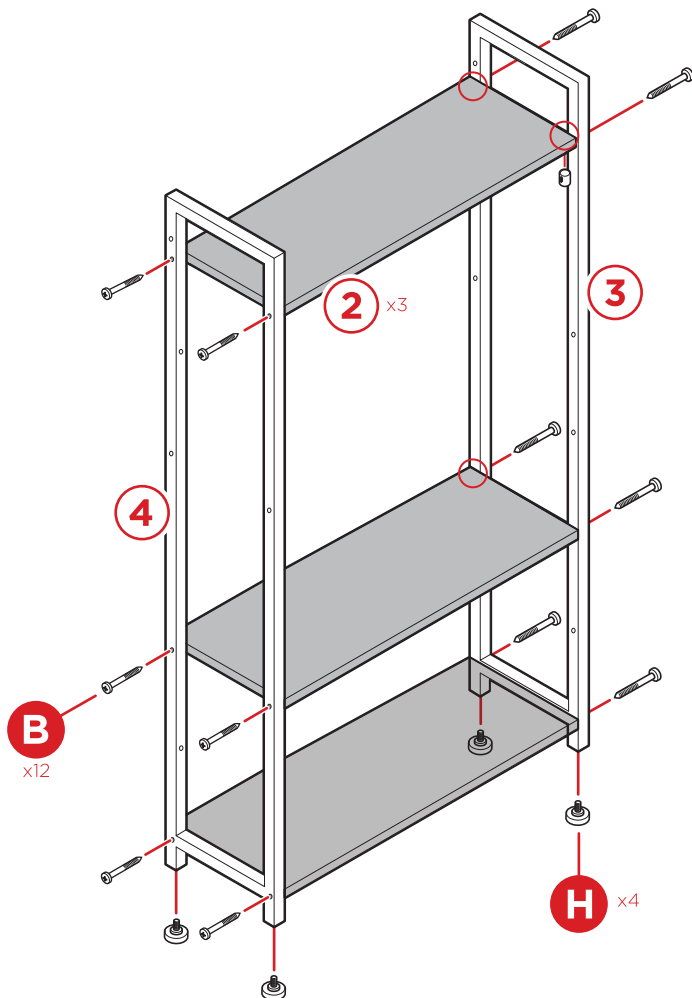

If necessary, assemble shelf with it laying on its side.

PRODUCT ASSEMBLY

2

Attach the part 8 shelf support bar to the part 3 and part 4 shelf sides with two part D bolts. Attach two part 7 crossbars to the shelf assembly with four part F bolts and four part G nut caps. Secure the crossbars with one part E bolt and one part G nut cap.

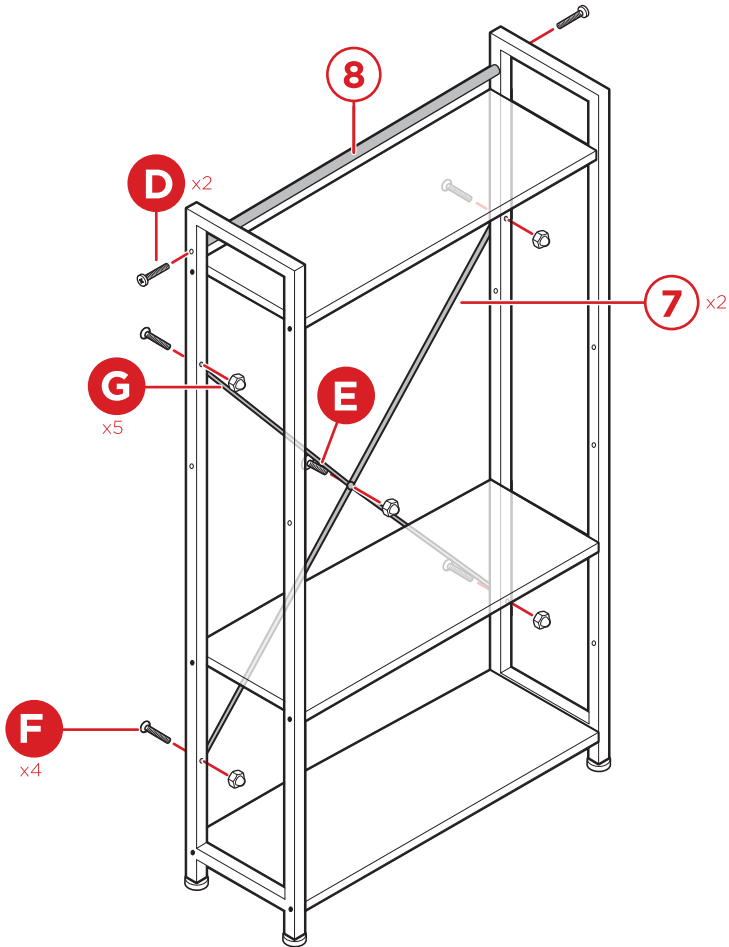

If necessary, assemble shelf with it laying on its side.

PRODUCT ASSEMBLY

3

Attach two part 6 table frames to the part 5 table side with two part D bolts. Screw in two part H foot caps.

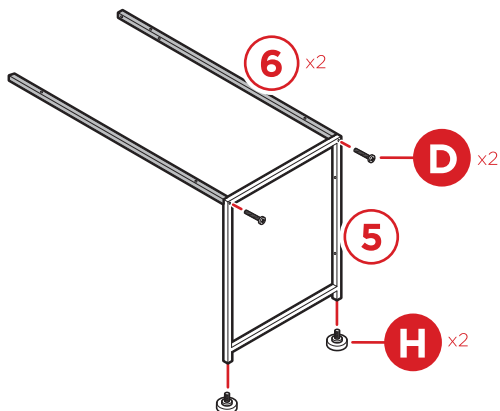

4

Attach the two part 6 table sides to the shelf assembly with four part A bolts and four part G cap nuts.

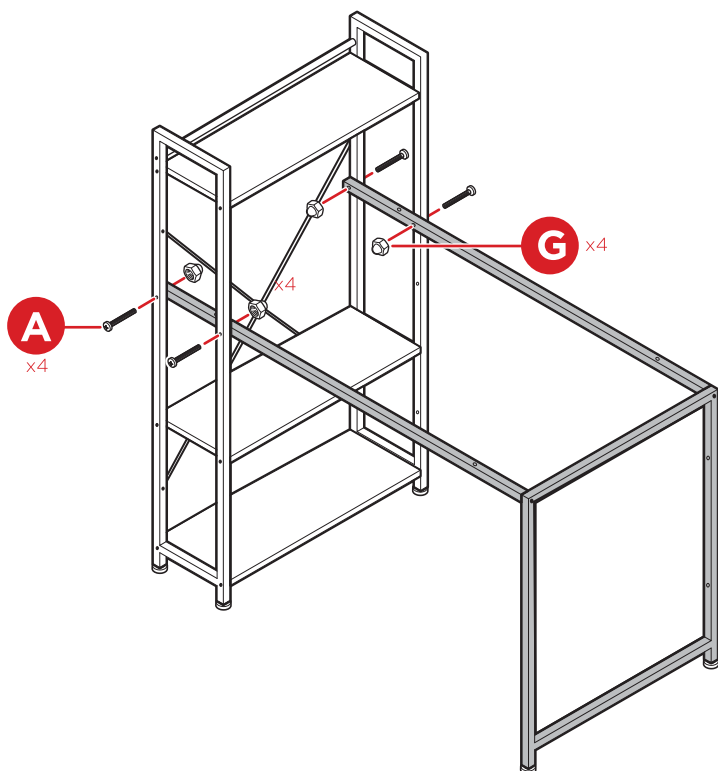

PRODUCT ASSEMBLY

5

Attach the part 1 tabletop to the table frame with four part C bolts.

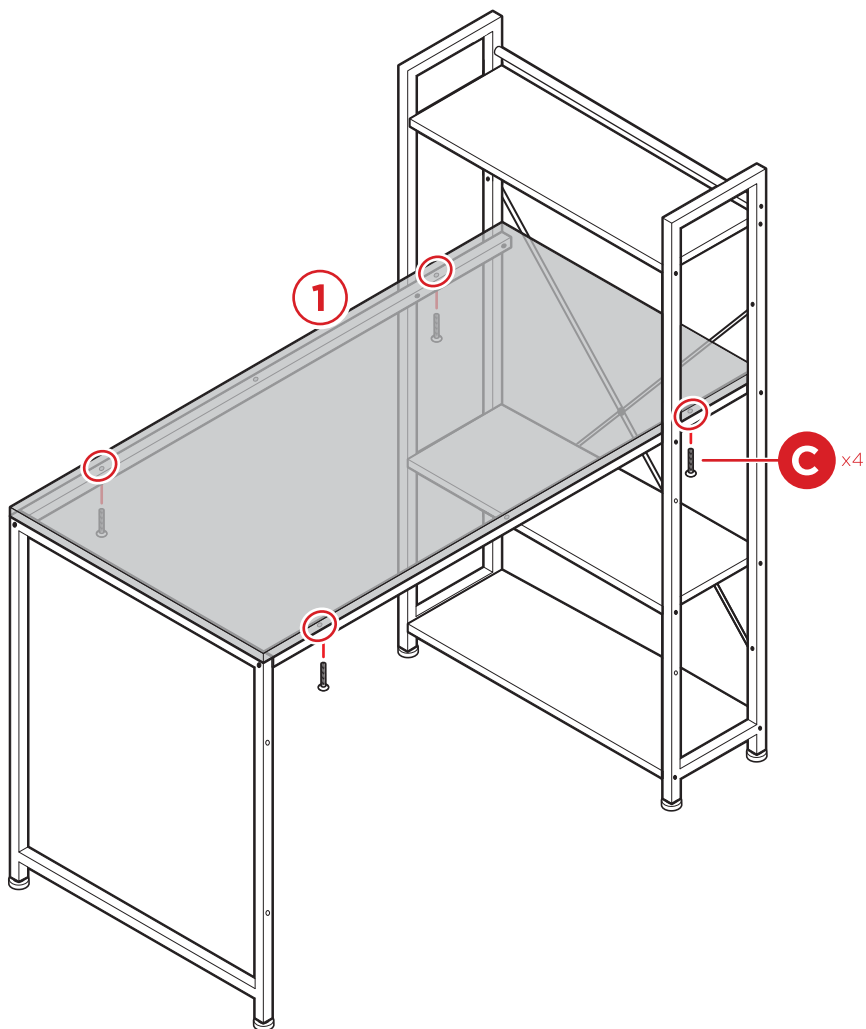

BACK VIEW

PRODUCT ASSEMBLY

7

To orient the shelf on the left-hand side, follow steps 1-4 and attach the part 7 crossbars to the part 3 shelf side and part 5 table side with four part F bolts and four part G nut caps. Secure the crossbars to each other with a part E bolt and part G nut cap.

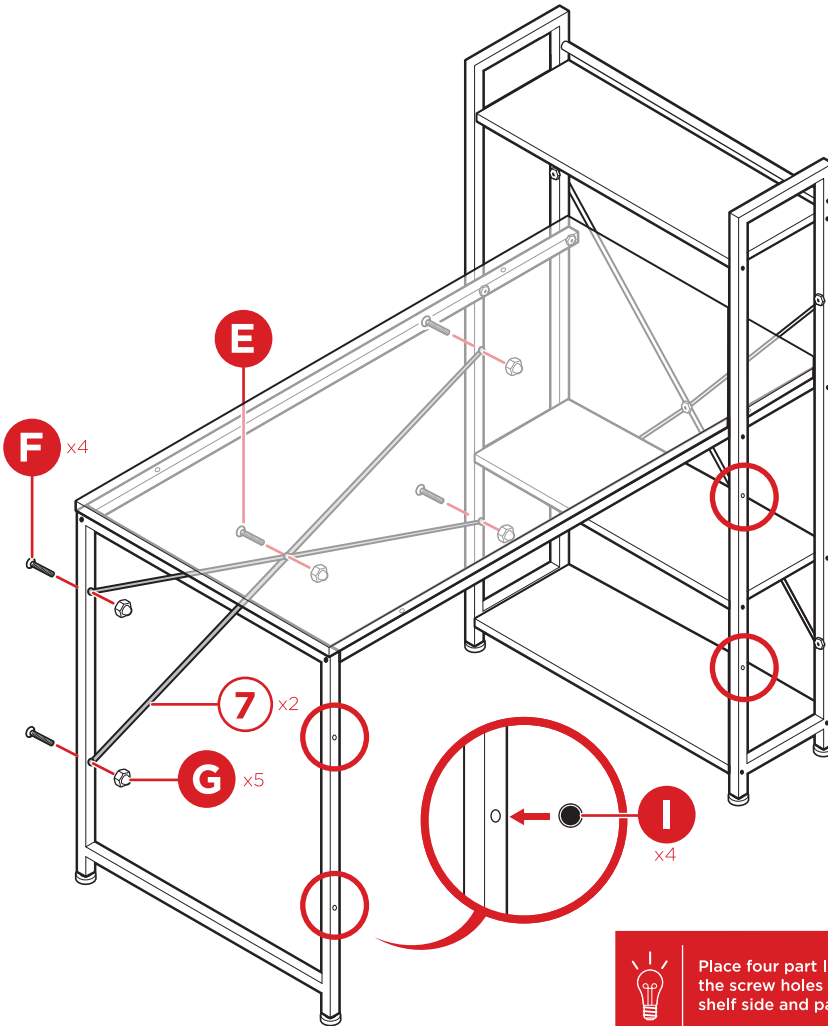

Place four part I stickers over the screw holes on the part 2 shelf side and part 4 table side.

BACK VIEW

Earn points while you shop. Join today!

bestchoiceproducts
rewards

Join | Earn | Redeem

Give your friends 15% off their first order! For each successful referral you'll receive 100 points.

bestchoiceproducts.com



HELP CENTER



Question about your product? We're here to help. Visit us at:

help.bestchoiceproducts.com



Chat Support



Product Inquiry



Orders FAQ



Product Assembly



Returns & Refunds

PRODUCT WARRANTY INFORMATION

All items can be returned for any reason within 60 days of the receipt and will receive a full refund as long as the item is returned in its original product packaging and all accessories from its original shipment are included. All returned items will receive a full refund back to the original payment method. All returned items will not be charged a re-stocking fee.

All returned items require an RA (Return Authorization) number, which can only be provided by a Best Choice Products Customer Service Representative when the return request is submitted. Items received without an RA may not be accepted or may increase your return processing time. Once an item has been received by Best Choice Products, refunds or replacements will be processed within 5 business days.

All returns must be shipped back to the Best Choice Products Return Center at the customer's expense. If the reason for return is a result of an error by Best Choice Products then Best Choice Products will provide a pre-paid shipping label via email. Boxes for return shipping will not be provided by Best Choice Products, and is the customer's responsibility to either use the original shipping boxes or purchase new boxes.

Pictures may be required for some returns to ensure an item is not damaged prior to its return. Items returned are not considered undamaged until they are received by Best Choice Products and verified as such. All damages to items are the customer's responsibility until the item has been received by and acknowledge by Best Choice Products as undamaged.

WARNING

Manufacturer and seller expressly disclaim any and all liability for personal injury, property damage or loss, whether direct, indirect, or incidental, resulting from the incorrect attachment, improper use, inadequate maintenance, or neglect of this product.