

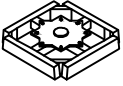

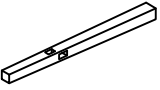

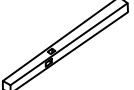

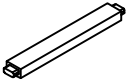



# ASSEMBLY INSTRUCTION

## SWIVEL COUNTER / BAR HEIGHT STOOL

<b>A</b> Chair Body 	<b>B</b> Seat Frame 	<b>C</b> Left Leg 	<b>D</b> Right Leg 
<b>E</b> Front / Rear Stretcher 	<b>F</b> Side Stretcher 	<b>G</b> Bolt Ø8x55mm 	<b>H</b> Bolt Ø6x25mm 
<b>I</b> Lock Washer Ø8x13mm 	<b>J</b> Flat Washer Ø8x22mm 	<b>K</b> Flat Washer Ø6x16mm 	<b>L</b> Lock Washer Ø6x11mm 
<b>M</b> Allen Key M5 	<b>N</b> Allen Key M4 	<b>O</b> Screw M4x45mm 	<b>P</b> Screwdriver (Not Provided) 
<b>1pc</b>	<b>1pc</b>	<b>8pcs</b>	<b>1pc</b>

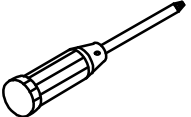
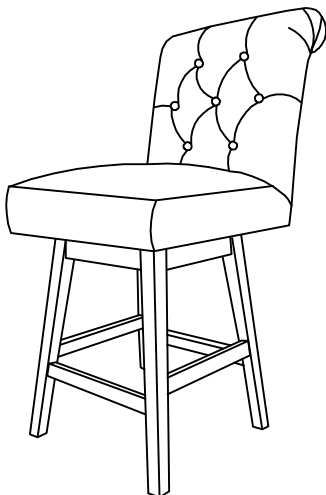

This page lists all the contents included in the box. Please take the time to identify the hardware as well as the individual components to this product. As you unpack and prepare for assembly, place the contents on a carpeted or padded area to protect them from damage.

- 1** First, attach Left Leg (C) & Right Leg (D) to Seat Frame (B), using Bolt (G), Lock Washer (I) and Flat Washer (J) on both holes of Seat Frame (B) by Allen Key (M). Turn the Allen Key (M) in Bolt (G). But not too tight. Second, attach Side Stretcher (F) to Left Leg (C) & Right Leg (D) as below shown. Third, attach Front / Rear Stretcher (E) to Left Leg (C) & Right Leg (D) as below shown.

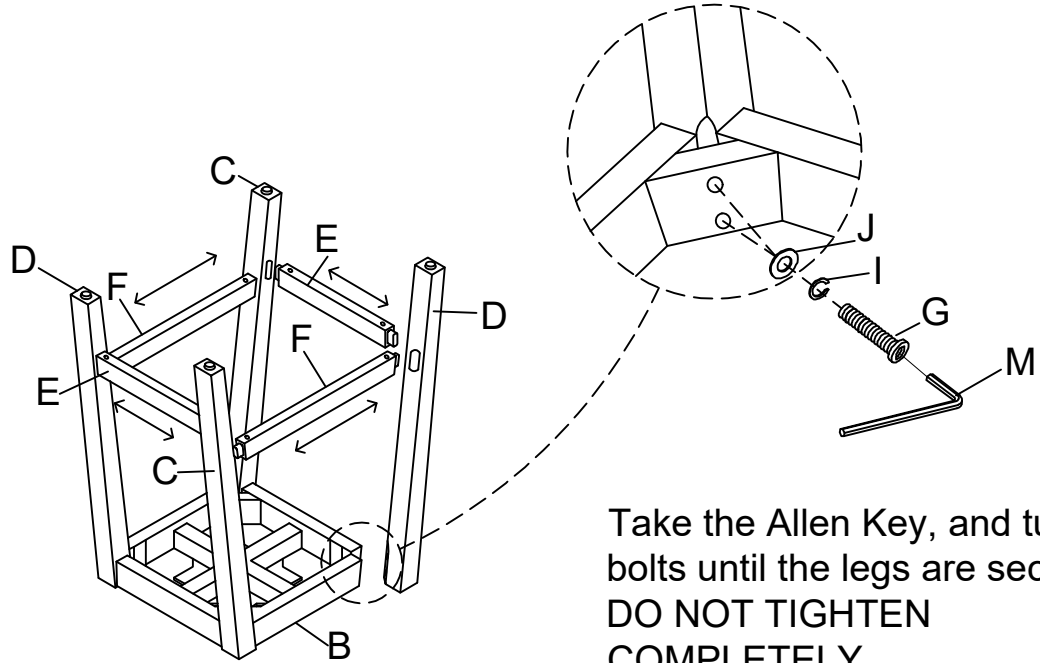

Take the Allen Key, and turn the bolts until the legs are secure. **DO NOT TIGHTEN COMPLETELY.** Stop when you feel you are adding force to tighten the bolt.

- 2** Secure the Front / Rear Stretcher (E) and Side Stretcher (F) with Left Leg (C) & Right Leg (D) using Screw (O) by Screwdriver (P) as below shown.

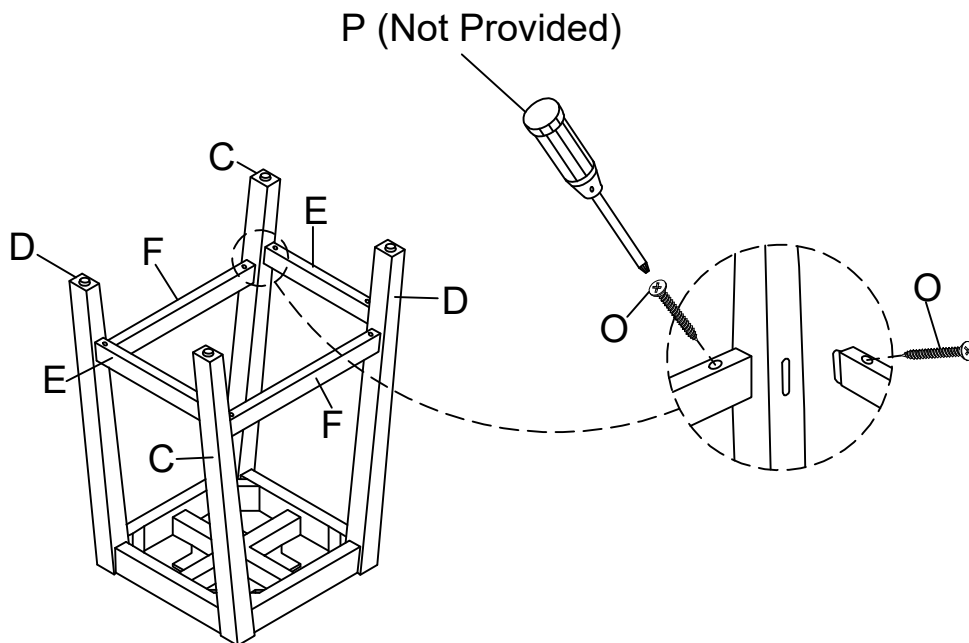

- 3** Attach pre-assembled Seat Frame (B) to Chair Body (A) using Bolt (H), Flat Washer (K) and Lock Washer (L) by Allen Key (N) as below shown.  
Tighten all bolts and finish the assembling.

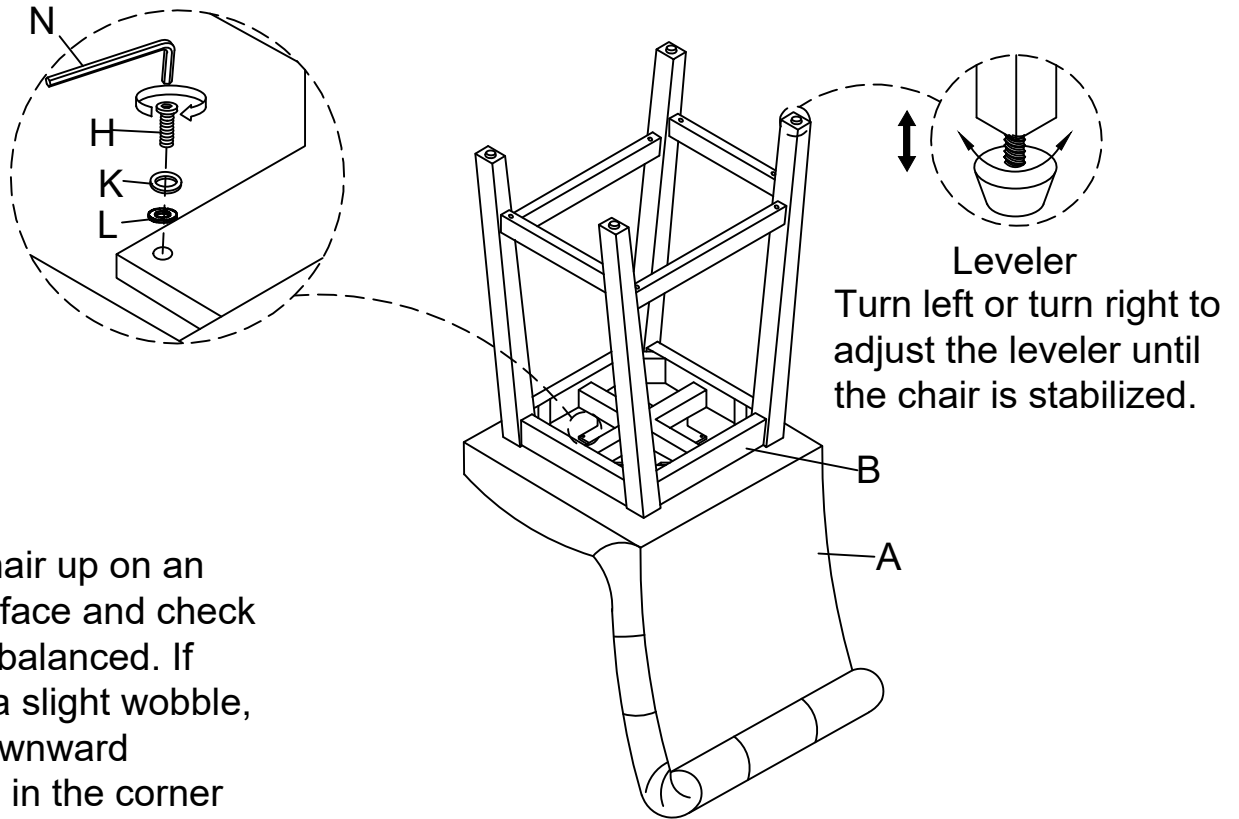

Stand chair up on an even surface and check that it is balanced. If there is a slight wobble, apply downward pressure in the corner where a leg is uneven. Keeping pressure in that corner, tighten all bolts. If balanced, apply downward pressure evenly in the center and tighten all bolts. Do not over-tighten beyond hole depth.

**Helpful Tip:**  
-Instead of applying downward pressure while reaching under to tighten bolts, have someone sit in the chair while you tighten the bolts.

### Cleaning & Care

Treat surface with care. Surface is resistant to scratches but is not scratch resistant. Clean surfaces with a dry or damp soft cloth. Do not use abrasive cleaners. Hardware may loosen over time. Periodically check that all connections are tight.