



ASSEMBLY INSTRUCTION FOR 26120 DINING TABLE

HARDWARE LIST

NO.	ITEM	DESCRIPTIN	QTY.
1		Bolt M8X35 MM	8
2		Flat washer M8X22 MM	8
3		Wrench	1

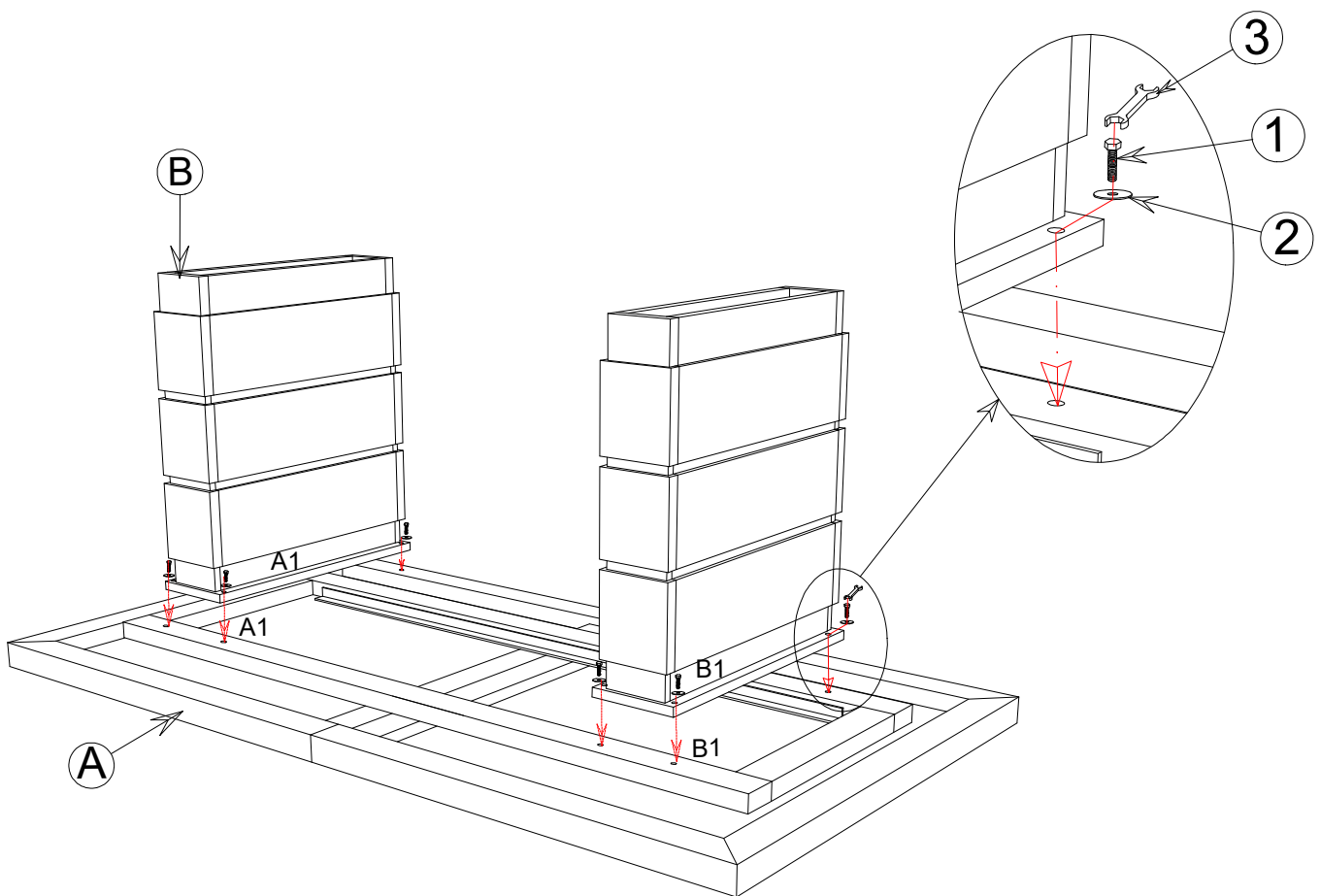
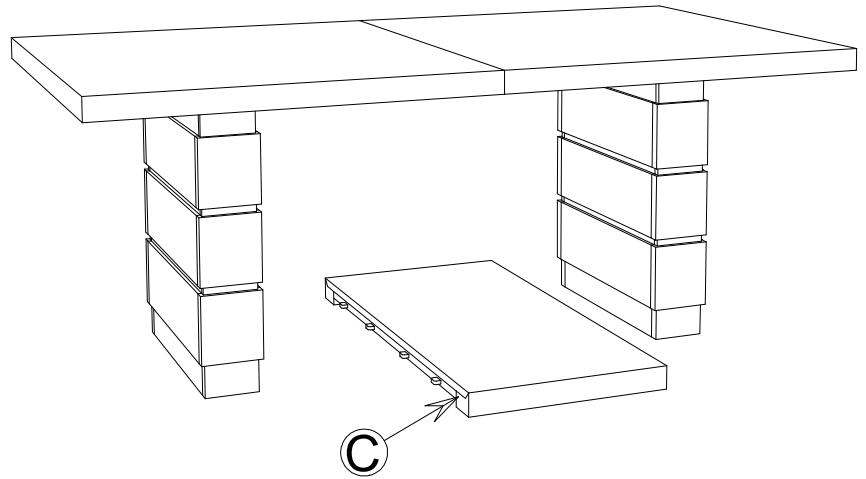

TO ASSEMBLY :

- STEP 1 : Unpack dining table and turn the top (A) upside down on a soft clean surface.
- STEP 2 : Align holes in legs (B) with holes on bottom of top (A) and slide it into position.
- STEP 3 : Assemble the Top(A) with Legs (B) matching the alphabets (A1-A1) & (B1-B1) .
- STEP 4 : Thread all the flat washer(2) , bolt (1) to leg (B) . When all the bolts are half tighten then follow steps 5.
- STEP 5 : Tighten all bolts fully with wrench (3) & (4) then carefully turn the dining table upright.

