





# HEKMAN

A HOWARD MILLER COMPANY

## ASSEMBLY INSTRUCTIONS

25864 HFR / 25865 HFR - Kingbed / Queenbed

| NO. | Hardware List   |                          | Q'ty |
|-----|---|--------------------------|------|
| A   |  | Double Thread M8 * 100mm | 8    |
| B   |  | Half Moon Washer         | 8    |
| C   |  | Nut M8                   | 8    |
| D   |  | Wrench 13mm              | 1    |
| E   |  | Screw 8 * 1 1/4"         | 8    |

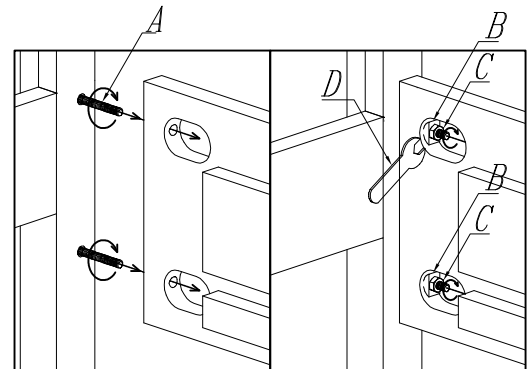

1

2

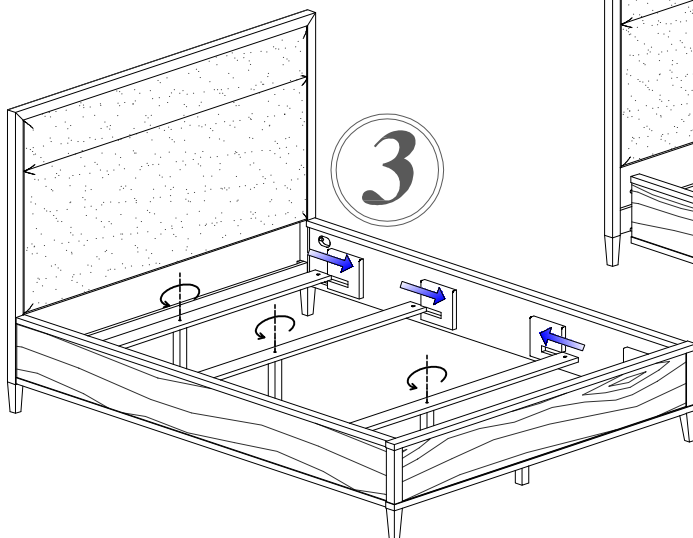

3

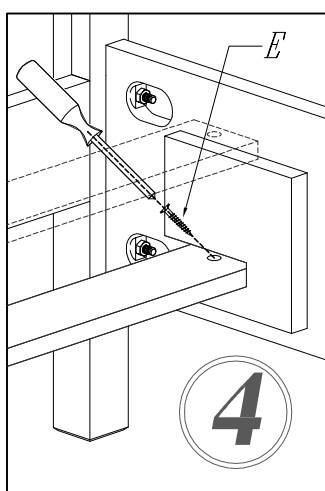
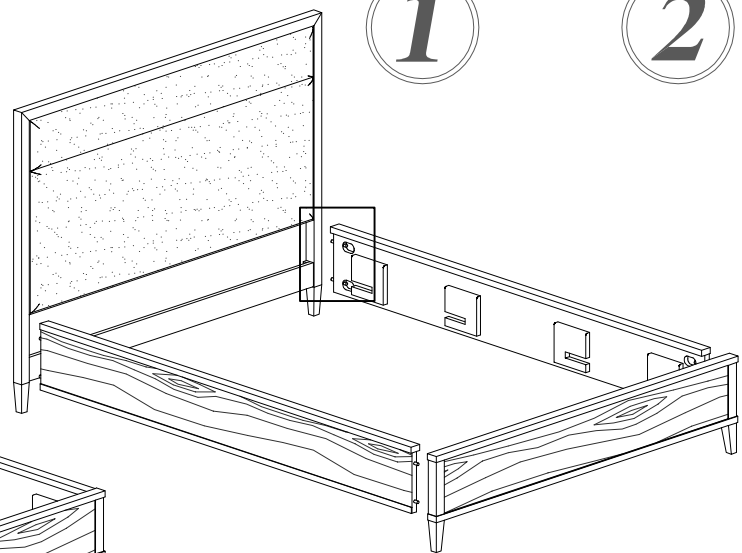

4

\* SCREW DRIVER  
NOT INCLUDED

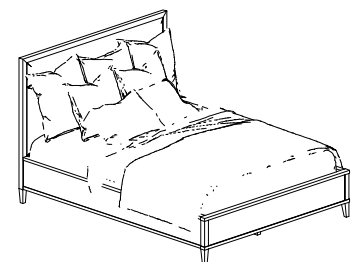

1. ASSEMBLY BED RAILS TO THE HEADBOARD AND FOOTBOARD WITH THREADED ROD (A), HALF MOON WASHER (B), AND NUT (C), TIGHTEN USING WRENCH (D)
2. ATTACH THE FEET TO BED SLATS USING LONG SEGMENTS FOR HIGHER POSITION, AND SHORT SEGMENT FOR LOWER POSITION
3. PLACE THE BED SLATS IN THE POSITION THE FEET ARE ADJUSTED FOR, AND ATTACH WITH SCREW (E)

MADE IN INDONESIA