

ASSEMBLY INSTRUCTION

DINING CHAIR

- | | | | |
|---------------------|--------------------|--------------------|-----------------------|
| A Back Frame | B Front Leg | C Side Rail | D Cushion Seat |
|---------------------|--------------------|--------------------|-----------------------|

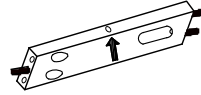
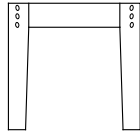
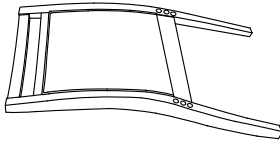

- | | | | |
|---------------------------------------|---------------------------------------|-------------------------------------|---|
| 1 pc E JCBC Bolt M6x60mm | 1 pc F JCBC Bolt M6x70mm | 2 pcs G Lock Washer M8 | 1 pc H Flat Washer M8x13mm |
|---------------------------------------|---------------------------------------|-------------------------------------|---|

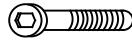
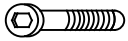

- | | | | |
|--|------------------------------------|-----------------------------------|-------|
| 2 pcs I Flat Washer M8x18mm | 4 pcs J Wood Screw M5 | 6 pcs K Allen Key M4 | 4 pcs |
|--|------------------------------------|-----------------------------------|-------|



- | | | |
|-------|-------|------|
| 2 pcs | 4 pcs | 1 pc |
|-------|-------|------|

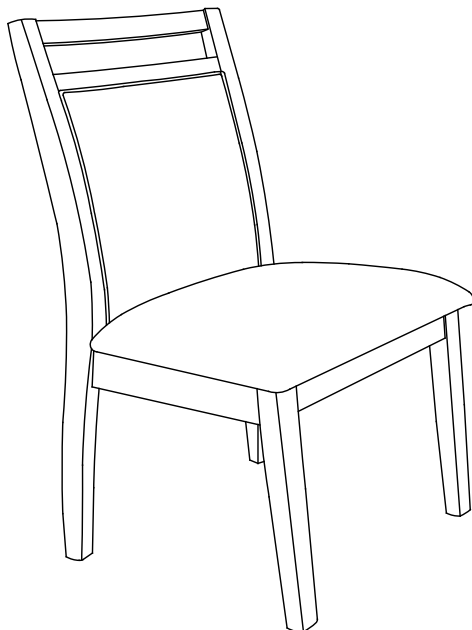

This page lists all the contents included in the box. Please take the time to identify the hardware as well as the individual components to this product. As you unpack and prepare for assembly, place the contents on a carpeted or padded area to protect them from damage.

1

Place the Front Leg (B) on the protective surface. Tighten the Front Leg (B) and Side Rail (C) by JCBC Bolt (E), Lock Washer (G), Flat Washer (I) and Allen Key (K).

**Do not fully tighten the bolt until all bolts are attached.

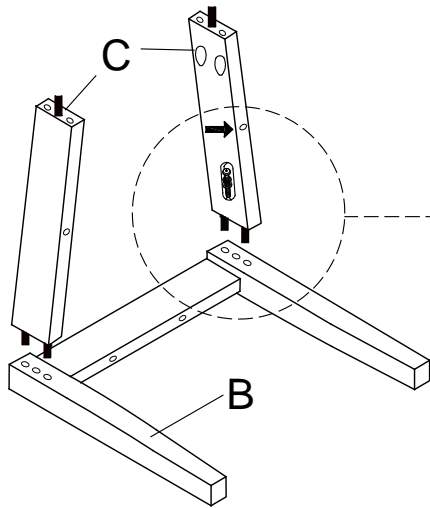

Take the Allen Wrench, and turn the bolts until the legs are secured.
DO NOT TIGHTEN COMPLETELY.
Stop when you feel you are adding force to tighten the bolt.

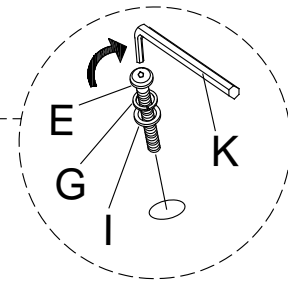
**2**

Place the Side Rail (C) on the Back Frame (A). Tighten the Side Rail (C) and the Back Frame (A) by JCBC Bolt (F), Lock Washer (G), Flat Washer (H) and Allen Key (K).

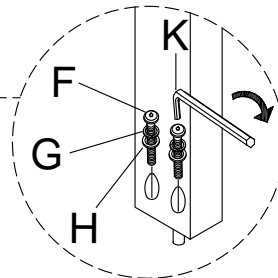
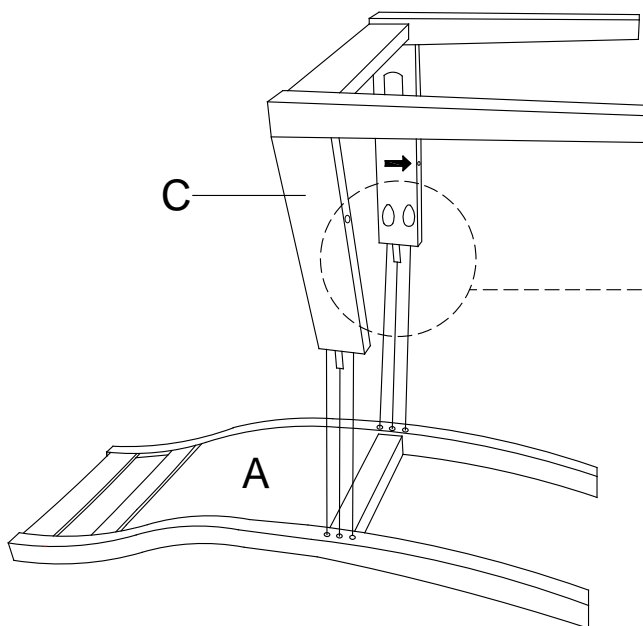

3

Place the Cushion Seat (D) on the Front Leg (B) and the Side Rail (C). Tighten the Cushion Seat (D), the Front Leg (B) and the Side Rail (C) by Wood Screw (J) and Screwdriver (not provided).

Stand chair up on an even surface and check that it is balanced. If there is a slight wobble, apply downward pressure in the corner where a leg is uneven. Keeping pressure in that corner, tighten all bolts. If balanced, apply downward pressure evenly in the center and tighten all bolts. Do not over-tighten beyond hole depth.

Helpful Tip:

-Instead of applying downward pressure while reaching under to tighten bolts, have someone sit in the chair while you tighten the bolts.

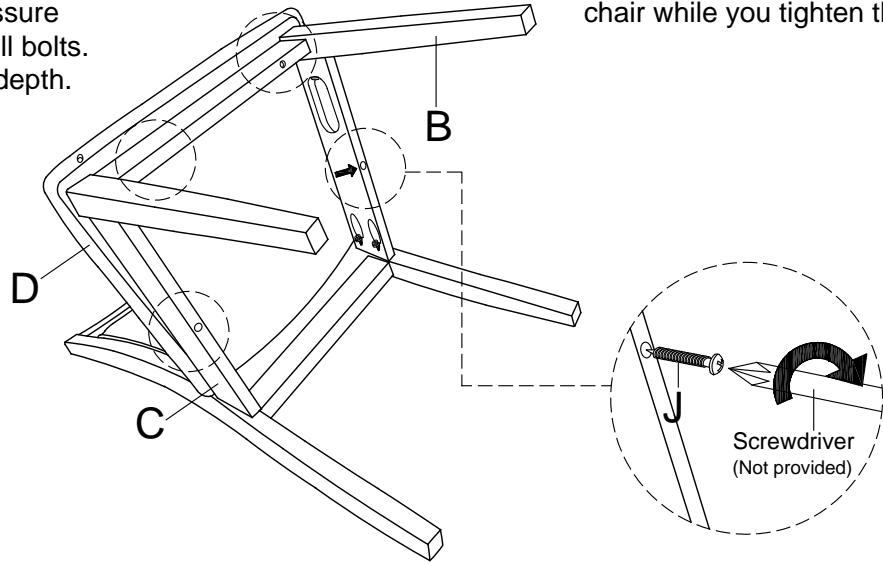
**4**

Stand chair up on an even surface and check that it is balanced.

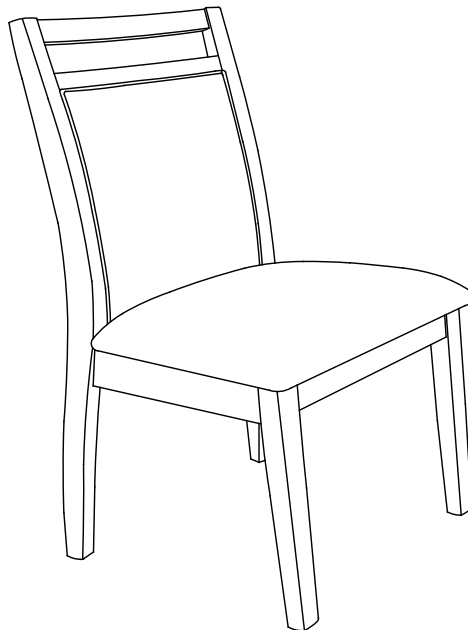

Cleaning & Care

Treat surface with care. Surface is resistant to scratches but is not scratch resistant. Clean surface with a dry or damp soft cloth. Do not use abrasive cleaners. Hardware may loosen over time. Periodically check that all connections are tight.