

# HOTLOK®



## HotLok® Pass Through Blanking Panels

### Part Numbers

1U - 10112

2U - 10113



1U Pass Through Blanking Panel - Part No. 10112



2U Pass Through Blanking Panel - Part No. 10113

### Applications

Designed to provide an effective airflow sealing solution when used in conjunction with pullout KVM switches or servers that may be occasionally extracted. Also provides additional rack sealing where cables prevent solid blanking panels from being installed.

This new aluminum and Hybrid Brush Technology panel cost effectively controls airflow and particulates for optimized cooling effectiveness. Lab tested HotLok Pass Through Blanking Panels also perform better than any competitive product. Available in both 1U and 2U configurations.

### Features

- Quick and secure installation procedure
- New Hybrid Brush Technology (HBT) allow cables to pass through securely without significant airflow leakage
- Fire resistant Aluminum frame gives additional rack rail support
- Engineered for standard EIA-310-E openings
- Available in 1U and 2U configurations

### Benefits

- Adds to overall aesthetics of the data center
- Easily pass cables from the front to the back of equipment while preventing re-circulation and bypass airflow
- Assists the flow of lower temperature conditioned air to the upper one-third of the cabinet, typically the hottest and most prone to equipment failure in the server rack area
- Use in a Hot and Cold Aisle containment configuration for low or high heat density cabinets
- Use in new or existing cabinets for rack configuration standardization

### Hybrid Brush Technology (HBT)

HBT is uniquely constructed to offer:

- Flexible and highly efficient sealing membrane
- Membrane supports bristles and limits leakage
- Multi-layered construction for increased sealing effectiveness
- Better overall sealing than traditional brush designs
- Significantly reduces re-circulation of hot exhaust air around cables, KVM switches or rack mount servers

## Specifications

Dimensions & Usable Area	Inches	Millimeters	Usable Area
Part No. 10112 - 1U - Overall size (length x height)	19" x 1.75"	482.5 x 44.45mm	11.5 sq. inches   282 sq. mm
Part No. 10113 - 2U - Overall size (length x height)	19" x 3.5"	482.5 x 89mm	42.75 sq. inches   1085 sq. mm

### Proven Rack Sealing System

HotLok Blanking Panels reduce hotspots and bypass airflow by preventing equipment exhaust air or hot aisle air from circulating to the conditioned air-intake stream at the front of the cabinet.

### Sealing Effectiveness

New, patented Hybrid Brush Technology (HBT) offers exceptional sealing and airflow management, unsurpassed by other leading brush products on the market today. Hybrid Brush Sealing Technology automatically seals around cables with no additional maintenance or monitoring required.

### 1U Product Image

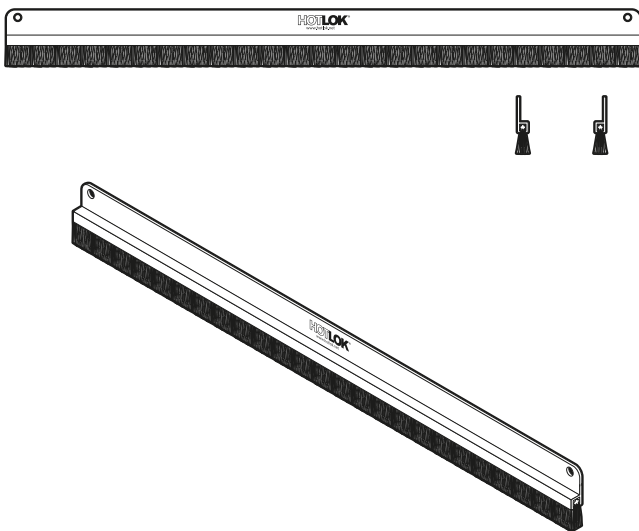

### Frame

Aluminum

### Color

Clear Anodized aluminum frame with black brushes

### Rack Mounting System

Removable clip and threaded bolt system ensures panel is firmly fastened to the rack. Designed to complement the HotLok Solid Blanking Panel ensuring a tight seal when placed between a pullout switch, server or tray.

### 2U Product Image

