

# BLACK DIAMOND®

Project Name: \_\_\_\_\_

Location: \_\_\_\_\_

Item #: \_\_\_\_\_

Qty: \_\_\_\_\_

## Black Diamond 2 Glass Door Reach-In Freezer 46.7 Cu. Ft. Capacity, in Stainless Steel

### USFZ-2D-G



The Black Diamond 2 Glass Door Reach-In Freezer delivers a generous 48 Cu. Ft. frozen storage capacity for food and ingredients with convenient visibility through two self-closing glass doors. Its heavy-duty stainless steel construction ensures longevity and easy maintenance, while a bottom-mounted compressor maximizes energy efficiency and performance. The electronic temperature control maintains ideal, food-safe temperatures between -8° and 0°F. Six adjustable, plastic-coated wire shelves provide flexible organization for commercial kitchens, bakeries, catering, and grocery stores. Equipped with automatic defrost and four 4" casters for mobility, this freezer simplifies cleaning and service access.

### FEATURES AND CONSTRUCTION

- Provides a large 46.7 Cu. Ft. frozen storage capacity for bulk food and ingredients
- Bottom-mounted 1.25 HP compressor delivers efficient cooling and is easily accessible for maintenance
- Constructed of heavy-duty stainless steel throughout the interior and exterior
- Temperature range from -8° to 0°F supports optimal food safety for diverse frozen products
- Two self-closing glass French doors with integrated handles enable clear visibility and easy access
- Six removable, plastic-coated wire shelves provide flexible organization for all frozen inventory
- Equipped with four 4" swivel casters for smooth mobility and cleaning access
- Removable door gasket
- Equipped with (4) 4" casters for easy mobility

### ELECTRIC

115V / 60Hz / 1Ph

Cord Length (Inches): 98.40"

Plug Type: NEMA 5-15P

Cord set included

NEMA 5-15P



### 3RD PARTY APPROVALS



### WARRANTY (USA / CANADA)

Two (2) Year Limited Warranty on Parts and Labor, Five (5) Year Warranty on Compressor and Evaporator

Contact us for details at 1.877.368.2797



### STORAGE CAPACITY

- Cubic Feet: 46.7 Cu. Ft.

### TEMPERATURE

- Holding Temperature (Fahrenheit): -8° - 0°

These models are designed to operate in an environment where temperature and humidity do not exceed 75°F (24°C) and 55% relative humidity



# Black Diamond 2 Glass Door Reach-In Freezer

USFZ-2D-G

FRONT

SIDE

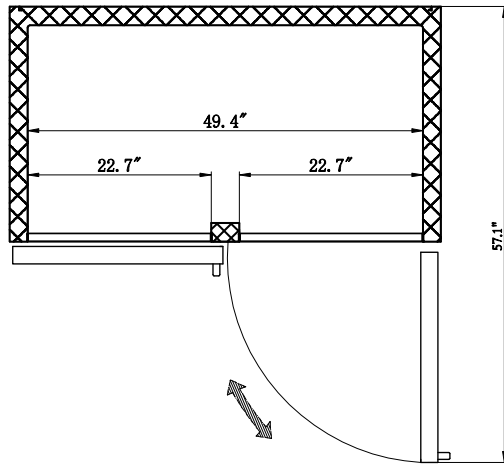
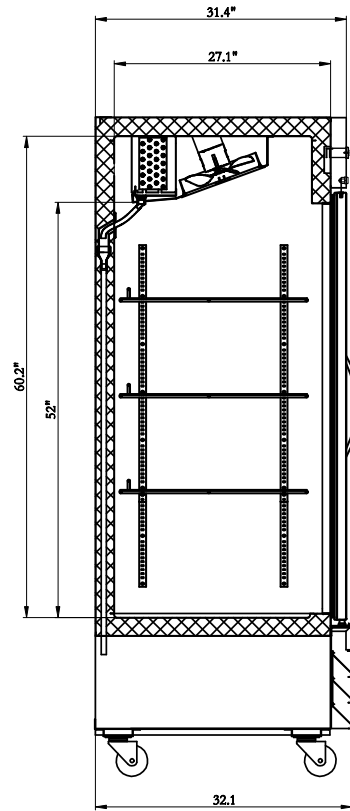
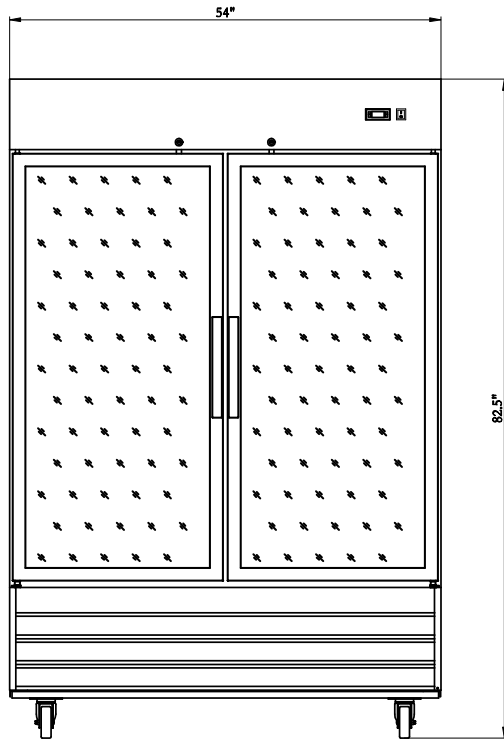

TOP

## Reach-In

Doors	Shelves	Amps	HP	Refrigerant	Assembled Dimensions (in)	Item Weight (lbs)	Shipping Weight (lbs)
2	6	10.7A	1.25	R290 4.942	54.00" x 32.20" x 82.50"	447.0	530.0

Due to periodic changes in designs, methods, procedures, policies and regulations, the specifications contained in this document are subject to change without notice. While we exercise good faith efforts to provide information that is accurate, we are not responsible for errors or omissions in information provided or conclusions reached as a result of using the specifications. By using the information provided, the user assumes all risks in connection with such use.