

INSTALLATION INSTRUCTIONS FOR OPTIMA® SYSTEMS SENSOR ACTIVATED ROYAL®, SLOAN®, and CROWN® FLUSHOMETERS WITH SMALL WALL BOX for CONCEALED CLOSET and URINAL INSTALLATIONS



Concealed Closet Flushometer with Small Wall Box

1½" Exposed Back Spud

- Model 140 SWB-ES-S

1½" Exposed Top Spud

- Model 142 SWB-ES-S

- Model 153 SWB-ES-S

1½" Concealed Back Spud

- Model 152 SWB-ES-S

Concealed Urinal Flushometer with Small Wall Box

1¼" Concealed Back Spud

- Model 190 SWB-ES-S

1¼" Exposed Top Spud

- Model 192 SWB-ES-S

¾" Concealed Back Spud

- Model 195 SWB-ES-S

¾" Exposed Top Spud

- Model 197 SWB-ES-S

LIMITED WARRANTY

Sloan Valve Company warrants its ES-S Sensor Activated Small Wall Box Flushometers to be made of first class materials, free from defects of material or workmanship under normal use and to perform the service for which they are intended in a thoroughly reliable and efficient manner when properly installed and serviced, for a period of three (3) years (1 year for special finishes) from date of purchase. During this period, Sloan Valve Company will, at its option, repair or replace any part or parts which prove to be thus defective if returned to Sloan Valve Company, at customer's cost, and this shall be the sole remedy available under this warranty. No claims will be allowed for labor, transportation or other incidental costs. This warranty extends only to persons or organizations who purchase Sloan Valve Company's products directly from Sloan Valve Company for purpose of resale.

THERE ARE NO WARRANTIES WHICH EXTEND BEYOND THE DESCRIPTION ON THE FACE HEREOF. IN NO EVENT IS SLOAN VALVE COMPANY RESPONSIBLE FOR ANY CONSEQUENTIAL DAMAGES OF ANY MEASURE WHATSOEVER.

VALVE ROUGH-IN

MODEL 140 SWB-ES-S

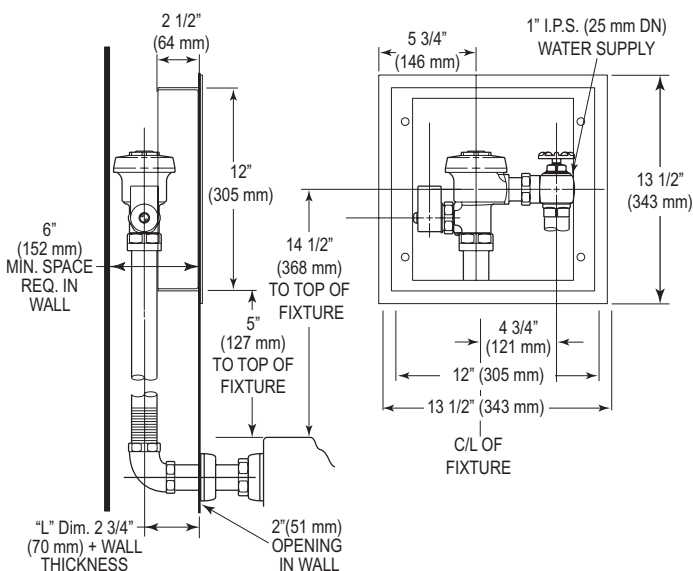

MODEL 142 SWB-ES-S

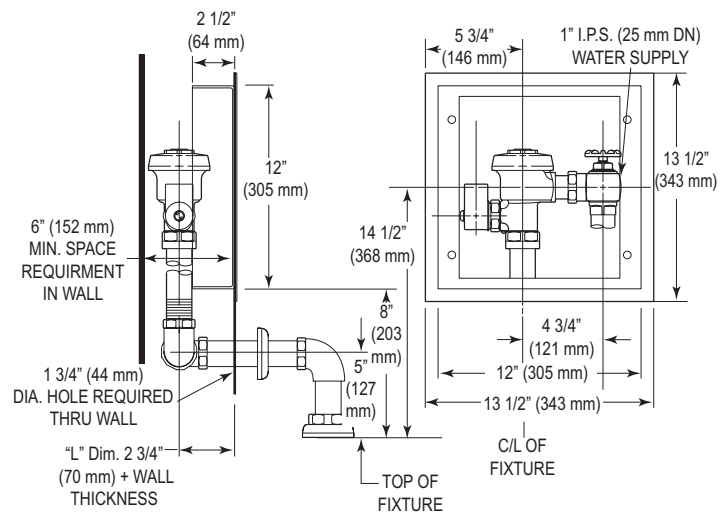

VALVE ROUGH-IN (Continued)

MODEL 152 SWB-ES-S

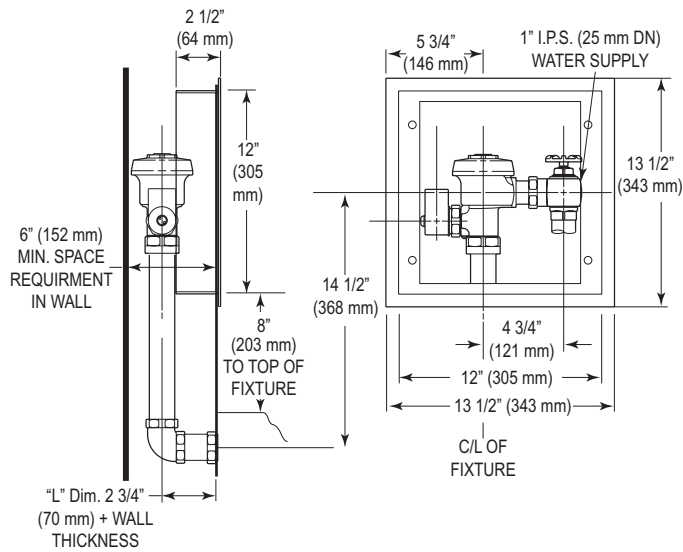

MODEL 153 SWB-ES-S

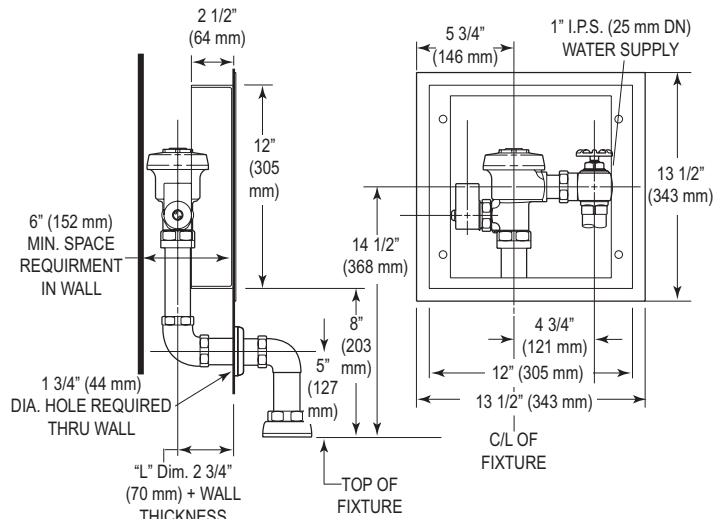

MODEL 190 SWB-ES-S

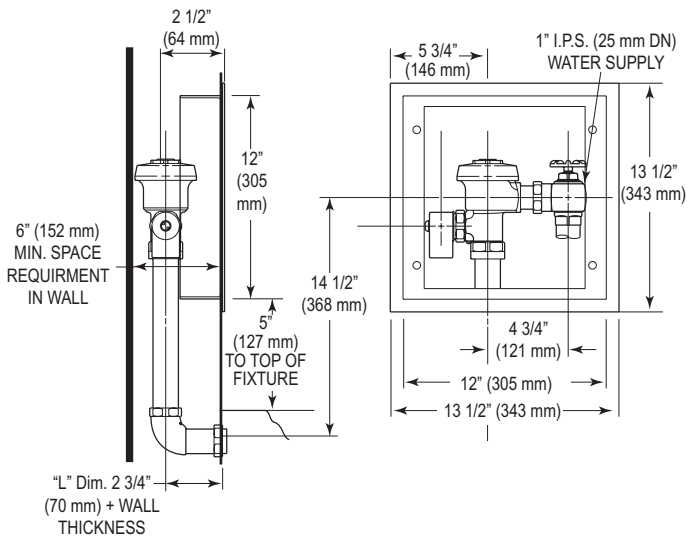

MODEL 192 SWB-ES-S

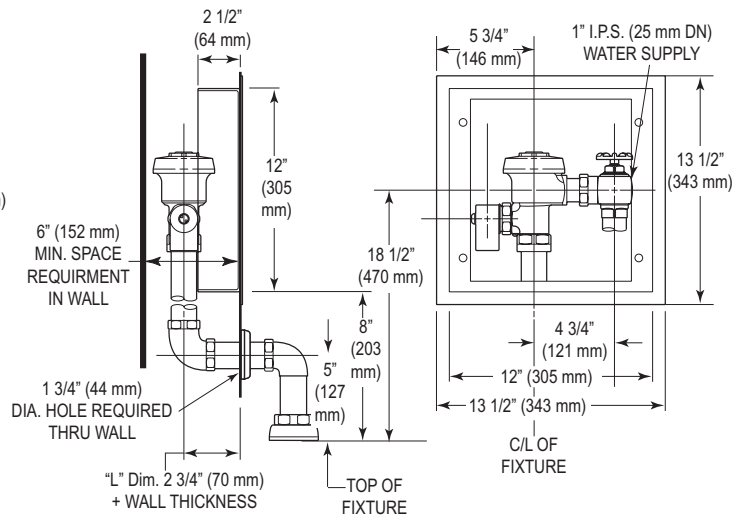

MODEL 195 SWB-ES-S

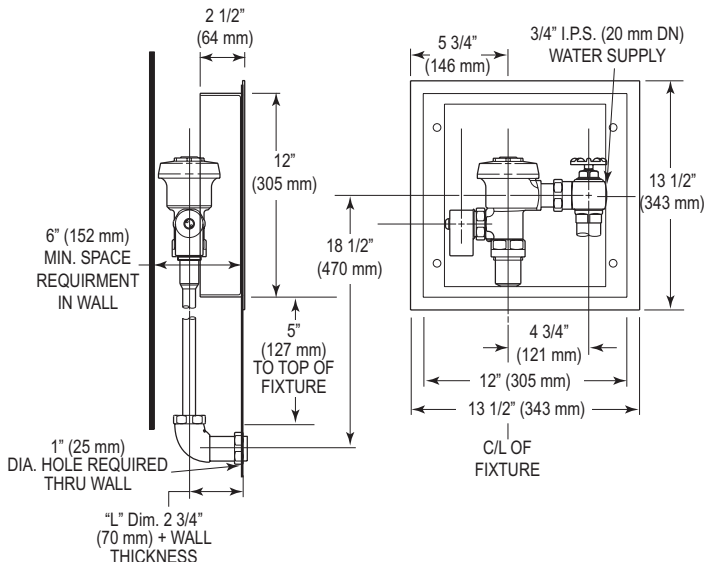

MODEL 197 SWB-ES-S

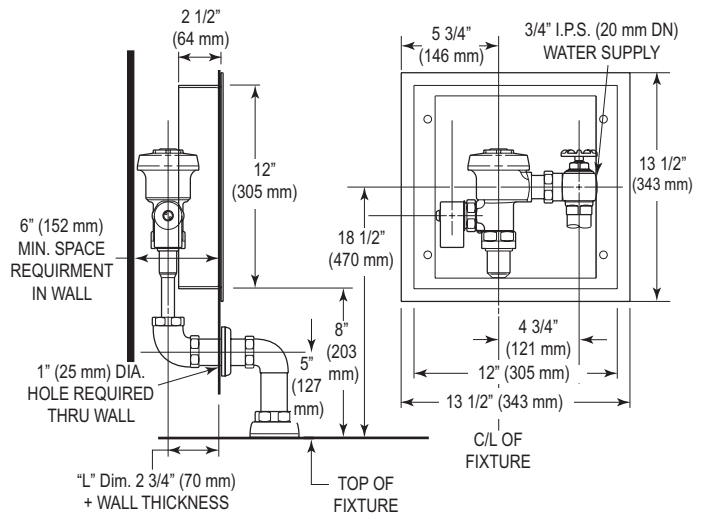

SMALL WALL BOX/SENSOR LOCATION & POSITIONING IS CRITICAL!

Failure to properly position the small wall box/sensor to the plumbing rough-in will result in improper installation and impair product performance. All tradesmen (plumbers, electricians, tile setters, etc.) involved with the installation of this product must coordinate their work to assure proper product installation.

PRIOR TO INSTALLATION

Check to make certain that "L" dimension shown on the Flushometer package is correct for your application (Lengths of 2" up to 10¾"). Determine the "L" dimension for your application by using the following formula:

$$\text{"L" dimension} = \text{Wall Thickness (To Nearest Whole Inch)} + 2\text{-}3/4\text{"}$$

Prior to installing the Sloan OPTIMA equipped Flushometer with Small Wall Box, install the items listed below. Refer to Rough-ins on the front page and page 2.

- 2-gang electrical box — 4" x 4" x 2-1/2" (102 mm x 102 mm x 64 mm) for transformer; see paragraph entitled "Transformer Installation"
- Electrical wiring to the transformer box (120 VAC, 2 amp service required for each EL-154, 24 VAC, 50 VA transformer used)
- Closet or urinal fixture
 - Drain line
- Water supply line

Important:

- INSTALL ALL ELECTRICAL WIRING IN ACCORDANCE WITH NATIONAL/ LOCAL CODES AND REGULATIONS.
- INSTALL ALL PLUMBING IN ACCORDANCE WITH APPLICABLE CODES AND REGULATIONS.
- WATER SUPPLY LINES MUST BE SIZED TO PROVIDE AN ADEQUATE VOLUME OF WATER FOR EACH FIXTURE.
- A 24 VAC STEP-DOWN TRANSFORMER MUST BE USED.
- USE APPROPRIATE PRECAUTIONS WHILE CONNECTING TRANSFORMER TO 120 VAC POWER SOURCE.
- FLUSH ALL WATER LINES PRIOR TO MAKING CONNECTIONS.

Royal®, Sloan®, and Crown® Flushometers are designed to operate with 15 to 100 psi (104 to 689 kPa) of water pressure. THE MINIMUM PRESSURE REQUIRED TO THE VALVE IS DETERMINED BY THE TYPE OF FIXTURE SELECTED. Consult fixture manufacturer for minimum pressure requirements. Most Low Consumption water closets (1.6 gallon/6.0 liter) require a minimum flowing pressure of 25 psi (172 kPa).

Protect the Chrome or Special finish of the Flushometer — DO NOT USE TOOTHED TOOLS TO INSTALL OR SERVICE THE VALVE. Also, see "Care and Cleaning" section of this manual. Important: EXCEPT FOR CONTROL STOP INLET, DO NOT USE PIPE SEALANT OR PLUMBING GREASE ON ANY VALVE COMPONENT OR COUPLING!

!!! IMPORTANT !!!

With the exception of Control Stop Inlet, DO NOT use pipe sealant or plumbing grease on any valve component or coupling!

!!! IMPORTANT !!!

This product contains mechanical and/or electrical components that are subject to normal wear. These components should be checked on a regular basis and replaced as needed to maintain the valve's performance.

Transformer Installation

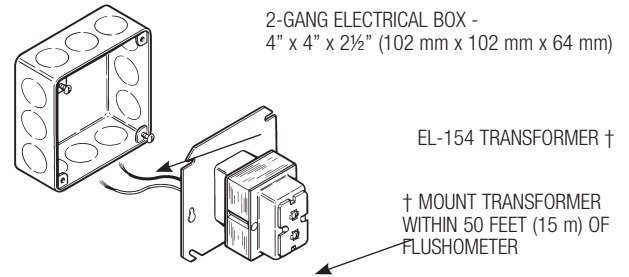

Install Transformer (EL-154) on a 2-Gang Electrical Box, 4" x 4" x 2-1/2" (102 mm x 102 mm x 64 mm) in a convenient location; refer to the illustration below. Note: One Sloan EL-154 transformer (Class 2, UL Listed, 50 VA (min.) at 24 VAC) can operate up to ten OPTIMA equipped Flushometers. Run 18-gauge wire from transformer to Flushometer(s). Wire supplied by others. DO NOT supply power to transformer until installation of Flushometer is complete.

Small Wall Box/Sensor Location

SMALL WALL BOX/SENSOR LOCATION IS CRITICAL — Failure to properly position the Wall Box to the plumbing rough-in will result in improper installation and impair product performance. All tradesmen (plumbers, electricians, tile setters, etc.) involved with the installation of this sensor activated flushometer must be familiar with the requirements of its installation. Improper installation may void the manufacturer's warranty.

Tools Required for Installation

- Slotted and Phillips screwdrivers
- 5/64" hex wrench (supplied)
- Wrench for tamper resistant screws (supplied)
- Sloan A-50 Super-Wrench™ or smooth jawed spud wrench
- Channel lock® plier or adjustable wrench
- Wire stripper/crimping tool

!!! IMPORTANT !!!

Protect the chrome or special finish of Sloan Flushometers — DO NOT USE toothed tools to install or service these valves. Use a Sloan A-50 Super-Wrench™, Sloan A-109 Plier Wrench or smooth jawed spud wrench to secure all couplings. Also see "Care and Cleaning" section of this manual.

!!! IMPORTANT !!!

Never open Control Stop to where the flow from the valve exceeds the flow capability of the fixture. In the event of a valve failure, the fixture must be able to accommodate a continuous flow from the valve.

1 - INSTALL WALL BOX INTO WALL AND INSTALL OPTIONAL SWEAT SOLDER ADAPTER (only if your supply pipe does not have a male thread)

- A** Install Wall Box flush with Wall. Secure using Fasteners. Note: Fasteners supplied by installer.

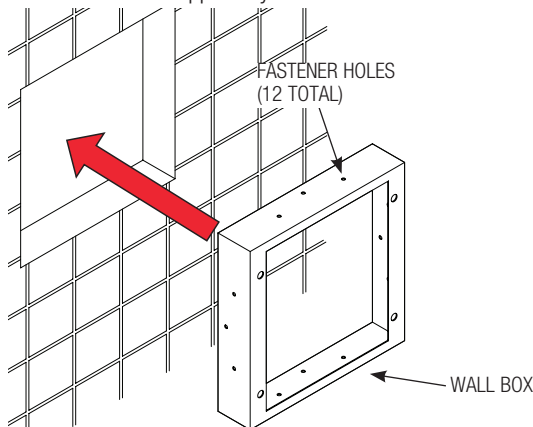

- B** Slide Threaded Adapter fully onto pipe.

- C** Sweat solder the Adapter to pipe.

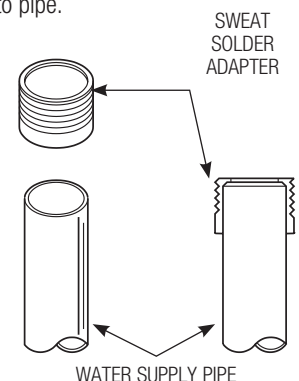

2 - INSTALL CONTROL STOP TO SUPPLY PIPE

- A** Thread Control Stop onto water supply line. Tighten with a wrench making sure outlet is positioned as required.

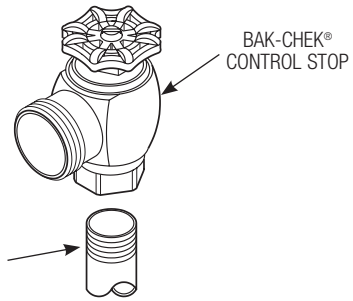

!!! IMPORTANT !!!
With the exception of Control Stop Inlet, DO NOT use pipe sealant or plumbing grease on any valve component or coupling!

3 - INSTALL VACUUM BREAKER FLUSH CONNECTION

- A** Assemble Pipe, Elbows, Couplings, Nylon Slip Gasket, Rubber Gaskets and Flanges as illustrated.
- B** Insert Tube into Fixture Spud.
- C** Hand tighten all Couplings.

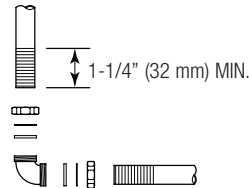

IMPORTANT: WHEN CUTTING SCORED PIPE TO LENGTH LEAVE A MINIMUM OF 1-1/4" (32 mm) OF SCORING TO ENSURE PROPER ENGAGEMENT

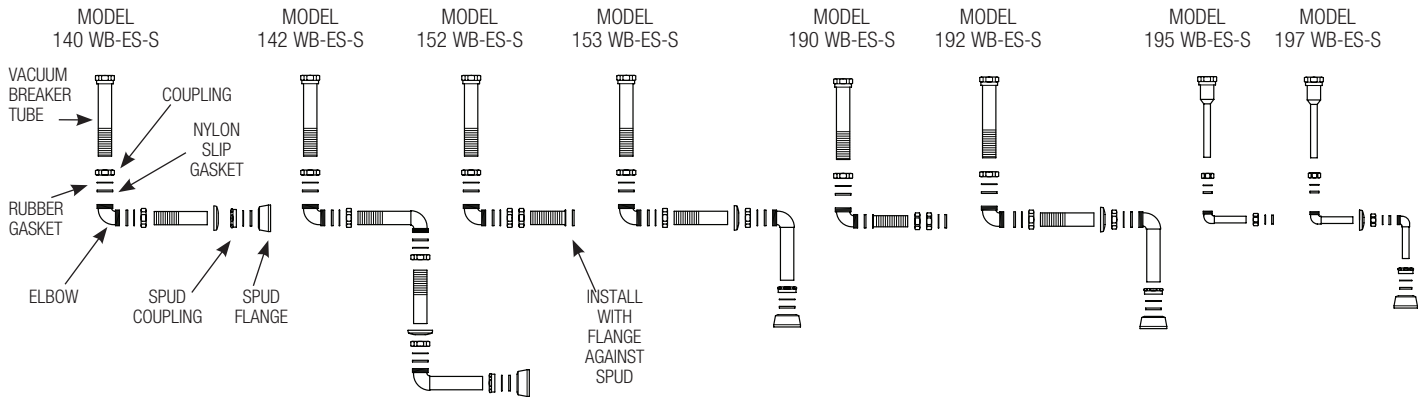

4 - INSTALL FLUSHOMETER

NOTE
For high efficiency urinal flushometers (0.5, 0.25 and 0.125 gpf), it is necessary to first insert the flow control component into the tailpiece assembly. See the H1015A flow control kit and separate instructions for details on how to install.

- A** Lubricate tailpiece O-ring with water. Insert Adjustable Tailpiece into Control Stop. Tighten Tailpiece Coupling by hand.
- B** Align Flushometer directly above the Vacuum Breaker Flush Connection by sliding the Flushometer Body IN or OUT as needed. Tighten Vacuum Breaker Coupling by hand.
- C** Align Flushometer Body and securely tighten first the Tailpiece Coupling (1), then the Vacuum Breaker and Pipe Couplings (2), and finally the Spud Coupling (3). Use a wrench to tighten these couplings in the order shown.

NOTE
Max. adjustment of Sloan Adjustable Tailpiece is 1/2" (13 mm) IN or OUT from the standard 4 3/4" (121 mm) (c/l of Valve to c/l of Control Stop).
If roughing-in measurement exceeds 5 1/4" (133 mm), consult factory for longer tailpiece.

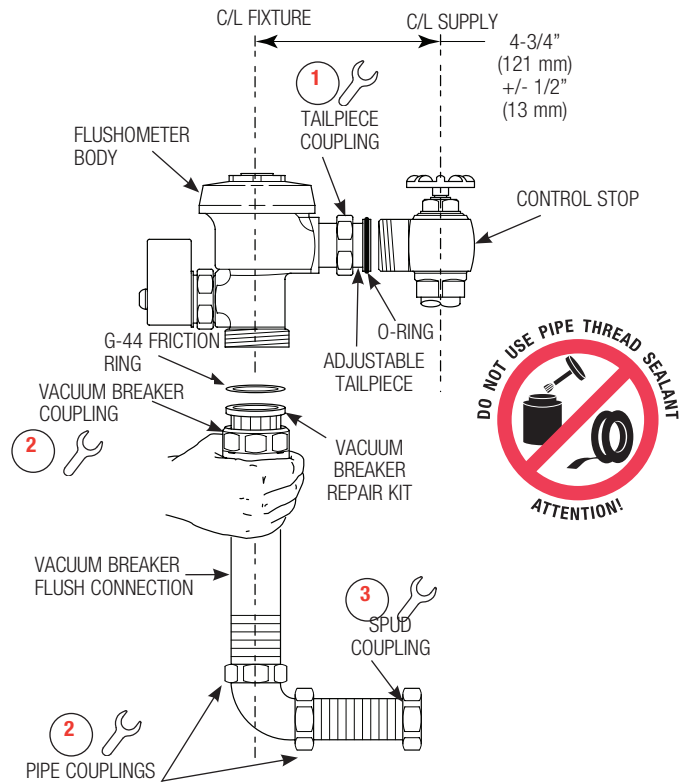

5 - INSTALL U-TYPE NUTS ONTO FRAME AND CONNECT ELECTRICAL COMPONENTS

- A** Slide four (4) U-type Nuts onto frame at each hole location as shown.

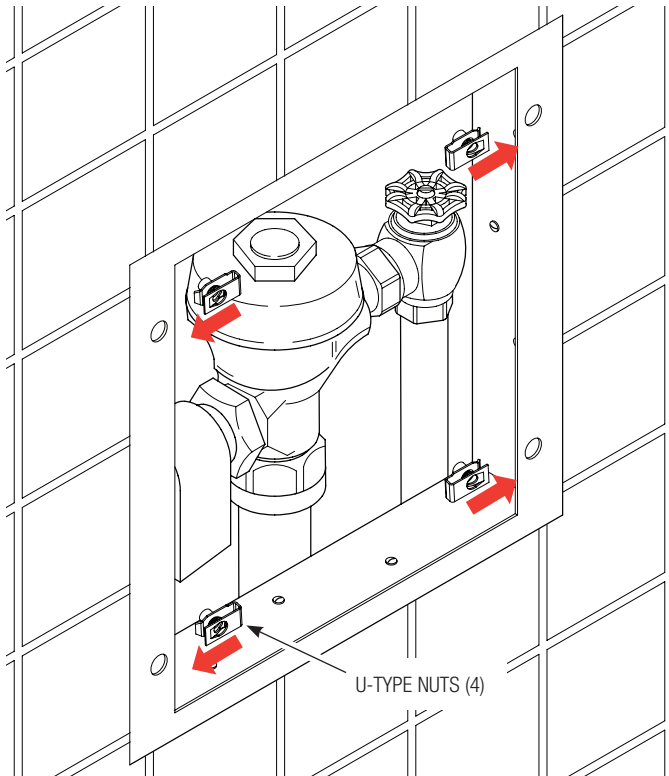

- B** Be certain power is OFF to prevent damage to electrical components. Connect wires EXACTLY as instructed and shown.
- C** On the wall plate assembly, connect the two YELLOW wires from the Circuit Board to the Override Button.
- D** Connect the two RED wires from the Circuit Board to the Sensor.

- E** Connect the two BLACK wires from the Circuit Board to the Solenoid wires using wire nuts (supplied by others).
- F** Connect the two wires from the Transformer to the BLUE Terminal Block.

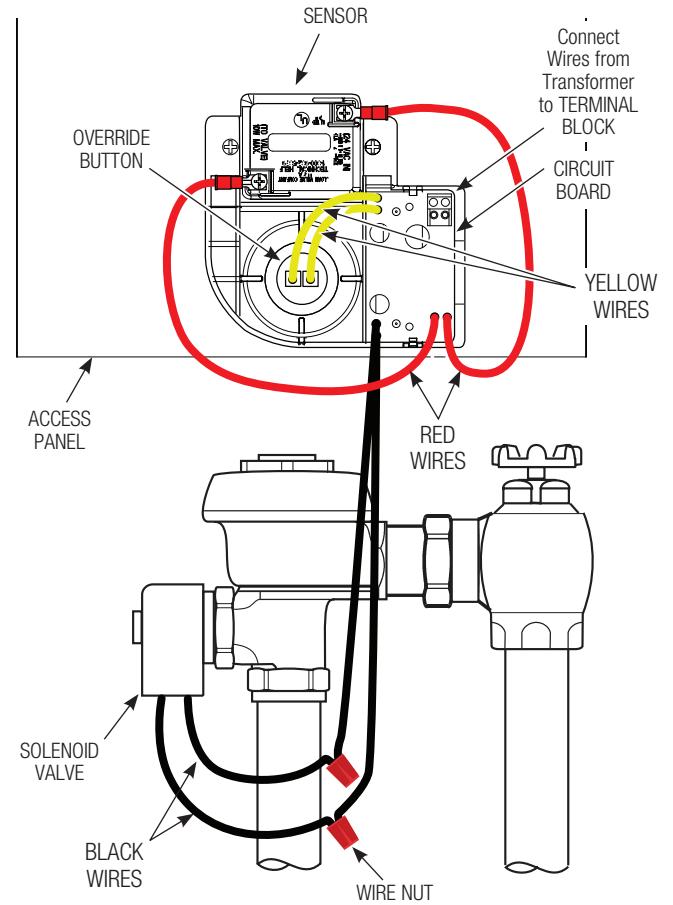

6 - FLUSH OUT SUPPLY LINE

- A** Make sure Control Stop is CLOSED.

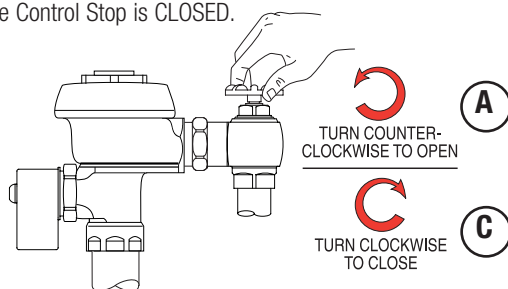

- B** Remove Flushometer Cover and lift out Inside Parts Assembly. Reinstall Flushometer Cover wrench tight.
- C** Open Control Stop. Turn on water supply to flush line of any debris or sediment.
- D** Shut off Control Stop, remove Cover and reinstall Inside Parts Assembly. Install Flushometer Cover wrench tight. Do Not Open Control Stop until Step 7.

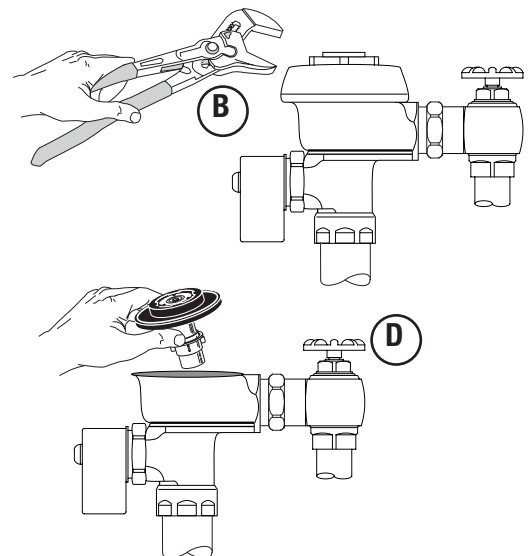

7 - TURN WATER ON AND ADJUST CONTROL STOP

- A** Adjust Control Stop to meet the flow rate required for proper cleansing of the fixture. Open Control Stop COUNTERCLOCKWISE 1/2 turn from the closed position.

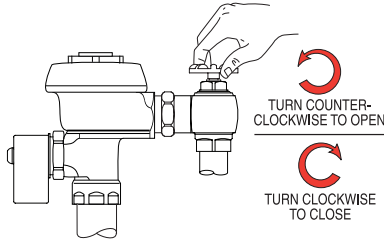

- B** Activate Flushometer by placing hand in front of OPTIMA Sensor Lens for ten (10) seconds and then moving it away.

- C** Adjust Control Stop after each flush until the rate of flow delivered properly cleanses the fixture.

!!! IMPORTANT !!!

All Sloan® Flushometers are engineered for quiet operation. Excessive water flow creates noise, while too little water flow may not satisfy the needs of the fixture. Proper adjustment is made when plumbing fixture is cleansed after each flush without splashing water out from the lip AND a quiet flushing cycle is achieved.

Never open Control Stop to where the flow from the valve exceeds the flow capability of the fixture. In the event of a valve failure, the fixture must be able to accommodate a continuous flow from the valve.

8 - INSTALL ACCESS PANEL AND TEST SENSOR OPERATION

- A** Slide access panel over the wall box aligning the four (4) mounting holes.

- B** Install the four (4) fasteners into the four (4) mounting holes.

- C** Turn the power ON.

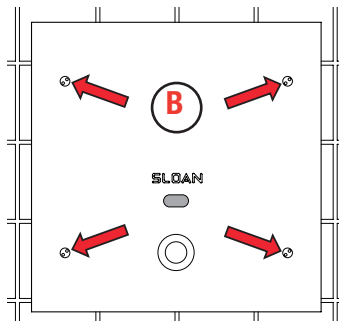

- D** For the first ten (10) minutes of operation, a Visible Light flashes in the Sensing Window of the Flushometer when a user is detected.

- E** Stand in front of Sensor for sixteen (16) seconds for closet/eight (8) seconds for urinal.

- F** Step away from Sensor and listen for "CLICK."

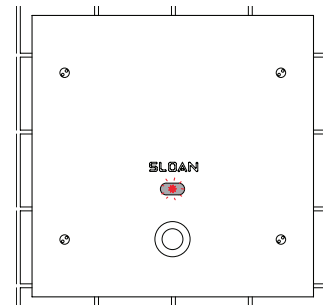

NOTE

The factory setting should be satisfactory for most installations.

The Optima® sensor has a factory set sensing range:
Water Closets: 22" to 42" (559 mm to 1067 mm)
Urinals: 15" to 30" (381 mm to 762 mm)

OPERATION

1. A continuous, invisible light beam is emitted from the OPTIMA Sensor.

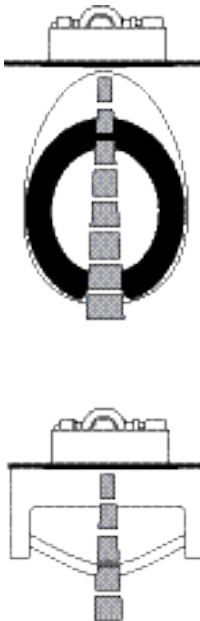

2. When a user enters the beam's effective range, for water closets 22" - 42" (559 mm - 1067 mm) and for urinals 15" - 30" (381 mm - 762 mm), the beam is reflected into the OPTIMA's scanning window and transformed into a low voltage electrical signal that activates a sixteen (16) second (closet) /eight (8) second (urinal) time delay circuit. The time delay circuit eliminates false operation from passers-by in the rest room. Once the time delay is completed, the output circuit is alerted and continues in a "hold" mode for as long as the user remains within the effective range of the sensor.

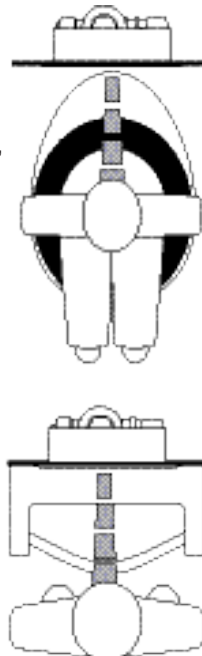

3. When the user steps away from the OPTIMA Sensor, the loss of reflected light initiates an electrical "one-time" signal that energizes the Solenoid Operator, and activates the Flushometer to flush the fixture. This occurs on the water closet approximately three (3) seconds after indication. This delay is built into the Sensor to help prevent false flushing due to movement by the user. The circuit for both water closets and urinals then automatically resets and is ready for the next user.



CARE AND CLEANING

DO NOT use abrasive or chemical cleaners (including chlorine bleach) to clean Flushometers as they may dull the luster and attack the chrome or special decorative finishes. Use ONLY soap and water, then wipe dry with clean cloth or towel.

While cleaning the bathroom tile, the Flushometer should be protected from any splattering of cleaner. Acids and cleaning fluids can discolor or remove chrome plating.

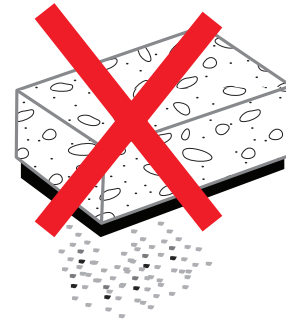

TROUBLESHOOTING GUIDE

NOTE: Upon detection of the user, the red indicator light flashes slowly for a period of eight seconds. When the user leaves the detection range, the indicator light flashes rapidly and the Sensor initiates the flush sequence. Then the indicator light stops flashing and the valve flushes. The valve will flush after a three-second delay.

1. **PROBLEM:** Valve does not function (red light does not flash when user steps in front of sensor).
CAUSE: No power is being supplied to sensor.
SOLUTION: Ensure that the main power is turned "ON." Check transformer, leads and connections. Repair or replace as necessary.
CAUSE: EL-1500 (Urinal installations) or EL-1500-L (Closet installations) Sensor is not operating.
SOLUTION: Replace EL-1500 or EL-1500-L Sensor.
2. **PROBLEM:** Valve does not function (red light flashes when user steps in front of Sensor).
INDICATOR: Red light stops flashing when user steps away and valve makes a "clicking" sound but does not flush.
CAUSE: No water is being supplied to the valve.
SOLUTION: Make certain that water supply is turned "ON" and the Control Stop is open.
CAUSE: EL-128-A cartridge is fouled or jammed.
SOLUTION: Turn electronic power to valve "OFF" (failure to do so could result in damage to the solenoid coil). Remove the solenoid operator from the valve and remove the EL-128-A cartridge. Clean and/or repair as necessary.
INDICATOR: The red light stops flashing when user steps away but the valve does NOT make a "clicking" sound and does NOT flush.
CAUSE: EL-163-A solenoid shaft assembly is fouled or jammed.
SOLUTION: Turn electronic power to valve "OFF" (failure to do so could result in damage to the solenoid coil). Remove EL-101 or EL-166 nut from the solenoid operator. Remove the coil from the solenoid operator. Use a spanner wrench or pliers to remove the EL-163-A solenoid shaft assembly from valve. Clean and/or replace as necessary. Be sure to replace plunger spring when reassembling Solenoid Shaft Assembly.
INDICATOR: The red light flashes three (3) short flashes, three (3) long flashes then three (3) short flashes ("S-O-S") and continues to repeat this cycle even when user steps out of the sensor's detection range.
CAUSE: Sensor wiring connections are incorrect.
SOLUTION: Refer to Step 10 of this Installation Instructions for proper wiring.
CAUSE: Wiring to Sensor is ground shorted.
SOLUTION: Find short in wiring circuit and correct.
CAUSE: EL-165-2 solenoid coil is burnt out or coil is not connected to solenoid plunger shaft.
SOLUTION: Reinstall or replace coil as necessary.
3. **PROBLEM:** Volume of water is insufficient to adequately siphon fixture.
CAUSE: Control Stop is not open wide enough.
SOLUTION: Adjust control stop for desired water delivery.
CAUSE: Low Consumption unit is installed on Water Saver or Conventional fixture.
SOLUTION: Replace Diaphragm component parts of valve with kit that corresponds to appropriate flush volume of fixture.
CAUSE: Inadequate water volume or pressure available from supply.
SOLUTION: Increase pressure or supply (flow rate) to the valve. Consult factory for assistance.
4. **PROBLEM:** Length of flush is too long (long flushing) or valve fails to shut off.
CAUSE: Water Saver valve is installed on Low Consumption fixture.
SOLUTION: Replace Diaphragm component parts of valve with kit that corresponds to appropriate flush volume of fixture.
CAUSE: Relief valve in diaphragm is not seated properly or bypass hole in diaphragm is clogged.
SOLUTION: Disassemble inside Diaphragm component parts and wash parts thoroughly. Replace worn parts if necessary.
5. **PROBLEM:** Water splashes from fixture.
CAUSE: Supply flow rate is more than necessary.
SOLUTION: Adjust Control Stop to meet flow rate required for proper cleansing of the fixture.

If further assistance is required, please contact Sloan Installation Engineering Department at:
1-888-SLOAN-14 (1-888-756-2614).

!!! IMPORTANT — Control Stop Setting !!!

Never open Control Stop to where the flow from the valve exceeds the flow capability of the fixture. In the event of a valve failure, the fixture must be able to accommodate a continuous flow from the valve.