



Model: WS SB FOR SAVANT THERMOSTAT CLI-W200

Family: WALL-SMART
DWG NO. 028-4-390-SPC



Model No.: 028-1-390

PRODUCT SPEC.

REVISION A
DATE 3/Mar./2019

Make Your Wall Smart

“WS SB FOR SAVANT THERMOSTAT CLI-W200” - Product description:

The “WS SB FOR SAVANT THERMOSTAT CLI-W200” is an adapter for in-wall flush installation of a CLI-W200 thermostat in solid board walls. The “WS SB FOR SAVANT THERMOSTAT CLI-W200” firmly mounts the thermostat while allowing easy access, insertion and removal.

Key features and benefits:

- Thermostat should be connected to a remote temperature sensor.
- Flush with the wall.
- Allows easy insertion and removal of the thermostat by manual push and magnet detachment.
- Designed to be installed in 13.5 ~ 44.5mm (0.53” ~ 1.75”) thick solid boards.
- Installation adapter contains depth adjustment mechanism.
- Installation kit contain:
X1 routing template (item #1)
X1 installation adapter (item #2)
X4 ST3x40 screws (item #3)
X2 M3 nuts (item #4)
X1 Thermostat adapter (item #5)
X2 M3x12 screws (item #6)
- Designed for CLI-W200 thermostat (by Savant) (thermostat not included).

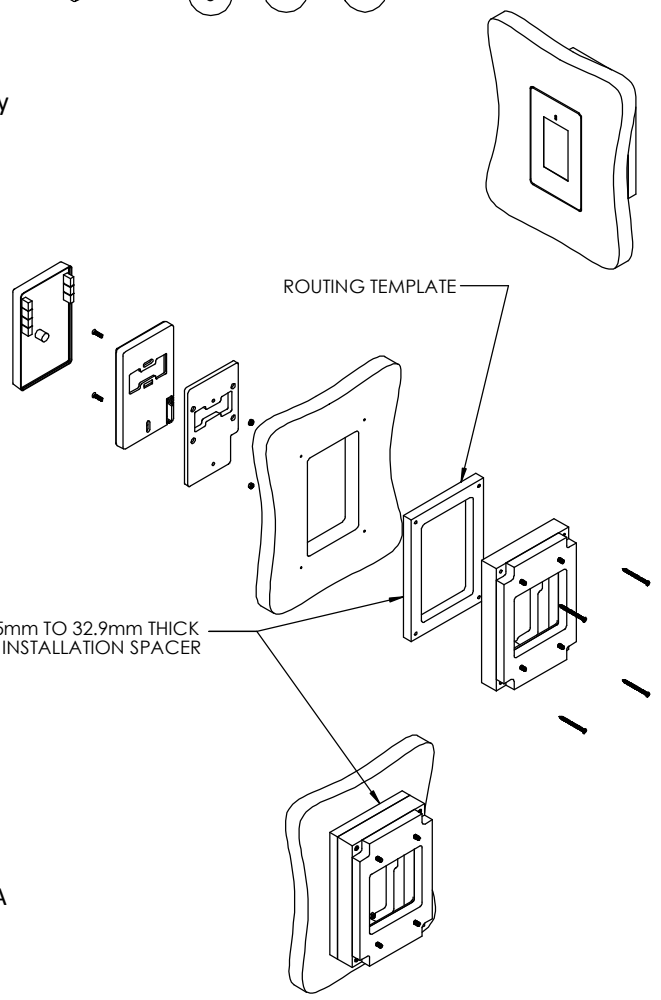
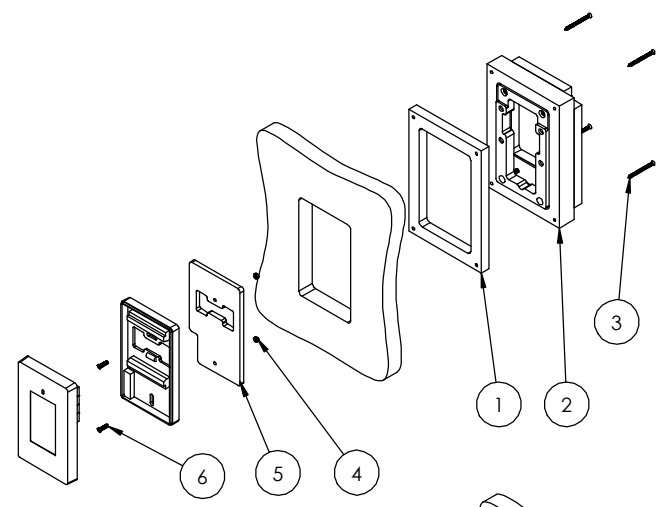

Key properties:

- Dimensions (W/H/D): 108.6mm (4.3")/ 158.2mm (6.23")/ 45.2mm (1.78")
- Power Supply: None (manual adapter).
- Weight: 0.42Kg, 0.924lbs.
- Material: Moisture resistant MDF (compliant with TSCA Title VI)

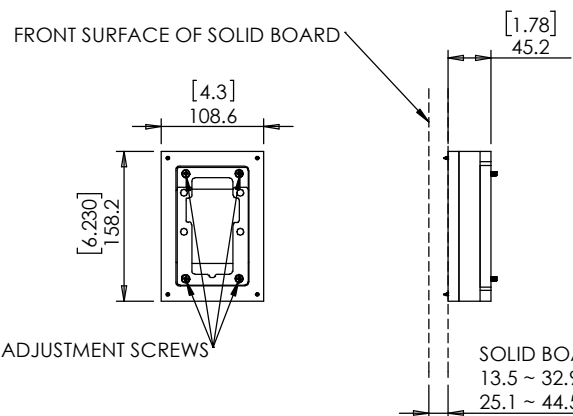

SOLID BOARD THICKNESS RANGE:
13.5 ~ 32.9 [0.53"~1.29"] WITH SPACER
25.1 ~ 44.5 [0.99"~1.75"] WITHOUT SPACER



Model: WS SB FOR SAVANT
THERMOSTAT CLI-W200

Family: WALL-SMART

DWG NO. 028-4-390-SPC

Model No.: 028-1-390

PRODUCT SPEC.

REVISION A

DATE 2/Mar./2019



ROUTING TEMPLATE

SCALE 1:1

