



# BRISTOL POINT

Model # 1906013

## Wooden Swing Set Owner's Manual & Assembly Instructions

MANUFACTURED BY:

Backyard Discovery

3305 Airport Drive  
Pittsburg, KS 66762  
800-856-4445



### WARNING

Adult Assembly Required.

The assembly manual must be retained since it contains important information

Not suitable for children under two years due to sharp points and small parts.

FOR DOMESTIC USE ONLY. INTENDED FOR OUTDOOR USE.

CAN ICES-003 (B)/NMB-003(B)



Before you begin

FOR QUICK &  
EASY ASSEMBLY  
FIND 3D INSTRUCTIONS  
FOR THIS PRODUCT IN

**BILT.**

DOWNLOAD THE FREE APP



average 2 person assembly time



average tube slide assembly time



assembly time may vary based on skill level

For the most up to date assembly manual,  
to register your set or to order replacement parts please visit

[www.backyarddiscovery.com](http://www.backyarddiscovery.com)

SAVE THIS ASSEMBLY MANUAL FOR FUTURE REFERENCE IN THE  
EVENT THAT YOU NEED TO ORDER REPLACEMENT PARTS.

Para obtener instrucciones en español, visite [www.backyarddiscovery.com](http://www.backyarddiscovery.com)



Place the set on level ground, not less than 6 ft 7 in [2 m] from any structure or obstruction such as a fence, garage, house, overhanging branches, laundry lines, or electrical wires.

- While assembling unit, take time before and after each phase to make sure fort is level. If fort is not level, assembly will be difficult and improper assembly may result. Extra care must be taken to insure the fort is square.
- The safe play area refers to a zone extending 6 ft 7 in (2m) beyond the play product on all sides, including the space above the play product.

### SAFE PLAY AREA DIAGRAM

#### Ground Dimension

20'-6 3/8" (6.3m) x 14'-11" (4.5m) x 10'-9 1/8" (3.3m)

#### Safe Play Area

33'-8 3/8" x 28'-1"

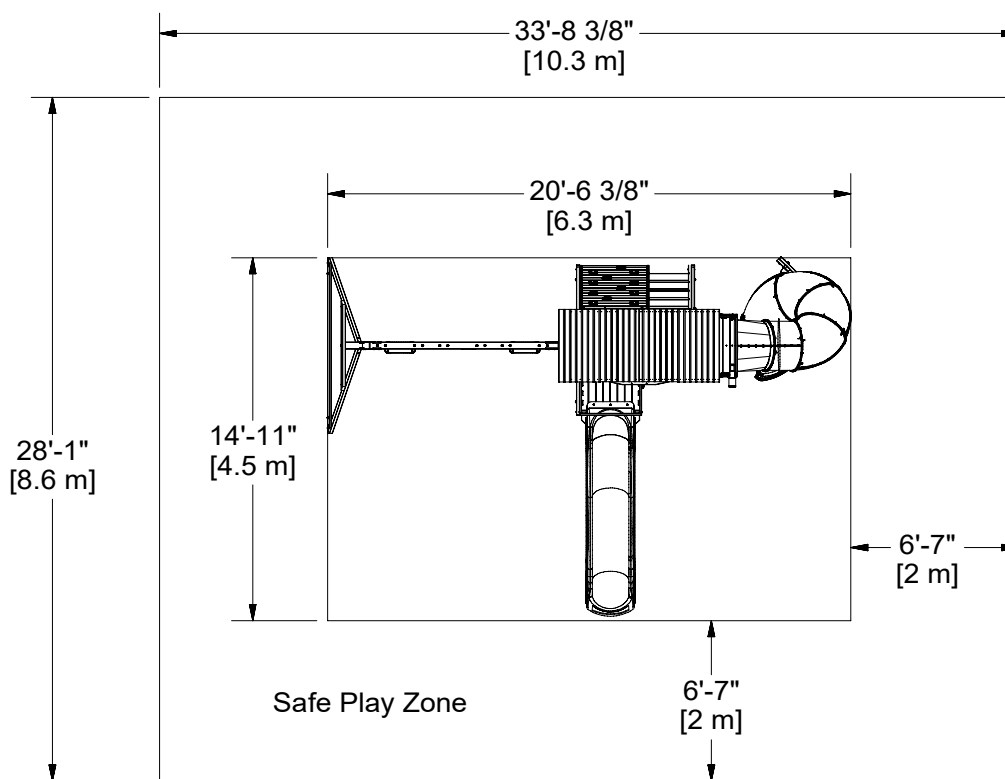

SAFE PLAY HEIGHT: 17'-4 1/8" [5.2M]  
MAXIMUM FALL HEIGHT: 6'-11 1/4" [2.1M]

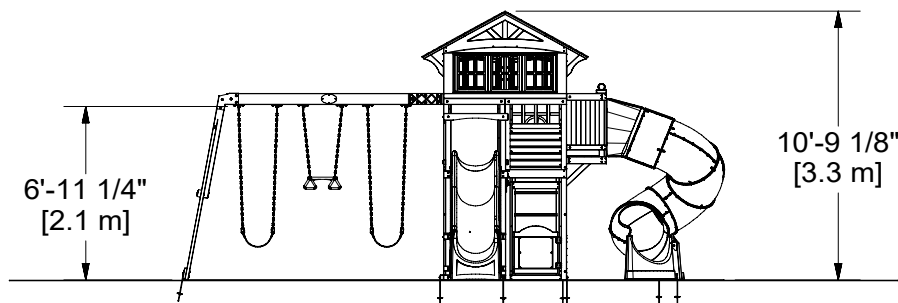

### General Information

Your set has been designed and engineered for children only and for residential use only.  
 A maximum of 150 lbs. per child is recommended for play activities designed for individual use.  
 A maximum of 120 lbs. per child is recommended for play activities designed for multiple child use.  
 A maximum of 9 children is recommended for this swing set.



Wood Components (Not to Scale)



**A1** | SWING BEAM - W4L12327  
(x1) 3-3/8" x 5-1/4" x 89-1/2" (86 x 134 x 2274)



**A2** | SWING BEAM 9" BLOCK - W4L12326  
(x1) 3-3/8" x 5-1/4" x 9" (86 x 134 x 228)

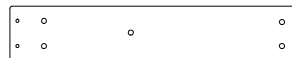

**E1** | RAIL - W4L12344  
(x2) 1-3/8" x 3-3/8" x 18" (36 x 86 x 462)



**E2** | ANGLE BRACE - W4L12328  
(x2) 1-3/8" x 3-3/8" x 88-3/4" (36 x 86 x 2254)

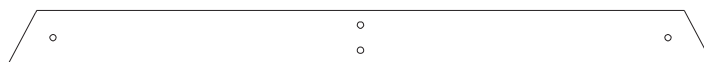

**E3** | END SUPPORT - W4L12329  
(x1) 1-3/8" x 3-3/8" x 44-1/8" (36 x 86 x 1120)



**E80** | LEFT UPRIGHT - W4L11751  
(x1) 1-3/8" x 3-3/8" x 58" (36 x 86 x 1474)

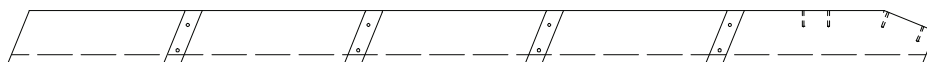

**E81** | MIDDLE UPRIGHT - W4L11752  
(x1) 1-3/8" x 3-3/8" x 58" (36 x 86 x 1474)

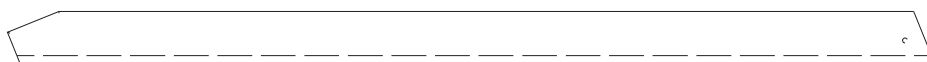

**E83** | RIGHT UPRIGHT - W4L11756  
(x1) 1-3/8" x 3-3/8" x 58" (36 x 86 x 1474)



**F1** | POST - W4L12337  
(x1) 1-3/8" x 2-3/8" x 80" (36 x 60 x 2032)



**F2** | ANGLE BRACE - W4L12343  
(x2) 1-3/8" x 3-3/8" x 20-1/8" (36 x 86 x 510)



**F3** | POST - W4L12481  
(x1) 1-3/8" x 2-3/8" x 80" (36 x 60 x 2032)



**F4** | GROUND BOARD - W4L12487  
(x1) 1-3/8" x 2-3/8" x 74-1/8" (36 x 60 x 1883)



## Wood Components (Not to Scale)



**F5** | **GROUND BOARD - W4L12488**  
(x1) 1-3/8" x 2-3/8" x 24-1/4" (36 x 60 x 617)

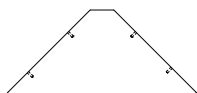

**G1** | **ANGLE BRACE - W4L12473**  
(x1) 1" x 5-1/4" x 12" (24 x 134 x 305)

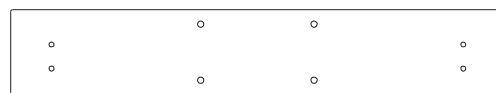

**G2** | **RAIL - W4L12485**  
(x1) 1" x 5-1/4" x 30-7/8" (24 x 134 x 784)



**G50** | **GROUND BOARD - W4L12330**  
(x1) 1" x 5 1/4" x 86 3/4" (24 x 134 x 2202)

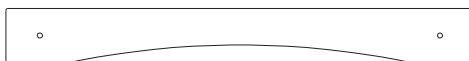

**H2** | **ARCHED RAIL - W4L12342**  
(x1) 1" x 3-3/8" x 29-1/4" (24 x 86 x 744)



**H3** | **FLOOR JOIST - W4L12345**  
(x1) 1" x 3-3/8" x 53-1/4" (24 x 86 x 1352)



**H4** | **RAIL - W4L12452**  
(x1) 1" x 3-3/8" x 18-1/4" (24 x 86 x 462)



**H5** | **FLOOR JOIST - W4L12455**  
(x1) 1" x 3-3/8" x 17-1/4" (24 x 86 x 438)



**H6** | **RAIL - W4L12456**  
(x1) 1" x 3-3/8" x 17-3/8" (24 x 86 x 442)



**H7** | **RAIL - W4L12457**  
(x1) 1" x 3-3/8" x 18" (24 x 86 x 458)



**H8** | **RAIL - W4L12458**  
(x1) 1" x 3-3/8" x 29-1/4" (24 x 86 x 744)



**H9** | **RAIL - W4L12451**  
(x1) 1" x 3-3/8" x 28" (24 x 86 x 712)



**H10** | **ANGLE BRACE - W4L12460**  
(x4) 1" x 3-3/8" x 13-3/8" (24 x 86 x 340)



**H11** | **RAIL - W4L12462**  
(x1) 1" x 2-3/4" x 28" (24 x 71 x 712)

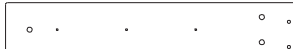

**H12** | **RAIL - W4L12463**  
(x1) 1" x 3-3/8" x 18-1/4" (24 x 86 x 462)



**H13** | **FLOOR JOIST - W4L12482**  
(x1) 1" x 3-3/8" x 23" (24 x 86 x 585)



**H14** | **FLOOR BRACE - W4L12478**  
(x2) 1" x 3-3/8" x 6-3/4" (24 x 86 x 170)

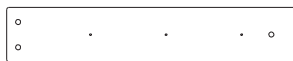

**H15** | **RAIL - W4L12339**  
(x2) 1" x 3-3/8" x 18" (24 x 86 x 458)



**H76** | **LADDER RUNG - W4L11753**  
(x4) 1" x 3-3/8" x 19-3/8" (24 x 86 x 493)



**J1** | **BAY WINDOW SIDE - W4L12333**  
(x2) 1" x 1-7/8" x 18-1/4" (24 x 48 x 464)

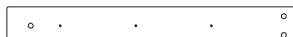

**J2** | **RAIL - W4L12338**  
(x2) 1" x 2-3/8" x 18" (24 x 60 x 458)

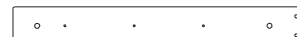

**J3** | **RAIL - W4L12453**  
(x2) 1" x 2-3/8" x 18-1/4" (24 x 60 x 462)

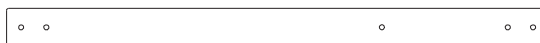

**J4** | **POST - W4L12454**  
(x2) 1" x 2-3/8" x 33-7/8" (24 x 60 x 859)



**J6** | **BRACE - W4L12469**  
(x2) 1" x 2-3/8" x 5-1/8" (24 x 60 x 130)



**J5** | **BRACE - W4L12468**  
(x2) 1" x 2-3/8" x 4-1/2" (24 x 60 x 115)

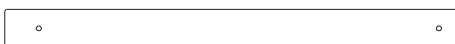

**J7** | **BOTTOM BOARD - W4L12471**  
(x1) 1" x 2-3/8" x 28-3/8" (24 x 60 x 720)

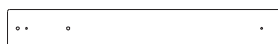

**J8** | **BRACE - W4L12472**  
(x1) 1" x 2-3/8" x 17-1/8" (24 x 60 x 434)



**J9** | **BRACE - W4L12479**  
(x2) 1" x 2-3/8" x 30-1/8" (24 x 60 x 765)



## Wood Components (Not to Scale)



**J10** | DOOR BLOCK - W4L12480  
(x1) | 1" x 2-3/8" x 4-1/2" (24 x 60 x 115)

**J12** | FLOOR SUPPORT - W4L1772  
(x2) | 1" x 2-3/8" x 3-7/8" (24 x 60 x 86)

**J13** | BRACE - W4L12474  
(x2) | 1" x 2-3/8" x 7-7/8" (24 x 60 x 200)

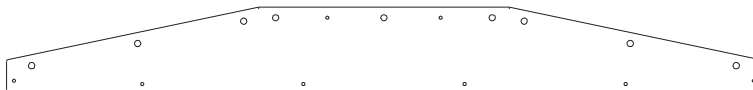

**K1** | BAY WINDOW HEADER - W4L12332  
(x2) | 5/8" x 5-1/4" x 7-1/4" (16 x 134 x 1199)

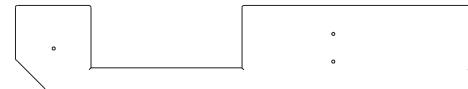

**K2** | COUNTER TOP - W4L12461  
(x1) | 5/8" x 5-1/4" x 28-3/8" (16 x 134 x 720)

**K3** | COUNTER TOP - W4L12464  
(x1) | 5/8" x 5-1/4" x 27-3/8" (16 x 134 x 696)

**K4** | COUNTER TOP - W4L12465  
(x1) | 5/8" x 5-1/4" x 28-3/4" (16 x 134 x 730)

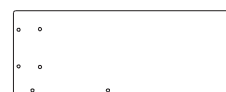
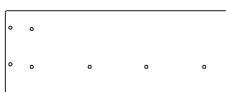
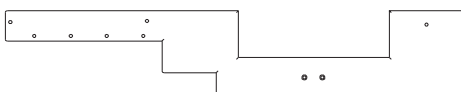

**K5** | COUNTER TOP - W4L12466  
(x1) | 5/8" x 5-1/4" x 28-3/4" (16 x 134 x 730)

**K6** | COUNTER TOP - W4L12467  
(x1) | 5/8" x 5-1/4" x 14-1/8" (16 x 134 x 358)

**K7** | COUNTER TOP - W4L12475  
(x1) | 5/8" x 5-1/4" x 14-1/8" (16 x 134 x 358)



**M73** | REAR SUPPORT - W4L11754  
(x1) | 5/8" x 3-3/8" x 21-1/2" (16 x 86 x 545)

**M74** | ROCK BOARD - W4L11757  
(x8) | 5/8" x 3-3/8" x 31-1/4" (16 x 86 x 794)

**M75** | ROCK BOARD - W4L11758  
(x4) | 5/8" x 3-3/8" x 31-1/4" (16 x 86 x 794)



**M76** | ROCK BOARD - W4L11759  
(x4) | 5/8" x 3-3/8" x 31-1/4" (16 x 86 x 794)

**N1** | RAIL - W4L12334  
(x1) | 5/8" x 2-3/8" x 28-3/8" (16 x 60 x 720)

**N3** | RAIL - W4L12340  
(x6) | 5/8" x 2-3/8" x 24-5/8" (16 x 60 x 626)



**N4** | PICKET - W4L12341  
(x4) | 5/8" x 2-3/8" x 17-5/8" (16 x 60 x 448)

**N5** | RAIL - W4L12470  
(x1) | 5/8" x 2-3/8" x 28-3/8" (16 x 60 x 720)

**N6** | PICKET - W4L12582  
(x6) | 5/8" x 2 3/8" x 27 1/8" (16 x 60 x 690)



**N74** | ROCK BOARD - W4L11760  
(x1) | 5/8" x 2-3/8" x 31-1/4" (16 x 60 x 794)

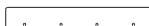

**O1** | TRIM - W4L12476  
(x1) | 5/8" x 1-3/8" x 21-1/4" (16 x 34 x 540)

**O2** | TRIM - W4L12477  
(x2) | 5/8" x 1-3/8" x 9-1/8" (16 x 34 x 233)

**O3** | BLOCK - W4L12603  
(x1) | 5/8" x 1 3/8" x 3 7/8" (16 x 34 x 100)

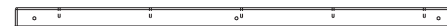

**O70** | SLIDE MOUNTING BOARD - W102822  
(x1) | 5/8" x 1-3/8" x 20-3/8" (16 x 34 x 517)

**T2** | TRIM - W4L12483  
(x1) | 1" x 1-3/8" x 27-5/8" (24 x 34 x 702)

**T3** | TRIM - W4L12484  
(x1) | 1" x 1-3/8" x 27-5/8" (24 x 34 x 702)



**T4** | TRIM - W4L11771  
(x1) | 1" x 1-3/8" x 17" (24 x 34 x 432)

**T5** | WINDOW TRIM - W4L12604  
(x1) | 1" x 1-3/8" x 23-3/8" (24 x 34 x 595)

**T6** | WINDOW TRIM - W4L12605  
(x3) | 1" x 1-3/8" x 11-1/4" (24 x 34 x 285)



**SP50** | SWING BEAM SUPPORT - W4L12331  
(x1) | 3-3/8" x 3-3/8" x 49-3/8" (86 x 86 x 1254)

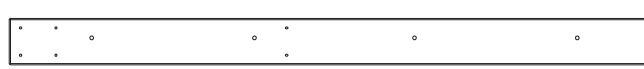
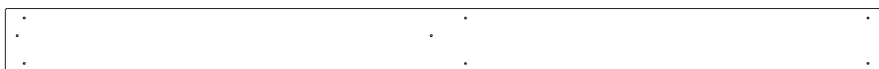

**Y1** | RAIL - W4L12336  
(x1) | 5/8" x 4" x 55-1/8" (16 x 102 x 1400)

**Y2** | ATTACHMENT BOARD - W4L11755  
(x1) | 5/8" x 4" x 56-1/8" (16 x 102 x 1424)



## Wood Components (Not to Scale)

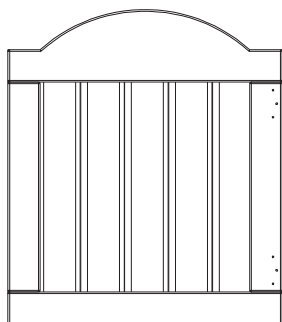

**DP1** | DOOR PANEL - W2A02773  
(x1) | 1-1/16" x 20" x 22-15/16" (27 x 508 x 582)

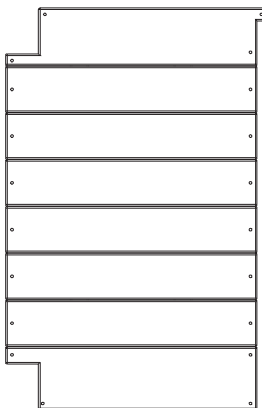

**FP1** | FLOOR PANEL - W2A02777  
(x1) | 1-1/4" x 19" x 29-1/4" (32 x 482 x 744)



**FP2** | FLOOR PANEL - W2A02778  
(x1) | 1-1/4" x 19-9/16" x 30-7/8" (32 x 498 x 784)

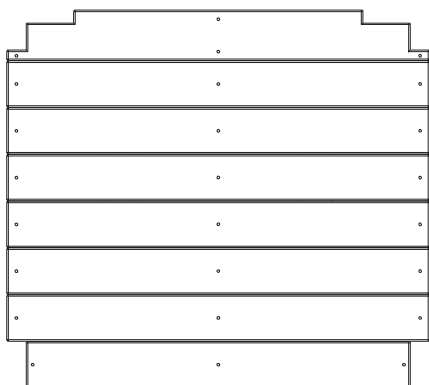

**FP3** | FLOOR PANEL - W2A02779  
(x1) | 1-1/4" x 27-3/4" x 30-7/8" (32 x 705 x 784)

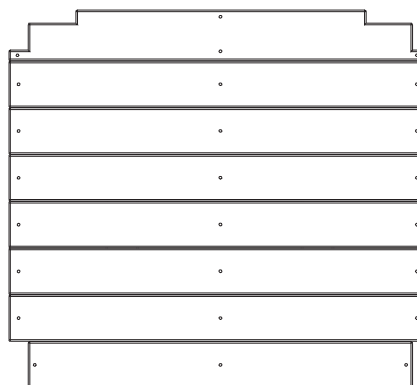

**FP4** | FLOOR PANEL - W2A02780  
(x1) | 1-1/4" x 27-1/2" x 30-3/8" (32 x 699 x 772)

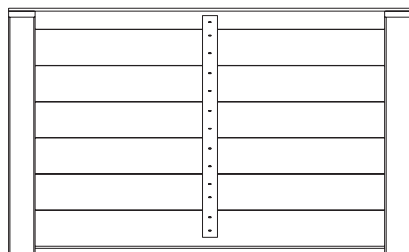

**RP1** | ROOF PANEL - W2A02781  
(x2) | 1-3/8" x 21-7/8" x 35-13/16" (35 x 556 x 910)

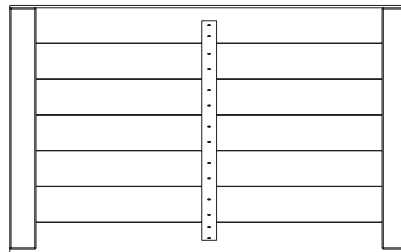

**RP2** | ROOF PANEL - W2A02782  
(x2) | 1-3/8" x 22-5/8" x 35-13/16" (35 x 575 x 910)

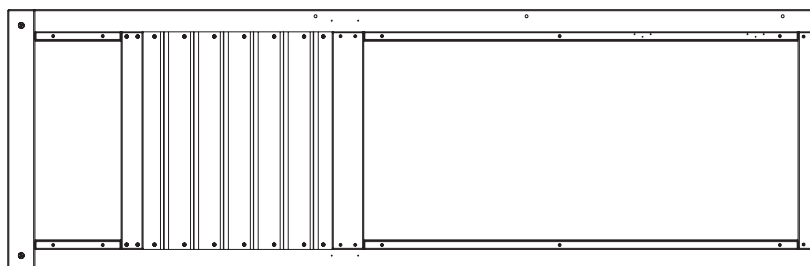

**WP1** | WALL PANEL - W2A02767  
(x1) | 1-7/16" x 28-1/16" x 87-3/16" (36 x 712 x 2214)



## Wood Components (Not to Scale)

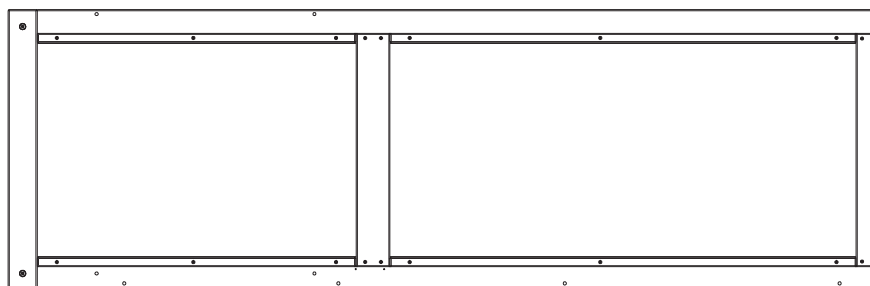

**WP2** | WALL PANEL - W2A02768  
(x1) | 1-7/16" x 28-1/16" x 87-3/16" (36 x 712 x 2214)

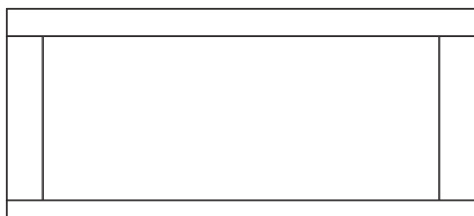

**WP3** | FRONT WINDOW FRAME - W2A02769  
(x1) | 1-7/16" x 25-3/16" x 56-1/16" (36 x 640 x 1424)

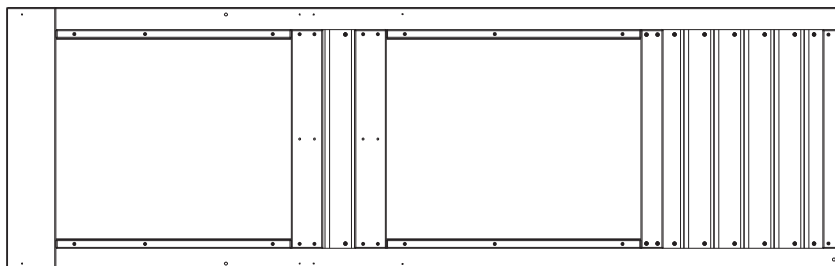

**WP4** | WALL PANEL - W2A02770  
(x1) | 1-7/16" x 28-1/16" x 89-1/2" (36 x 712 x 2274)

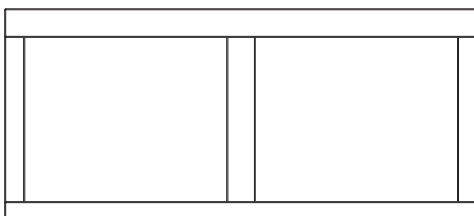

**WP6** | REAR WINDOW FRAME - W2A02772  
(x1) | 1-7/16" x 25-3/16" x 56-1/16" (36 x 640 x 1424)

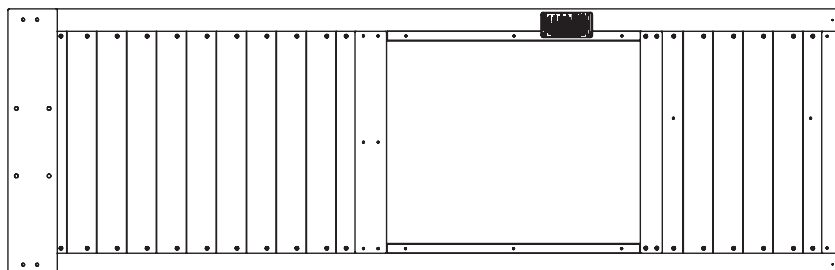

**WP7** | WALL PANEL - W2A02774  
(x1) | 1-7/16" x 28-1/16" x 89-1/2" (36 x 712 x 2274)

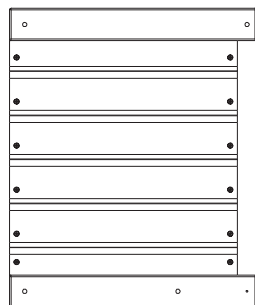

**WP8** | WALL PANEL - W2A02775  
(x1) | 1-7/16" x 18-1/16" x 21-13/16" (36 x 458 x 554)

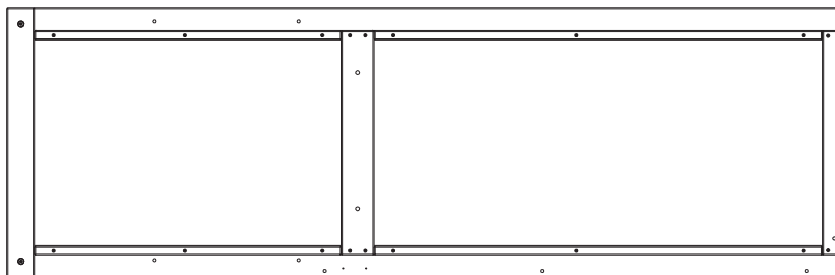

**WP9** | WALL PANEL - W2A02776  
(x1) | 1-7/16" x 28-1/16" x 87-3/16" (36 x 712 x 2214)

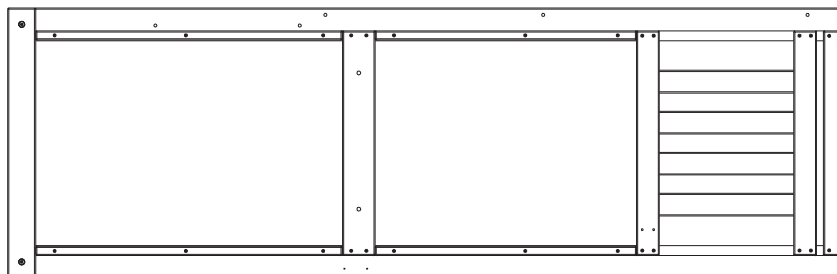

**WP10** | WALL PANEL - W2A02783  
(x1) | 1-9/16" x 28-1/16" x 87-3/16" (40 x 712 x 2214)



## Hardware



**H100085** | **SCREW PFH**  
(x2) 8x1 - H100085



**H100086** | **SCREW PFH**  
(x189) 8x1-1/2 - H100086



**H100087** | **SCREW PFH**  
(x26) 8x1-1/4 - H100087



**H100088** | **SCREW PFH**  
(x53) 8x1-1/8 - H100088



**H100089** | **SCREW PFH**  
(x30) 8x1-3/4 - H100089

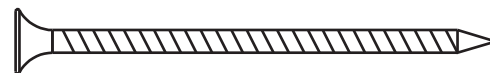

**H100090** | **SCREW PFH**  
(x13) 8x2-1/2 - H100090



**H100092** | **SCREW PFH**  
(x7) 8x3 - H100092



**H100111** | **SCREW PFH**  
(x11) 8x2 - H100111



**H100121** | **SCREW PFH**  
(x3) 8x3/4 - H100121



**H100200** | **SCREW PFH BLK**  
(x22) 8x1-1/2 - H100200



**H100201** | **SCREW PFH BLK**  
(x33) 8x2-1/2 - H100201



**H100202** | **SCREW PWH BLK**  
(x46) 8x5/8 - H100202

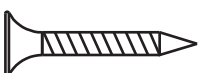

**H100385** | **SCREW PFH BLK**  
(x17) 8x1 - H100385

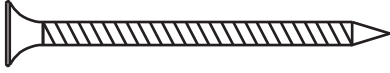

**H100391** | **SCREW PFH BLK**  
(x15) 8x2 - H100391



**H100536** | **SCREW PWH BLK**  
(x2) 8x1-1/4 - H100536

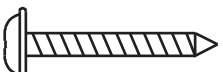

**H100785** | **SCREW PWH**  
(x98) 8x1 - H100785

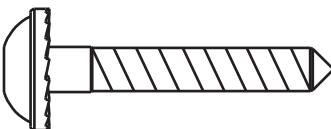

**H100403** | **LAG SCREW WH BLK**  
(x2) 1/4x1-1/2 - H100403

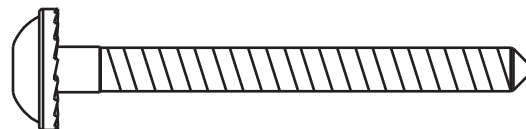

**H100456** | **LAG SCREW WH BLK**  
(x22) 1/4x2-1/2 - H100456

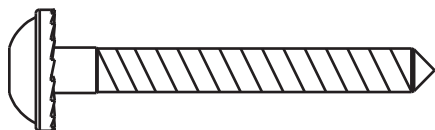

**H100487** | **LAG SCREW WH BLK**  
(x12) 1/4x2 - H100487

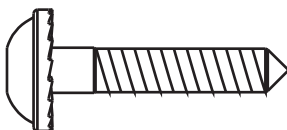

**H100568** | **LAG SCREW WH BLK**  
(x20) 1/4x1-1/4 - H100568

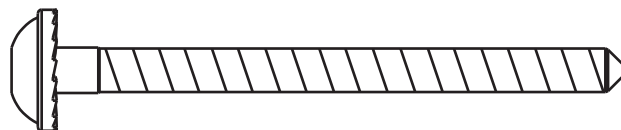

**H100792** | **LAG SCREW WH BLK**  
(x1) 1/4x3 - H100792



## Hardware

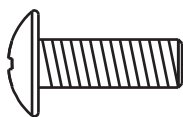

**H100063** | **BOLT PTH**  
(x26) | 1/4 x 3/4 - H100063

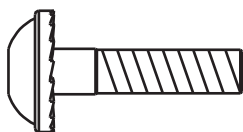

**H100171** | **BOLT WH BLK**  
(x9) | 1/4 x 1 - H100171

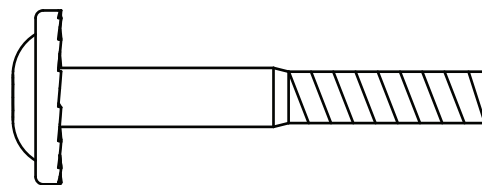

**H100205** | **BOLT WH BLK**  
(x2) | 5/16 x 2-1/4 - H100205

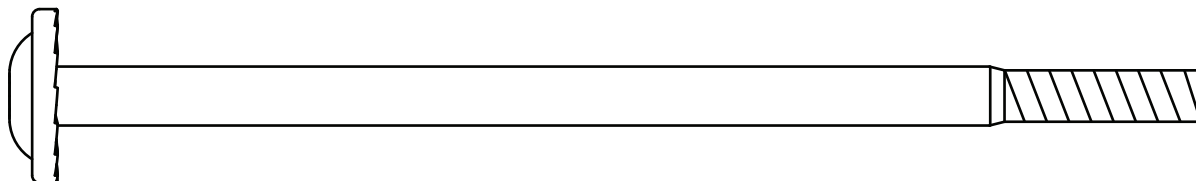

**H100363** | **BOLT WH BLK**  
(x1) | 5/16 x 6 - H100363

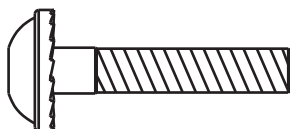

**H100397** | **BOLT WH BLK**  
(x3) | 1/4 x 1-1/4 - H100397

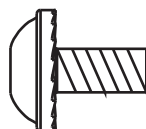

**H100401** | **BOLT WH BLK**  
(x11) | 1/4 x 1/2 - H100401

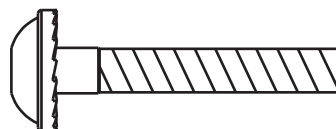

**H100406** | **BOLT WH BLK**  
(x25) | 1/4 x 1-1/2 - H100406

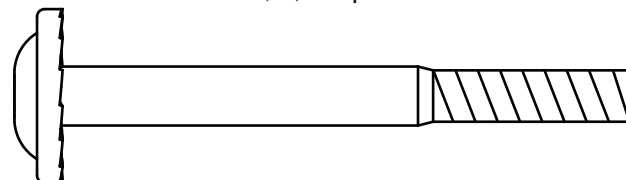
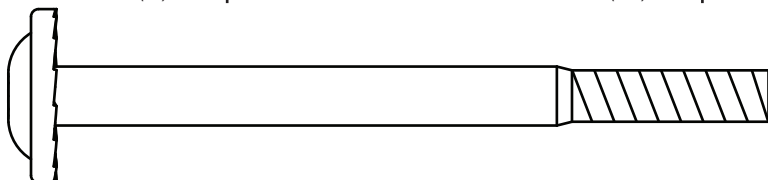

**H100415** | **BOLT WH BLK**  
(x2) | 5/16 x 3-3/4 - H100415

**H100416** | **BOLT WH BLK**  
(x13) | 5/16 x 3 - H100416

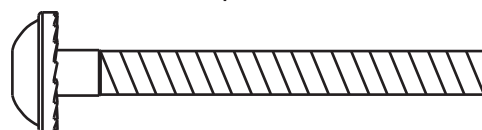
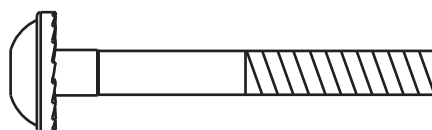
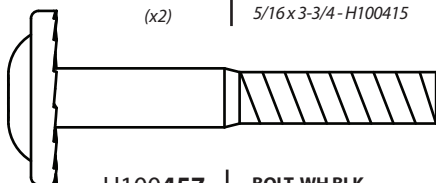

**H100457** | **BOLT WH BLK**  
(x4) | 5/16 x 2 - H100457

**H100488** | **BOLT WH BLK**  
(x18) | 1/4 x 2 - H100488

**H100567** | **BOLT WH BLK**  
(x19) | 1/4 x 2-1/4 - H100567

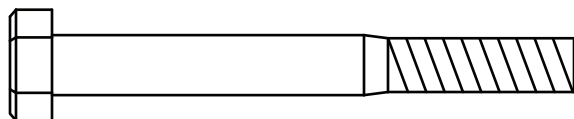

**H100658** | **BOLT HEX BLK**  
(x4) | 5/16 x 2-1/2 - H100658

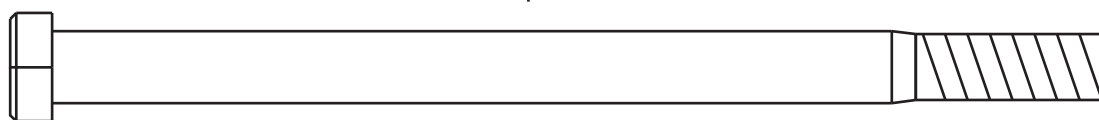

**H100654** | **BOLT HEX**  
(x13) | 3/8 x 5-1/2 - H100654

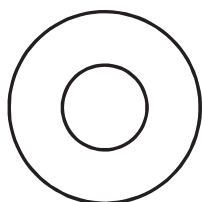

**H100102** | **WASHER FLAT**  
(x13) | 11 x 25 - H100102

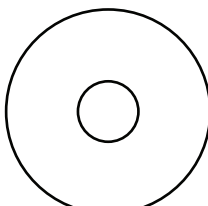

**H100478** | **WASHER FLAT BLK**  
(x4) | 8x27 - H100478

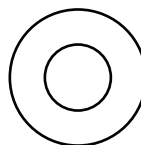

**H100474** | **WASHER FLAT BLK**  
(x8) | 9x18 - H100474

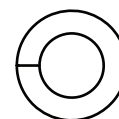

**H100477** | **WASHER SPLIT BLK**  
(x4) | 5/16 - H100477



## Hardware

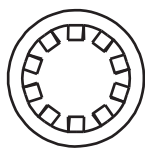

**H100107** | WASHER LOCK INT  
(x13) | 10x18 - H100107

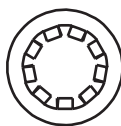

**H100108** | WASHER LOCK INT  
(x26) | 8x15 - H100108

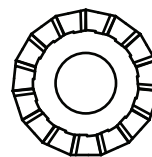

**H100198** | WASHER LOCK EXT BLK  
(x10) | 8x19 - H100198

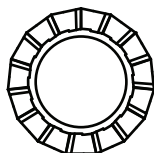

**H100199** | WASHER LOCK EXT BLK  
(x10) | 12x19 - H100199

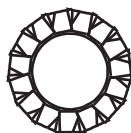

**H100400** | WASHER LOCK EXT BLK  
(x40) | 8x15 - H100400

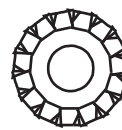

**H100405** | WASHER LOCK EXT BLK  
(x69) | 6x15 - H100405

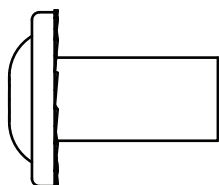

**H100192** | NUT BARREL WH BLK  
(x21) | 5/16x7/8 - H100192

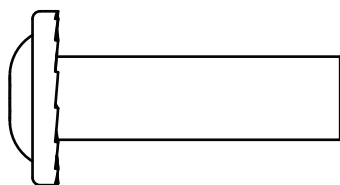

**H100193** | NUT BARREL WH BLK  
(x2) | 5/16x1-1/2 - H100193

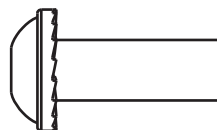

**H100399** | NUT BARREL WH BLK  
(x34) | 1/4x7/8 - H100399

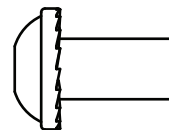

**H100404** | NUT BARREL WH BLK  
(x6) | 1/4x5/8 - H100404



**H100072** | T-NUT  
(x26) | 1/4 - H100072

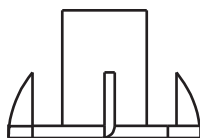

**H100073** | T-NUT  
(x13) | 3/8 - H100073

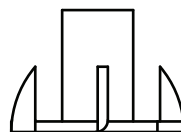

**H100379** | T-NUT BLK  
(x4) | 5/16 - H100379



**H100398** | T-NUT BLK  
(x44) | 1/4 - H100398

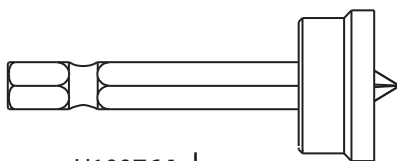

**H100764** | SCREW SETTER  
(x1) | H100764

**9220119** | TOOL KIT  
(1)

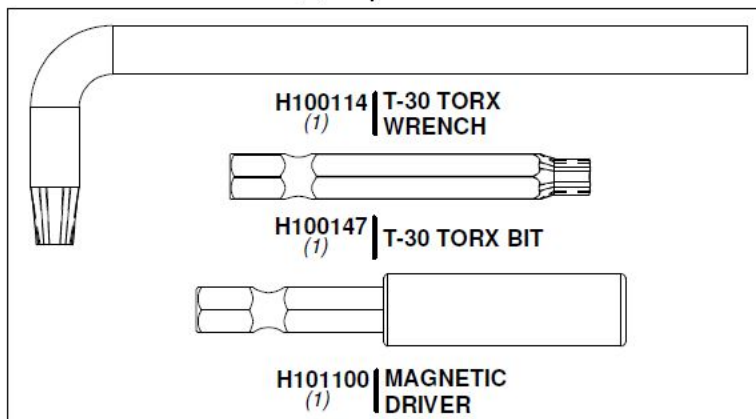

**H100114** | T-30 TORX  
(1) | WRENCH

**H100147** | T-30 TORX BIT  
(1)

**H101100** | MAGNETIC  
(1) | DRIVER



Accessories (Not to Scale)



A6P00054 | SWING SEAT GREEN 22"  
(x2) A6P00054



A100047 | CHAIN GREEN 57"  
(x4) A100047



A4M00710 | L BRACKET BLACK 32X51  
(x11) A4M00710



A100069 | QUICK LINK  
(x6) A100069



A100107 | STEERING WHEEL KIT  
(x1) A100107



A100118 | HAND GRIP  
(x3) A100118



A100164 | BYD ID TAG  
(x1) A100164



A100177 | CHAIN GREEN 31"  
(x2) A100177



A100178 | G METAL GROUND STAKE  
(x7) BROWN - A100178



A100314 | 'A' REVISION TAG  
(x1) A100314



A100327 | HINGE, SPRING LOADED  
(x1) A100327

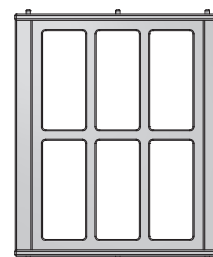

A100373 | BAY WINDOW PANEL  
(x3) A100373

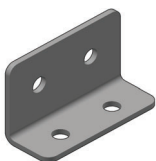

A4M00855 | L BRACKET 51X32X82X3.125  
(x6) A4M00855



A4M00505 | SWING HANGER  
(x6) QUICK LINK - A4M00505

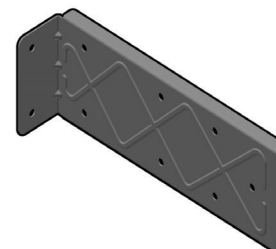

A4M00993 | EXT. SWING BEAM BRACKET  
(x2) A4M00993



Accessories (Not to Scale)



A4M00555 | L BRACKET BLK  
(x2) A4M00555



A4M00558 | HINGE, NON-SPRING LOADED  
(x1) A4M00558

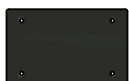

A4M00995 | METAL CLEAT  
(x2) A4M00995

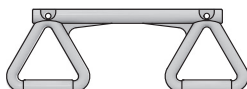

A6P00034 | TRAPEZE  
(x1) A6P00034



A6P00036 | GREEN HC ROCK #1  
(x6) A6P00036



A6P00037 | GREEN HC ROCK #2  
(x6) A6P00037

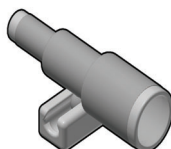

A6P00096 | TELESCOPE  
(x1) A6P00096

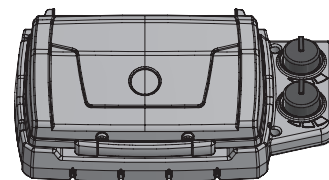

A6P00282 | BBQ GRILL  
(x1) A6P00282

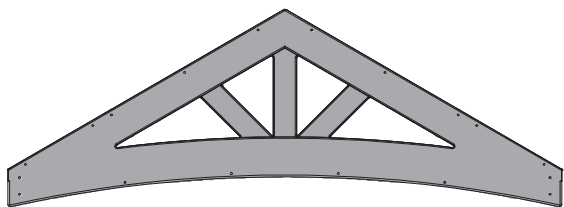

A6P00319 | ARCHED GABLE  
(x2) A6P00319

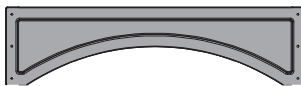

A6P00320 | ARCHED SIDE  
(x2) A6P00320

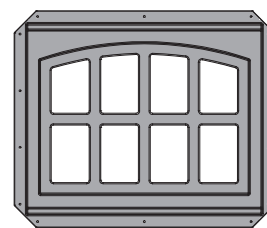

A6P00321 | ARCHED WINDOW  
(x2) A6P00321

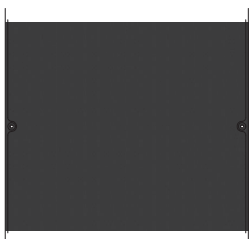

A6P00323 | CHALK BOARD  
(x1) A6P00323

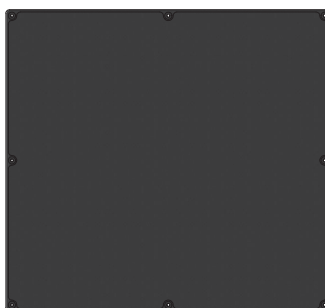

A6P00324 | CHALK BOARD LARGE  
(x1) A6P00324

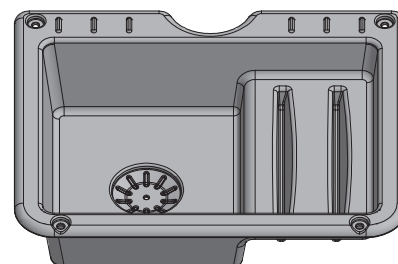

A6P00332 | PREMIUM SINK  
(x1) A6P00332



**A4M00554** | **BELL ASSEMBLY**  
(x1) | A4M00554

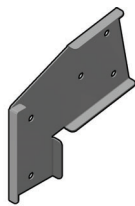

**A100325** | **SWING BEAM EXT. BRACKET**  
(x1) | Left - A100325

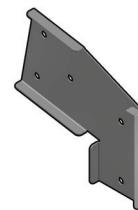

**A100326** | **SWING BEAM EXT. BRACKET**  
(x1) | Right - A100326

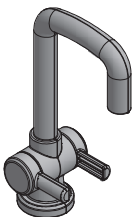

**A6P00333** | **FAUCET**  
(x1) | A6P00333

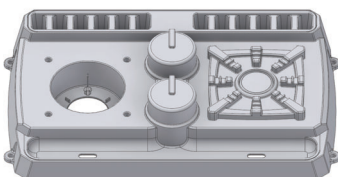

**A6P00335** | **STOVE BASE**  
(x1) | A6P00335

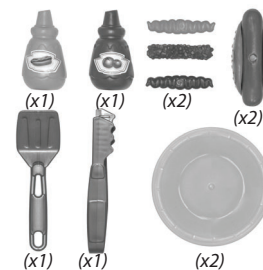

**A6P00327** | **GRILL FOOD SET**  
(x1) | A6P00327

**! BE SURE TO WASH ALL PLASTIC TOYS BEFORE USE.**

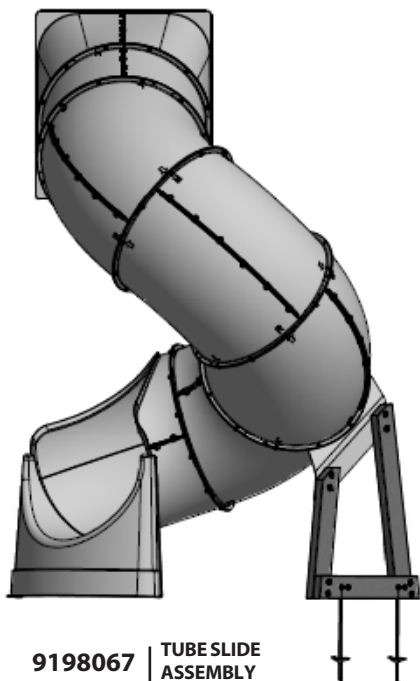

**9198067** | **TUBE SLIDE ASSEMBLY**  
(x1) | 9198067



**A6P00336** | **BOIL POT**  
(x1) | A6P00336



**A6P00337** | **POT/PAN LID**  
(x2) | A6P00337



**A6P00338** | **FRY PAN**  
(x1) | A6P00338



**A6P00339** | **SPATULA**  
(x1) | A6P00339



**A6P00340** | **LADLE**  
(x1) | A6P00340



**A6P00331** | **BLENDER**  
(x1) | A6P00331

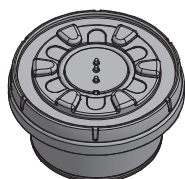

**A6P00330** | **INDUCTIVE BURNER**  
(x1) | A6P00330

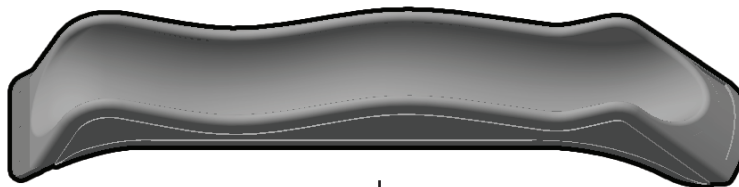

**A100287** | **SLIDE V F 10 FT**  
(x1) | A100287

**NOTE:** THIS DEVICE COMPLIES WITH PART 15 OF THE FCC RULES. OPERATION IS SUBJECT TO THE FOLLOWING TWO CONDITIONS: (1) THIS DEVICE MAY NOT CAUSE HARMFUL INTERFERENCE (2) THIS DEVICE MUST ACCEPT ANY INTERFERENCE RECEIVED, INCLUDING INTERFERENCE THAT MAY CAUSE UNDESIRABLE OPERATION.

FCC LABEL

# PRE-ASSEMBLY STEP 1 - SORTING PARTS

It is critical for ease of assembly that you take the time to sort and organize the wood and hardware.

---

## WOOD PARTS:

- Organize wood parts by the three-digit, alpha-numeric number stamped on each board (ex. P01).
- If there are multiple boards with the same stamped number, stack those pieces together.
- Stamps can be found on the flat surface of the boards or on the end of the boards.
- Allow yourself plenty of room - the wood pieces can take up a significant amount of space.

**NOTE: CARTONS ARE NOT ORGANIZED BY BOARD NUMBER.**

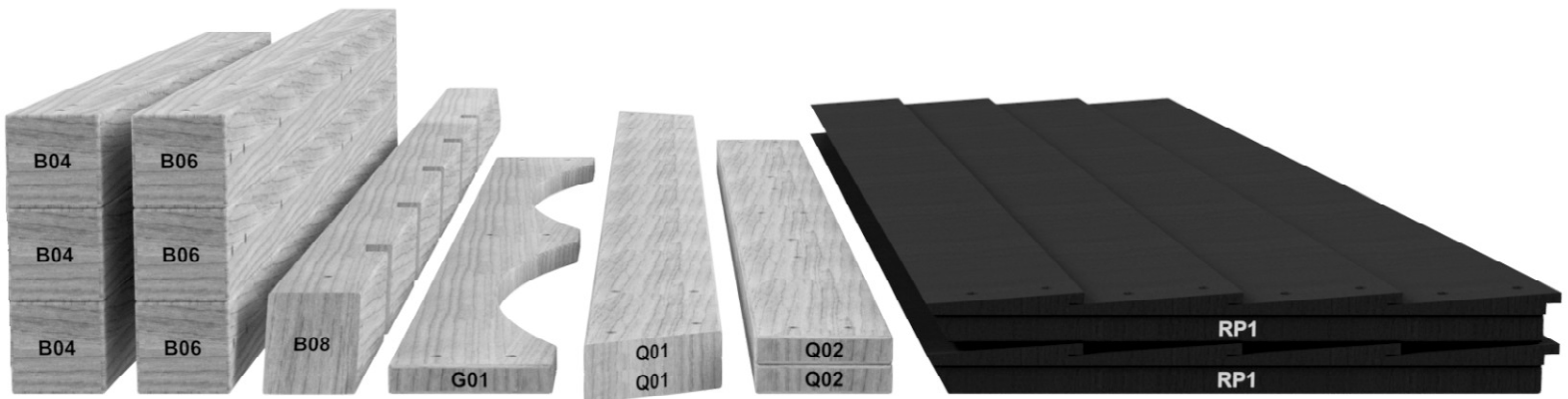

---

## HARDWARE PARTS:

- We recommend that you have a separate table to organize the hardware.
- Hardware bags are printed with a seven-digit, alpha-numeric part number.
- You can organize your hardware by part number or group by hardware type (i.e. bolts, nuts, etc.).
- During assembly you only need to reference the last four digits of the number.

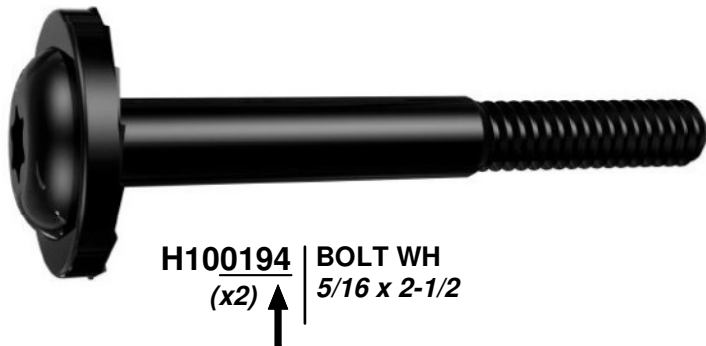

# PRE-ASSEMBLY STEP 2 - TOOLS REQUIRED



**Cordless Drill or  
Electric Drill**



**Drill Attachments:  
Phillips Head**



**1/8", 3/16", 3/8" & 7/16"  
Drill Bits**



**Phillips Screw Driver**



**Open End Wrenches 1/2" & 9/16"**



**3/8" Drive Ratchet, 1/2" &  
9/16" STD Sockets 1/2" & 9/16" Deep  
Sockets**



**Claw Hammer**



**Rubber Mallet - Optional**



**Tape Measure**

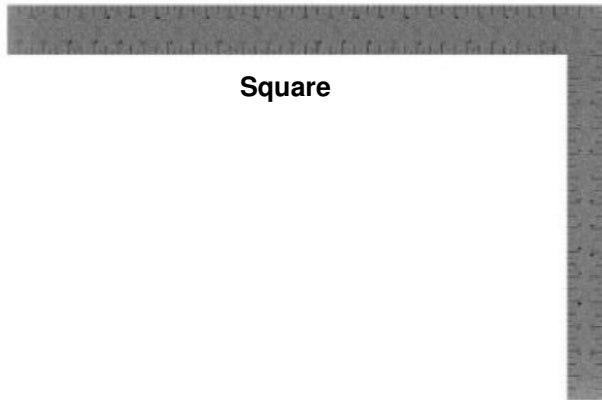

**Square**



**Level 24"**

# PRE-ASSEMBLY STEP 3 - CHOOSE YOUR ASSEMBLY METHOD

There are several types of assembly instructions available to you.

1. Printed Assembly Manual included with your set
2. BILT APP - 3D interactive instructions
3. Combination of the Printed Manual and BILT APP (Note: Step numbers can differ between the two methods)

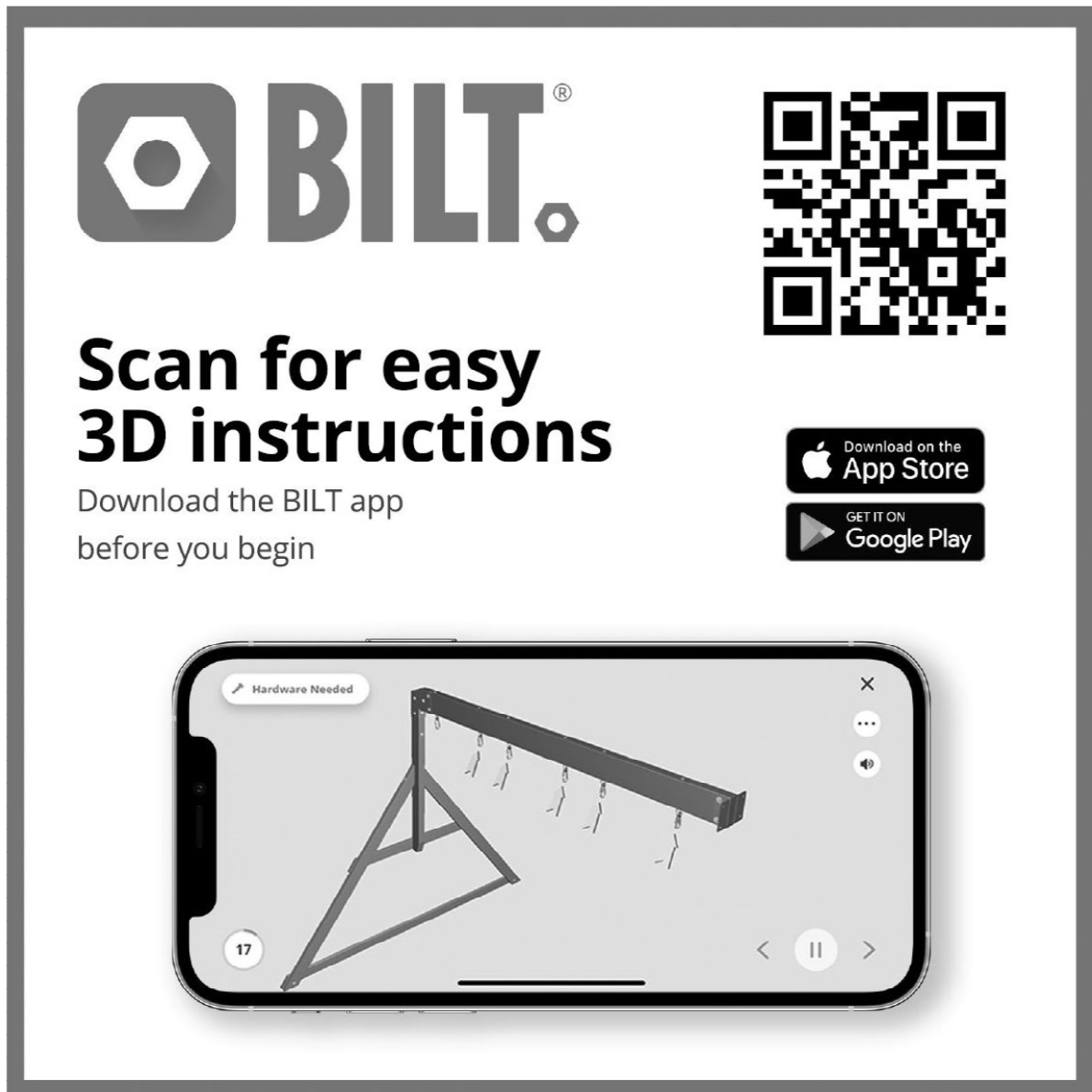

The advertisement features the BILT logo on the left, a QR code on the right, and a central text area. Below the text are two app store download buttons and a smartphone mockup showing the app's interface. The smartphone screen displays a 3D assembly diagram of a metal frame with a horizontal beam and hanging components. The interface includes a 'Hardware Needed' label, a step number '17', and navigation controls like back, play/pause, and forward buttons.

**BILT.**<sup>®</sup>

**Scan for easy  
3D instructions**

Download the BILT app  
before you begin

Download on the  
App Store

GET IT ON  
Google Play

Hardware Needed

17



# Phase 1

# STEP 1



**A1** | **SWING BEAM EXTENDED - W4L12327**  
(x1) 3-3/8" x 5-1/4" x 89-1/2" (86 x 134 x 2274)



**A4M00505** | **SWING HANGER QUICK LINK**  
(x6) A4M00505



**H100073** | **T-NUT**  
(x12) 3/8 - H100073

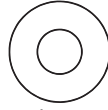

**H100102** | **WASHER FLAT**  
(x12) 11x25 - H100102



**H100107** | **WASHER LOCK INT**  
(x12) 10x18 - H100107

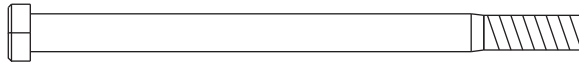

**H100654** | **BOLT HEX**  
(x12) 3/8 x 5-1/2 - H100654

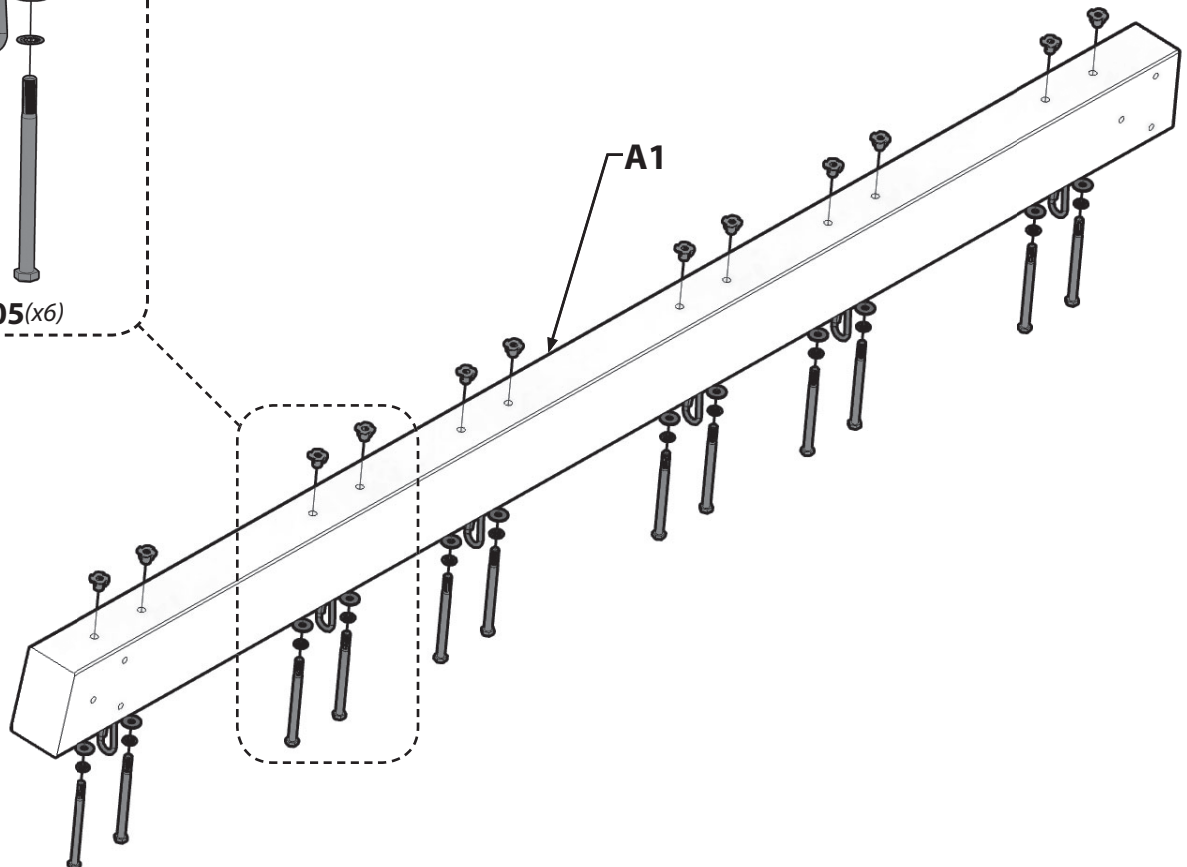
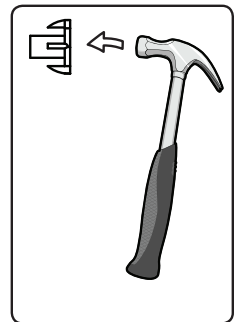
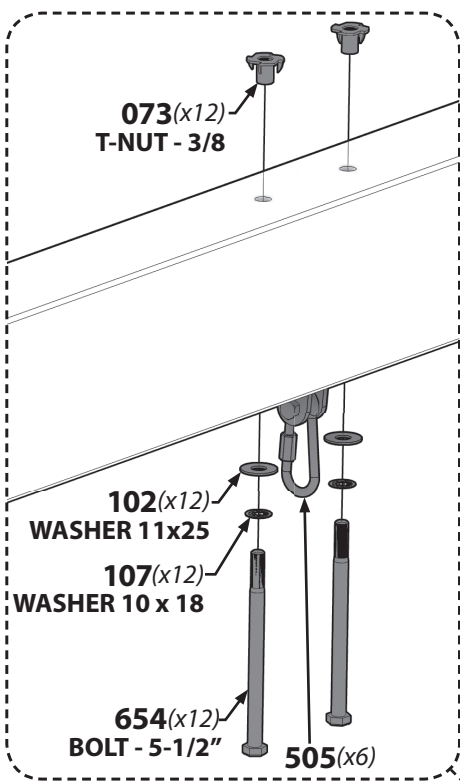



# Phase 1

## STEP 2



**SP50** | SWING BEAM SUPPORT - W4L12331  
(x1) | 3-3/8" x 3-3/8" x 49-3/8" (86 x 86 x 1254)

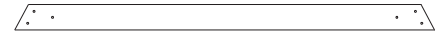

**G50** | GROUND BOARD - W4L12330  
(x1) | 1" x 5-1/4" x 86-3/4" (24 x 134 x 2202)

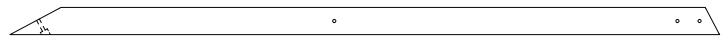

**E2** | ANGLE BRACE - W4L12328  
(x2) | 1-3/8" x 3-3/8" x 88-3/4" (36 x 86 x 2254)

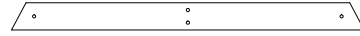

**E3** | END SUPPORT - W4L12329  
(x1) | 1-3/8" x 3-3/8" x 44-1/8" (36 x 86 x 1120)

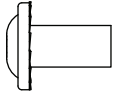

**H100192** | NUT BARREL WH BLK  
(x7) | 5/16 x 7/8 - H100192

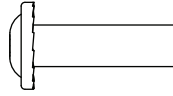

**H100193** | NUT BARREL WH BLK  
(x2) | 5/16 x 1-1/2 - H100193



**H100198** | WASHER LOCK EXT BLK  
(x9) | 8 x 19 - H100198



**H100199** | WASHER LOCK EXT BLK  
(x9) | 12 x 19 - H100199

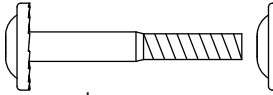

**H100205** | BOLT WH BLK  
(x2) | 5/16 x 2-1/4 - H100205

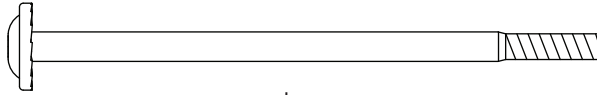

**H100363** | BOLT WH BLK  
(x1) | 5/16 x 6 - H100363

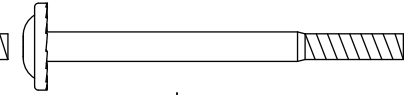

**H100415** | BOLT WH BLK  
(x2) | 5/16 x 3-3/4 - H100415

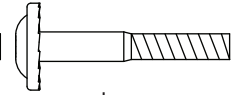

**H100457** | BOLT WH BLK  
(x4) | 5/16 x 2 - H100457

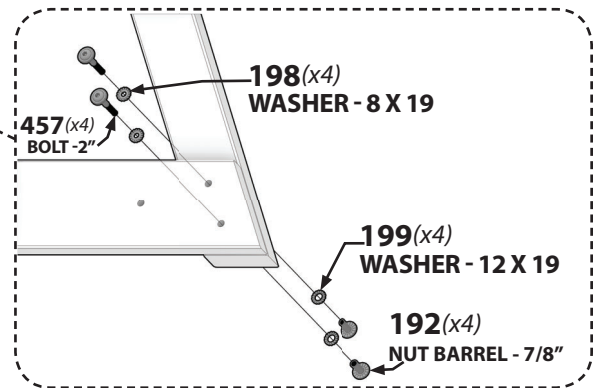
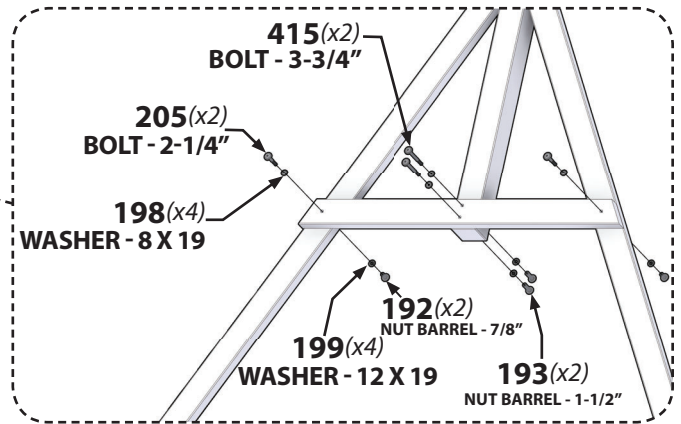
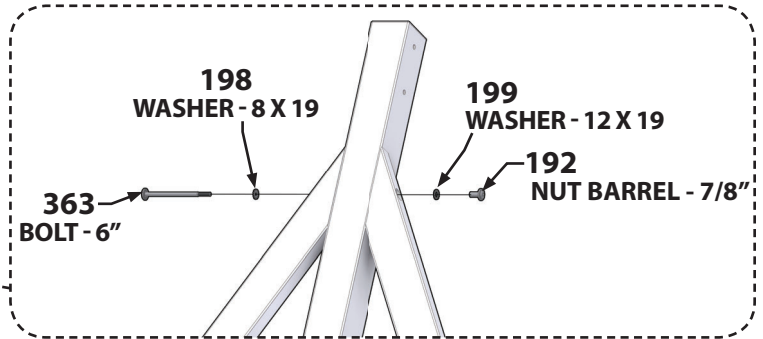
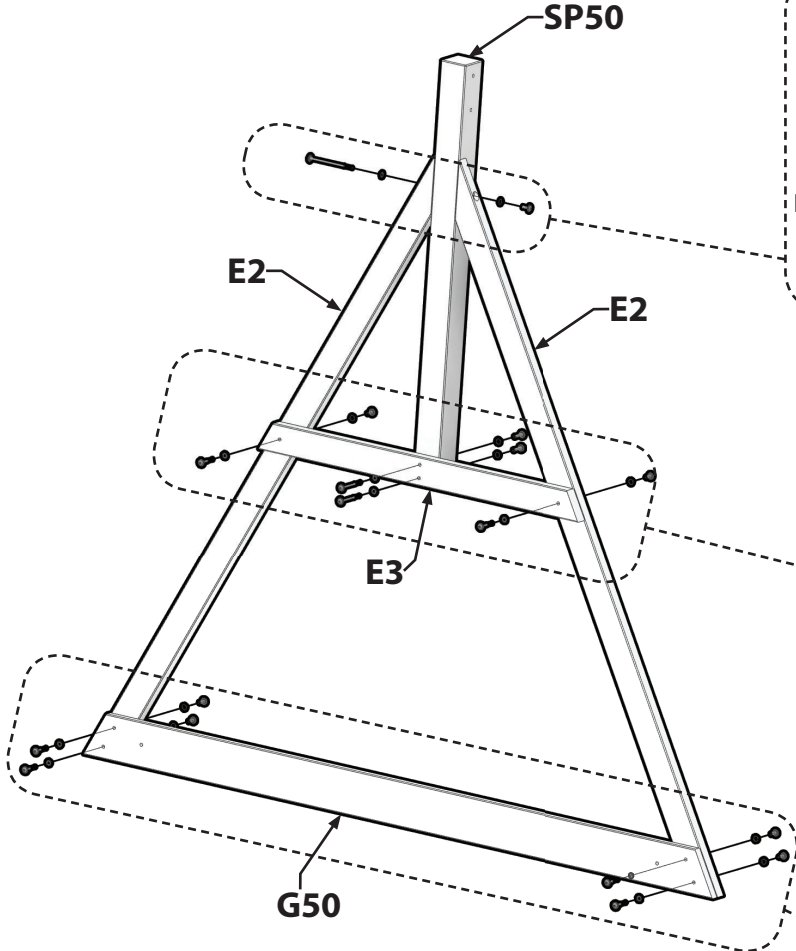

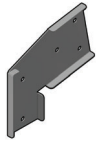

**A100325** | SWING BEAM EXT. BRACKET  
(x1) | Left - A100325

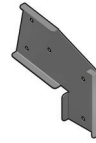

**A100326** | SWING BEAM EXT. BRACKET  
(x1) | Right - A100326

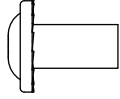

**H100192** | NUT BARREL WH BLK  
(x5) | 5/16x7/8 - H100192

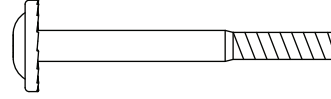

**H100416** | BOLT WH BLK  
(x5) | 5/16x3 - H100416

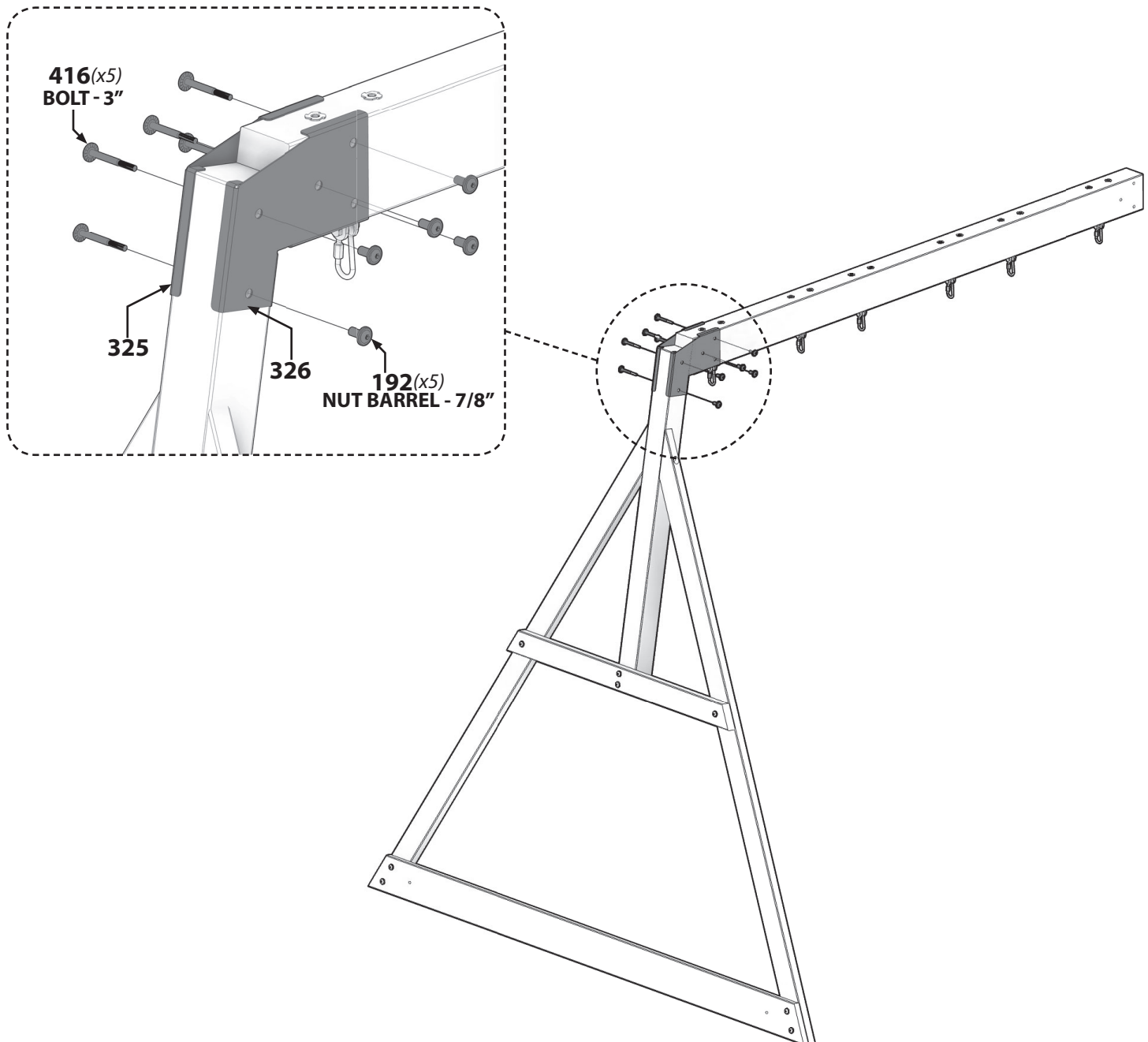



# Phase 1

## STEP 4



**A2** | SWING BEAM 9" BLOCK - W4L12326  
(x1) | 3-3/8" x 5-1/4" x 9" (86 x 134 x 228)

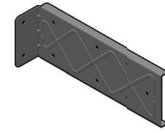

**A4M00993** | EXT. SWING BEAM BRACKET  
(x2) | A4M00993

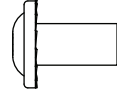

**H100192** | NUT BARREL WH BLK  
(x7) | 5/16 x 7/8 - H100192

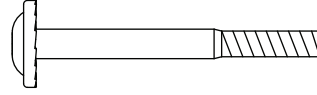

**H100416** | BOLT WH BLK  
(x7) | 5/16 x 3 - H100416

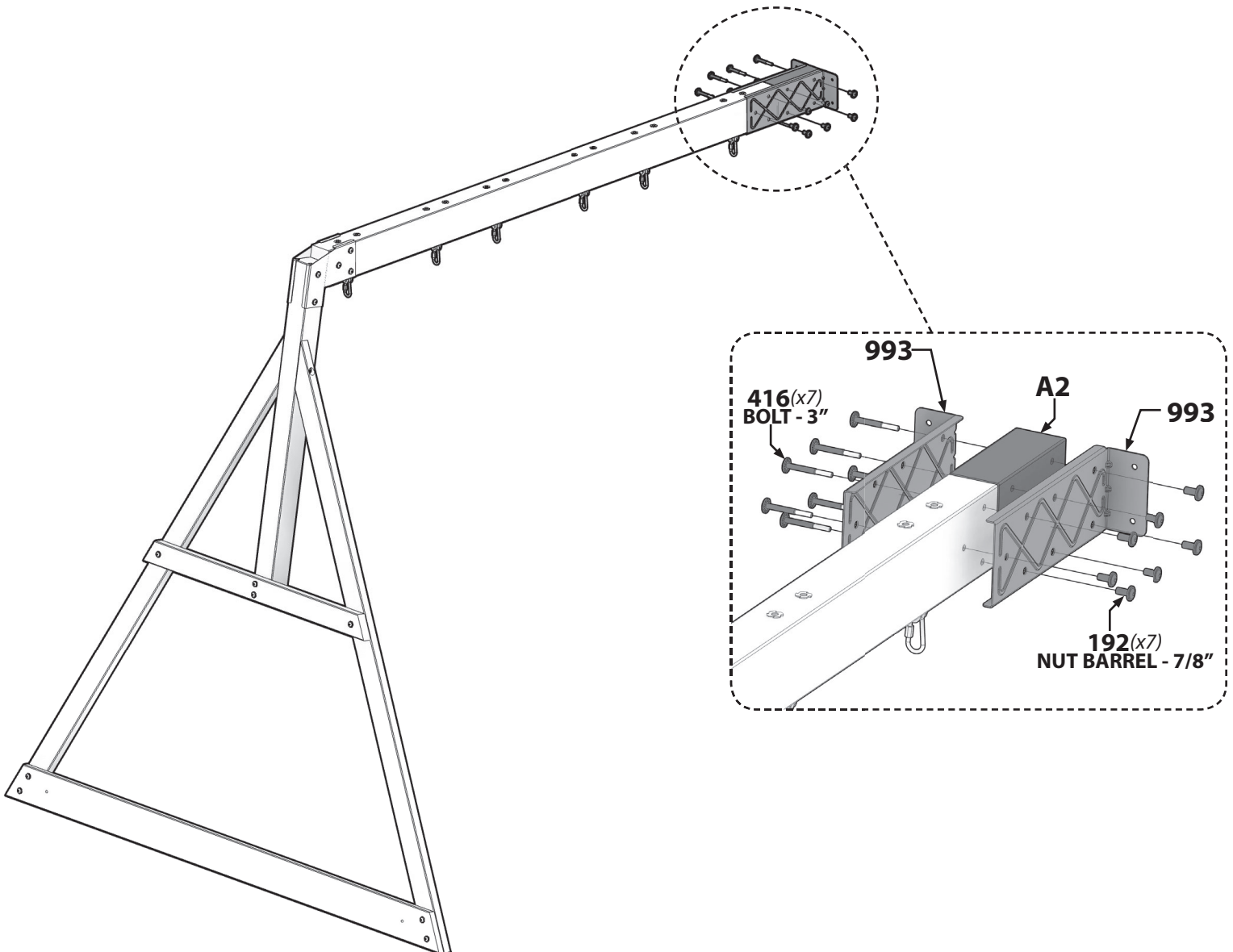



# Phase 2

# STEP 1



**E80** | LEFT UPRIGHT - W4L11751  
(x1) | 1-3/8" x 3-3/8" x 58" (36 x 86 x 1474)



**H76** | LADDER RUNG - W4L11753  
(x4) | 1" x 3-3/8" x 19-3/8" (24 x 86 x 493)



**H100201** | SCREW PFH BLK  
(x8) | 8x2-1/2 - H100201

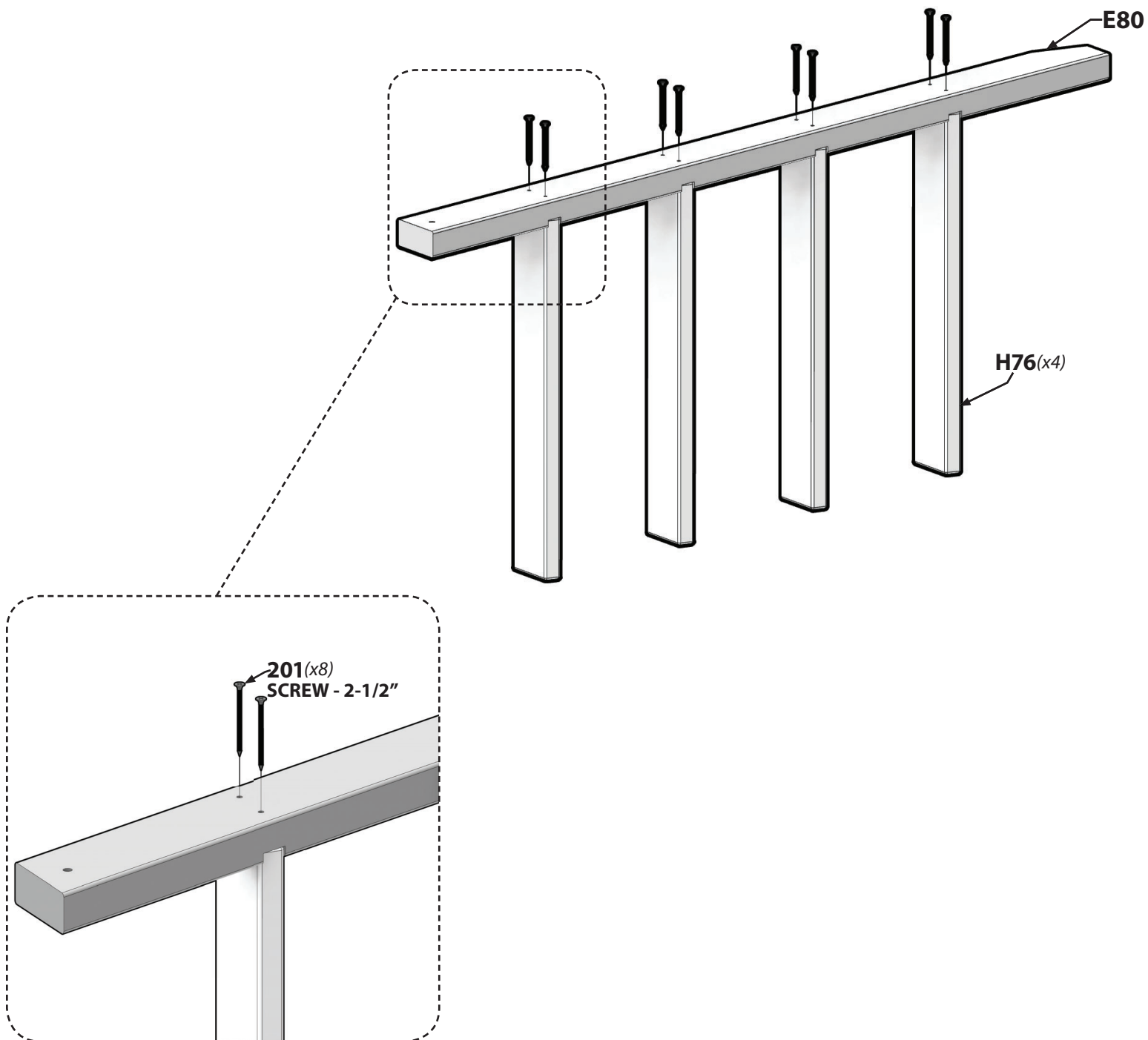

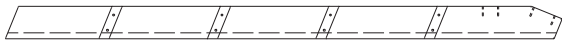

**E81** | **MIDDLE UPRIGHT - W4L11752**  
(x1) | 1-3/8" x 3-3/8" x 58" (24 x 86 x 1474)



**H100201** | **SCREW PFH BLK**  
(x8) | 8x2-1/2 - H100201

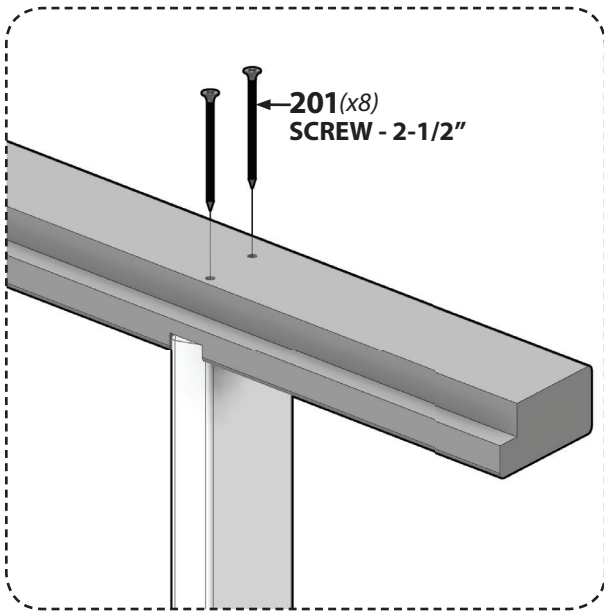
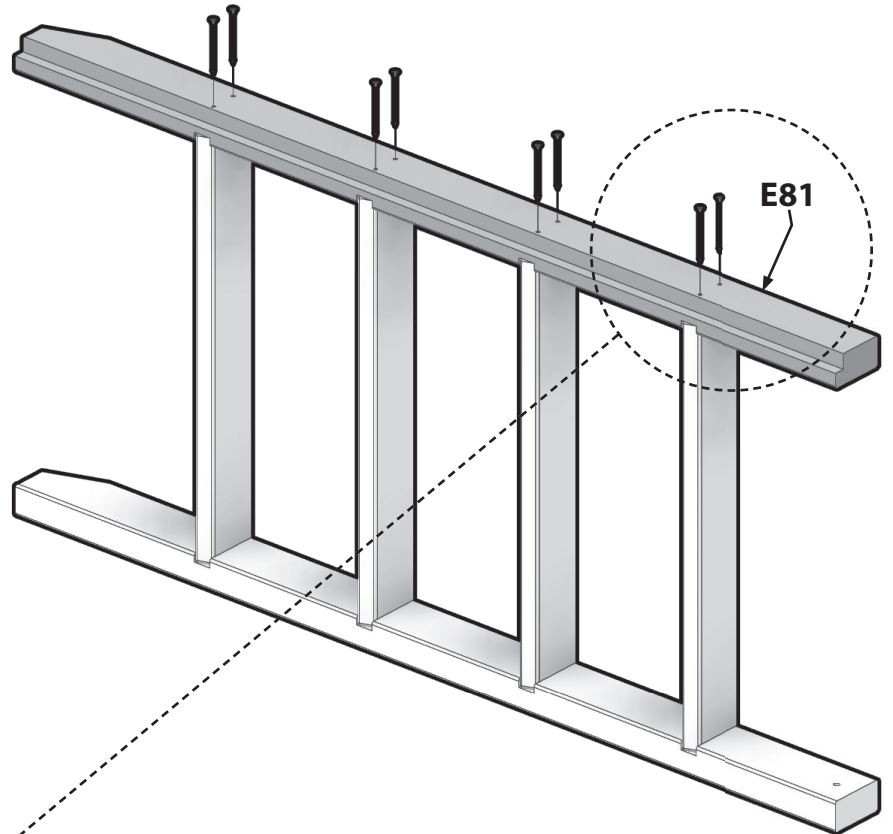



# Phase 2

# STEP 3

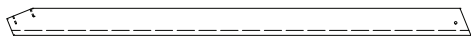

**E83** | RIGHT UPRIGHT - W4L11756  
(x1) | 1-3/8" x 3-3/8" x 58" (24 x 86 x 1474)

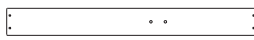

**M75** | ROCK BOARD - W4L11758  
(x4) | 5/8" x 3-3/8" x 31-1/4" (16 x 86 x 794)



**A6P00036** | GREEN HC ROCK #1  
(x6) | A6P00036

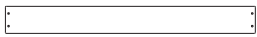

**M74** | ROCK BOARD - W4L11757  
(x8) | 5/8" x 3-3/8" x 31-1/4" (16 x 86 x 794)



**M76** | ROCK BOARD - W4L11759  
(x4) | 5/8" x 3-3/8" x 31-1/4" (16 x 86 x 794)

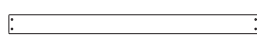

**N74** | ROCK BOARD - W4L11760  
(x1) | 5/8" x 2-3/8" x 31-1/4" (16 x 60 x 794)



**A6P00037** | GREEN HC ROCK #2  
(x6) | A6P00037



**H100063** | BOLT PTH  
(x24) | 1/4 x 3/4 - H100063



**H100072** | T-NUT  
(x24) | 1/4 - H100072



**H100086** | SCREW PFH  
(x60) | 8x1-1/2 - H100086



**H100108** | WASHER LOCKINT  
(x24) | 8x15 - H100108

**NOTE: BUILD (4) ONE ROCK SUB-ASSEMBLIES AND (4) TWO ROCK SUB-ASSEMBLIES, AS SHOWN BELOW.**

(2) M75 BOARD ORIENTATION WILL BE ROTATED CLOCKWISE 180 DEGREES. SEE EXAMPLE BELOW:

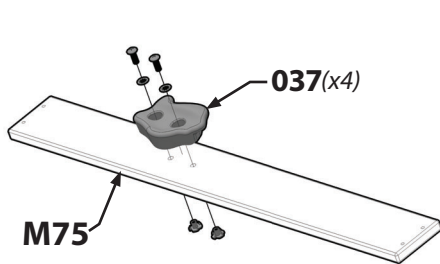
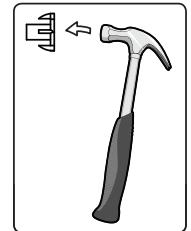

**M75-A**  
(x2)

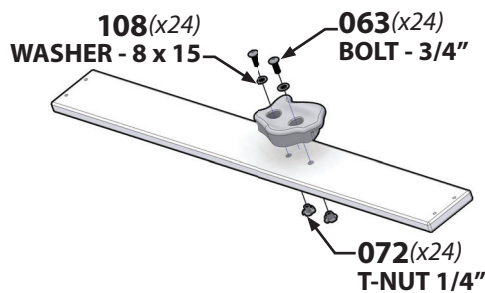

**M75-B**  
(x2)

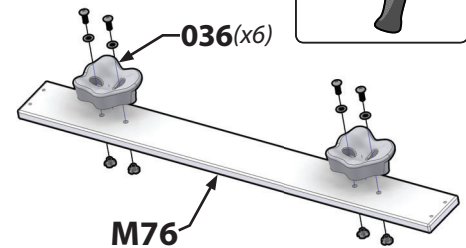

**M76**  
(x4)

**ASSEMBLE ROCK BOARDS TO UPRIGHTS AS SHOWN BELOW. DO NOT ASSEMBLE THE TOP (2) ROCK BOARDS AT THIS TIME. THE TOP (2) ROCK BOARDS WILL BE ASSEMBLED IN A LATER STEP.**



**M74** | ROCK BOARD - W4L11757  
(x1) | 5/8" x 3-3/8" x 31-1/4" (16 x 86 x 794)



**M76** | ROCK BOARD SUB-ASSEMBLY - W4L11759  
(x1) | 5/8" x 3-3/8" x 31-1/4" (16 x 86 x 794)

**PLACE ROCKS WITH ARROW POINTING UP.**



**NOTE: THE ROCK BOARD PATTERN IS M74, M75, M74, M76.**

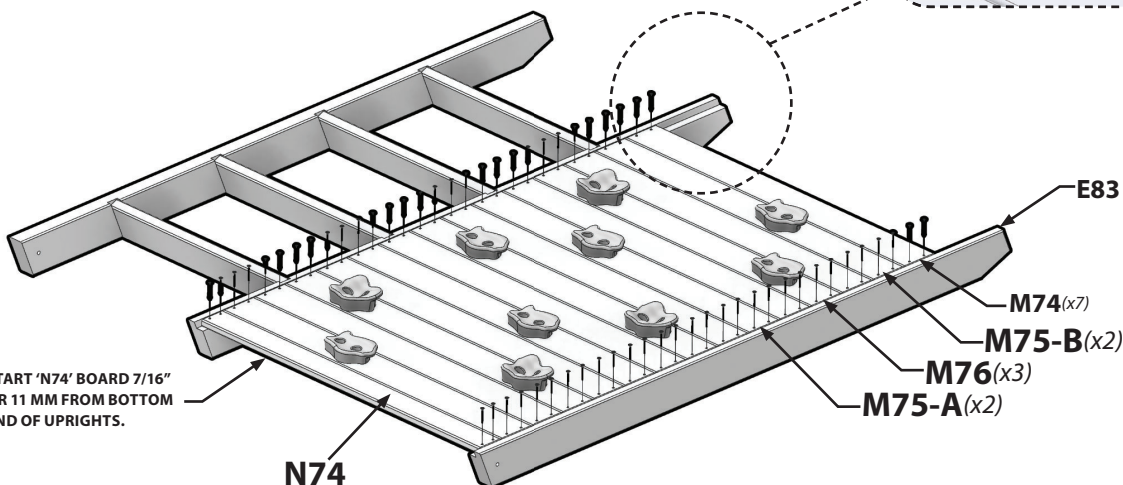
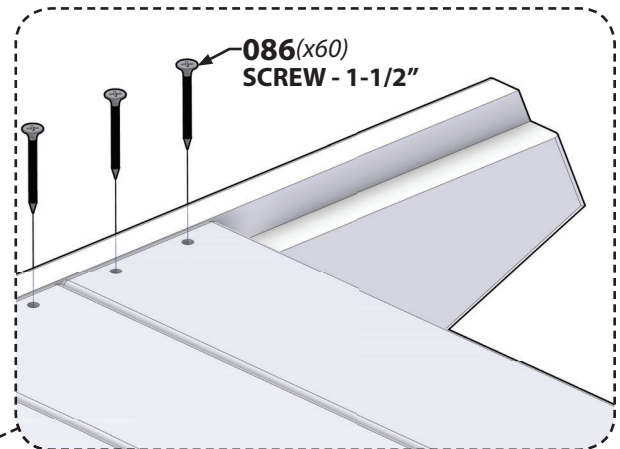

START 'N74' BOARD 7/16" OR 11 MM FROM BOTTOM END OF UPRIGHTS.



# Phase 2

## STEP 4

TOP		BOTTOM	
<b>Y2</b> (x1)	<b>ATTACHMENT BOARD - W4L11755</b> 5/8" x 4" x 56-1/8" (16 x 102 x 1424)		
<b>M73</b> (x1)	<b>REAR SUPPORT - W4L11754</b> 5/8" x 3-3/8" x 21-1/2" (16 x 86 x 545)		

 **H100086** | **SCREW PFH**  
(x4) | 8x1-1/2 - H100086

 **H100391** | **SCREW PFH BLK**  
(x6) | 8x2 - H100391

**NOTE: ORIENTATION, ALSO BE SURE TO USE PILOT HOLES AS A GUIDE TO LOCATE SCREW LOCATION ON BOARDS "Y2" AND "M73".**

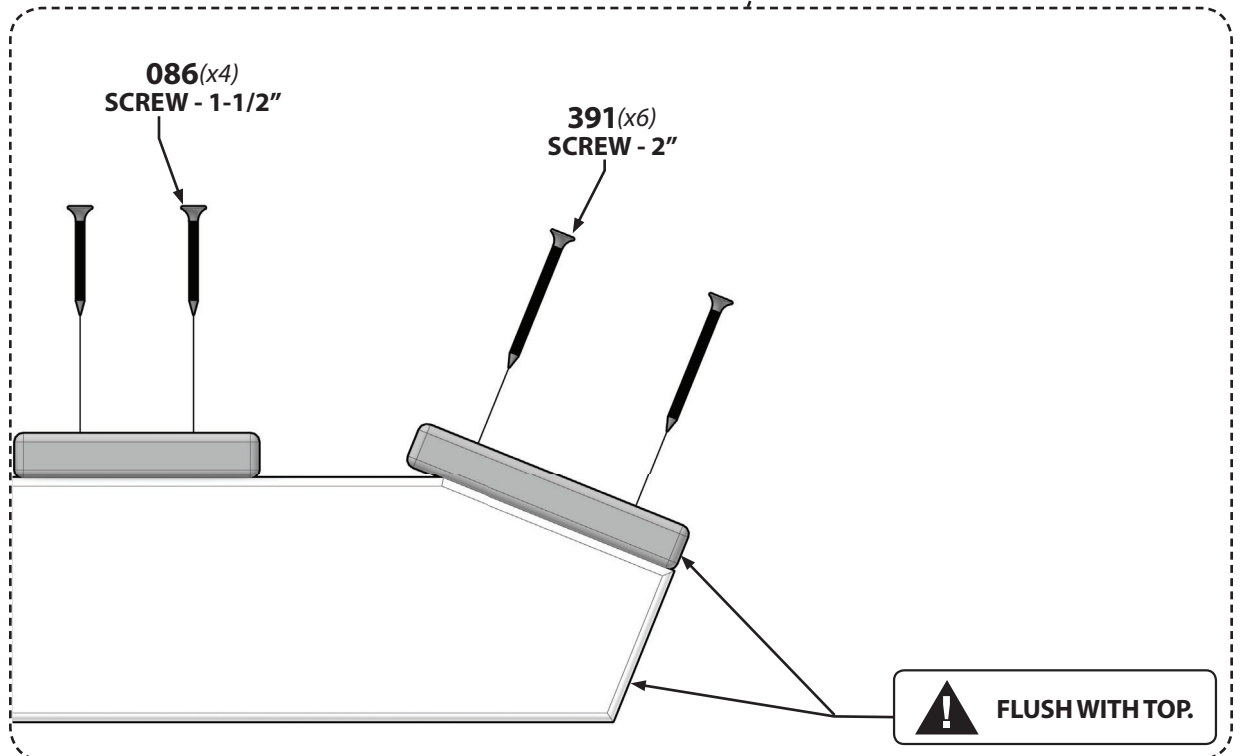
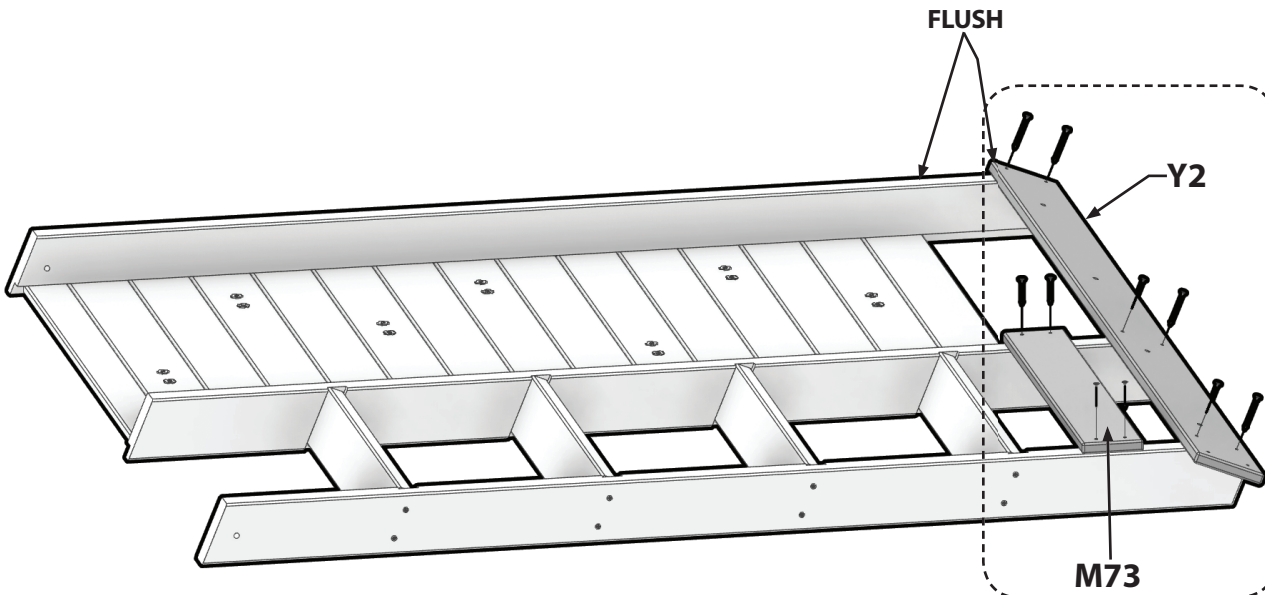

 **FLUSH WITH TOP.**



**T5** | WINDOW TRIM - W4L12604  
(x1) | 1"x1 3/8"x23 3/8" (24x34x595)

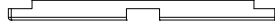

**T6** | WINDOW TRIM - W4L12605  
(x3) | 1"x1 3/8"x11 1/4" (24x34x285)

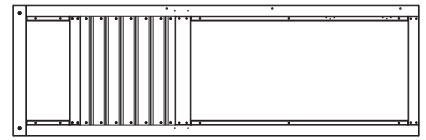

**WP1** | WALL PANEL - W2A02767  
(x1) | 1-7/16"x28-1/16"x87-3/16" (36x712x2214)



**H100087** | SCREW PFH  
(x8) | 8x1-1/4" - H100087



**H100121** | SCREW PFH  
(x3) | 8x3/4" - H100121



### ASSEMBLY NOTE:

USE PILOT HOLES AS GUIDE.  
USE 121(x3)SCREWS IN INTERIOR HOLES ON T5 BOARD.

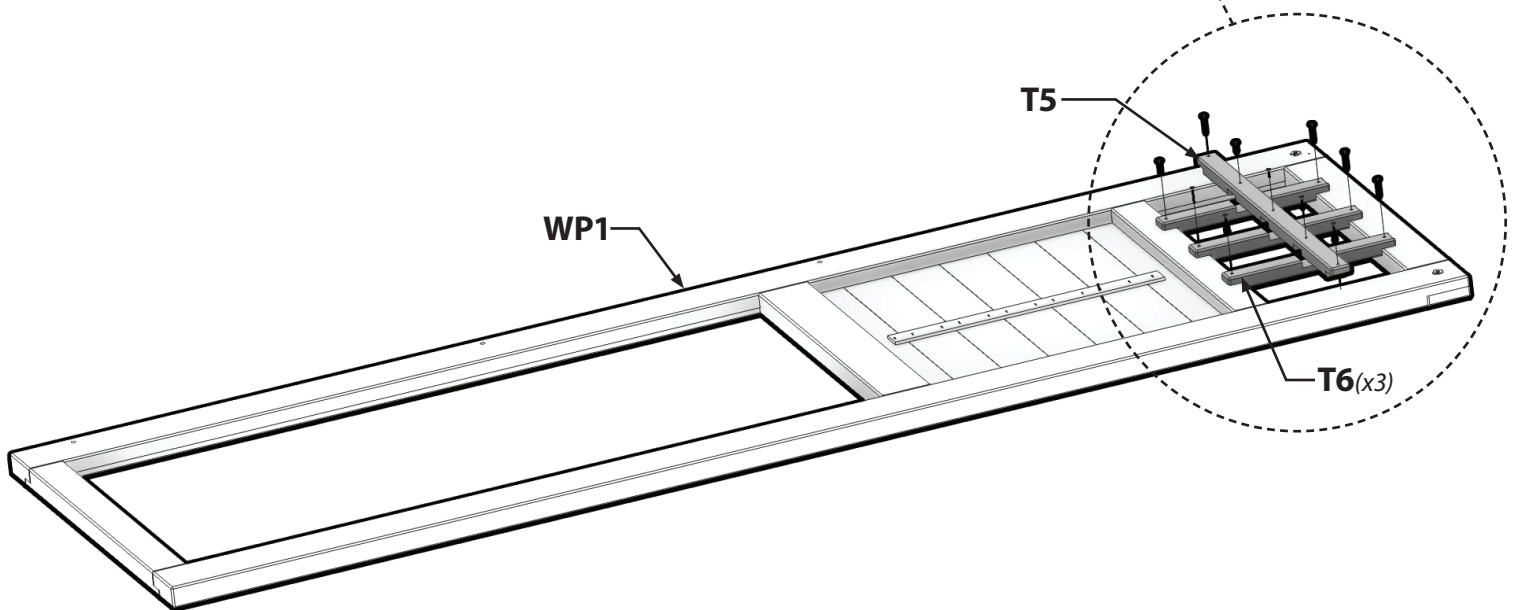
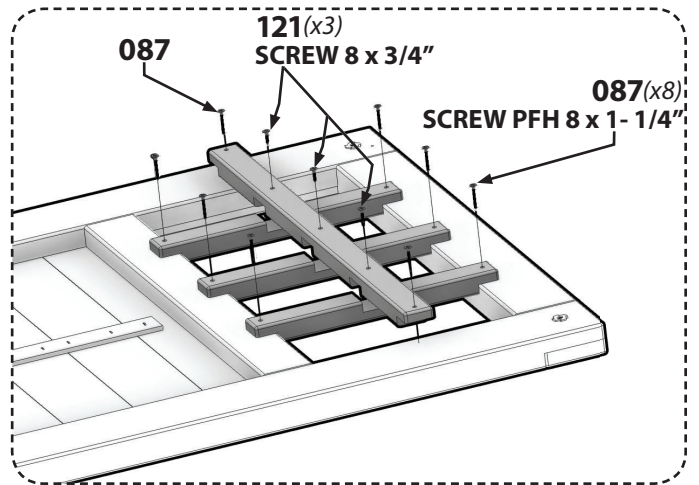



# Phase 3

## STEP 2

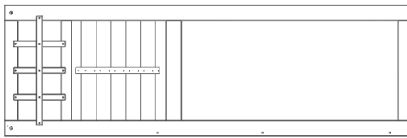

**WP1 ASSEMBLY**  
(x1)

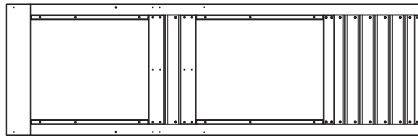

**WP4** | WALL PANEL - W2A02770  
(x1) 1-7/16" x 28-1/16" x 89-1/2" (36 x 712 x 2274)



**A4M00855** | LBRACKET 51X32X82X3.125  
(x2) A4M00855



**H100398** | T-NUT BLK  
(x2) 1/4 - H100398



**H100405** | WASHER LOCK EXT BLK  
(x3) 6x15 - H100405

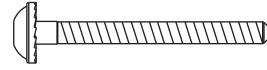

**H100456** | LAG SCREW WH BLK  
(x3) 1/4x2-1/2 - H100456

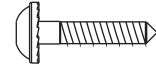

**H100568** | LAG SCREW WH BLK  
(x5) 1/4x1-1/4 - H100568



### ASSEMBLY TIP:

ASSEMBLE L-BRACKETS FIRST AND T-NUTS TO 'WP4'. ONLY FINGER TIGHTEN SCREWS AT THIS TIME.

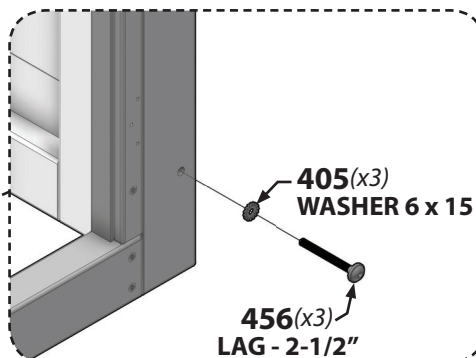
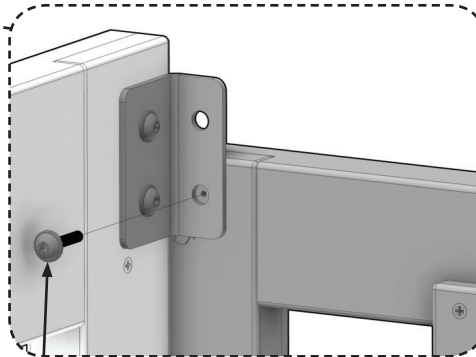
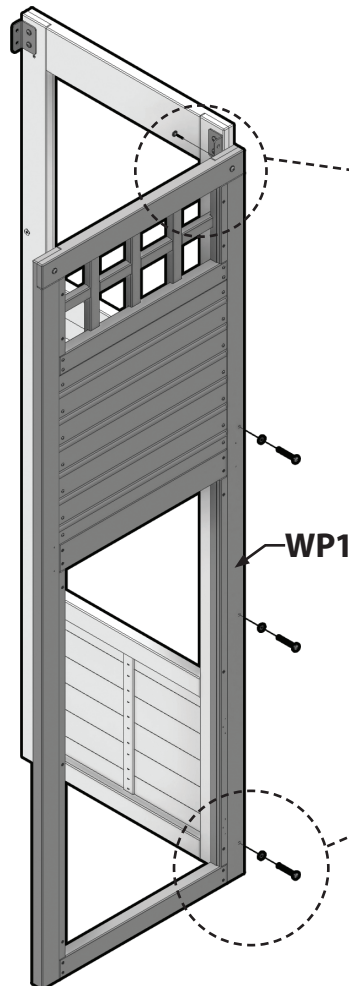
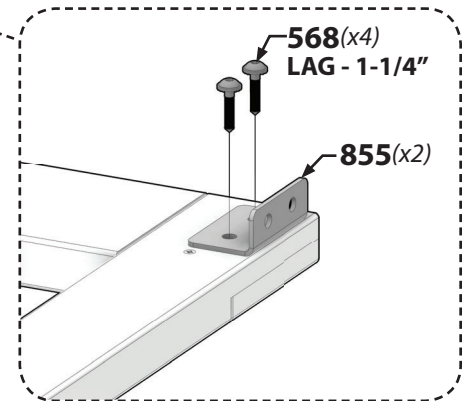
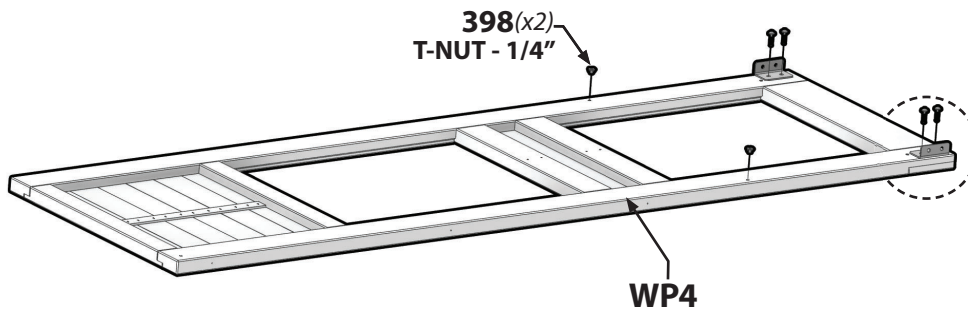
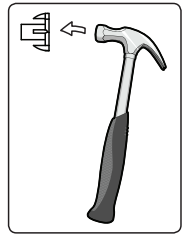



# Phase 3

# STEP 3

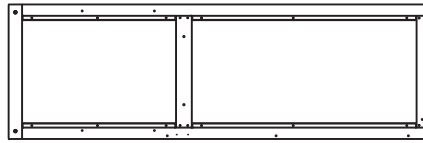

**WP9** | WALL PANEL - W2A02776  
(x1) | 1-7/16" x 28-1/16" x 87-3/16" (36 x 712 x 2214)

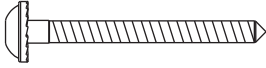

**H100456** | LAG SCREW WH BLK  
(x3) | 1/4x2-1/2 - H100456

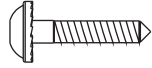

**H100568** | LAG SCREW WH BLK  
(x1) | 1/4x1-1/4 - H100568



**H100405** | WASHER LOCK EXT BLK  
(x3) | 6x15 - H100405



**H100398** | T-NUT BLK  
(x5) | 1/4 - H100398

**ASSEMBLY TIP:**  
ASSEMBLE T-NUTS FIRST  
TO 'WP9'.

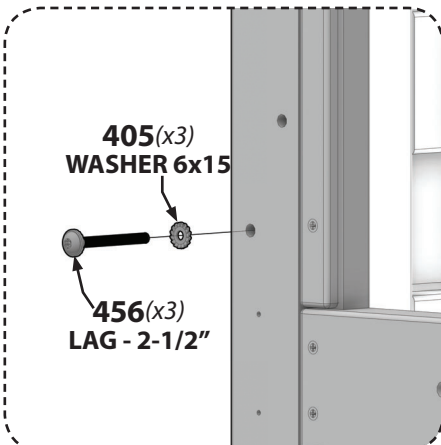
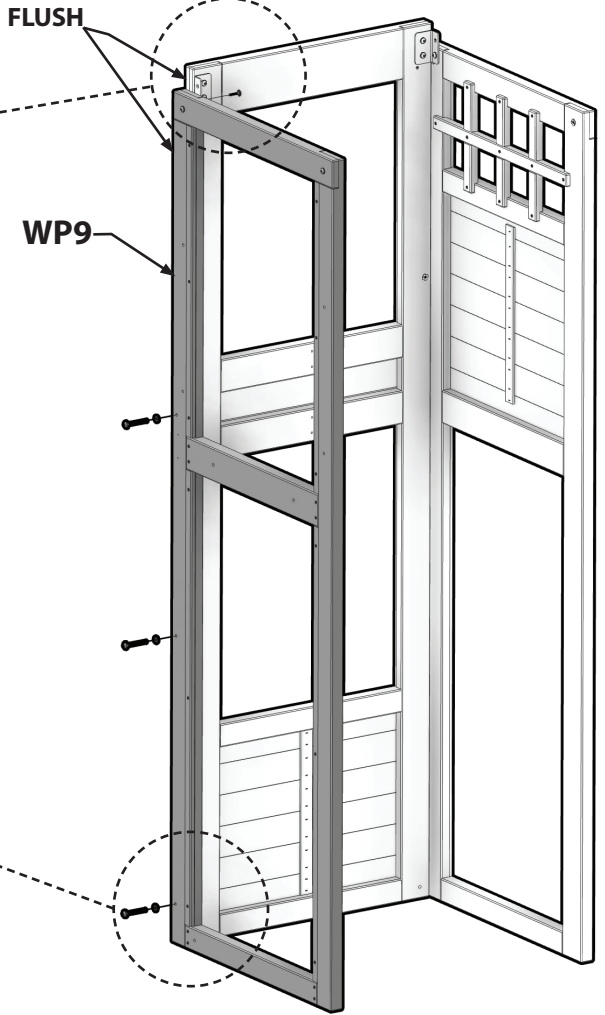
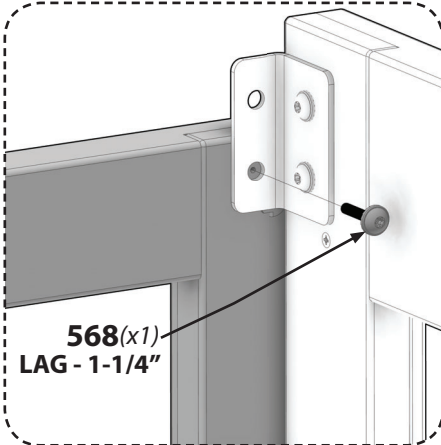
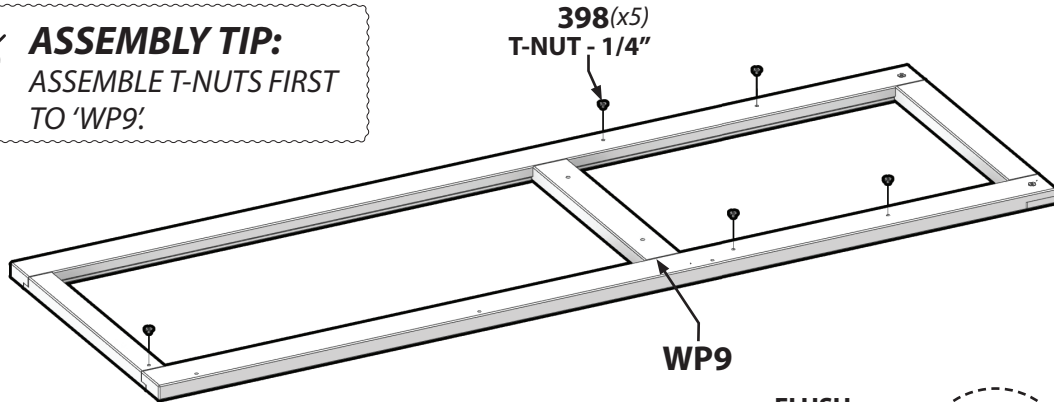



# Phase 3

# STEP 4

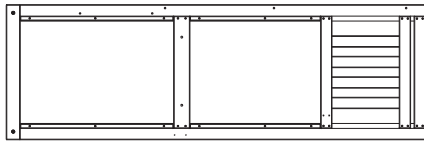

**WP10** | WALL PANEL - W2A02783  
(x1) | 1-9/16" x 28-1/16" x 87-3/16" (40 x 712 x 2214)

**H14** | FLOOR BRACE - W4L12478  
(x1) | 1" x 3-3/8" x 6-3/4" (24 x 86 x 170)

**J9** | BRACE - W4L12479  
(x1) | 1" x 2-3/8" x 30-1/8" (24 x 60 x 765)



**A4M00995** | METAL CLEAT  
(x1) | A4M00995



**H100089** | SCREW PFH  
(x10) | 8x1-3/4 - H100089



**H100202** | SCREW PWH BLK  
(x2) | 8x5/8 - H100202



**H100398** | T-NUT BLK  
(x2) | 1/4 - H100398

**ASSEMBLY TIP:**  
ASSEMBLE T-NUTS FIRST  
TO 'WP10'.

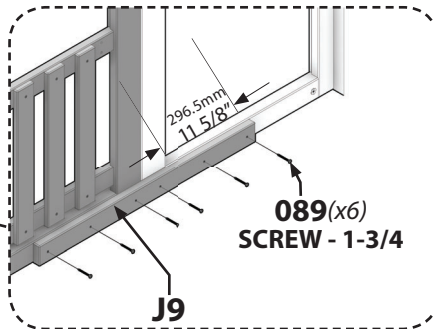
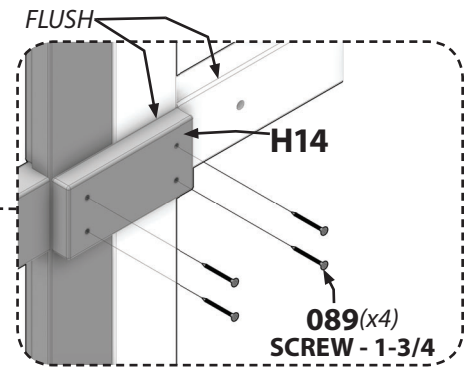
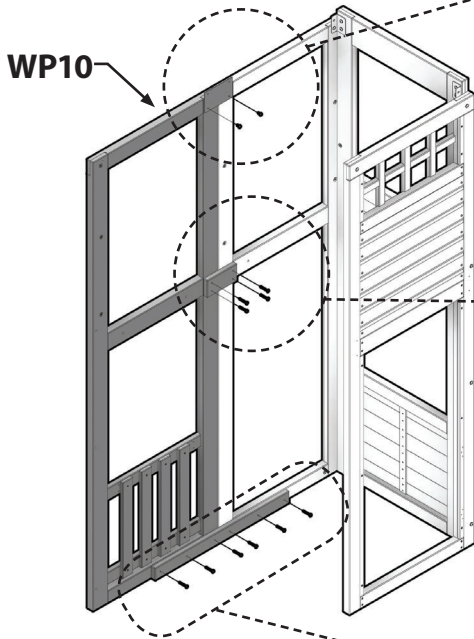
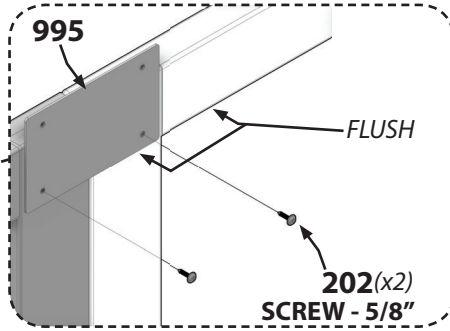
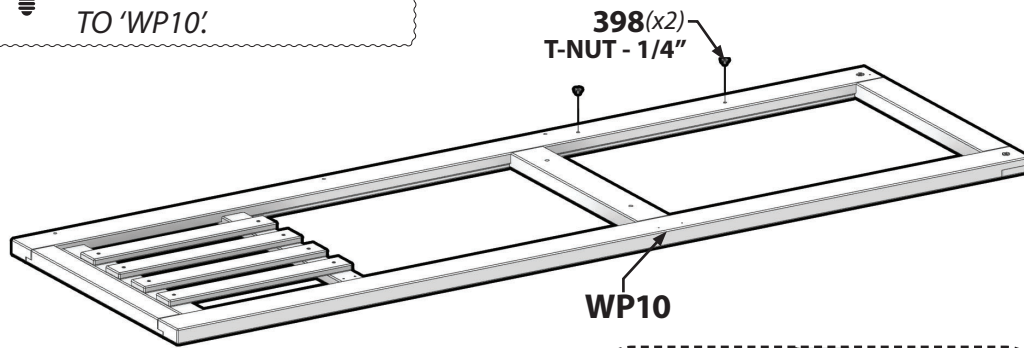
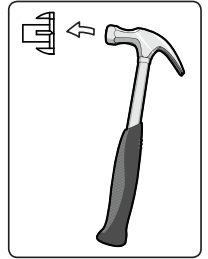



# Phase 3

# STEP 5

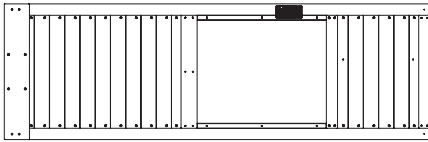

**WP7** | WALL PANEL - W2A02774  
(x1) 1-7/16" x 28-1/16" x 89-1/2" (36 x 712 x 2274)

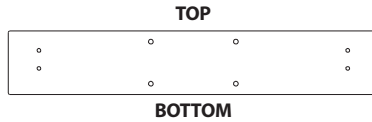

**G2** | RAIL - W4L12485  
(x1) 1" x 5-1/4" x 30-7/8" (24 x 134 x 784)

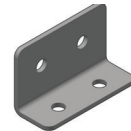

**A4M00855** | L BRACKET 51X32X82X3.125  
(x2) A4M00855



**H100379** | T-NUT BLK  
(x4) 5/16" - H100379



**H100399** | NUT BARREL WH BLK  
(x4) 1/4 x 7/8 - H100399



**H100400** | WASHER LOCK EXT BLK  
(x4) 8 x 15 - H100400

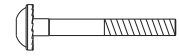

**H100488** | BOLT WH BLK  
(x4) 1/4 x 2 - H100488

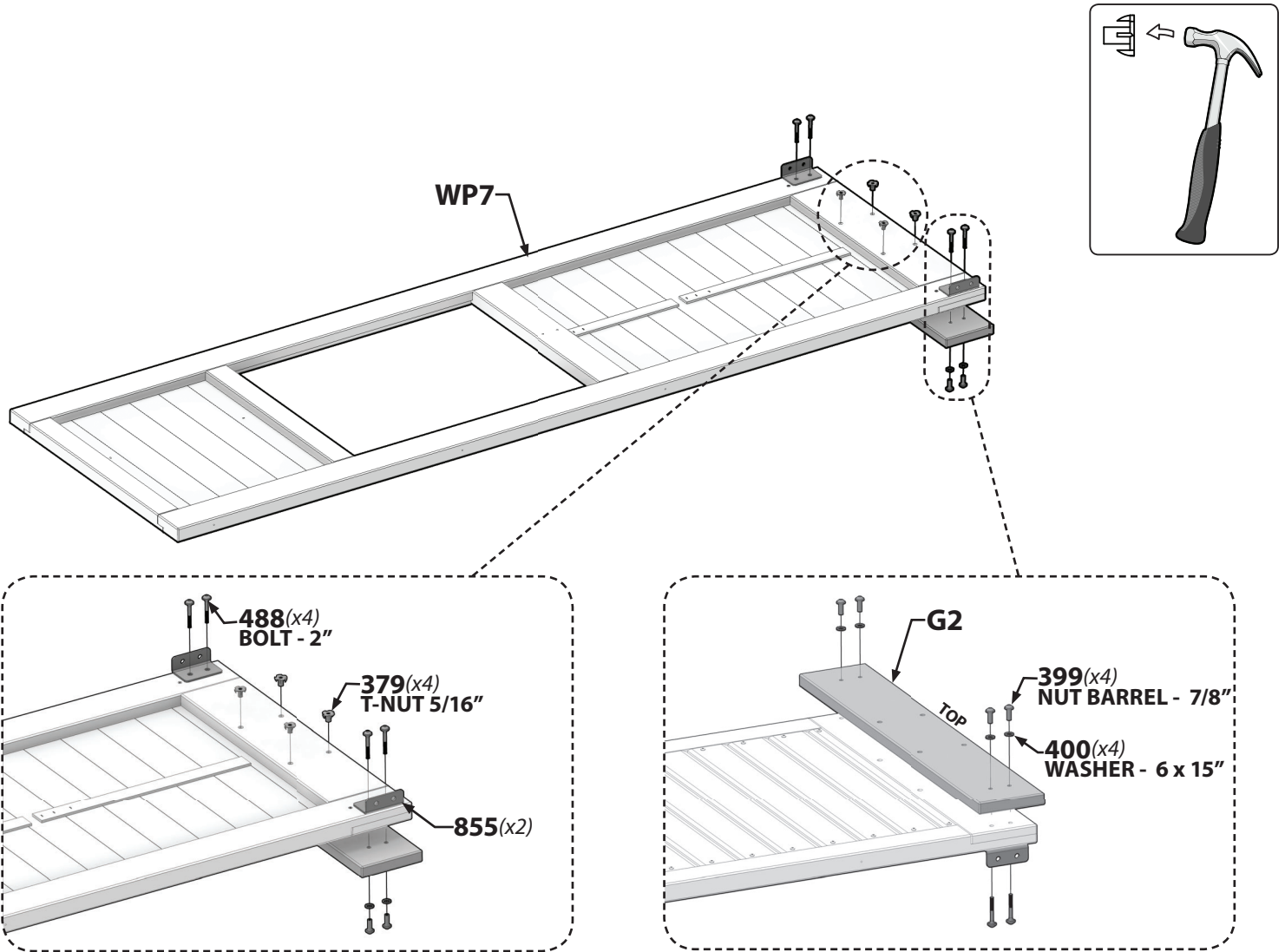

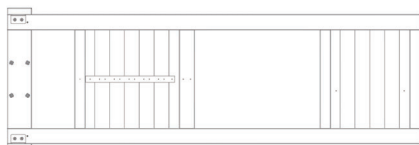

**WP7** | **WALL PANEL SUB-ASSEMBLY**  
(x1) 1-7/16" x 28-1/16" x 89-1/2" (36 x 712 x 2274)

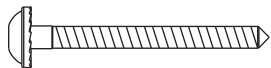

**H100456** | **LAG SCREW WH BLK**  
(x3) 1/4x2-1/2 - H100456



**H100568** | **LAG SCREW WH BLK**  
(x1) 1/4x1-1/4 - H100568



**H100405** | **WASHER LOCK EXT BLK**  
(x3) 6x15 - H100405

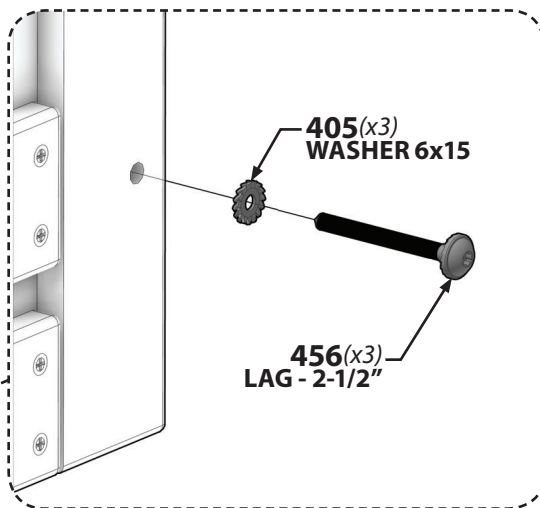
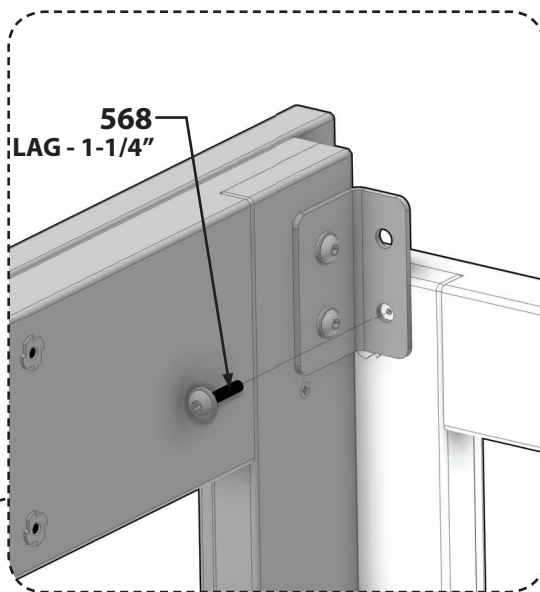
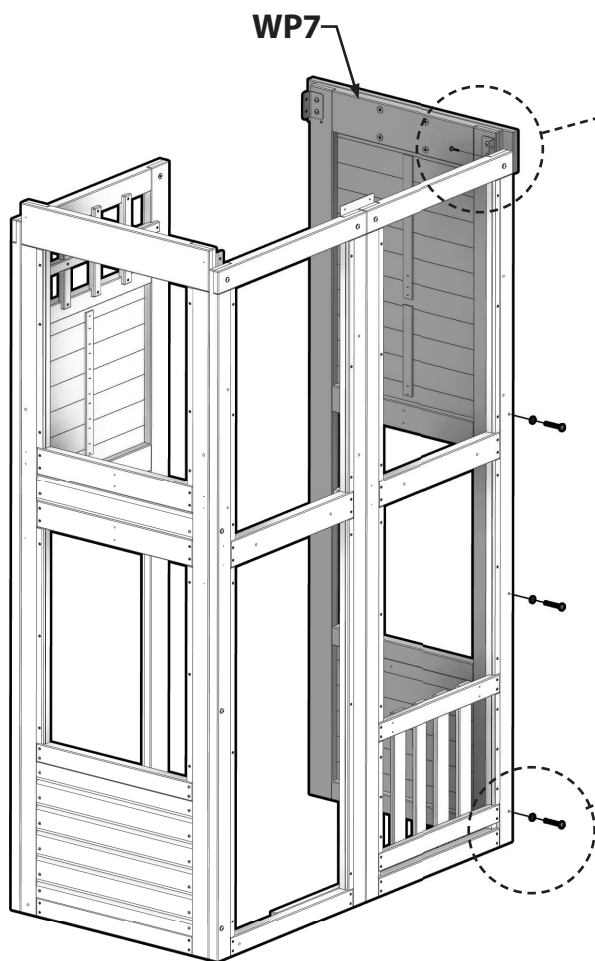

# Phase 3

# STEP 7

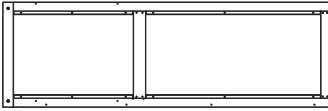

**WP2** | **WALL PANEL - W2A02768**  
(x1) 1-7/16" x 28-1/16" x 87-3/16" (36 x 712 x 2214)

**H14** | **FLOOR BRACE - W4L12478**  
(x1) 1" x 3-3/8" x 6-3/4" (24 x 86 x 170)

**J9** | **BRACE - W4L12479**  
(x1) 1" x 2-3/8" x 30-1/8" (24 x 60 x 765)

**A4M00995** | **METAL CLEAT**  
(x1) A4M00995

**H100089** | **SCREW PFH**  
(x10) 8x1-3/4 - H100089

**H100405** | **WASHER LOCK EXT BLK**  
(x3) 6x15 - H100405

**H100202** | **SCREW PWH BLK**  
(x2) 8x5/8 - H100202

**H100456** | **LAG SCREW WH BLK**  
(x3) 1/4x2-1/2 - H100456

**H100398** | **T-NUT BLK**  
(x4) 1/4 - H100398

**H100568** | **LAG SCREW WH BLK**  
(x1) 1/4x1-1/4 - H100568

**ASSEMBLY NOTE:**  
ASSEMBLE T-NUTS FIRST TO 'WP2'.  
BE SURE TO TIGHTEN ALL PANEL  
HARDWARE AT THIS TIME.

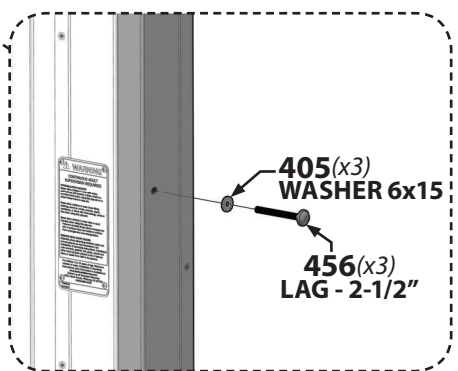
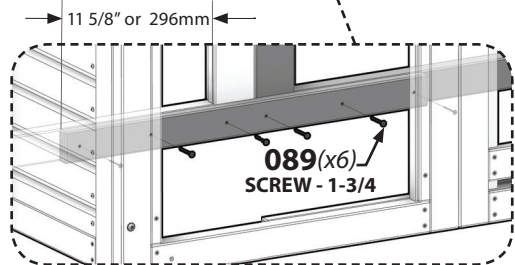
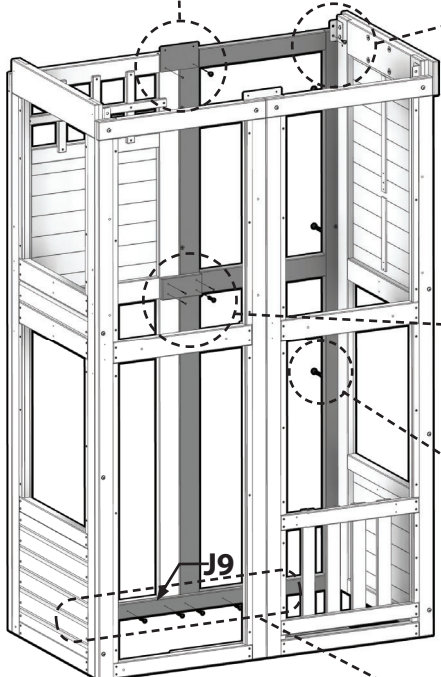
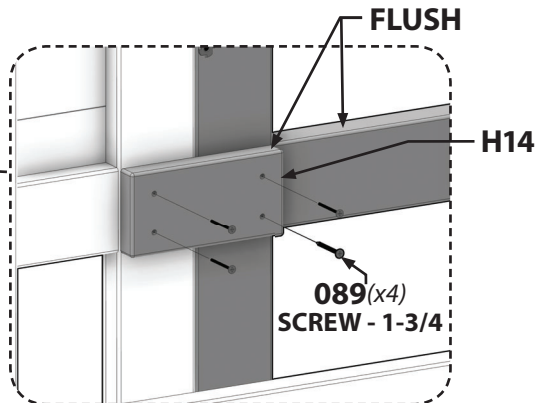
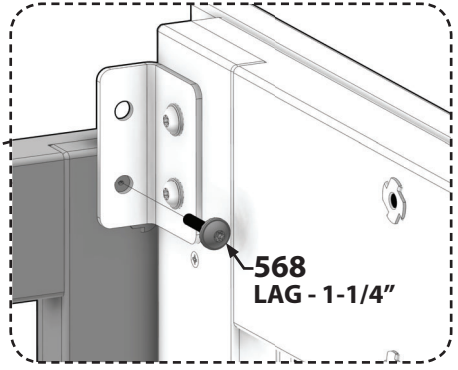
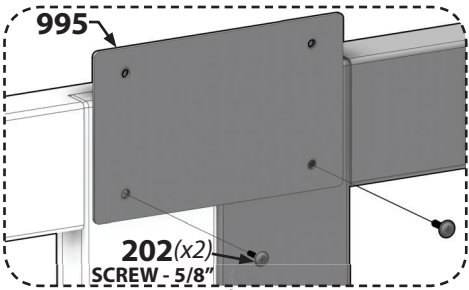
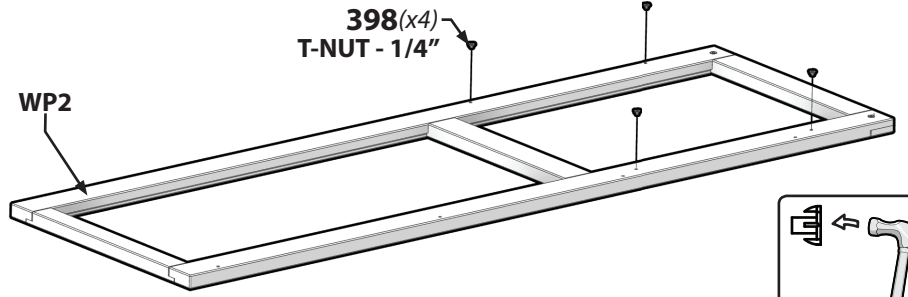



**H3** | FLOOR JOIST - W4L12345  
(x1) 1" x 3-3/8" x 53-1/4" (24x 86 x 1352)

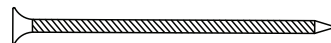

**H100092** | SCREW PFH  
(x4) 8x3 - H100092



**ASSEMBLY NOTE:**  
USE PILOT HOLES AS GUIDE.

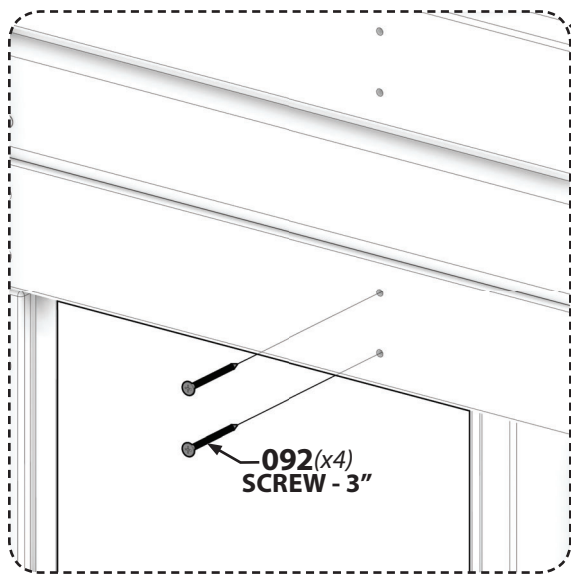
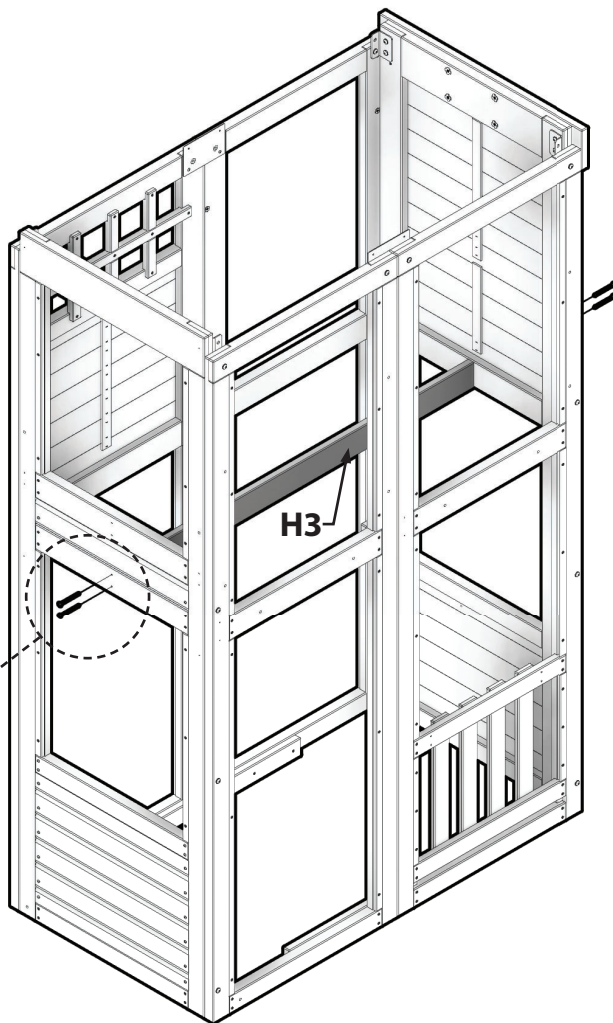



# Phase 3

# STEP 9

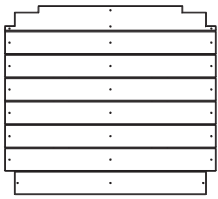

**FP3** | FLOOR PANEL - W2A02779  
(x1) | 1-1/4" x 27-3/4" x 30-7/8" (32 x 705 x 784)

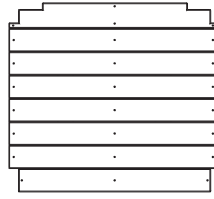

**FP4** | FLOOR PANEL - W2A02780  
(x1) | 1-1/4" x 27-1/2" x 30-3/8" (32 x 699 x 772)



**H100086** | SCREW PFH  
(x50) | 8x1-1/2 - H100086



**ASSEMBLY NOTE:**  
USE PILOT HOLES AS GUIDE.  
NOTE PANEL ORIENTATION.

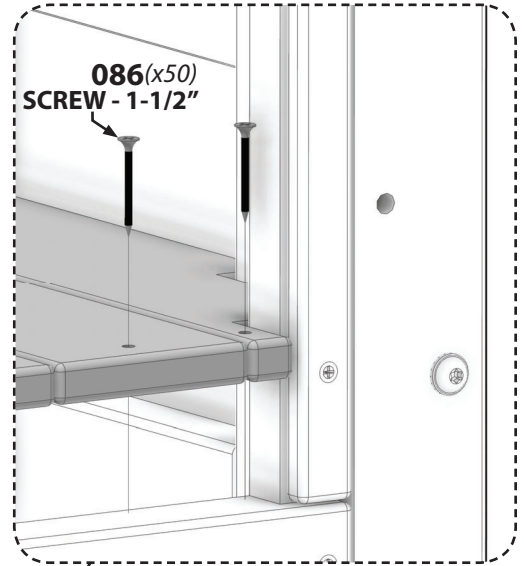
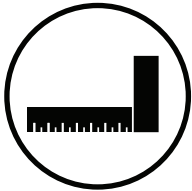

**PUSH TOGETHER**

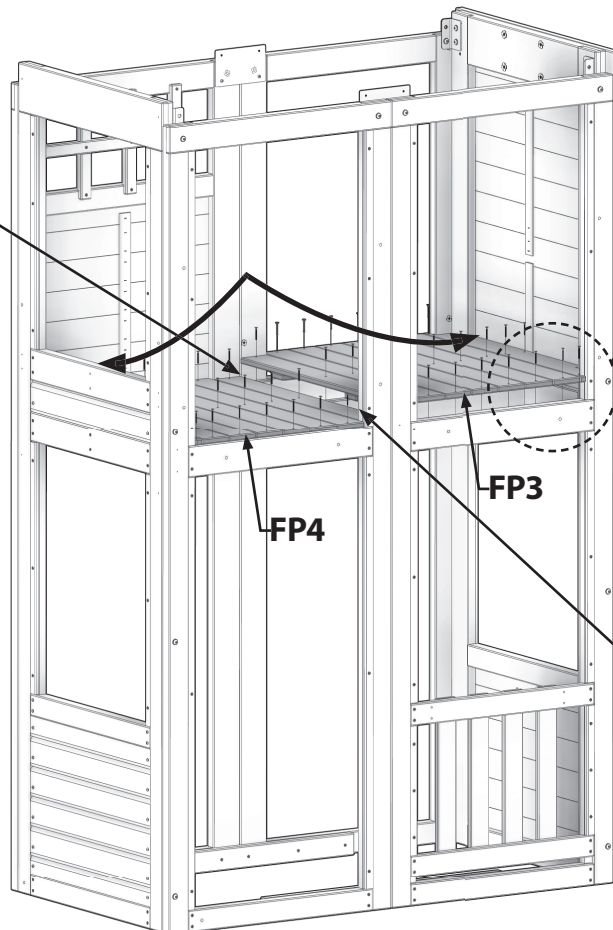

**ASSEMBLY TIP:**  
POSITION 'FP3' AND 'FP4' PANELS  
AT A 45 DEGREE ANGLE THEN  
PUSH DOWN INTO PLACE.

**PUSH TOGETHER**



# Phase 3

# STEP 10



ROCKWALL ASSEMBLY

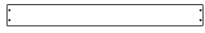

**M74** | ROCK BOARD - W4L11757  
(x1) | 5/8" x 3-3/8" x 31-1/4" (16 x 86 x 794)



**M76** | ROCK BOARD SUB-ASSEMBLY - W4L11759  
(x1) | 5/8" x 3-3/8" x 31-1/4" (16 x 86 x 794)



**H100086** | SCREW PFH  
(x8) | 8x1-1/2 - H100086



**H100200** | SCREW PFH BLK  
(x2) | 8x1-1/2 - H100200



**H100398** | T-NUT BLK  
(x4) | 1/4 - H100398



**H100405** | WASHER LOCK EXT BLK  
(x4) | 6x15 - H100405

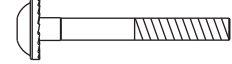

**H100488** | BOLT WH BLK  
(x4) | 1/4x2 - H100488

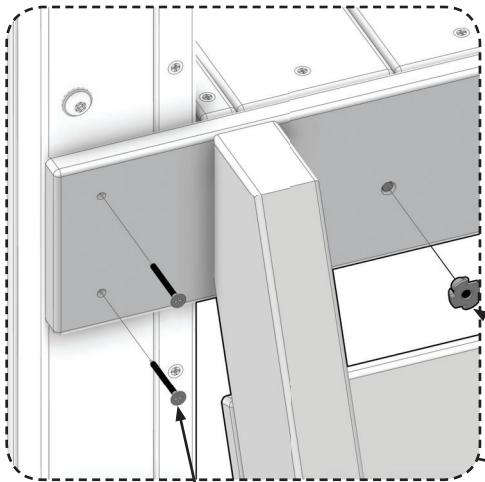
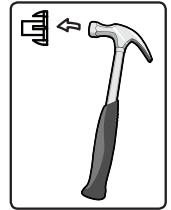

**398(x4)**  
T-NUT - 1/4"

**200(x2)**  
SCREW - 1-1/2

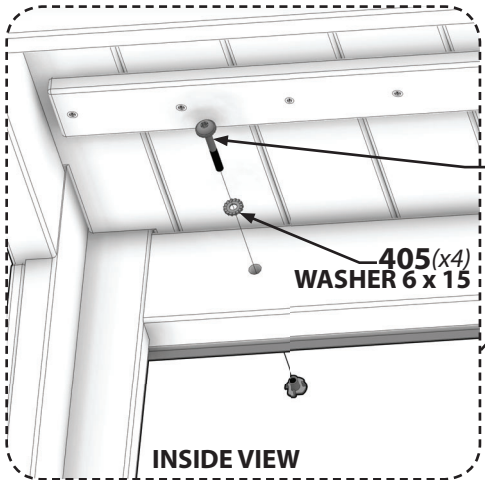

**488(x4)**  
BOLT - 2"

**405(x4)**  
WASHER 6 x 15

INSIDE VIEW

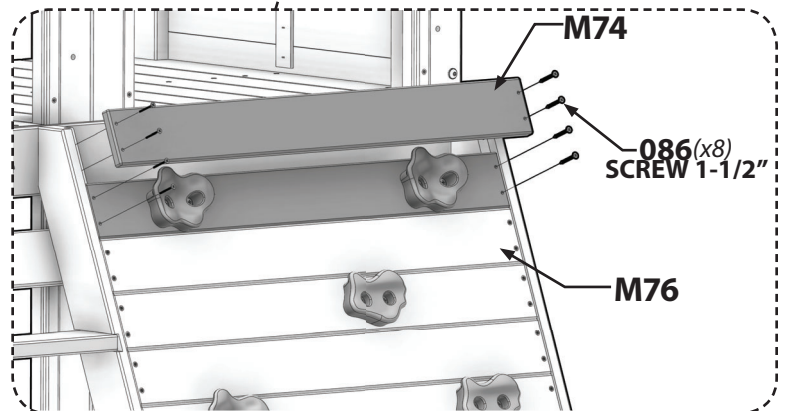
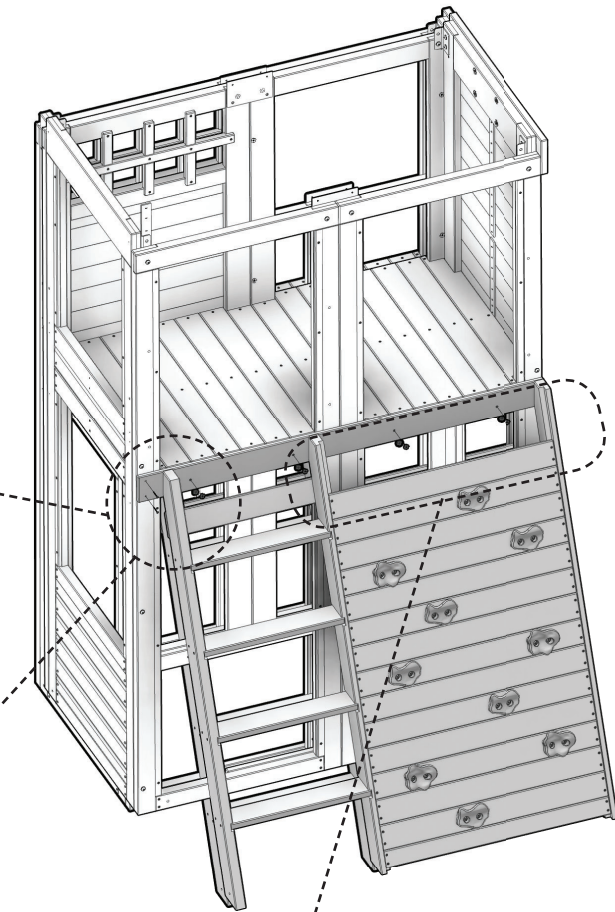

**M74**

**086(x8)**  
SCREW 1-1/2"

**M76**



### ASSEMBLY NOTE:

PLACE 'M74' & 'M76' ROCK BOARDS FROM PHASE 2 - STEP 3 TO FINISH ASSEMBLY OF ROCK WALL.



**F4** | **GROUND BOARD - W4L12487**  
 (x1) | 1-3/8" x 2-3/8" x 74-1/8" (36 x 60 x 1883)

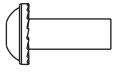

**H100399** | **NUT BARREL WH BLK**  
 (x1) | 1/4 x 7/8 - H100399



**H100400** | **WASHER LOCK EXT BLK**  
 (x1) | 8 x 15 - H100400



**H100405** | **WASHER LOCK EXT BLK**  
 (x3) | 6 x 15 - H100405

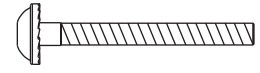

**H100567** | **BOLT WH BLK**  
 (x1) | 1/4 x 2-1/4 - H100567

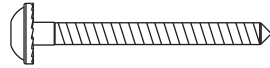

**H100456** | **LAG SCREW WH BLK**  
 (x2) | 1/4 x 2-1/2 - H100456

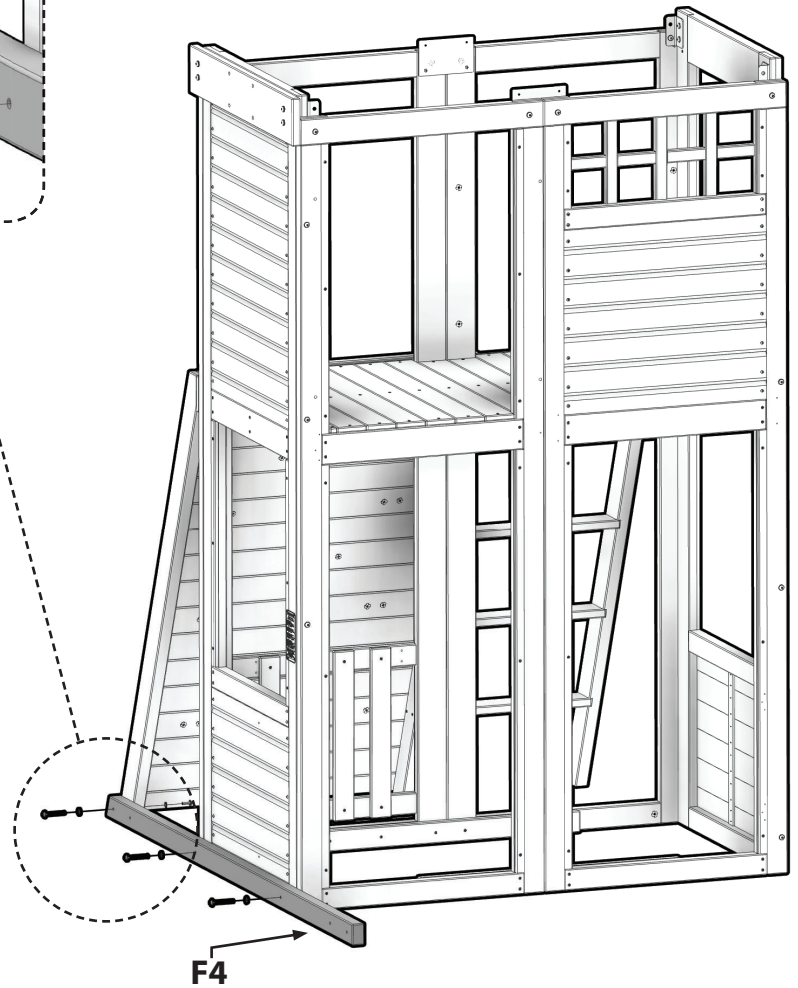
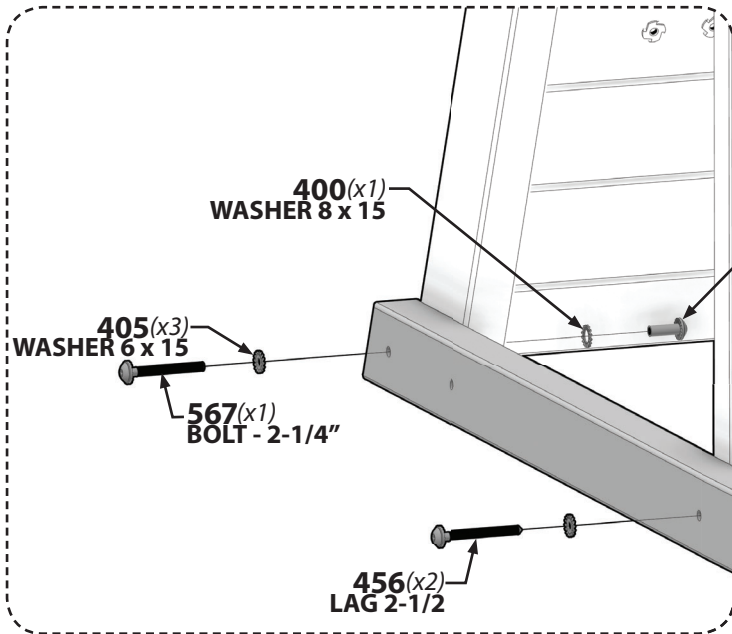



# Phase 3

# STEP 12



**F5** | **GROUND BOARD - W4L12488**  
(x1) 1-3/8" x 2-3/8" x 24-1/4" (36 x 60 x 617)



**A4M00710** | **L BRACKET BLACK 32X51**  
(x1) A4M00710

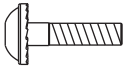

**H100171** | **BOLT WH BLK**  
(x1) 1/4x1 - H100171

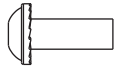

**H100399** | **NUT BARREL WH BLK**  
(x2) 1/4 x 7/8 - H100399



**H100400** | **WASHER LOCK EXT BLK**  
(x2) 8 x 15 - H100400



**H100405** | **WASHER LOCK EXT BLK**  
(x1) 6 x 15 - H100405

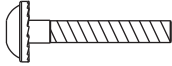

**H100406** | **BOLT WH BLK**  
(x1) 1/4x1-1/2 - H100406

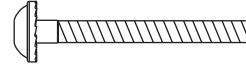

**H100567** | **BOLT WH BLK**  
(x1) 1/4x2-1/4 - H100567

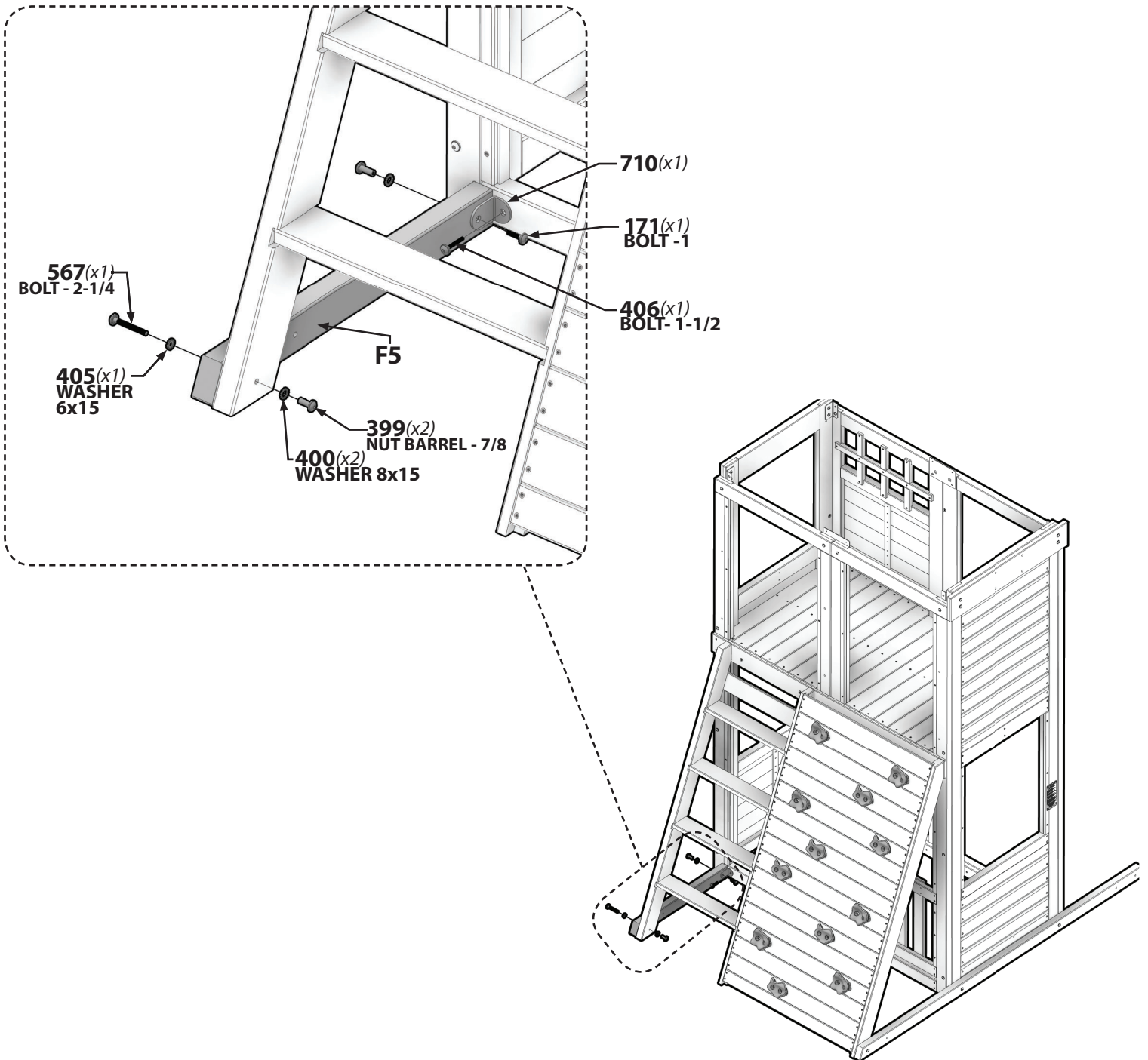

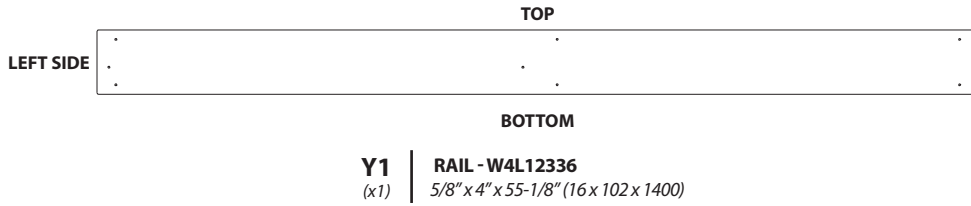

**H100200** | **SCREW PFH BLK**  
(x6) | 8x1-1/2 - H100200



### ASSEMBLY NOTE:

USE PILOT HOLES AS GUIDE.  
NOTE BOARD ORIENTATION.

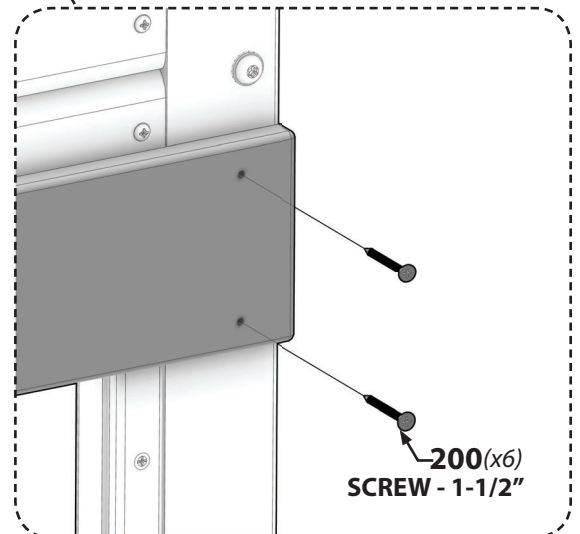
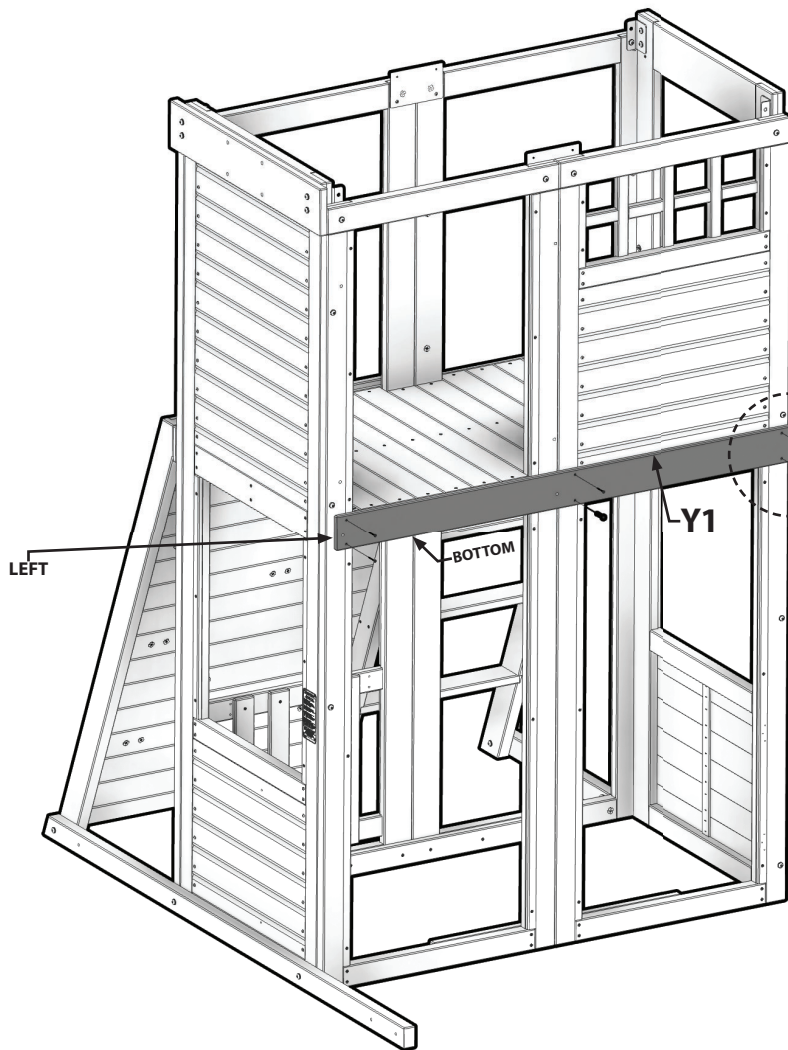



# Phase 4

## STEP 1

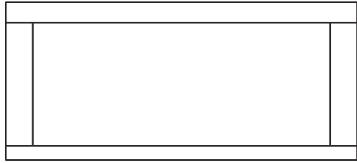

**WP3** | FRONT WINDOW FRAME - W2A02769  
(x1) 1-7/16" x 25-3/16" x 56-1/16" (36 x 640 x 1424)

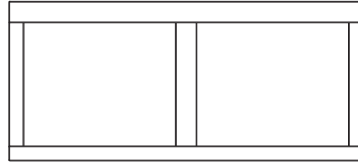

**WP6** | REAR WINDOW FRAME - W2A02772  
(x1) 1-7/16" x 25-3/16" x 56-1/16" (36 x 640 x 1424)



**A6P00319** | ARCHED GABLE  
(x2) A6P00319



**H100785** | SCREW PWH  
(x16) 8x1 - H100785

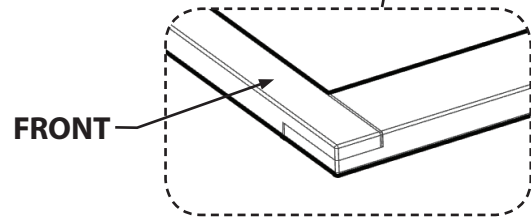
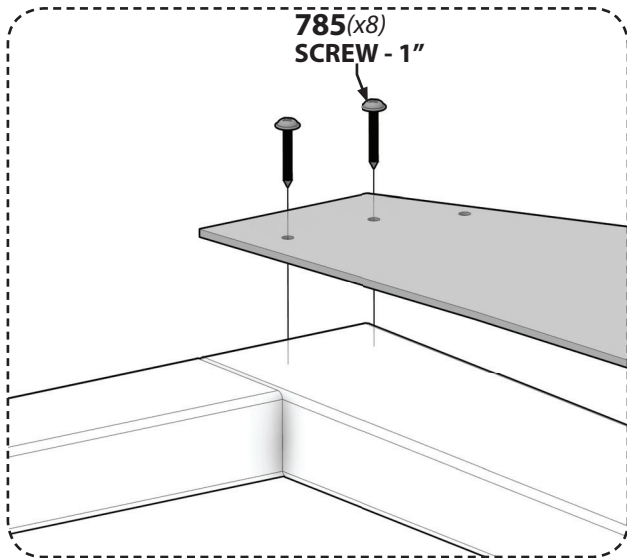
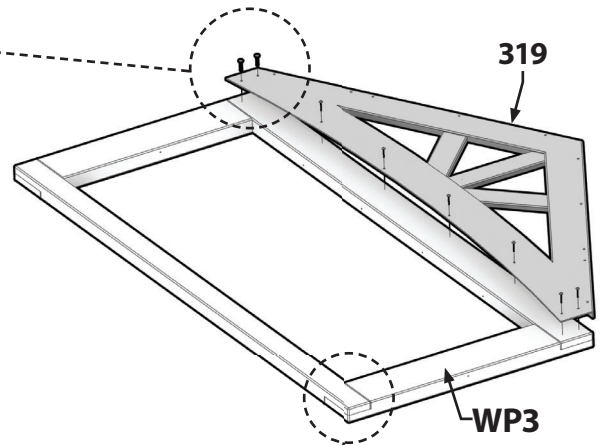
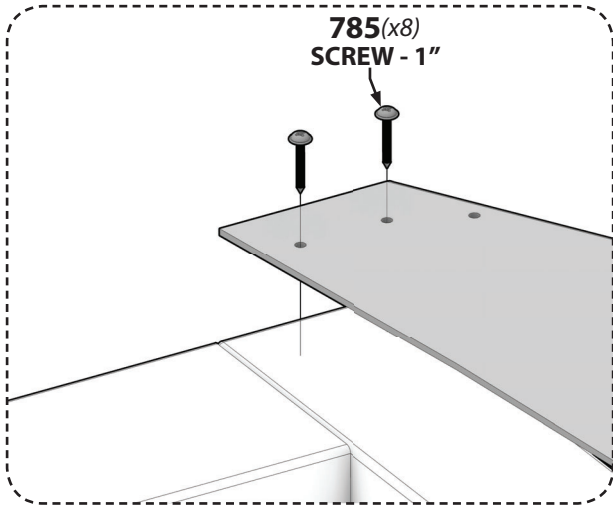

**ASSEMBLY TIP:**  
NOTE OVERLAP OF BOARDS TO DETERMINE THE FRONT OF BOTH PANELS.

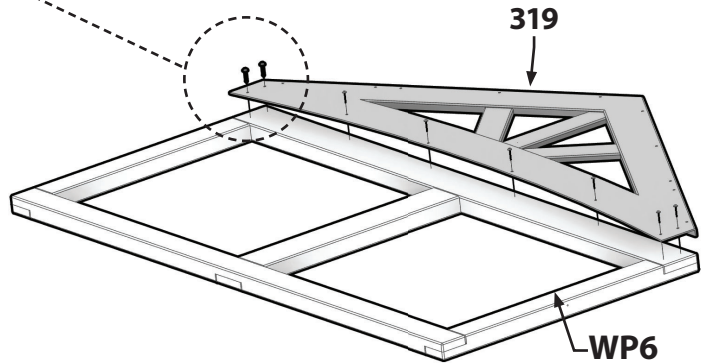



H100202 | SCREW PWH BLK  
(x4) | 8x5/8 - H100202

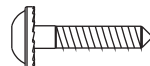

H100568 | LAG SCREW WH BLK  
(x4) | 1/4x1-1/4 - H100568

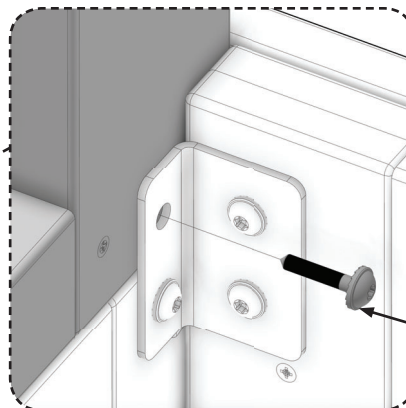
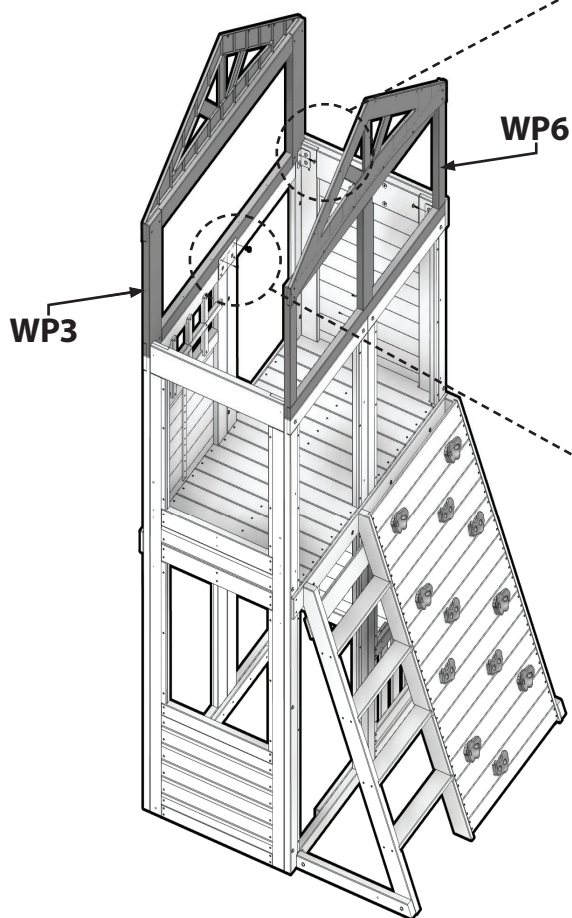

568(x4)  
SCREW - 1-1/4"



**ASSEMBLY NOTE:**  
REPEAT THIS STEP AT EACH INSIDE CORNER.

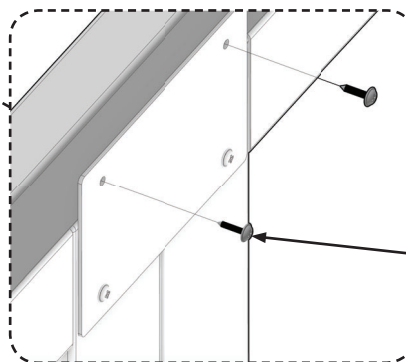

202(x4)  
SCREW - 5/8"



**ASSEMBLY NOTE:**  
REPEAT THIS STEP ON OPPOSITE SIDE.



**A6P00320** | **ARCHED SIDE**  
(x2) | A6P00320

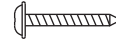

**H100785** | **SCREW PWH**  
(x12) | 8x1 - H100785



### ASSEMBLY NOTE:

REPEAT THIS STEP ON OPPOSITE SIDE.

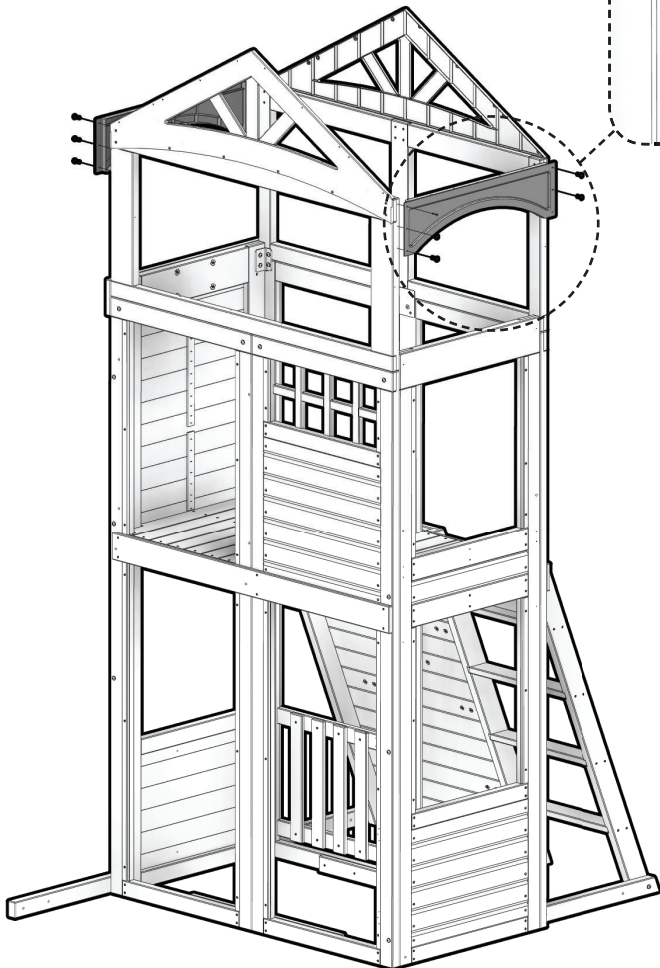
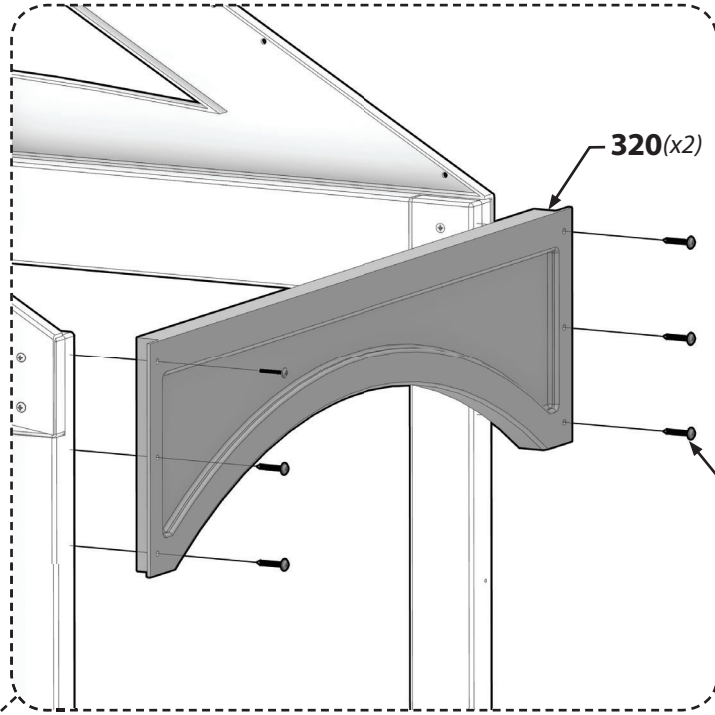



# Phase 4

# STEP 4

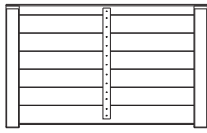

**RP1** | **ROOF PANEL - W2A02781**  
(x2) | 1-3/8" x 21-7/8" x 35-13/16" (35 x 556 x 910)

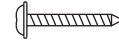

**H100785** | **SCREW PWH**  
(x12) | 8 x 1 - H100785

**785(x12)**  
**SCREW - 1"**

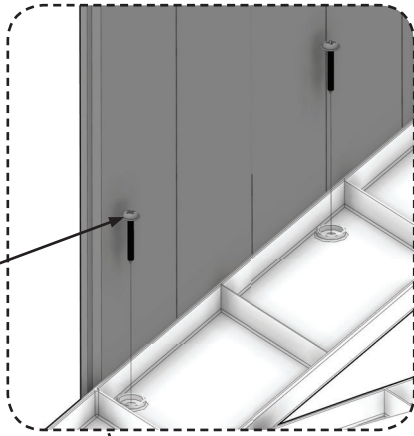

**ASSEMBLY NOTE:**  
FASTEN ROOF PANEL WITH SCREWS ON BOTH SIDE.

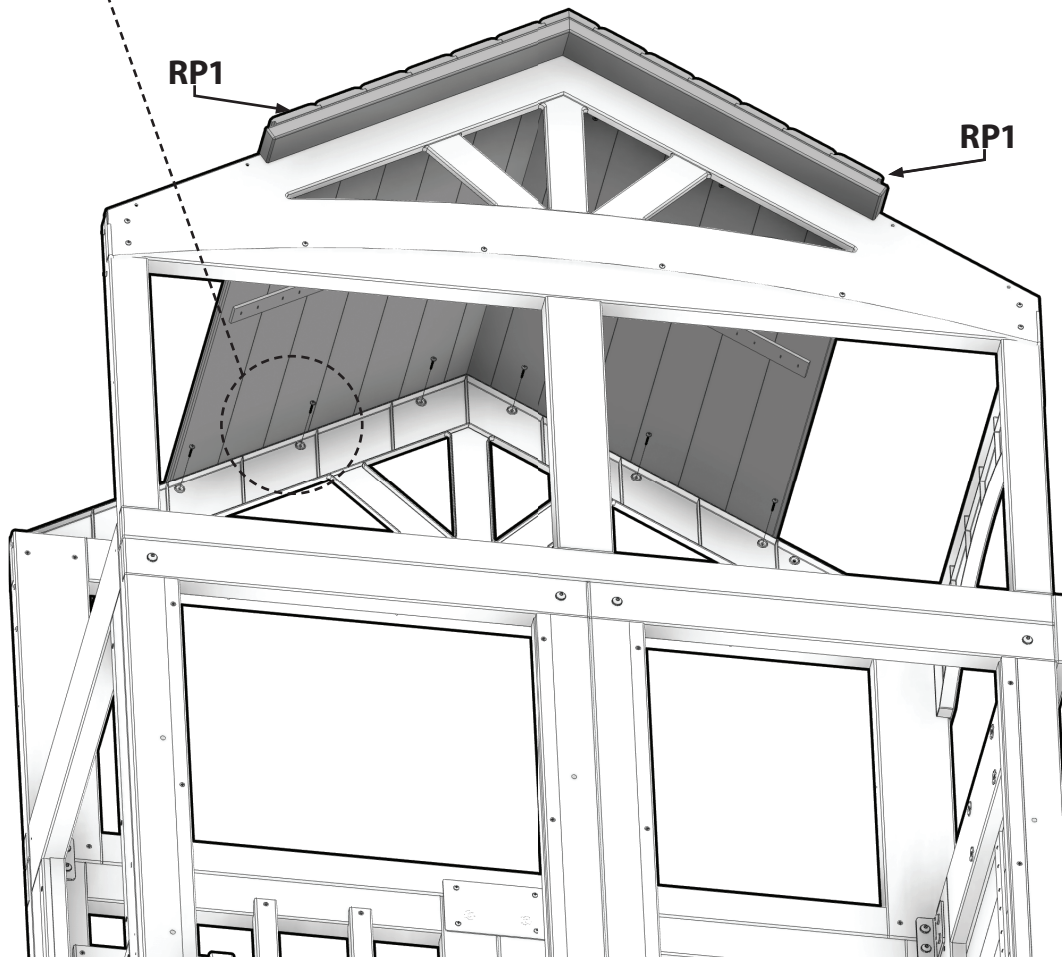



# Phase 4

# STEP 5

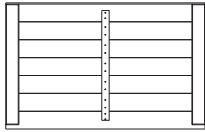

**RP2** | **ROOF PANEL - W2A02782**  
(x2) | 1-3/8" x 22-5/8" x 35-13/16" (35 x 575 x 910)

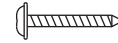

**H100785** | **SCREW PWH**  
(x8) | 8x1 - H100785



**ASSEMBLY NOTE:**  
FASTEN ROOF PANEL WITH SCREWS ON  
BOTH SIDE.

**785(x8)**  
**SCREW - 1"**

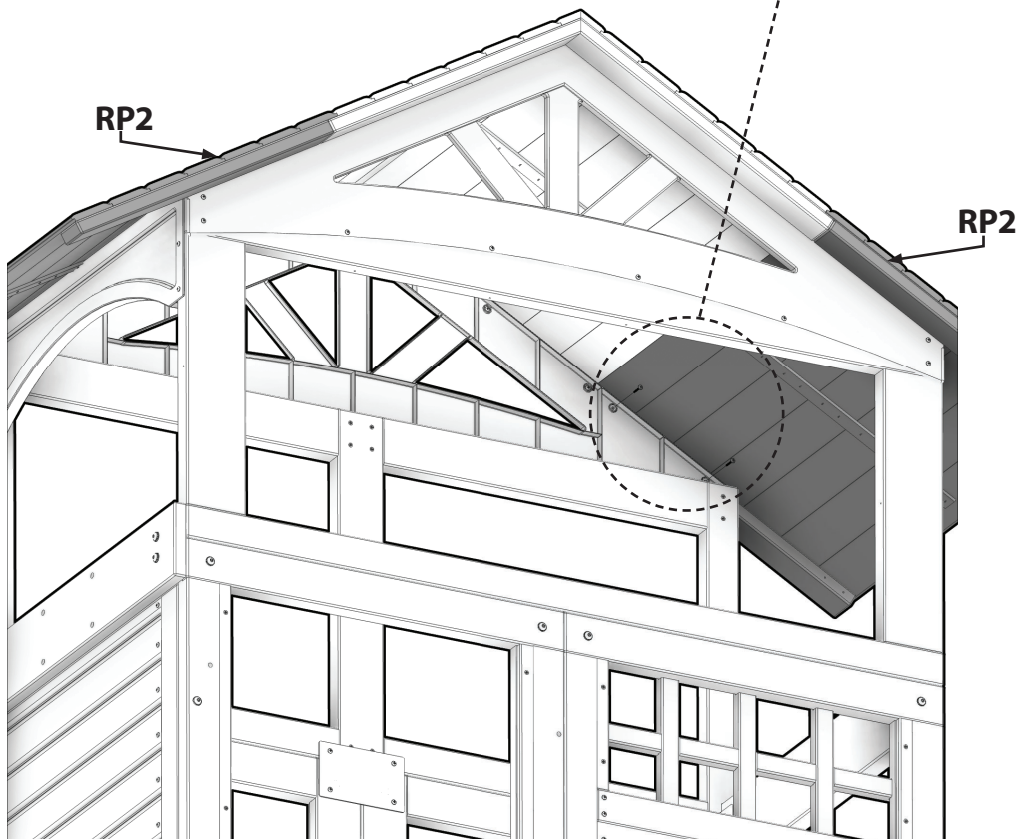
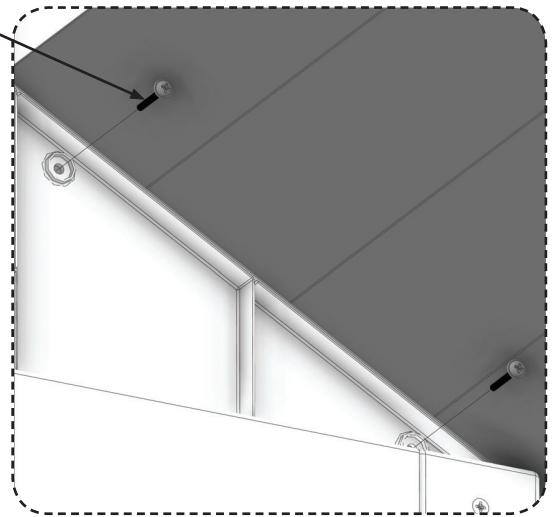



# Phase 4

# STEP 6

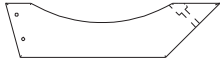

**H10** | ANGLE BRACE - W4L12333  
(x4) | 1" x 3-3/8" x 13-3/8" (24 x 86 x 340)

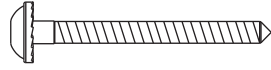

**H100456** | LAG SCREW WH BLK  
(x4) | 1/4" x 2-1/2" - H100456



**H100405** | WASHER LOCK EXT BLK  
(x4) | 6 x 15 - H100405



**H100090** | SCREW PFH  
(x8) | 8 x 2-1/2" - H100090

**090(x8)**  
SCREW - 2-1/2"

**456(x4)**  
LAG 2-1/2"

**405(x4)**  
WASHER 6x15



### ASSEMBLY NOTE:

REPEAT PROCESS 3 MORE TIMES TO FASTEN ANGLE BRACES.

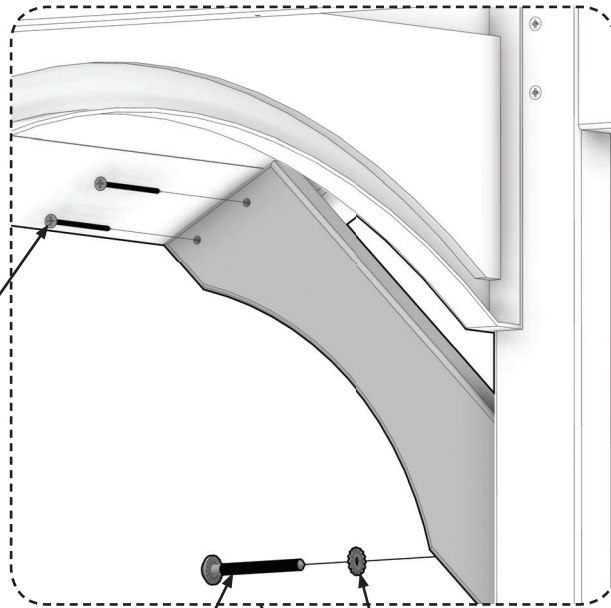

**H10(x4)**

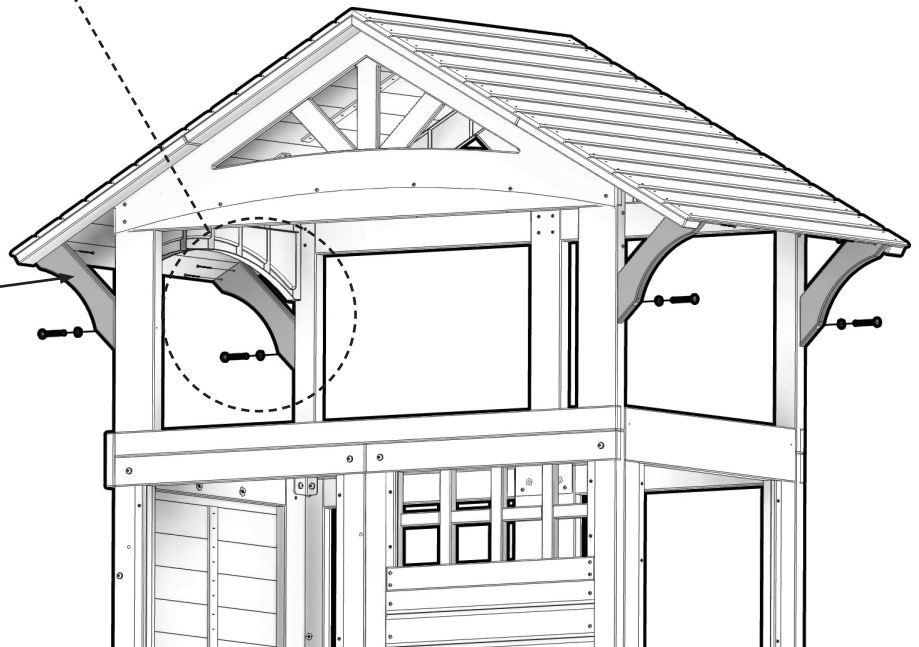



# Phase 4

# STEP 7

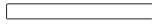

**J1** | **BAY WINDOW SIDE - W4L12333**  
(x2) | 1" x 1-7/8" x 18-1/4" (24 x 48 x 464)

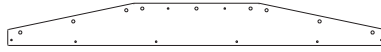

**K1** | **BAY WINDOW HEADER - W4L12332**  
(x2) | 5/8" x 5-1/4" x 7-1/4" (16 x 134 x 1199)

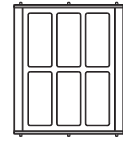

**A100373** | **BAY WINDOW PANEL**  
(x3) | A100373



**H100200** | **SCREW PFH BLK**  
(x4) | 8x1-1/2 - H100200



**H100385** | **SCREW PFH BLK**  
(x4) | 8x1 - H100385

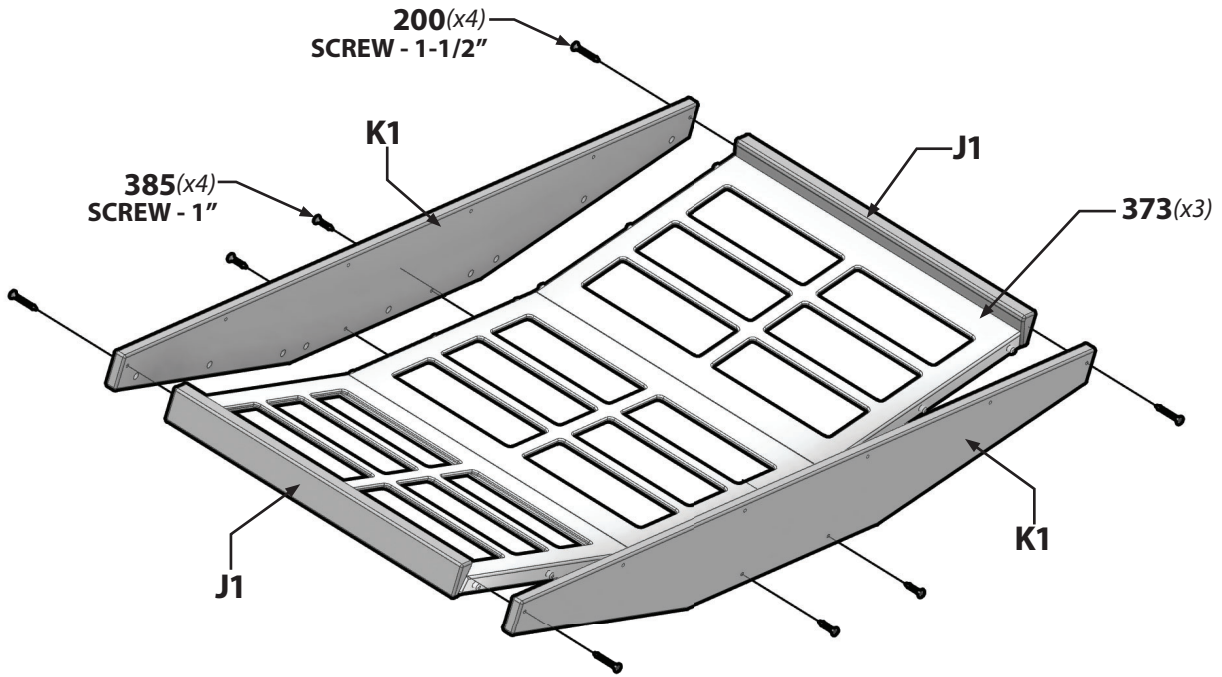

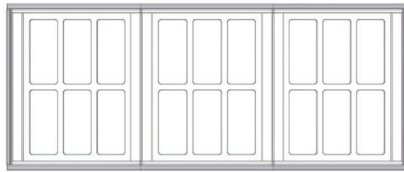

**BAY WINDOW ASSEMBLY**



**H100200**  
(x8)

**SCREW PFH BLK**  
8x1-1/2 - H100200

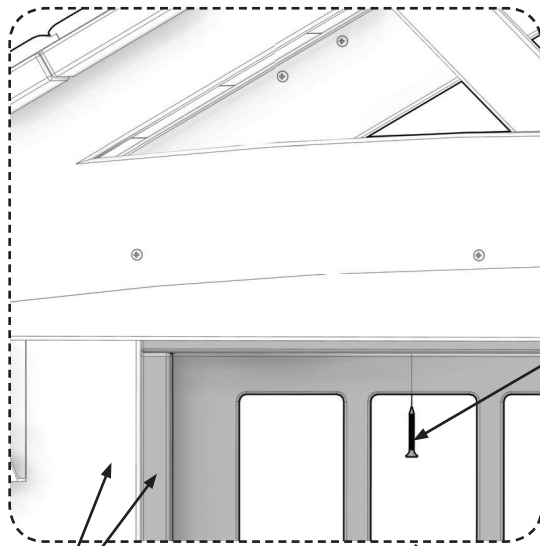

**200(x4)**  
**SCREW - 1-1/2"**

**FLUSH**

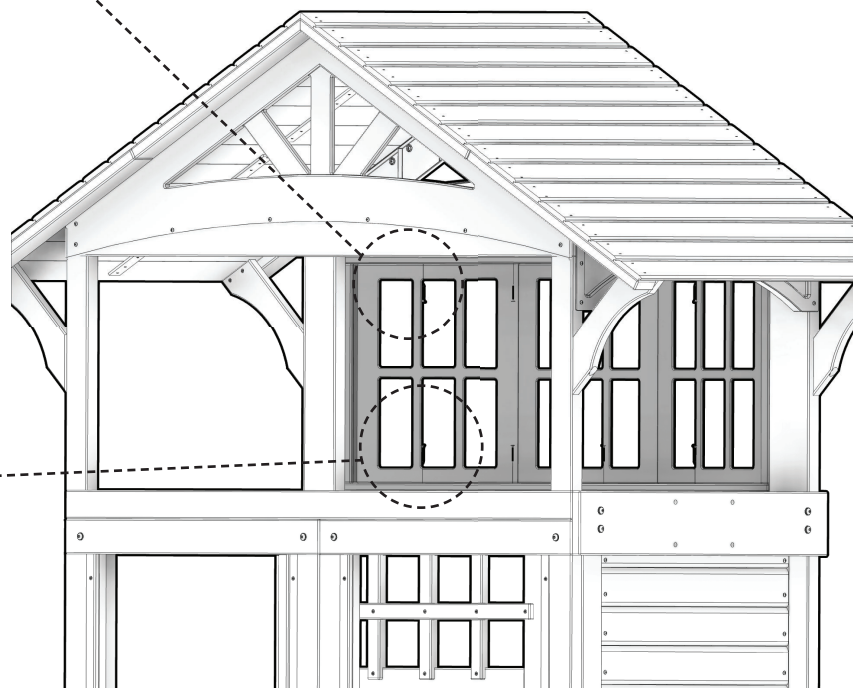
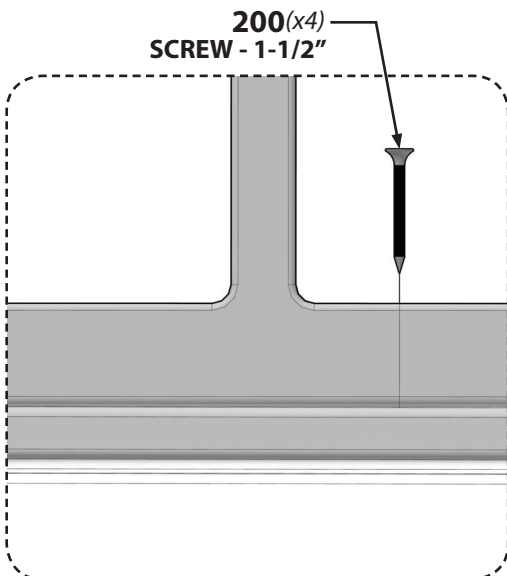

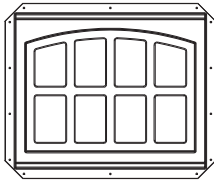

**A6P00321** | **ARCHED WINDOW**  
(x2) | A6P00321



**H100785** | **SCREW PWH**  
(x28) | 8x1 - H100785

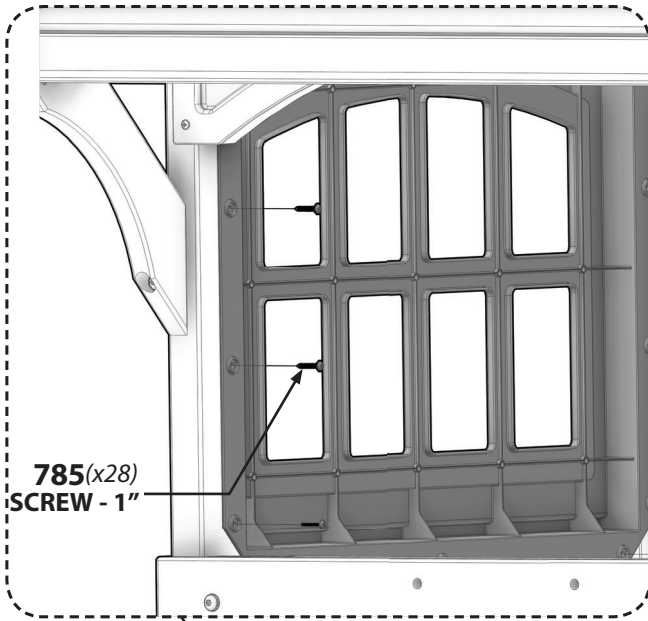

**321(x2)**

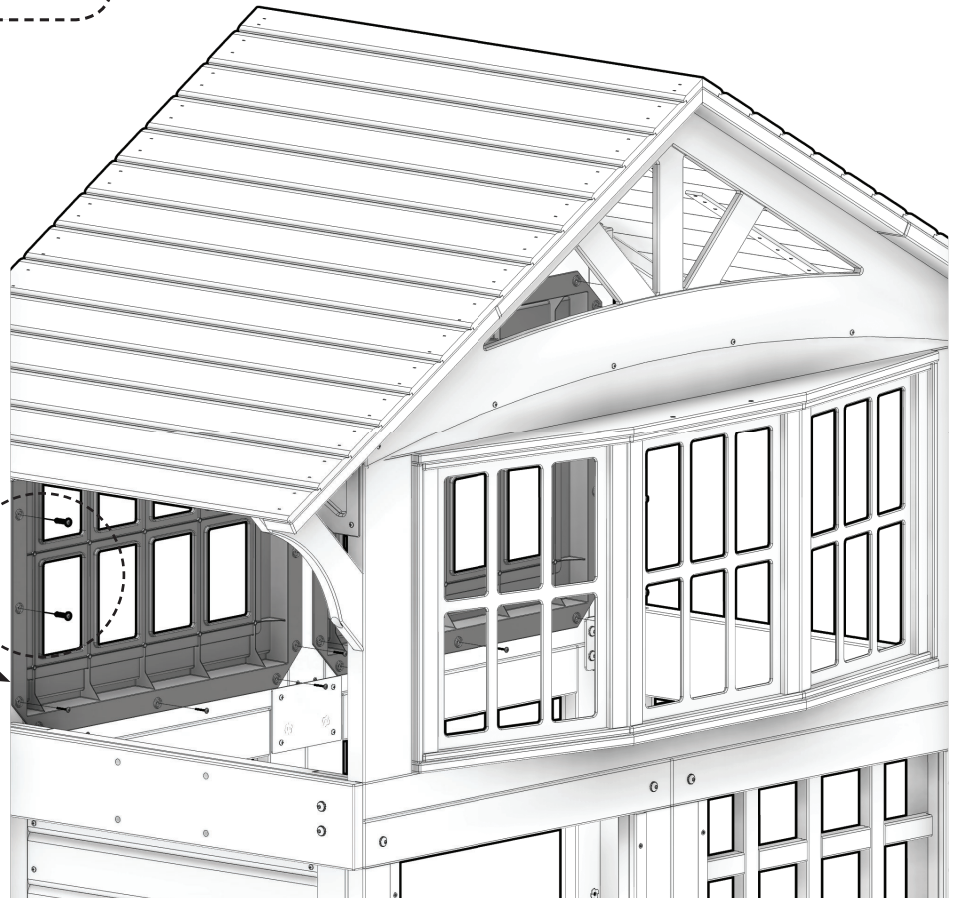

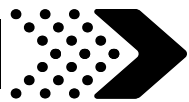

# Phase 5

# STEP 1

**F1** | POST - W4L12337  
(x1) 1-3/8" x 2-3/8" x 80" (36 x 60 x 2032)

**H2** | ARCHED RAIL - W4L12342  
(x1) 1" x 3-3/8" x 29-1/4" (24 x 86 x 744)

**F3** | POST - W4L12481  
(x1) 1-3/8" x 2-3/8" x 80" (36 x 60 x 2032)

**H8** | RAIL - W4L12458  
(x1) 1" x 3-3/8" x 29-1/4" (24 x 86 x 744)

**N1** | RAIL - W4L12334  
(x1) 5/8" x 2-3/8" x 28-3/8" (16 x 60 x 720)

**N4** | PICKET - W4L12341  
(x4) 5/8" x 2-3/8" x 17-5/8" (16 x 60 x 448)

**N5** | RAIL - W4L12470  
(x1) 5/8" x 2-3/8" x 28-3/8" (16 x 60 x 720)

**H100567** | BOLT WH BLK  
(x6) 1/4 x 2-1/4 - H100567

**H100488** | BOLT WH BLK  
(x8) 1/4 x 2 - H100488

**H100088** | SCREW PFH  
(x8) 8x1-1/8 - H100088

**H100398** | T-NUT BLK  
(x15) 1/4 - H100398

**H100405** | WASHER LOCK EXT BLK  
(x14) 6x15 - H100405

**ASSEMBLY NOTE:**  
IN THIS STEP YOU WILL BE CREATING  
"FRONT WALL SUB-ASSEMBLY" THAT  
WILL BE USED IN A LATER STEP.

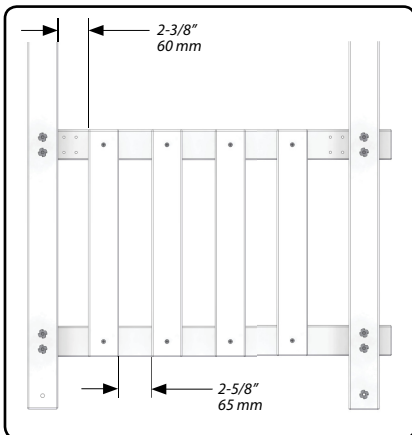
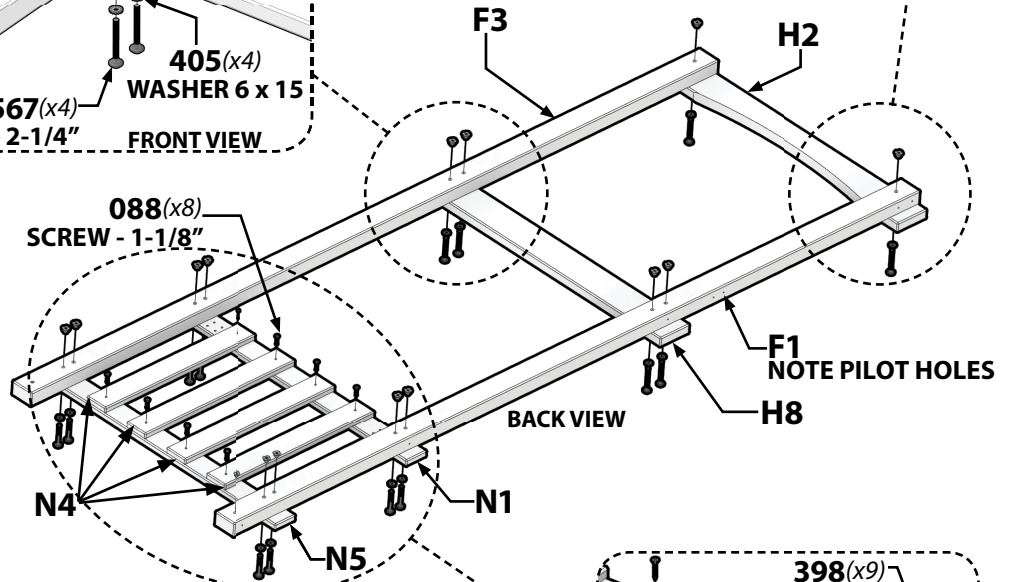
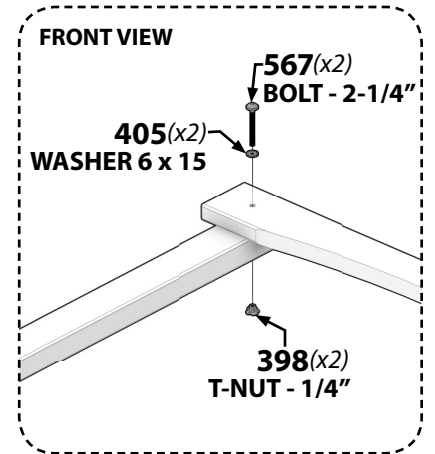
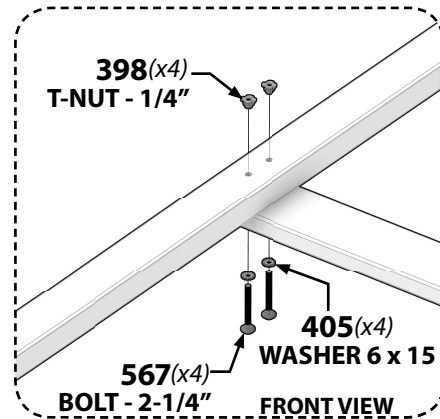
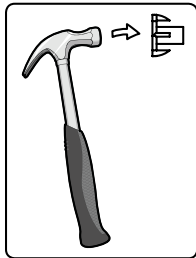

**PICKET PLACEMENT**

**ASSEMBLY NOTE:**  
BOARDS "F1" AND "F3" PILOT HOLES  
TO OUTSIDE.

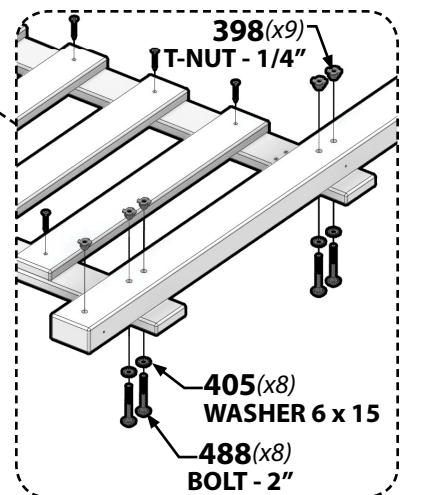



# Phase 5

## STEP 2

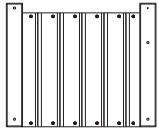

**WP8** (x1) | **WALL PANEL - W2A02775**  
1-7/16" x 18 - 1/16" x 21-13/16" (36 x 458 x 554)

**H7** (x1) | **RAIL - W4L12457**  
1" x 3-3/8" x 18" (24 x 86 x 458)

**H15** (x1) | **RAIL - W4L12339**  
1" x 3-3/8" x 18" (24 x 86 x 458)



**A4M00555** (x2) | **L BRACKET BLK**  
A4M00555



**A4M00710** (x2) | **L BRACKET BLACK 32X51**  
A4M00710

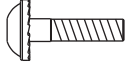

**H100171** (x1) | **BOLT WH BLK**  
1/4x1 - H100171



**H100398** (x1) | **T-NUT BLK**  
1/4 - H100398

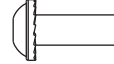

**H100399** (x3) | **NUT BARREL WH BLK**  
1/4 x 7/8 - H100399



**H100400** (x3) | **WASHER LOCK EXT BLK**  
8x15 - H100400



**H100401** (x2) | **BOLT WH BLK**  
1/4 x 1/2 - H100401

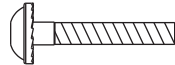

**H100406** (x2) | **BOLT WH BLK**  
1/4x1-1/2 - H100406



**H100536** (x2) | **SCREW PWH BLK**  
8 x 1-1/4 - H100536

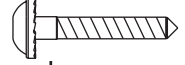

**H100403** (x1) | **LAG SCREW WH BLK**  
1/4 x 1-1/2 - H100403

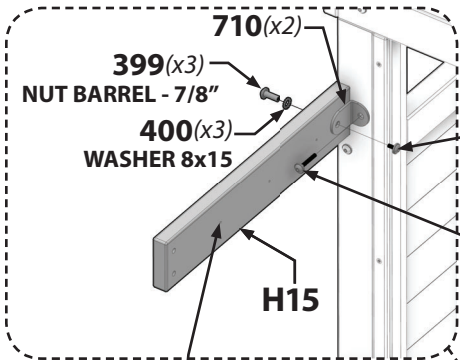

**ASSEMBLY NOTE:**  
ASSEMBLE T-NUT FIRST INTO 'WP8'.

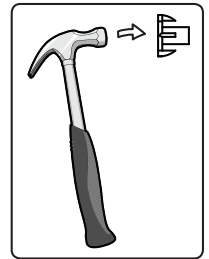

**ASSEMBLY NOTE:**  
REPEAT PROCESS ABOVE ON H7 BORD. NOTE PILOT HOLES.

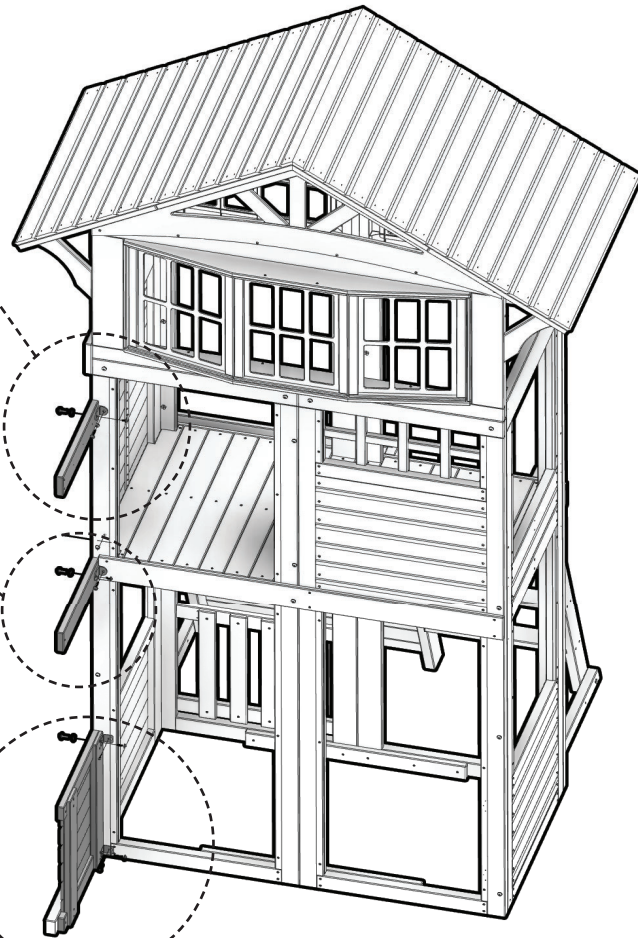
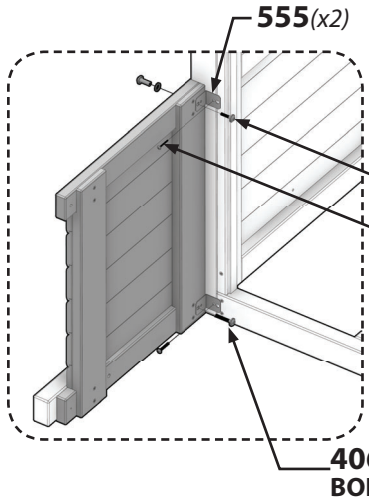
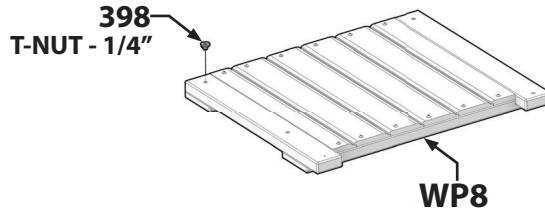
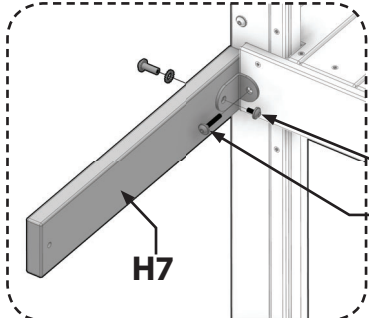



# Phase 5

## STEP 3

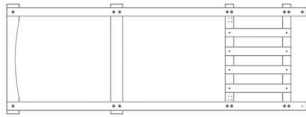

FRONT WALL SUB-ASSEMBLY



**J7** | BOTTOM BOARD - W4L12471  
(x1) | 1" x 2-3/8" x 28-3/8" (24 x 60 x 720)



**T4** | TRIM - W4L11771  
(x1) | 1" x 1-3/8" x 17" (24 x 34 x 432)

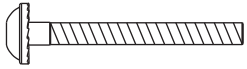

**H100567** | BOLT WH BLK  
(x1) | 1/4 x 2-1/4 - H100567

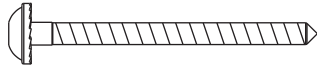

**H100792** | LAG SCREW WH BLK  
(x1) | 1/4 x 3 - H100792

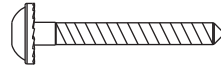

**H100487** | LAG SCREW WH BLK  
(x4) | 1/4 x 2 - H100487



**H100111** | SCREW PFH  
(x3) | 8x2 - H100111



**H100405** | WASHER LOCK EXT BLK  
(x6) | 6x15 - H100405

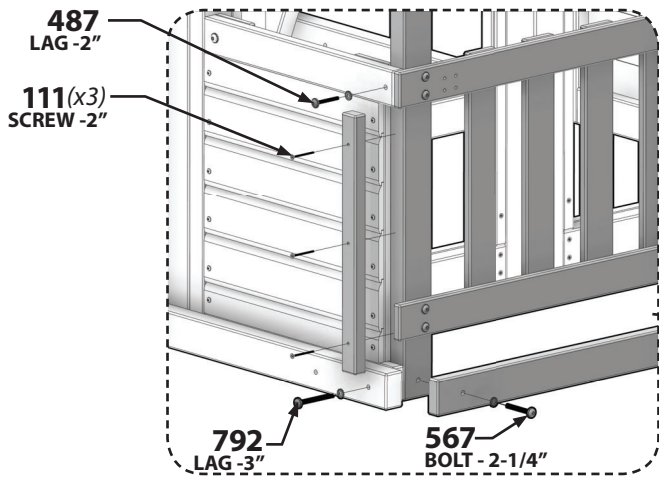
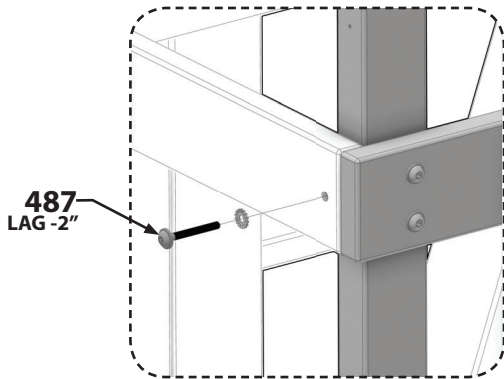
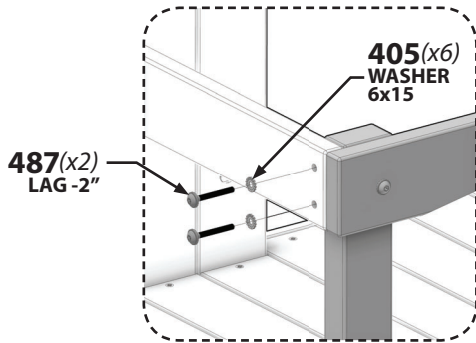

**ASSEMBLY NOTE:**  
NOTE BOARD ORIENTATION.

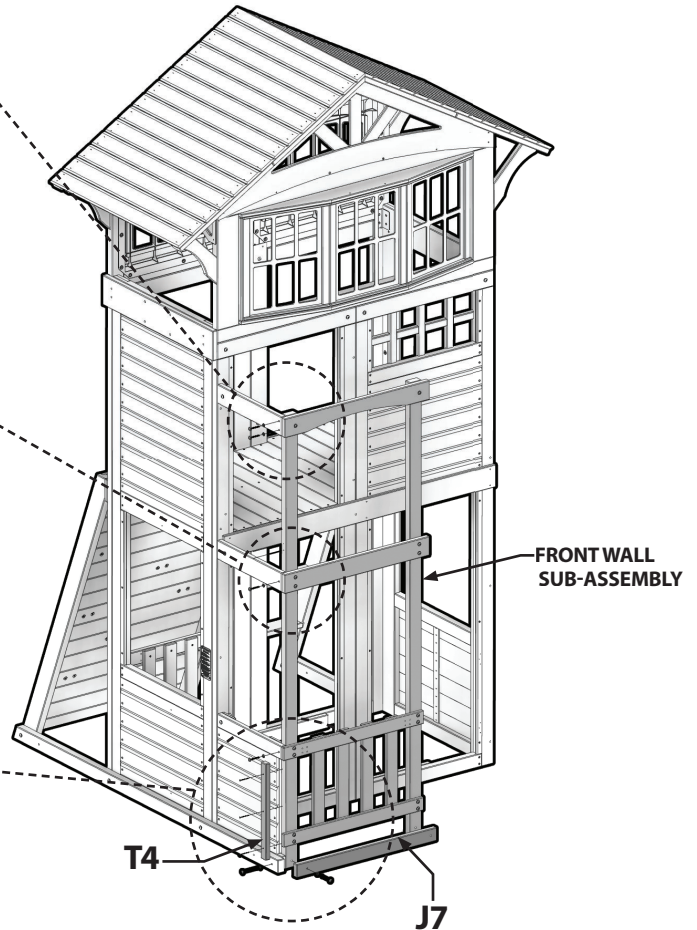



# Phase 5

## STEP 4

**H6** | RAIL - W4L12456  
(x1) | 1" x 3-3/8" x 17-3/8" (24 x 86 x 442)

**H15** | RAIL - W4L12339  
(x1) | 1" x 3-3/8" x 18" (24 x 86 x 458)

**A4M00710** | L BRACKET BLACK 32X51  
(x2) | A4M00710



**H100399** | NUT BARREL WH BLK  
(x2) | 1/4 x 7/8 - H100399

**H100400** | WASHER LOCK EXT BLK  
(x2) | 8x15 - H100400

**H100401** | BOLT WH BLK  
(x2) | 1/4 x 1/2 - H100401

**H100406** | BOLT WH BLK  
(x1) | 1/4 x 1-1/2 - H100406

**H100405** | WASHER LOCK EXT BLK  
(x3) | 6x15 - H100405

**H100487** | LAG SCREW WH BLK  
(x3) | 1/4 x 2 - H100487

**H100403** | LAG SCREW WH BLK  
(x1) | 1/4 x 1-1/2 - H100403

**ASSEMBLY NOTE:**  
NOTE PILOT HOLE ORIENTATION.

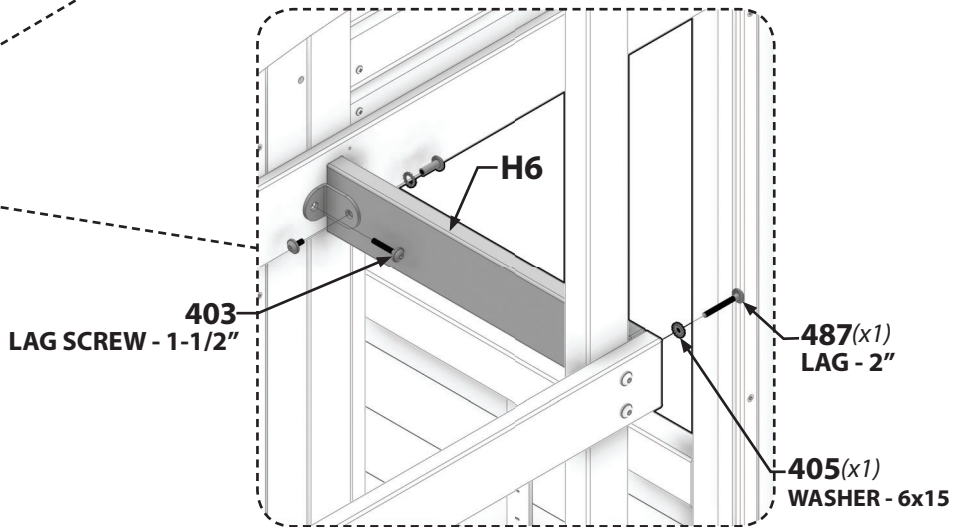
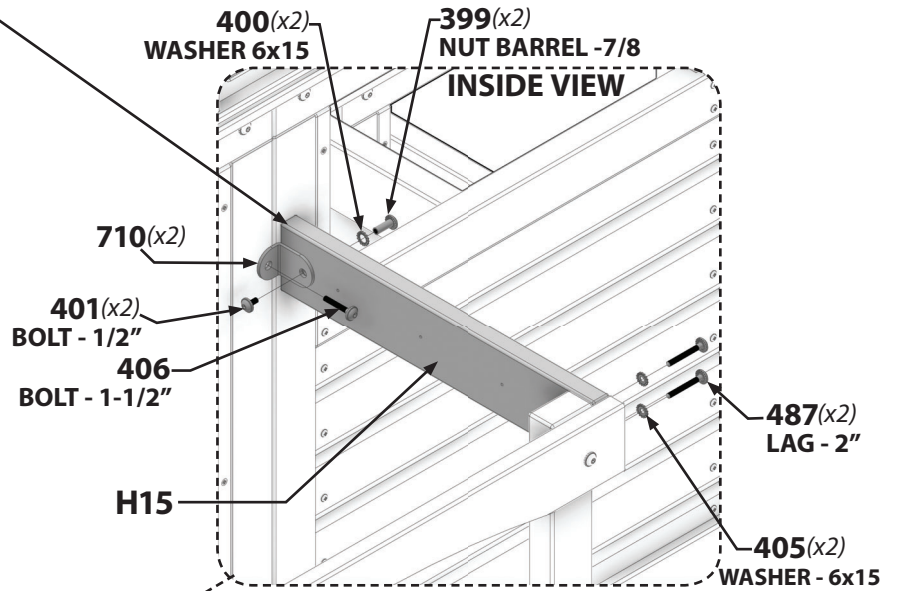
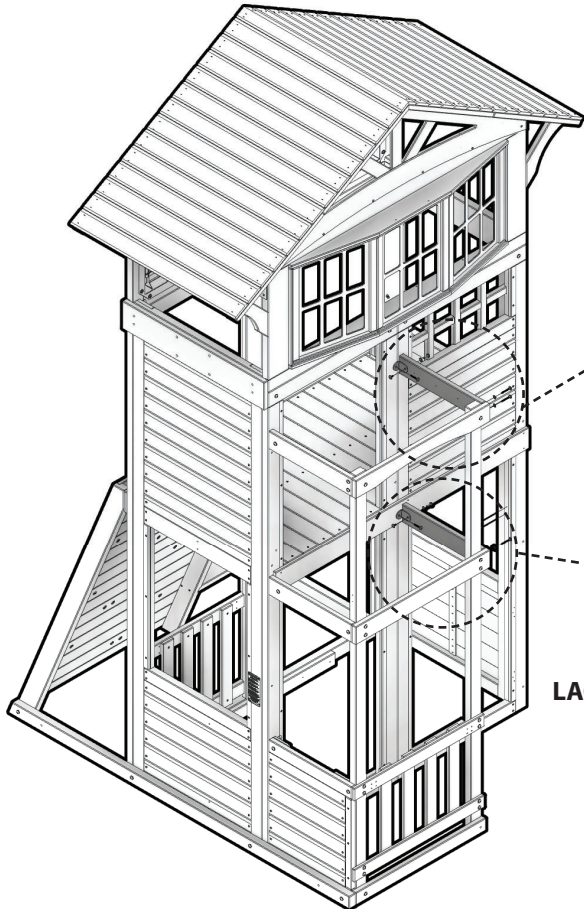

**ASSEMBLY NOTE:**  
REPEAT ON H6 BOARD ATTACHMENT.



# Phase 5

# STEP 5



**H13** | FLOOR JOIST - W4L12482  
(x1) | 1" x 3-3/8" x 23" (24 x 86 x 585)



**H100111** | SCREW PFH  
(x3) | 8x2 - H100111



**FLUSH WITH BOTTOM OF RAIL.  
DISTANCE BETWEEN BOARDS "H7" AND "H6"  
FROM BOARD "H13" IS 45MM FROM EACH END.**

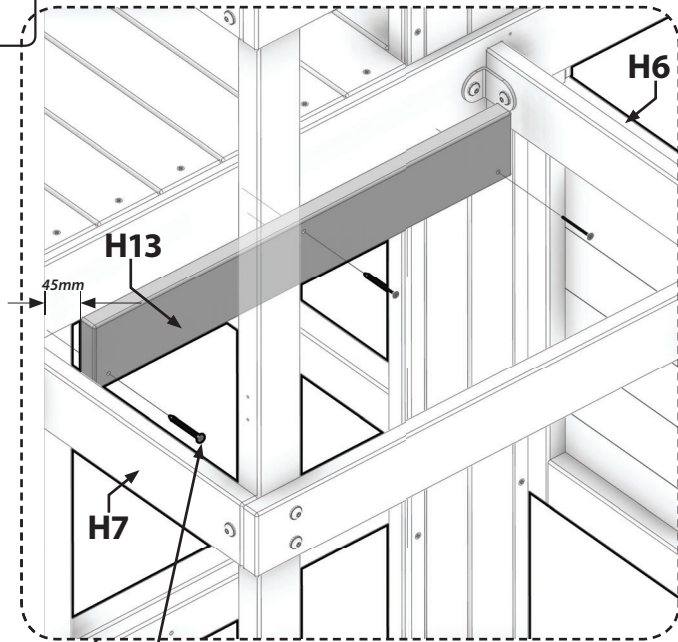

**111(x3)  
SCREW - 2"**

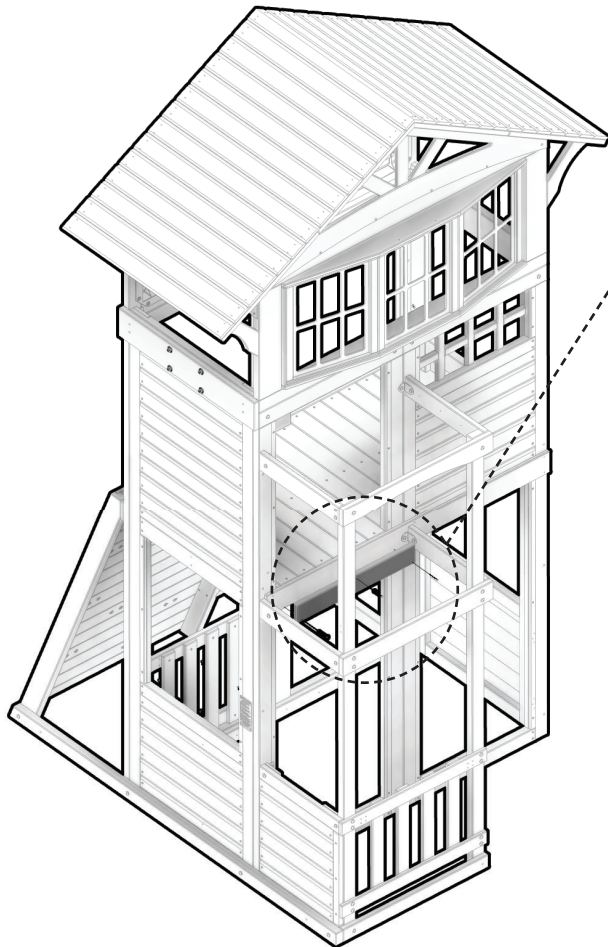



# Phase 5

# STEP 6

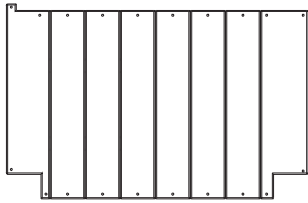

**FP1** | FLOOR PANEL - W2A02777  
(x1) | 1-1/4" x 19" x 29-1/4" (32 x 482 x 744)



**H100086** | SCREW PFH  
(x20) | 8x1-1/2 - H100086

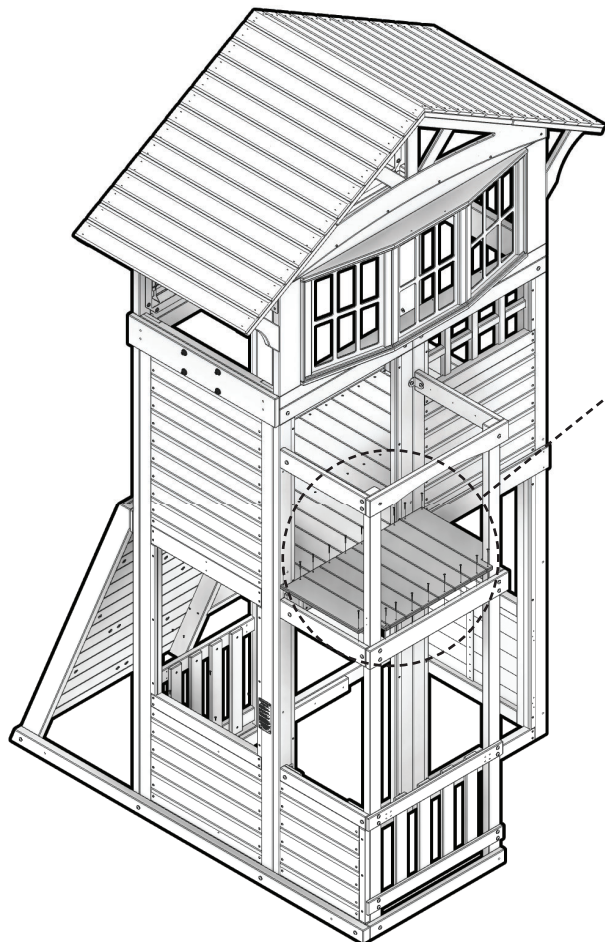
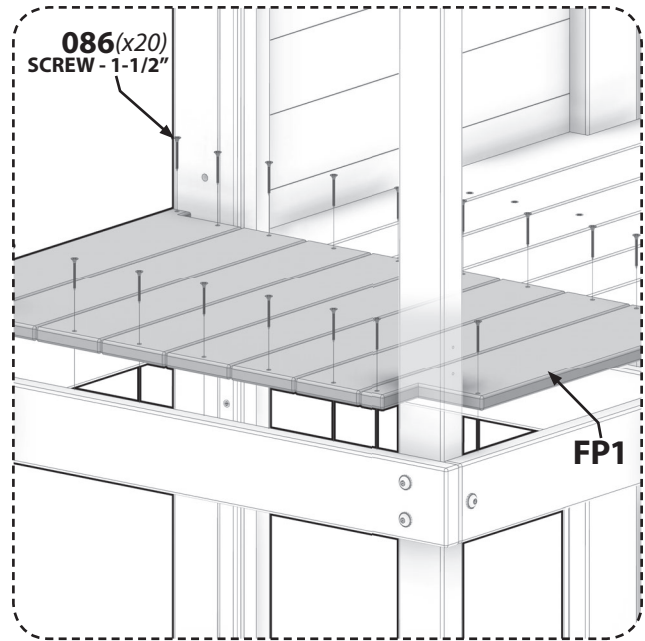



# Phase 5

## STEP 7

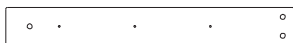

**J2** | **RAIL - W4L12338**  
(x2) | 1" x 2-3/8" x 18" (24 x 60 x 458)



**A4M00710** | **L BRACKET BLACK 32X51**  
(x2) | A4M00710

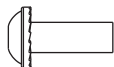

**H100399** | **NUT BARREL WH BLK**  
(x2) | 1/4 x 7/8 - H100399



**H100400** | **WASHER LOCK EXT BLK**  
(x2) | 8x15 - H100400



**H100401** | **BOLT WH BLK**  
(x2) | 1/4 x 1/2 - H100401



**H100405** | **WASHER LOCK EXT BLK**  
(x4) | 6x15 - H100405

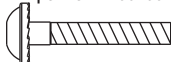

**H100406** | **BOLT WH BLK**  
(x2) | 1/4 x 1-1/2 - H100406

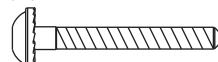

**H100487** | **LAG SCREW WH BLK**  
(x4) | 1/4 x 2 - H100487

**NOTE: THE 'J2' RAIL IS ASSEMBLED THE SAME ON BOTH SIDES OF THE BALCONY SHOWN BELOW.**

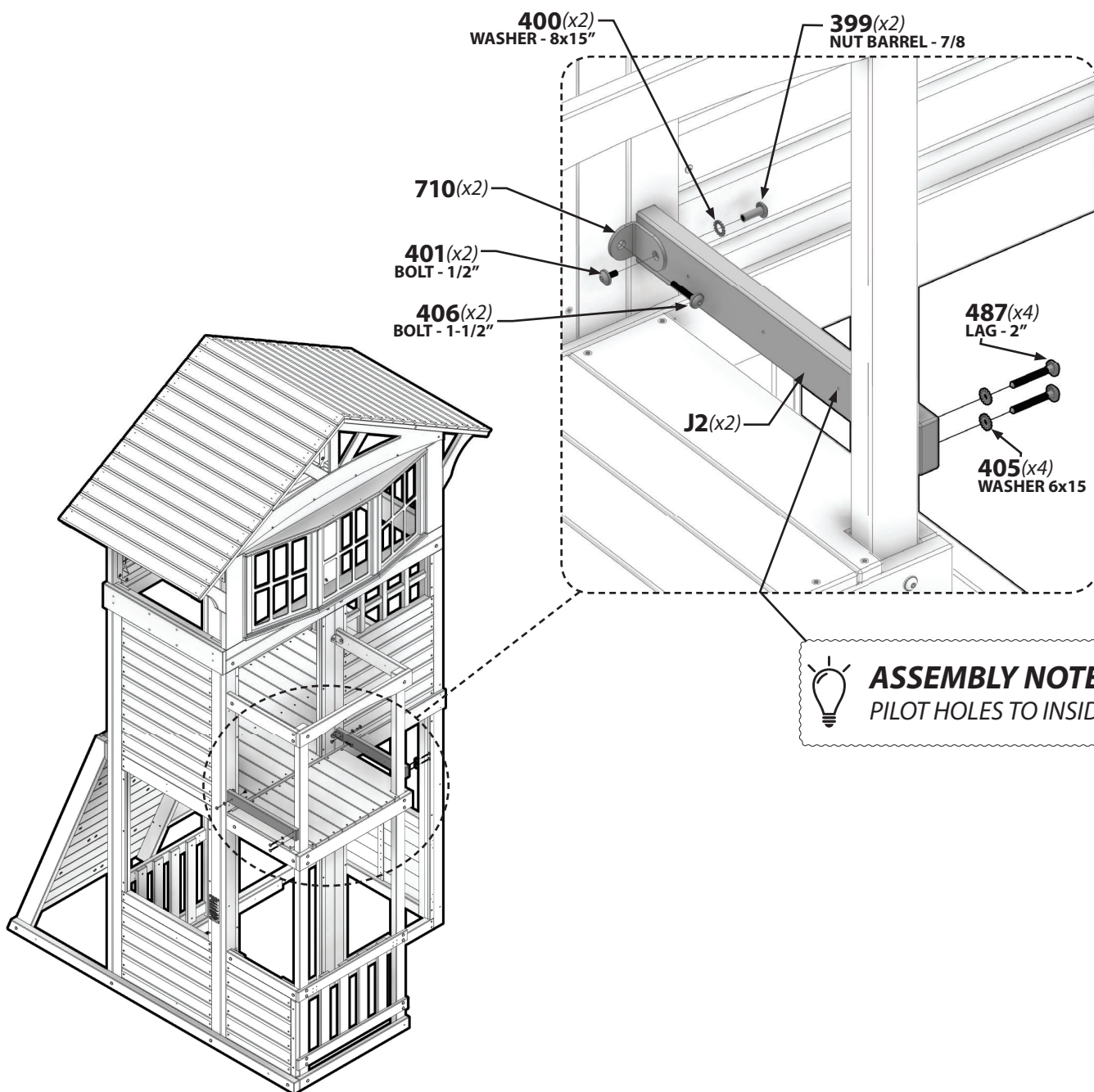

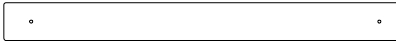
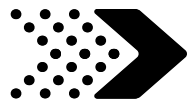

**N3** | RAIL - W4L12340  
(x6) | 5/8" x 2-3/8" x 24-5/8" (16 x 60 x 626)



**H100088** | SCREW PFH  
(x12) | 8x1-1/8" - H100088



**ASSEMBLY NOTE:**  
USE PILOT HOLES FOR SPACING.

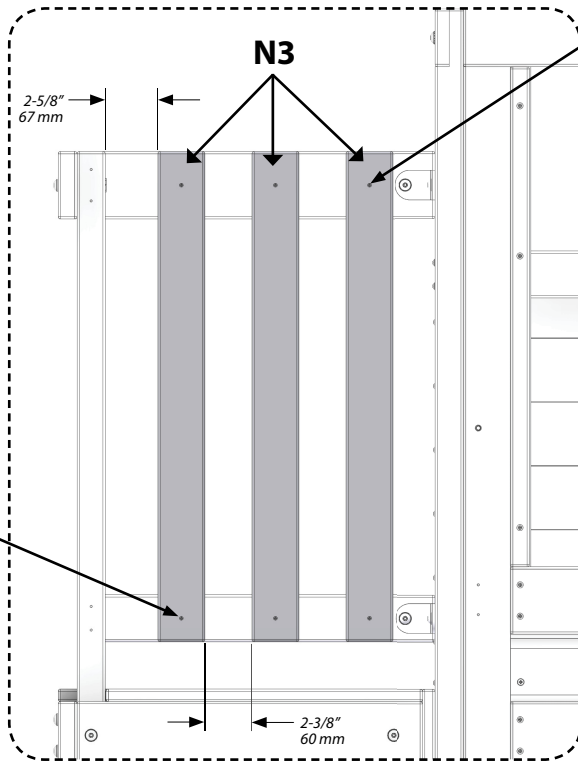

**PICKET PLACEMENT  
FOR BOTH SIDES**

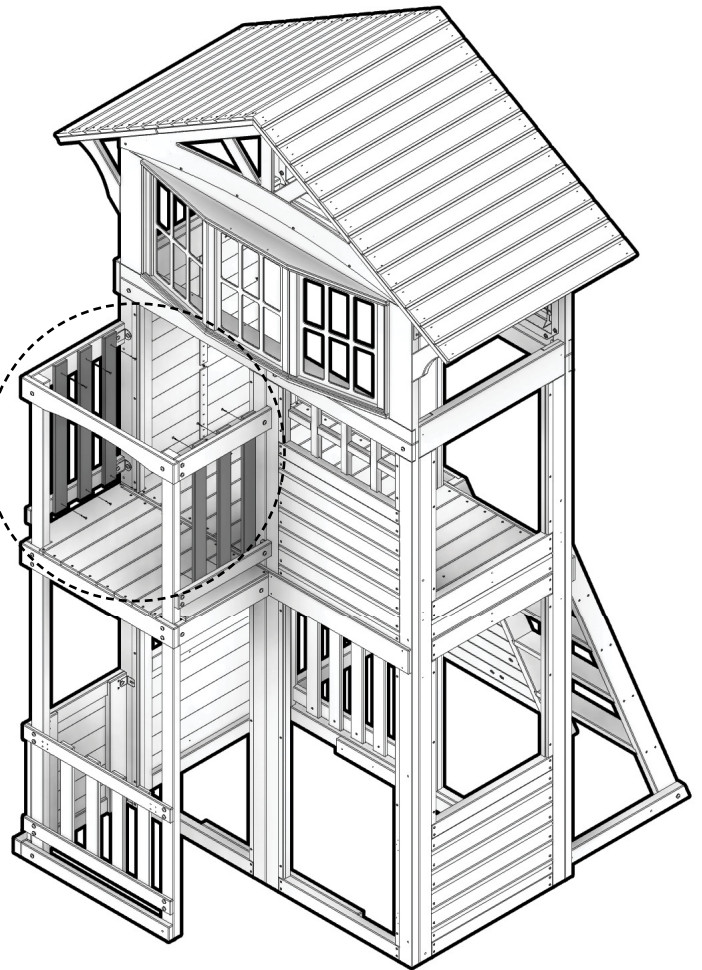



# Phase 6

# STEP 1

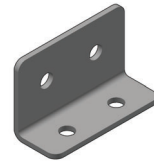
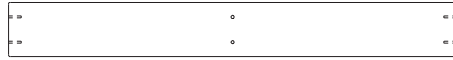
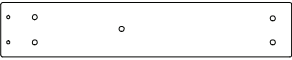

**E1**  
(x2) **RAIL - W4L12344**  
1-3/8" x 3-3/8" x 18" (36 x 86 x 462)

**H9**  
(x1) **RAIL - W4L12451**  
1" x 3-3/8" x 28" (24 x 86 x 712)

**A4M00855**  
(x2) **L BRACKET 51X32X82X3.125**  
A4M00855

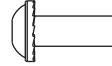
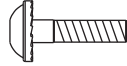
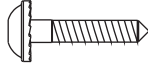

**H100201**  
(x4) **SCREW PFH BLK**  
8x2-1/2 - H100201

**H100568**  
(x4) **LAG SCREW WH BLK**  
1/4x1-1/4 - H100568

**H100171**  
(x4) **BOLT WH BLK**  
1/4x1 - H100171

**H100399**  
(x4) **NUT BARREL WH BLK**  
1/4x7/8 - H100399

**H100400**  
(x4) **WASHER LOCK EXT BLK**  
8x15 - H100400

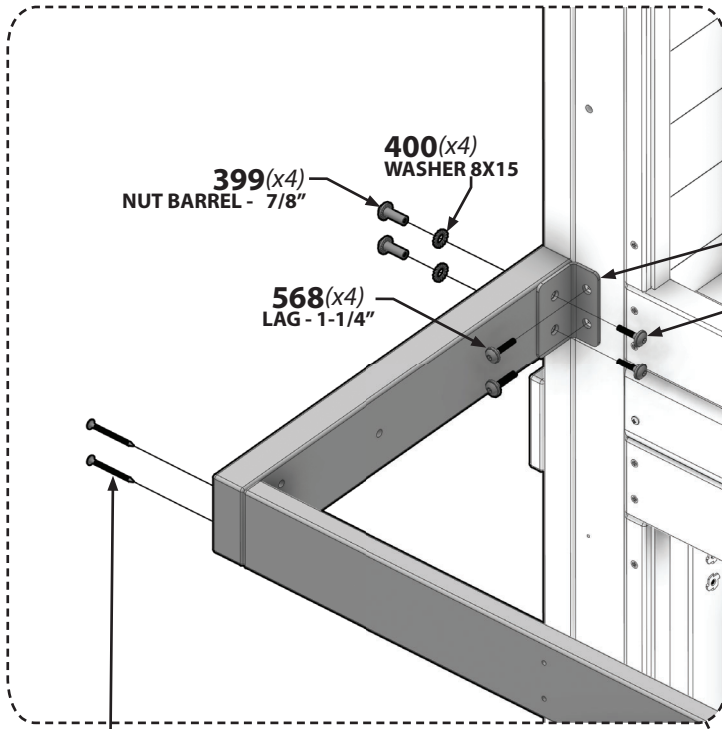

 **ASSEMBLY NOTE:**  
USE PILOT HOLES AS GUIDE.

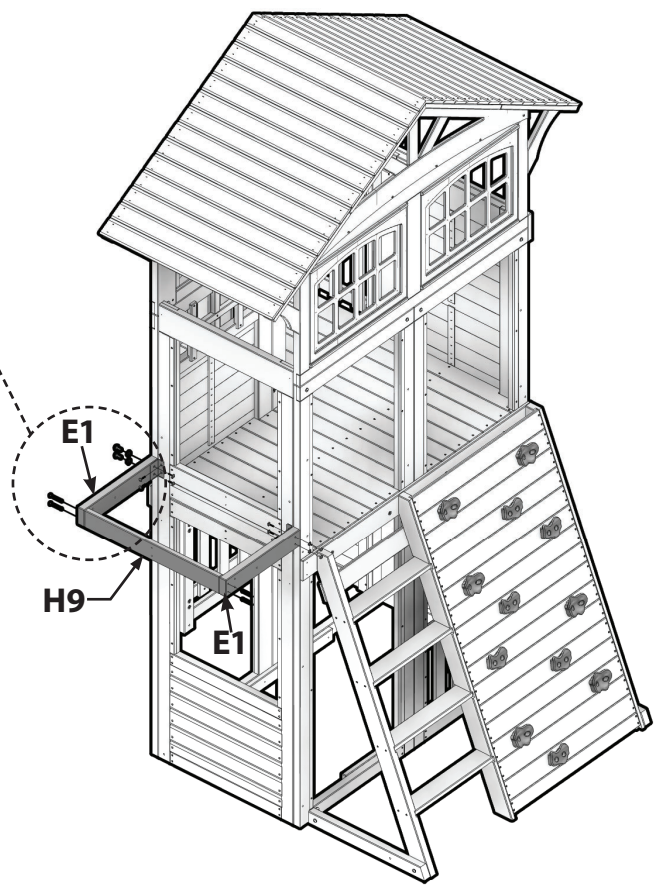



**F2** | **ANGLE BRACE - W4L12343**  
 (x2) | 1-3/8" x 3-3/8" x 20-1/8" (36 x 86 x 510)

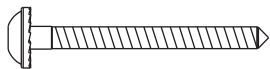

**H100456** | **LAG SCREW WH BLK**  
 (x2) | 1/4x2-1/2 - H100456

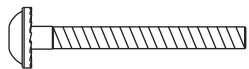

**H100567** | **BOLT WH BLK**  
 (x2) | 1/4x2-1/4 - H100567

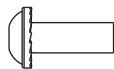

**H100399** | **NUT BARREL WH BLK**  
 (x2) | 1/4 x 7/8 - H100399



**H100405** | **WASHER LOCK EXT BLK**  
 (x4) | 6x15 - H100405



**H100400** | **WASHER LOCK EXT BLK**  
 (x2) | 8x15 - H100400

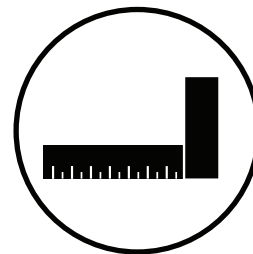
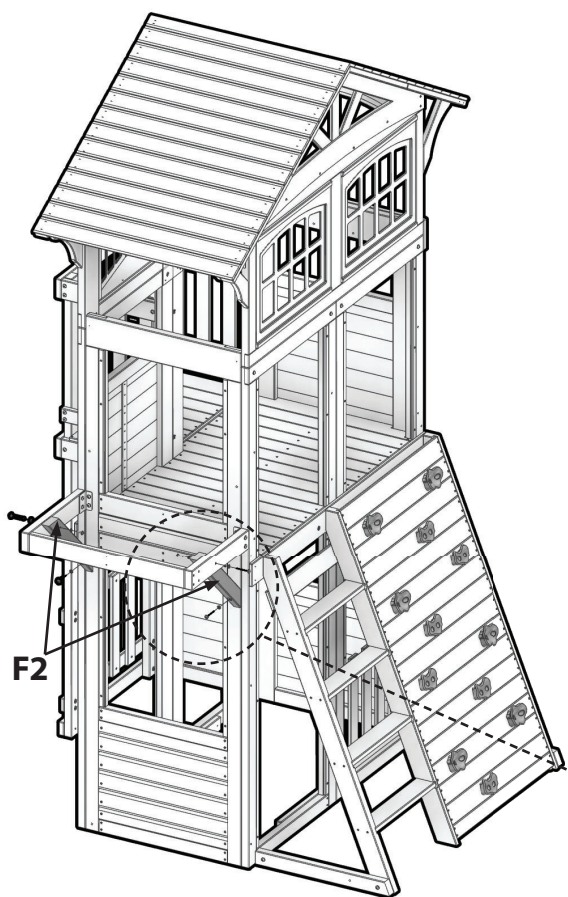

**ASSEMBLY NOTE:**  
 REPEAT PROCESS FOR BOTH  
 ANGLE BRACES.

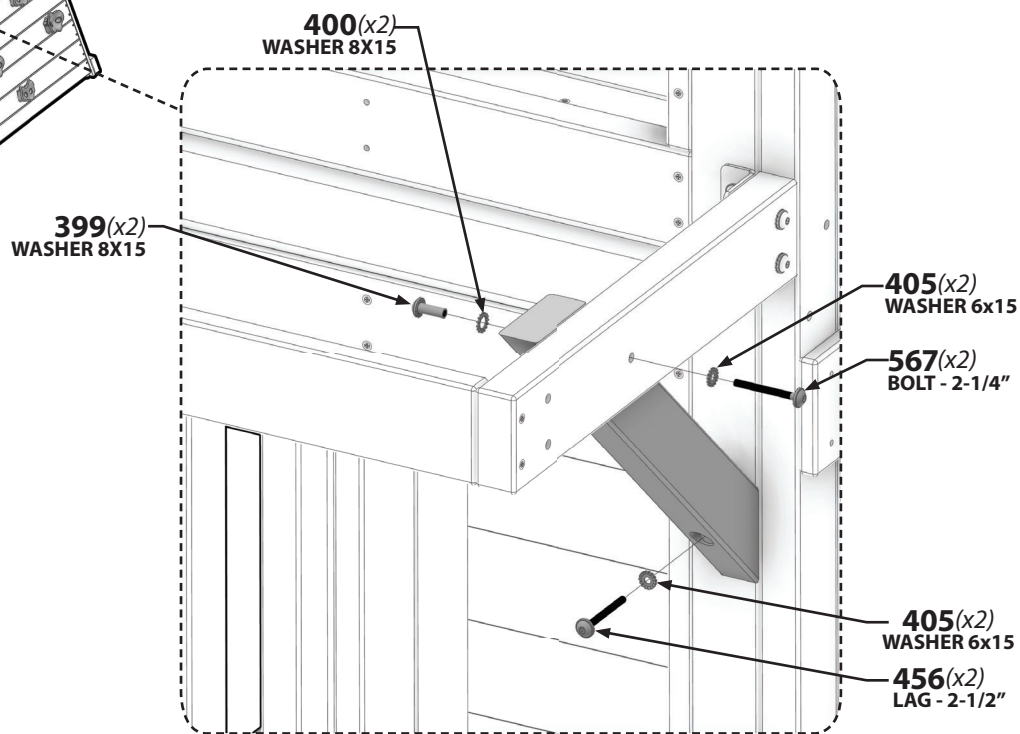



# Phase 6

# STEP 3

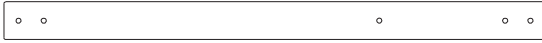

**J4** | **POST - W4L12454**  
(x2) | 1" x 2-3/8" x 33-7/8" (24 x 60 x 859)

**J12** | **FLOOR SUPPORT - W4L1772**  
(x2) | 1" x 2-3/8" x 3-7/8" (24 x 60 x 86)

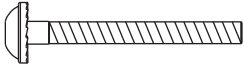

**H100567** | **BOLT WH BLK**  
(x4) | 1/4x2-1/4 - H100567



**H100111** | **SCREW PFH**  
(x4) | 8x2 - H100111



**H100398** | **T-NUT BLK**  
(x4) | 1/4 - H100398



**H100405** | **WASHER LOCK EXT BLK**  
(x4) | 6x15 - H100405

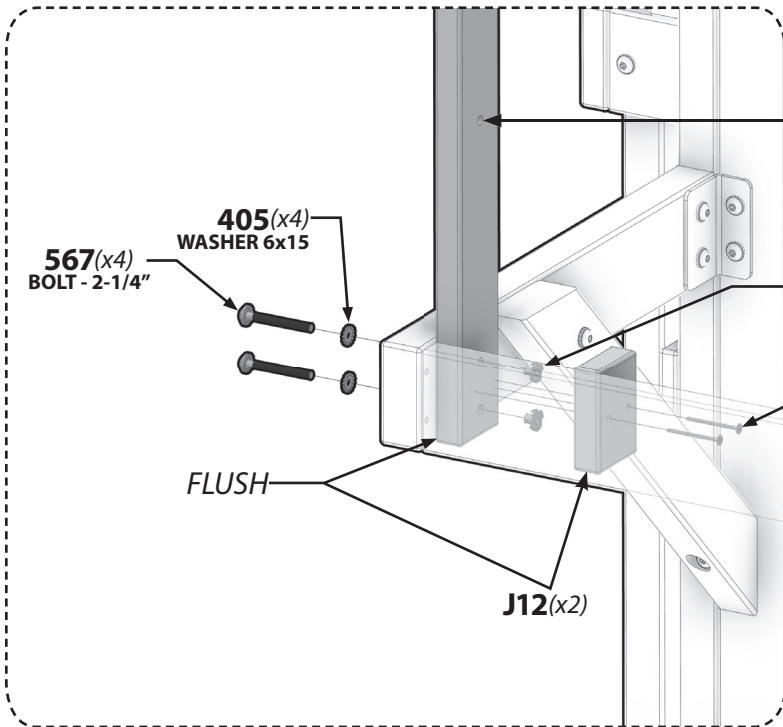

### ASSEMBLY NOTE:

NOTE HOLE AT BOTTOM  
REPEAT THIS STEP ON OPPOSITE SIDE.

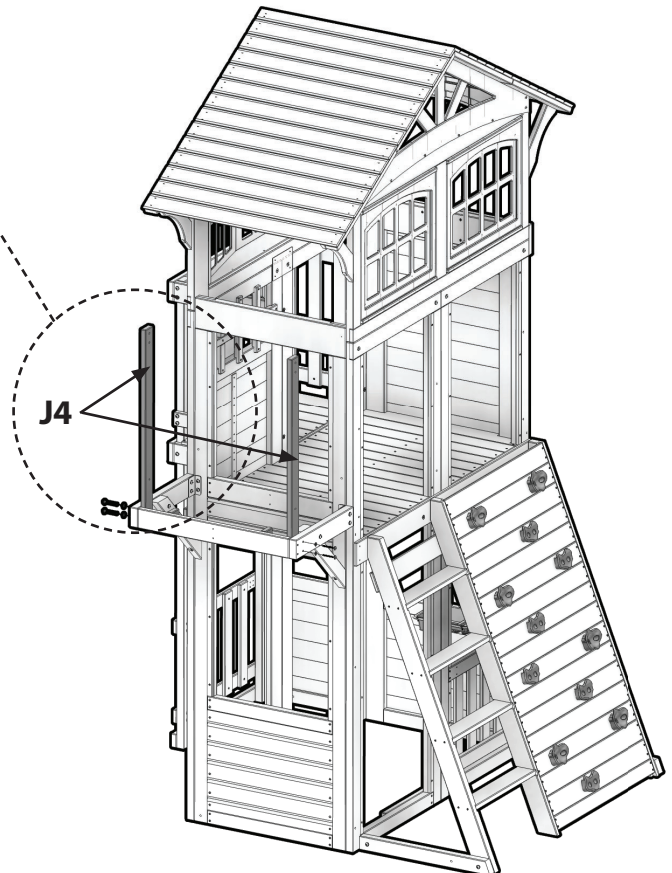



# Phase 6

## STEP 4



**H5** | FLOOR JOIST - W4L12455  
(x1) | 1" x 3-3/8" x 17-1/4" (24 x 86 x 438)



**H100201** | SCREW PFH BLK  
(x2) | 8x2-1/2 - H100201



**H100092** | SCREW PFH  
(x2) | 8x3 - H100092

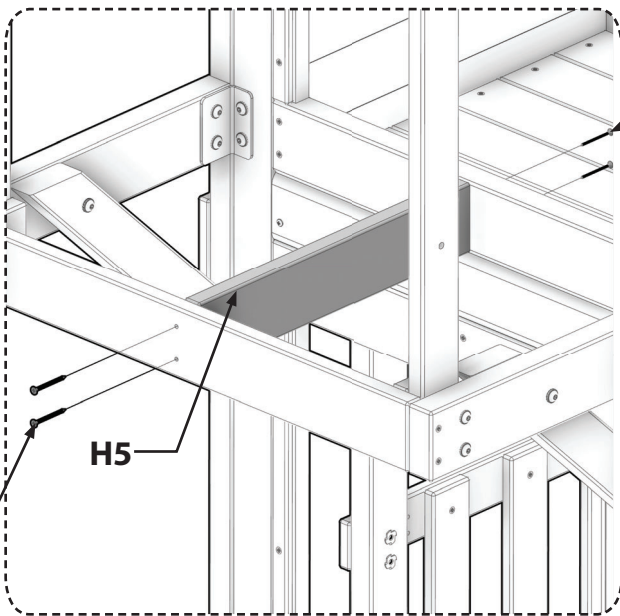

**092(x2)**  
SCREW - 3"

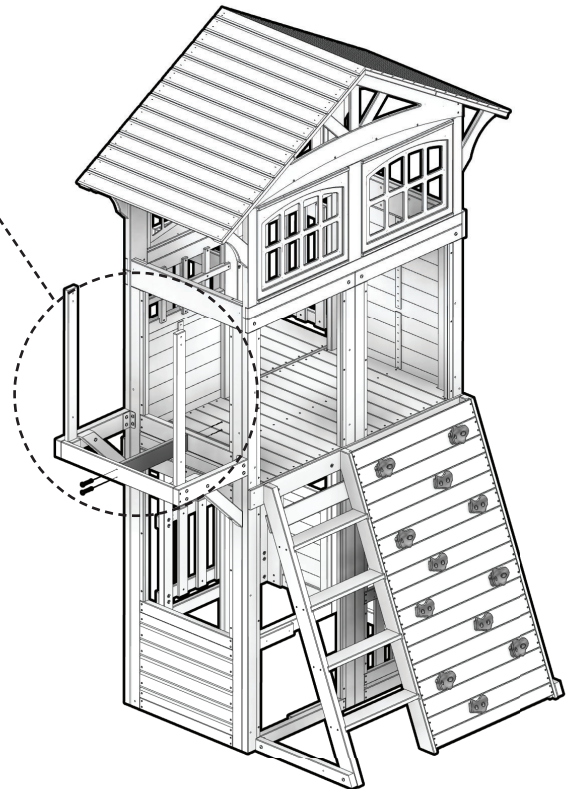

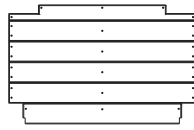

**FP2** | **FLOOR PANEL - W2A02778**  
(x1) | 1-1/4" x 19-9/16" x 30-7/8" (32 x 498 x 784)



**H100086** | **SCREW PFH**  
(x28) | 8x1-1/2 - H100086

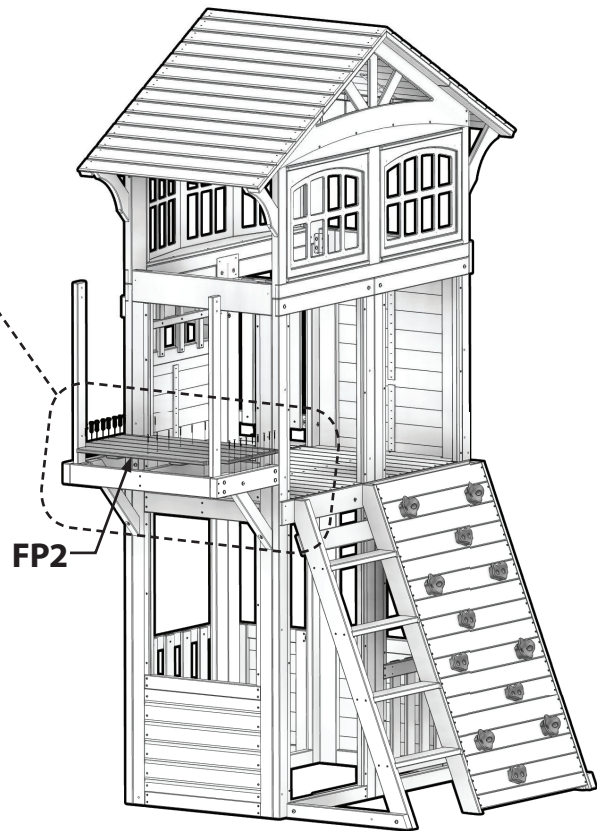
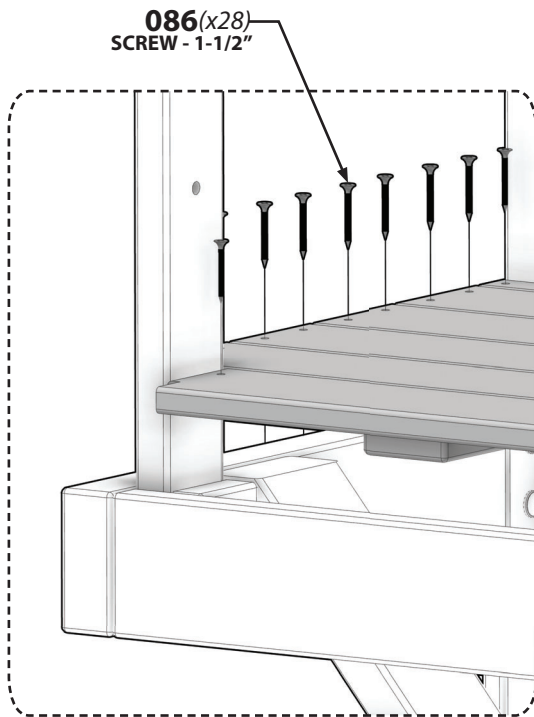



# Phase 6

# STEP 6

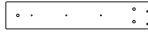
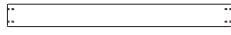
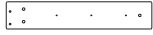

**H4** | RAIL - W4L12452  
(x1) | 1" x 3-3/8" x 18-1/4" (24 x 86 x 462)

**H11** | RAIL - W4L12462  
(x1) | 1" x 2-3/4" x 28" (24 x 71 x 712)

**H12** | RAIL - W4L12463  
(x1) | 1" x 3-3/8" x 18-1/4" (24 x 86 x 462)

**A4M00710** | L BRACKET BLACK 32X51  
(x2) | A4M00710

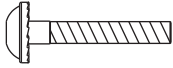

**H100406** | BOLT WH BLK  
(x4) | 1/4x1-1/2 - H100406



**H100401** | BOLT WH BLK  
(x2) | 1/4 x 1/2 - H100401

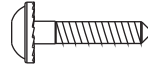

**H100568** | LAG SCREW WH BLK  
(x2) | 1/4x1-1/4 - H100568

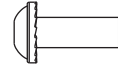

**H100399** | NUT BARREL WH BLK  
(x6) | 1/4 x 7/8 - H100399



**H100391** | SCREW PFH BLK  
(x4) | 8x2 - H100391



**H100405** | WASHER LOCK EXT BLK  
(x4) | 6x15 - H100405



**H100400** | WASHER LOCK EXT BLK  
(x6) | 8x15 - H100400



**ASSEMBLY NOTE:**  
PILOT HOLES TO INSIDE.

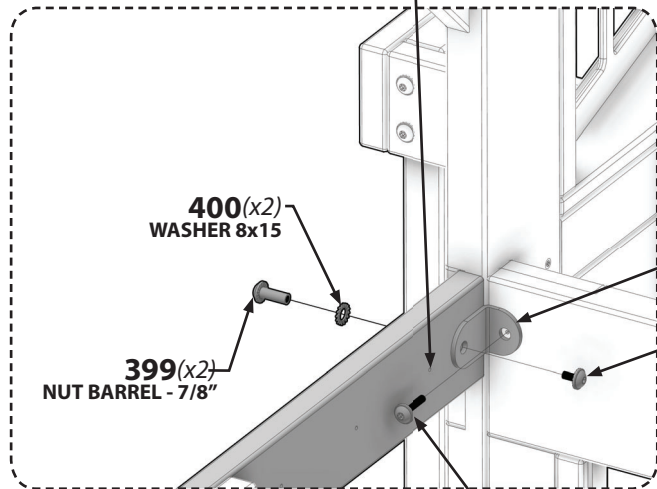

**400(x2)**  
WASHER 8x15

**399(x2)**  
NUT BARREL - 7/8"

**710(x2)**

**401(x2)**  
BOLT - 1/2"

**568(x2)**  
LAG - 1-1/4"

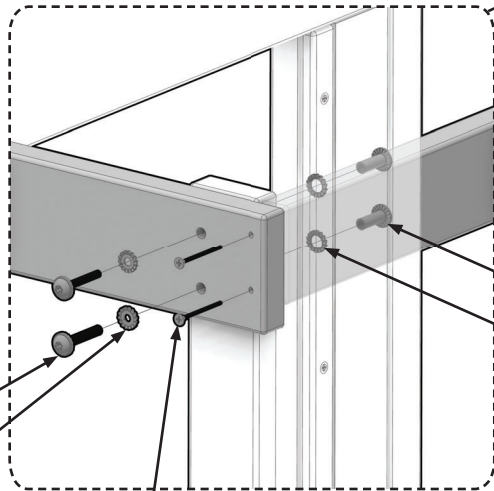

**406(x4)**  
BOLT - 1-1/2"

**405(x4)**  
WASHER 6x15

**391(x4)**  
SCREW - 2"

**399(x4)**  
NUT BARREL - 7/8"  
**400(x4)**  
WASHER 8x15

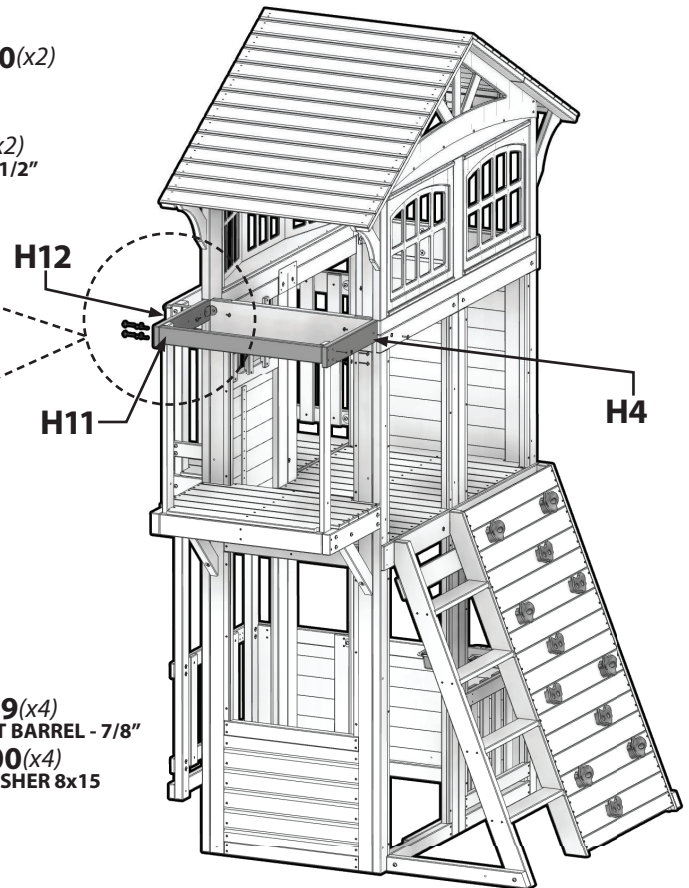

**H12**

**H11**

**H4**



# Phase 6

# STEP 7

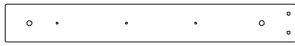

**J3** | **RAIL - W4L12453**  
(x2) | 1" x 2-3/8" x 18-1/4" (24 x 60 x 462)



**A4M00710** | **L BRACKET BLACK 32X51**  
(x2) | A4M00710

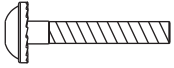

**H100406** | **BOLT WH BLK**  
(x4) | 1/4x1-1/2 - H100406



**H100401** | **BOLT WH BLK**  
(x2) | 1/4x1/2 - H100401

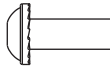

**H100399** | **NUT BARREL WH BLK**  
(x4) | 1/4 x 7/8 - H100399



**H100405** | **WASHER LOCK EXT BLK**  
(x2) | 6x15 - H100405



**H100400** | **WASHER LOCK EXT BLK**  
(x4) | 8x15 - H100400

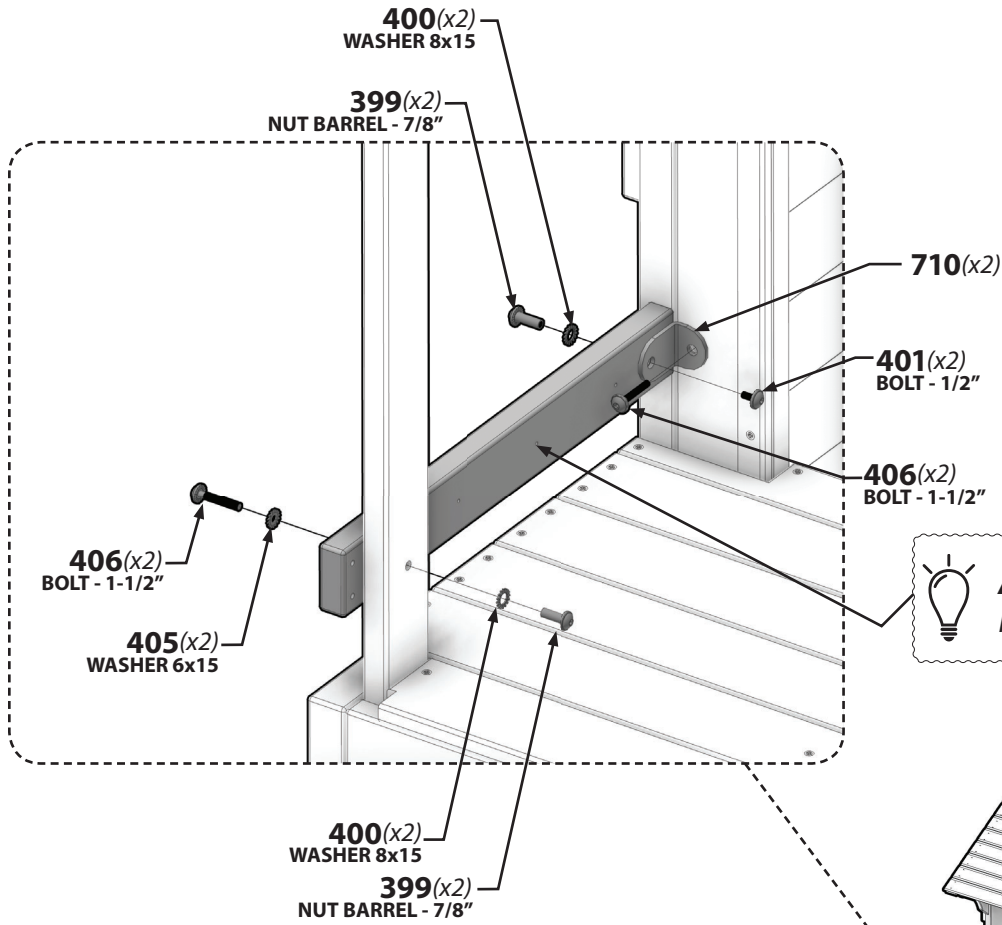

 **ASSEMBLY NOTE:**  
REPEAT PROCESS FOR BOTH  
"J3" BOARDS.

 **ASSEMBLY NOTE:**  
PILOT HOLES TO INSIDE.

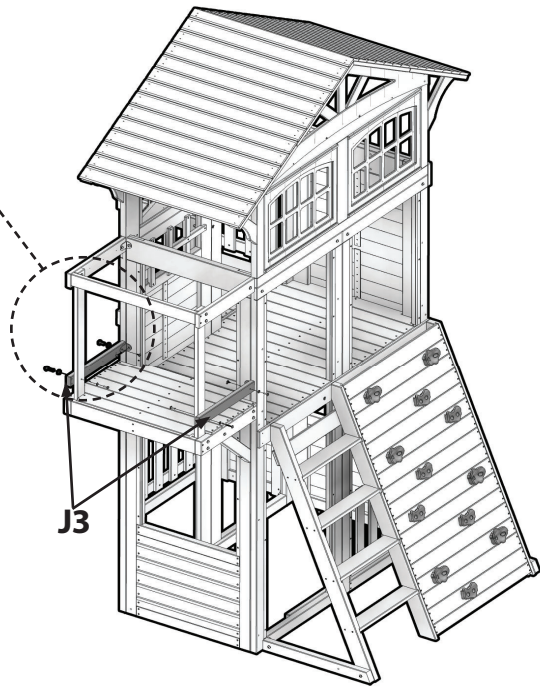



# Phase 6

# STEP 8

**T2** | TRIM - W4L12483  
(x1) | 1" x 1-3/8" x 27-5/8" (24 x 34 x 702)

**T3** | TRIM - W4L12484  
(x1) | 1" x 1-3/8" x 27-5/8" (24 x 34 x 702)

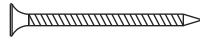

**H100391** | SCREW PFH BLK  
(x4) | 8x2 - H100391



**H100089** | SCREW PFH  
(x6) | 8x1-3/4 - H100089

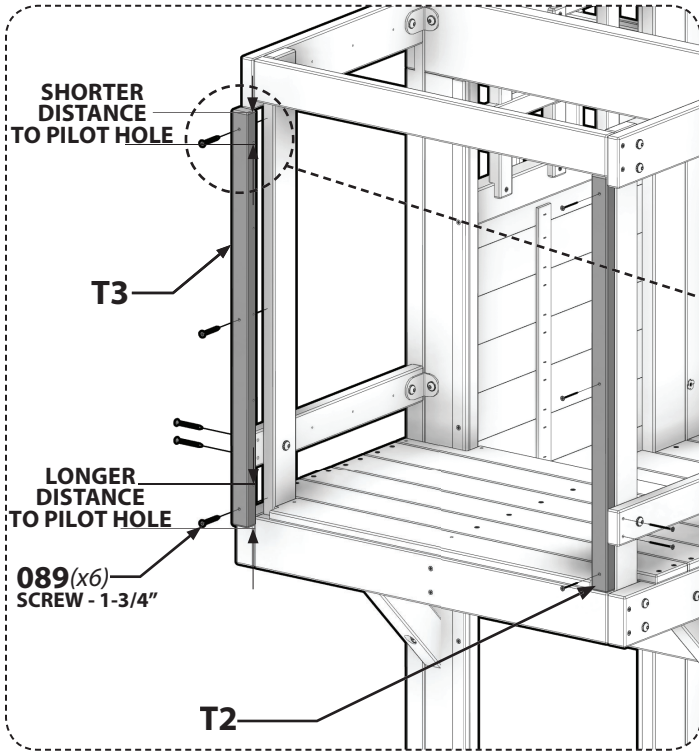

**ASSEMBLY NOTE:**  
NOTE PILOT HOLES OF BOARDS.

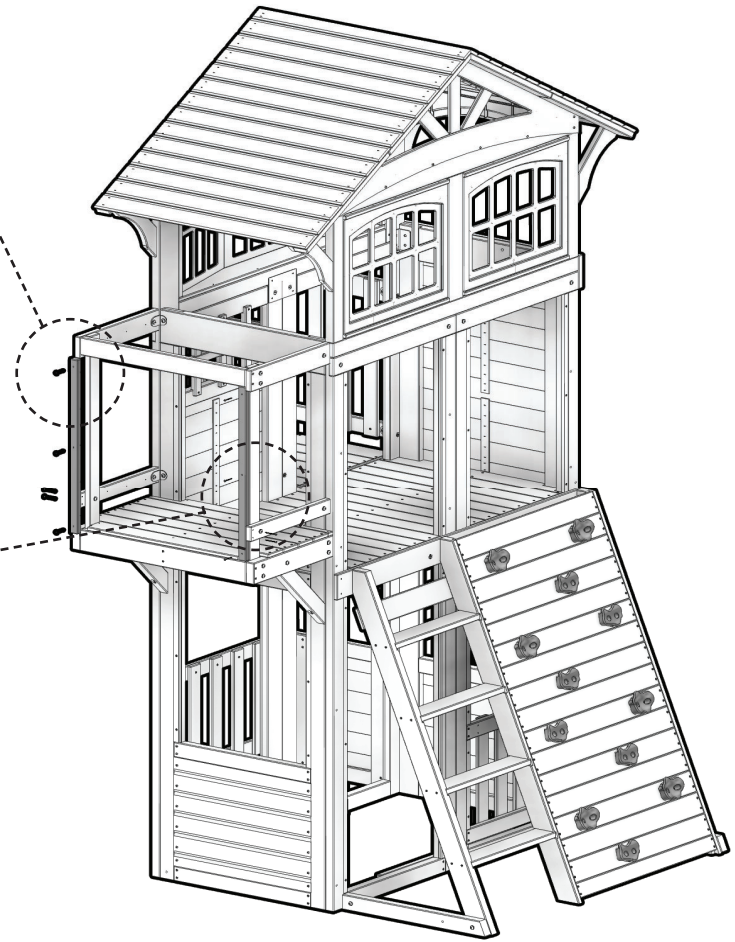
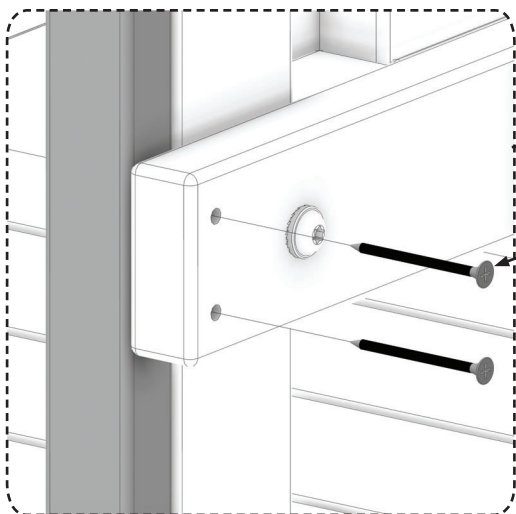



**N6** | RAIL - W4L12582  
(x6) | 5/8"x2 3/8"x27 1/8" (16x60x690)



**H100088** | SCREW PFH  
(x12) | 8x1-1/8 - H100088



**ASSEMBLY NOTE:**  
USE PILOT HOLES FOR SPACING.

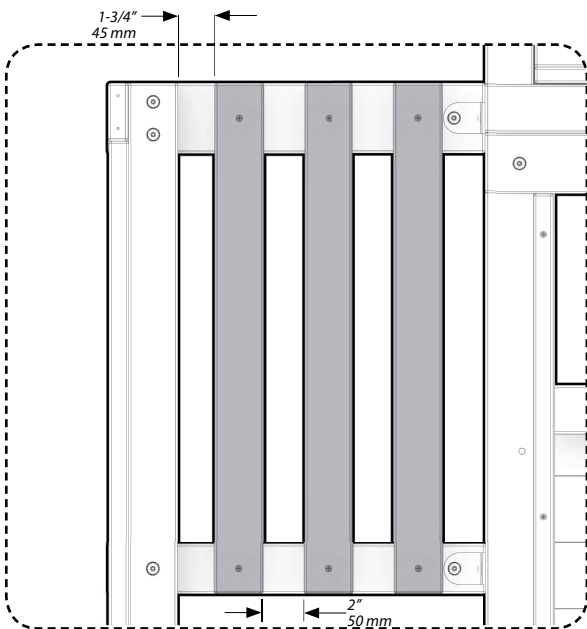
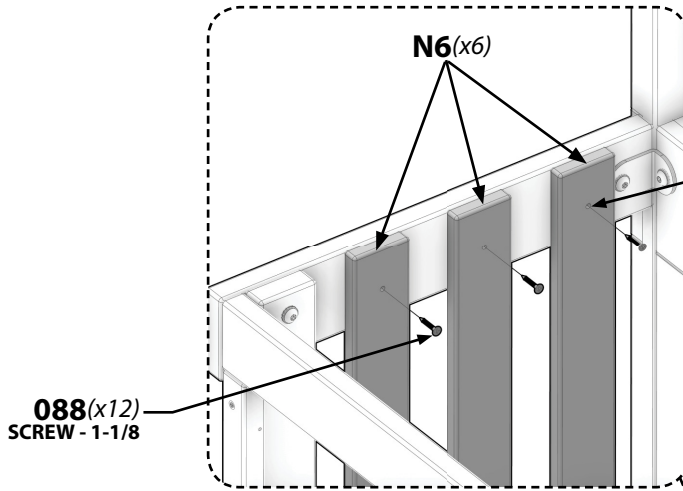

**PICKET PLACEMENT**

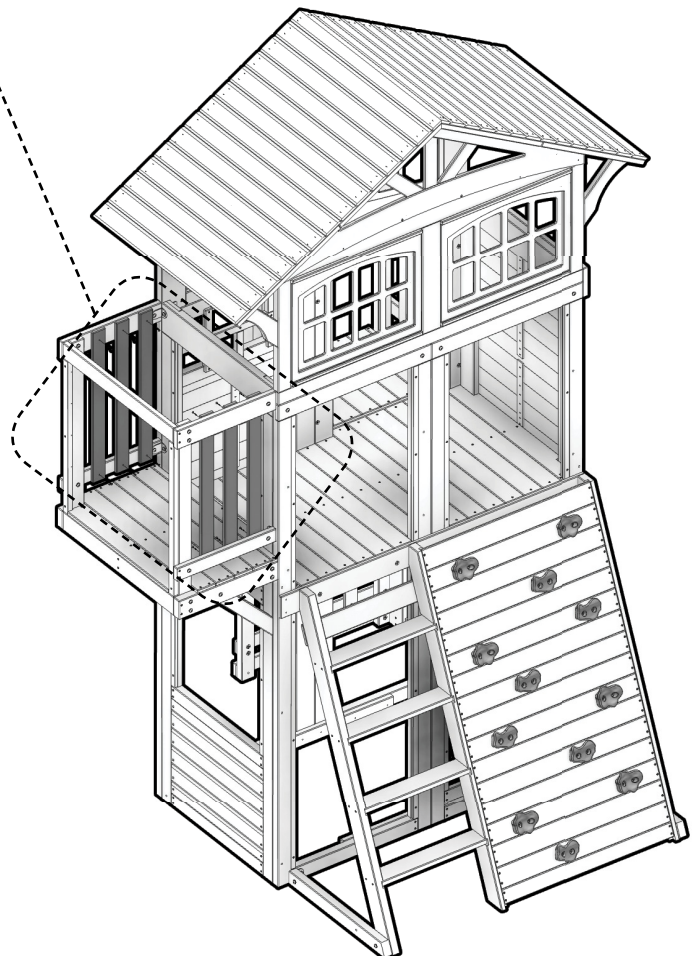



# Phase 7

## STEP 1



**J5** | **BRACE - W4L12468**  
(x2) | 1" x 2-3/8" x 4-1/2" (24 x 60 x 115)



**J6** | **BRACE - W4L12469**  
(x2) | 1" x 2-3/8" x 5-1/8" (24 x 60 x 130)



**H100201** | **SCREW PFH BLK**  
(x8) | 8x2-1/2 - H100201

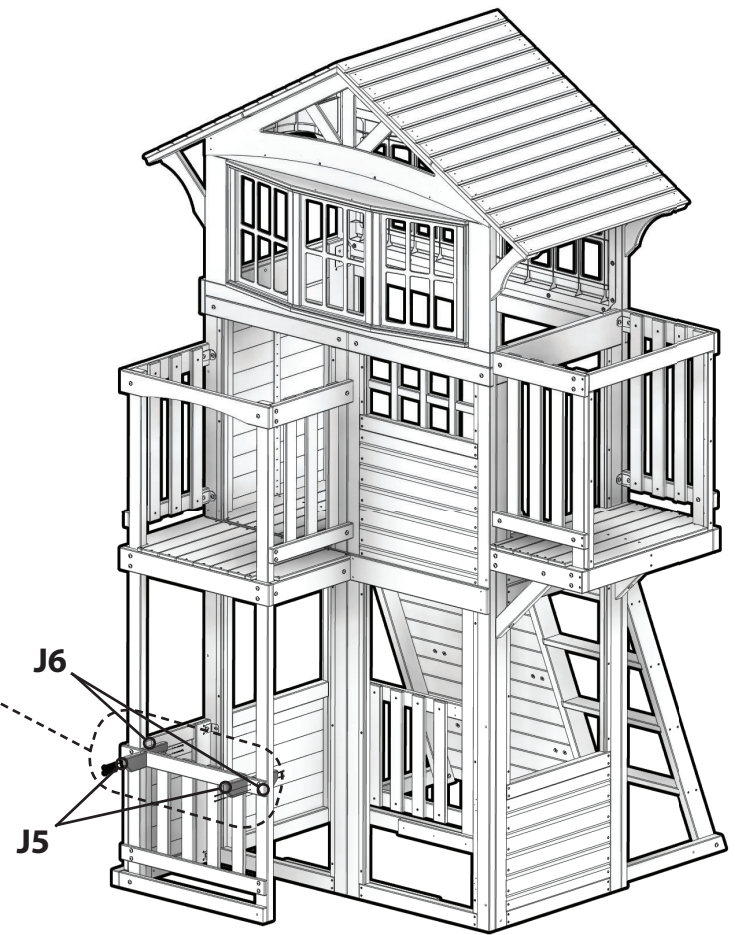
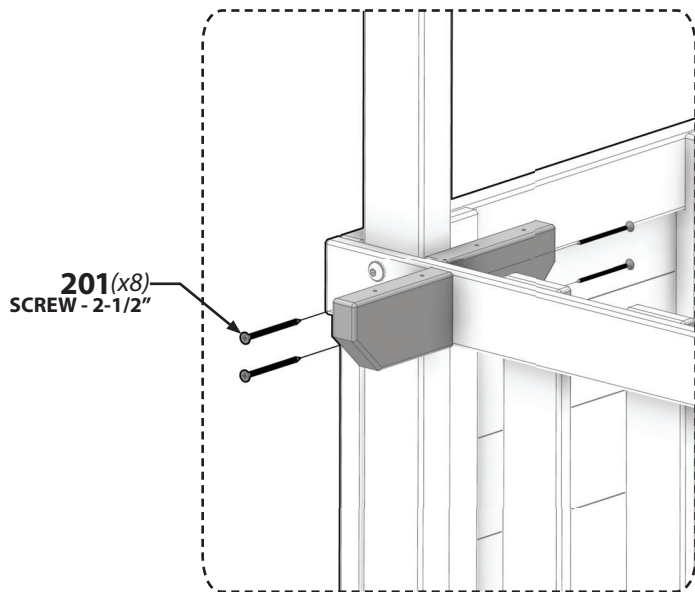



# Phase 7

## STEP 2



**K2**  
(x1)

**COUNTER TOP - W4L12461**  
5/8" x 5-1/4" x 28-3/8" (16 x 134 x 720)

**K3**  
(x1)

**COUNTER TOP - W4L12464**  
5/8" x 5-1/4" x 27-3/8" (16 x 134 x 696)

**H100086** | **SCREW PFH**  
(x8) | 8x1-1/2 - H100086

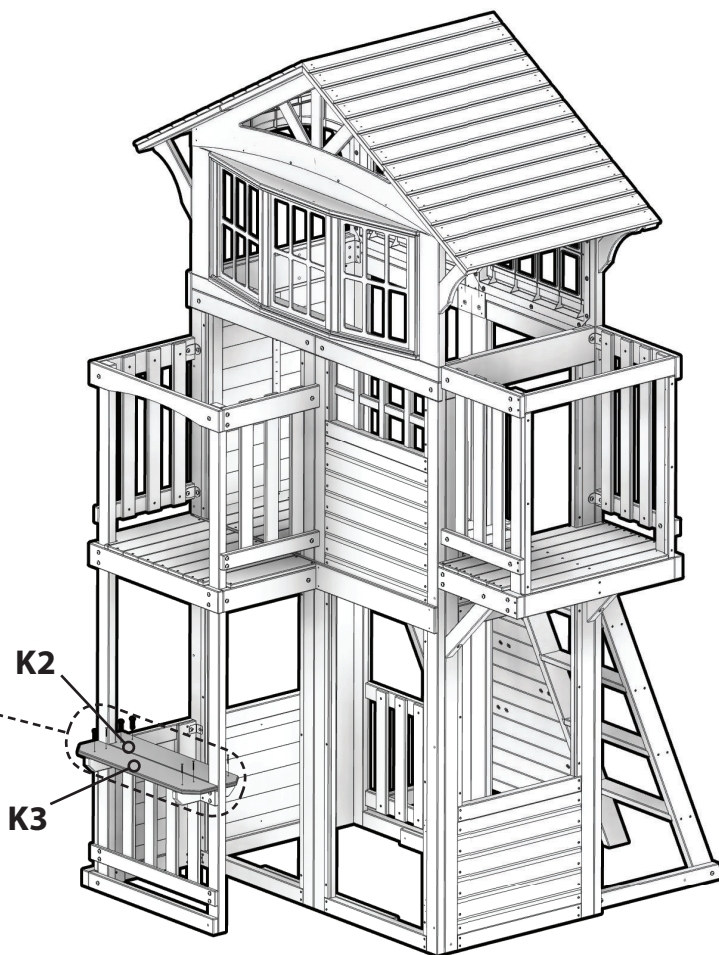
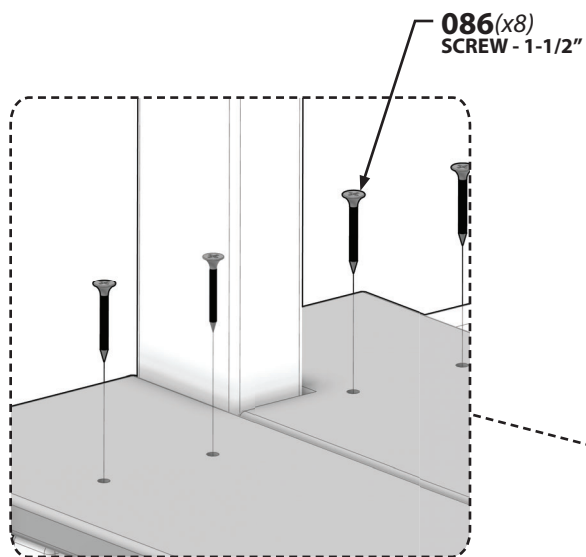



# Phase 7

## STEP 3

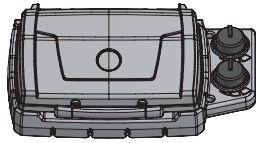

**A6P00282** | **BBQ GRILL**  
(x1) | A6P00282



**H100202** | **SCREW PWH BLK**  
(x4) | 8x5/8 - H100202



**ASSEMBLY NOTE:**  
CENTER GRILL IN OPENING

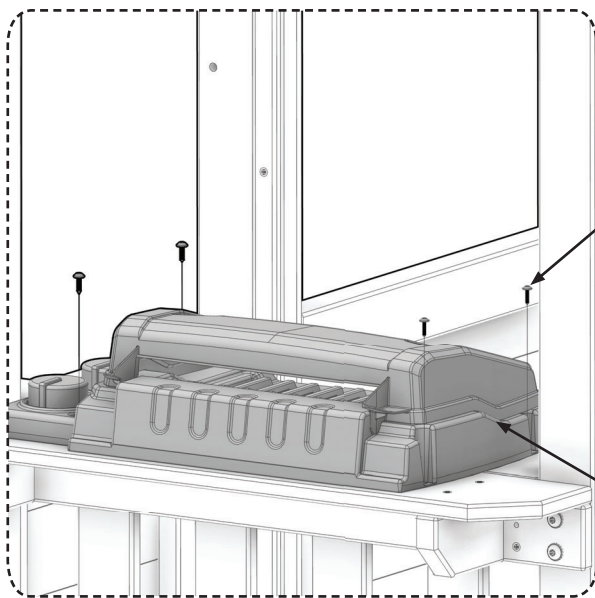
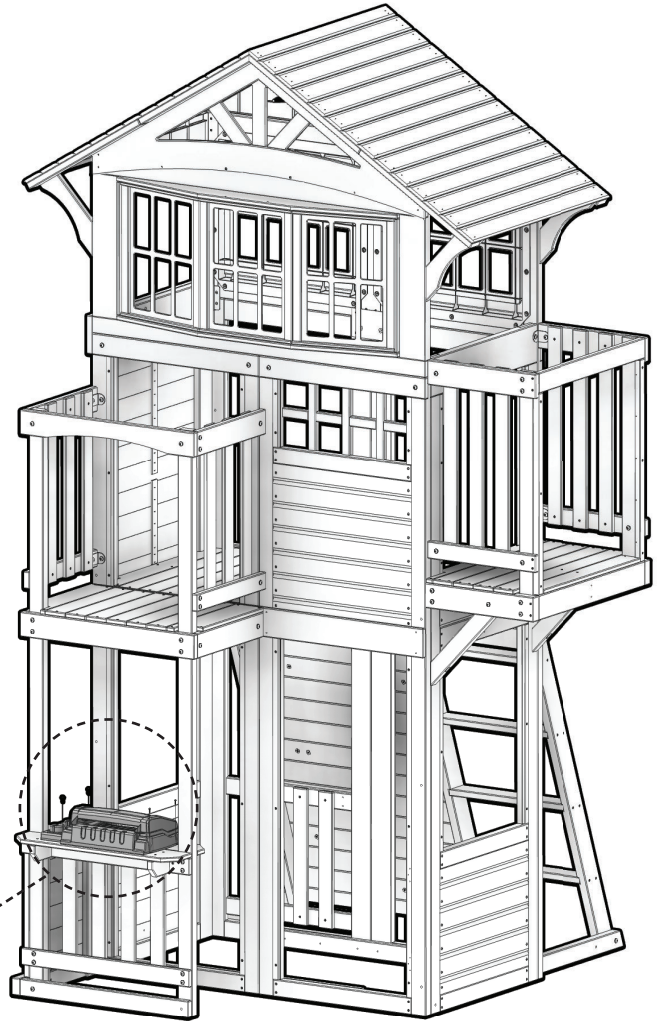

**202(x4)**  
**SCREW - 5/8"**

**282**



# Phase 7

# STEP 4

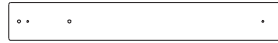
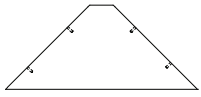

**H100087** | **SCREW PFH**  
 (x2) | 8x1-1/4 - H100087

**H100089** | **SCREW PFH**  
 (x2) | 8x1-3/4 - H100089

**G1** | **ANGLE BRACE - W4L12473**  
 (x1) | 1" x 5-1/4" x 12" (24 x 134 x 305)

**J8** | **BRACE - W4L12472**  
 (x1) | 1" x 2-3/8" x 17-1/8" (24 x 60 x 434)

 **ASSEMBLY NOTE:**  
 PRE-ASSEMBLE 'J8' BRACE TO 'G1' ANGLE BRACE.

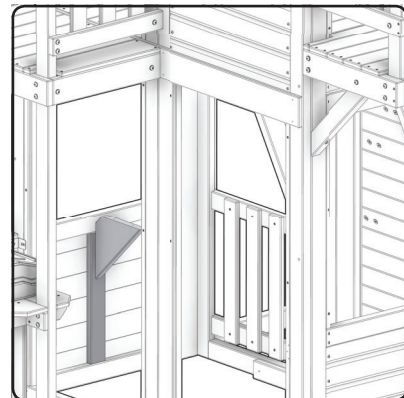
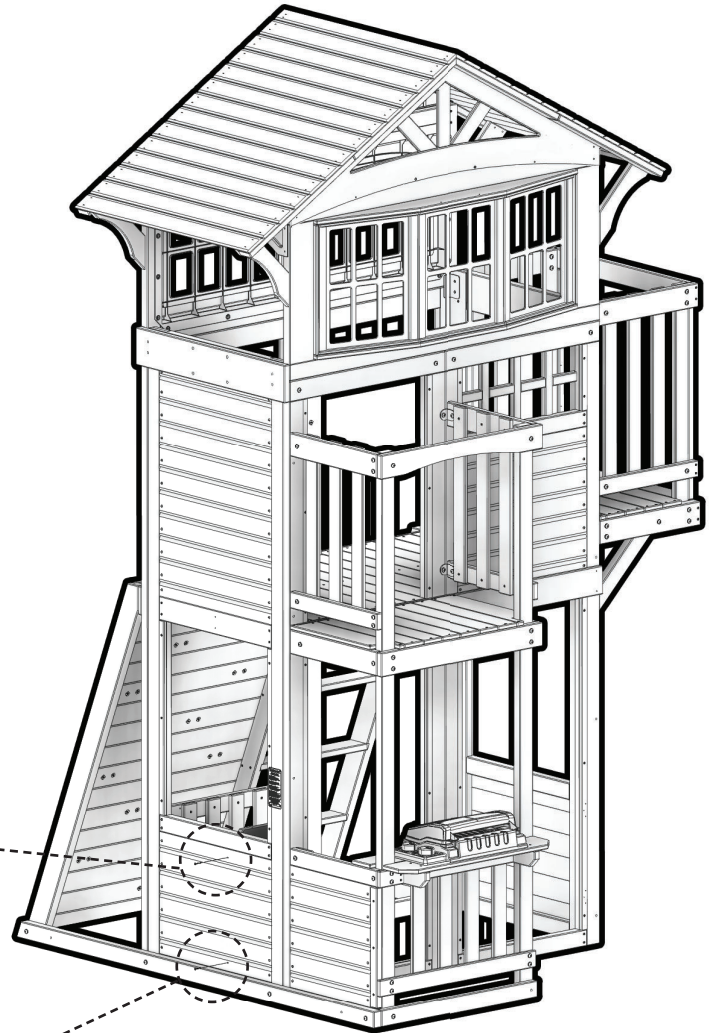
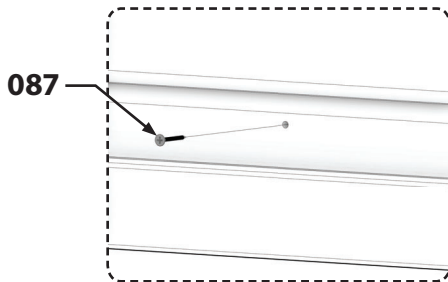
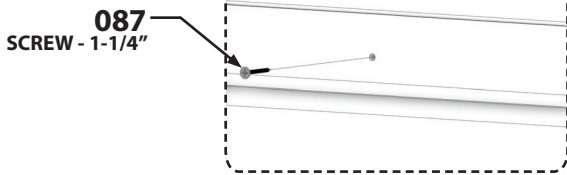
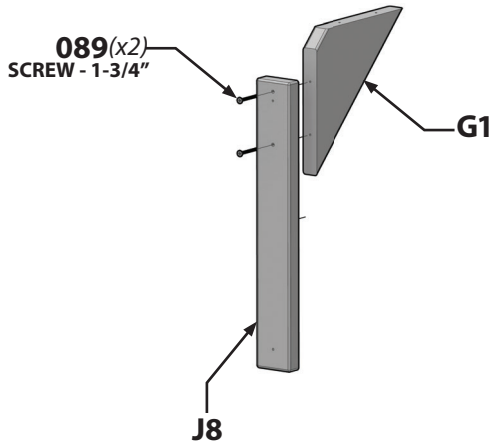

**INSIDE VIEW**



# Phase 7

## STEP 5

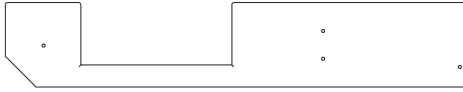

**K4** | COUNTER TOP - W4L12465  
(x1) 5/8" x 5-1/4" x 28-3/4" (16 x 134 x 730)

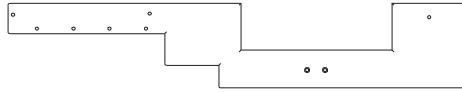

**K5** | COUNTER TOP - W4L12466  
(x1) 5/8" x 5-1/4" x 28-3/4" (16 x 134 x 730)

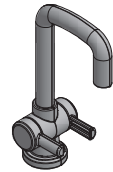

**A6P00333** | FAUCET  
(x1) A6P00333



**H100085** | SCREW PFH  
(x2) 8x1 - H100085



**H100086** | SCREW PFH  
(x7) 8x1-1/2 - H100086



**ASSEMBLY NOTE:**  
PRE-ASSEMBLE FAUCET TO 'K5' COUNTER TOP.

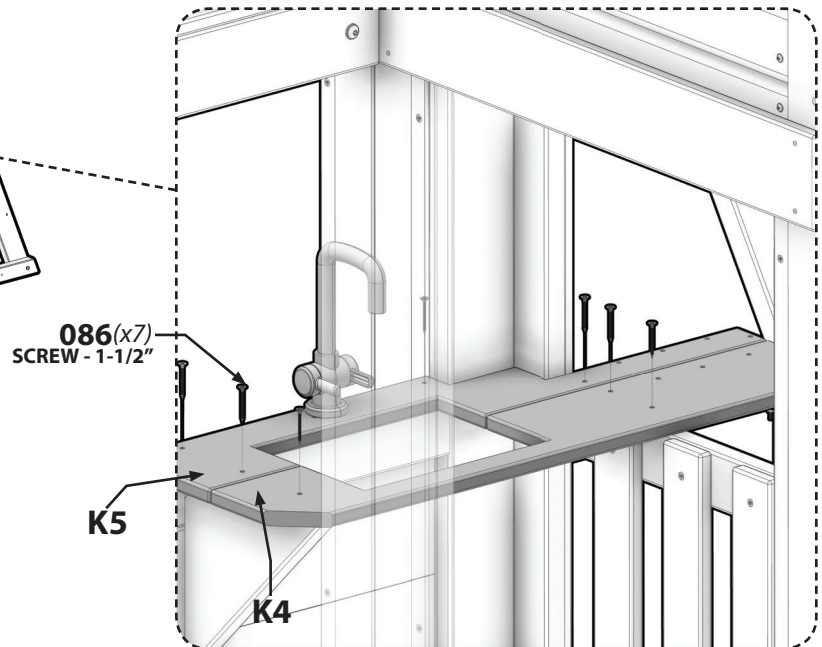
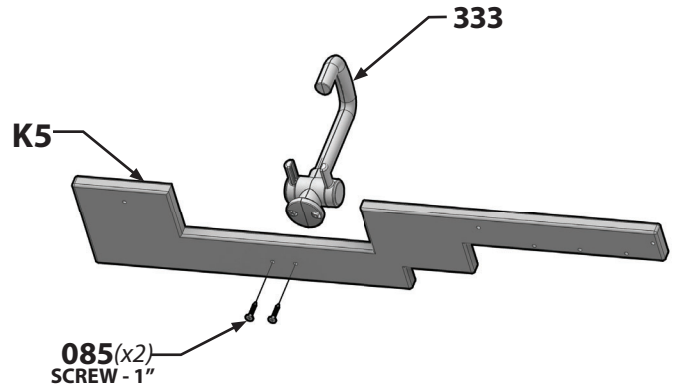
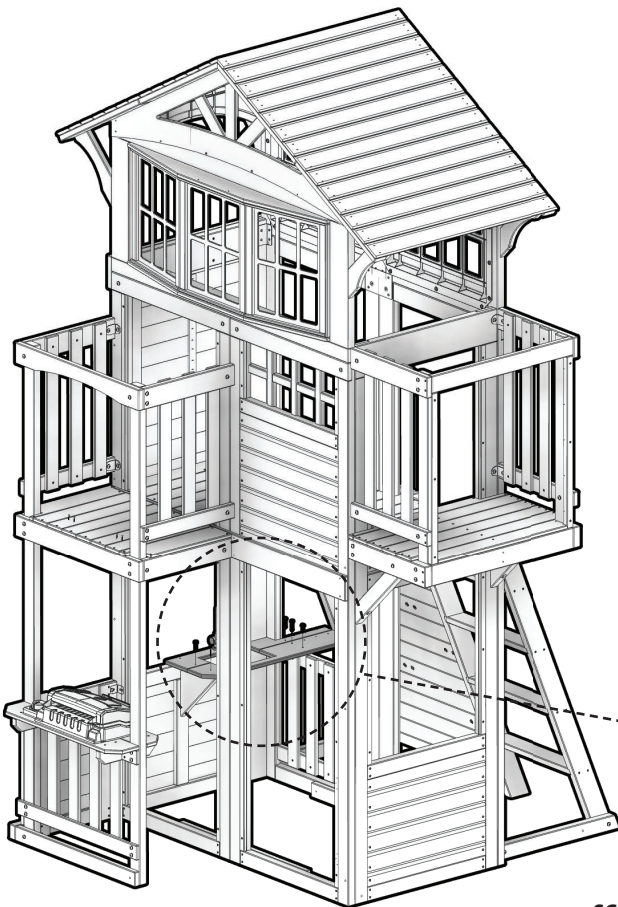



**J13** | **BRACE - W4L12474**  
(x2) | 1" x 2-3/8" x 7-7/8" (24x60x200)



**H100088** | **SCREW PFH**  
(x3) | 8x1-1/8 - H100088



**H100090** | **SCREW PFH**  
(x4) | 8x2-1/2 - H100090

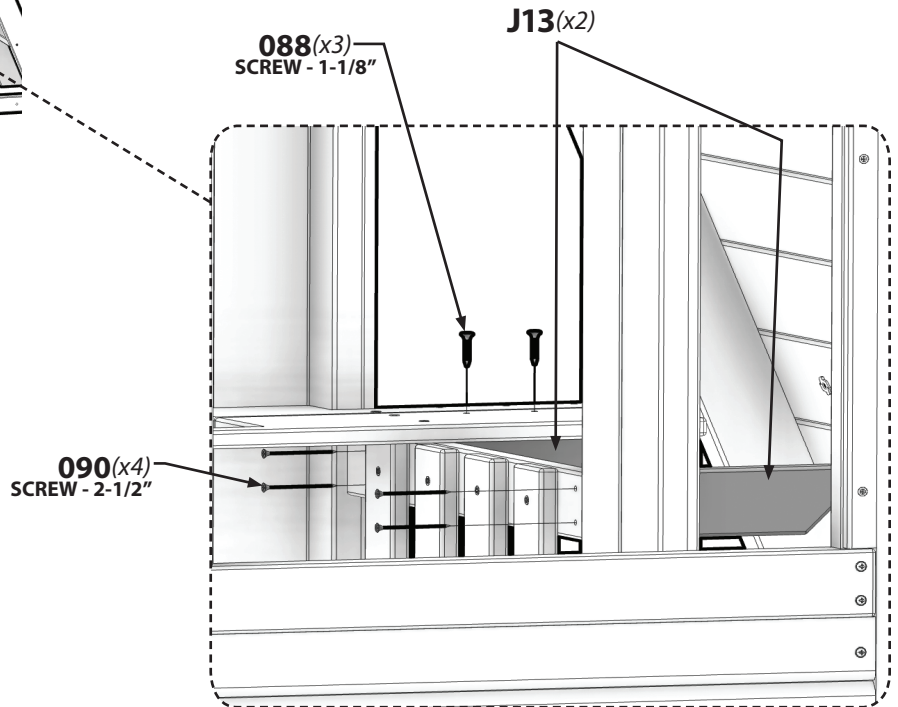
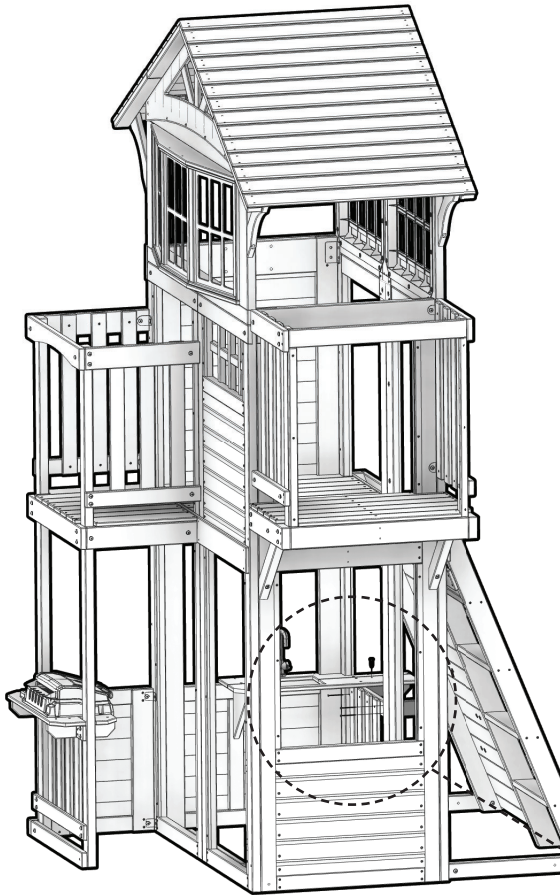

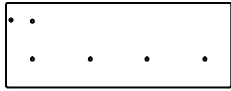

**K6**  
(x1) | **COUNTERTOP - W4L12467**  
5/8" x 5-1/4" x 14-1/8" (16 x 134 x 358)



**K7**  
(x1) | **COUNTERTOP - W4L12475**  
5/8" x 5-1/4" x 14-1/8" (16 x 134 x 358)



**H100088** | **SCREW PFH**  
(x7) | 8x1-1/8 - H100088



**ASSEMBLY NOTE:**  
MAKE BOARDS "K6" AND "K7" FLUSH.

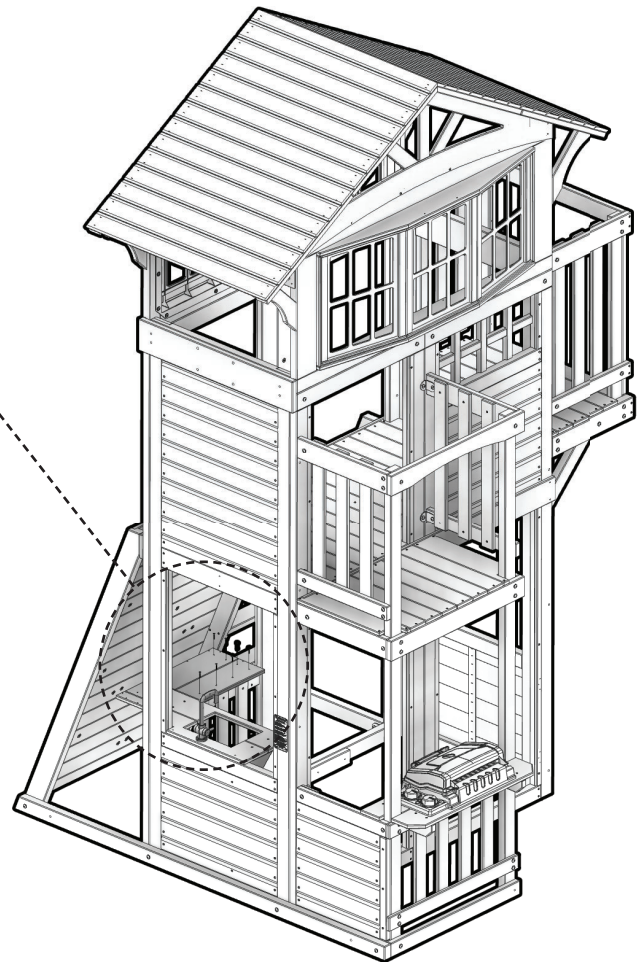
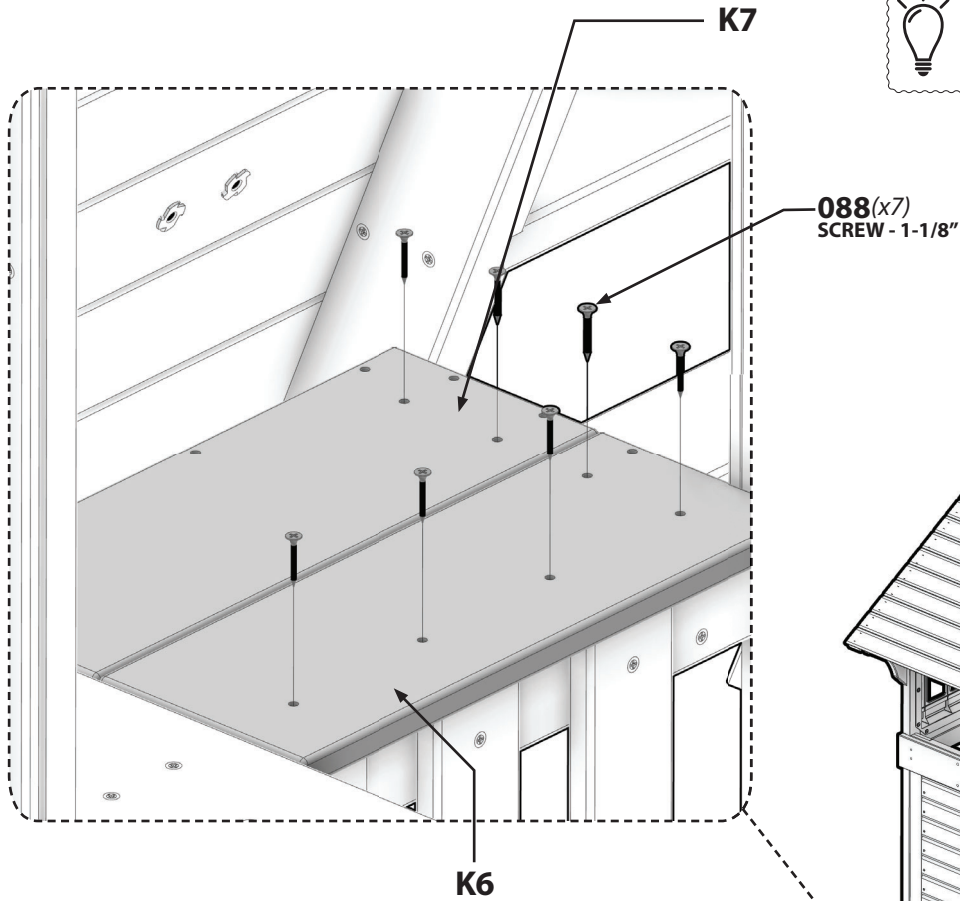



**O1** | TRIM - W4L12476  
(x1) | 5/8" x 1-3/8" x 21-1/4" (16 x 34 x 540)



**H100087** | SCREW PFH  
(x4) | 8x1-1/4 - H100087

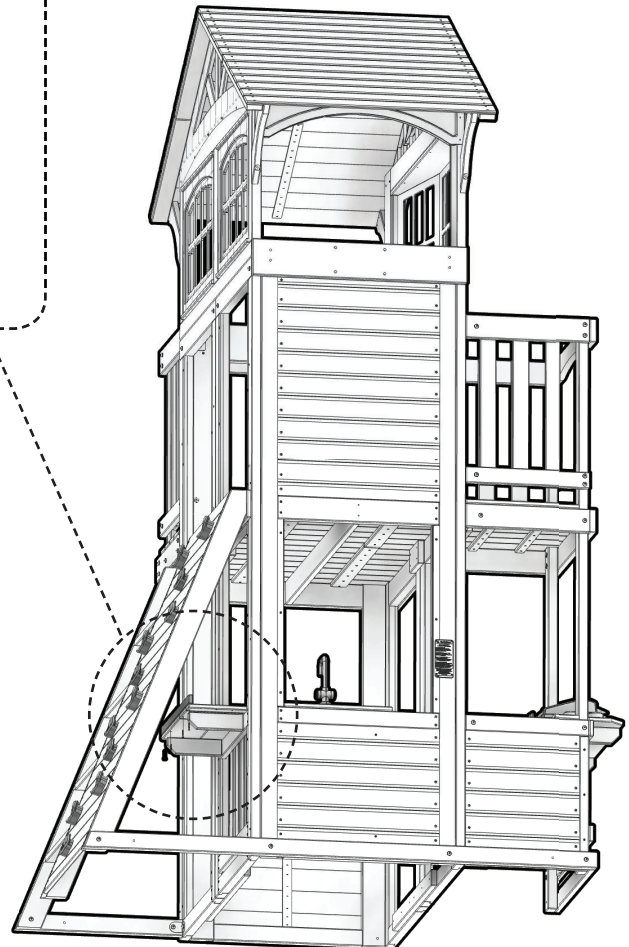
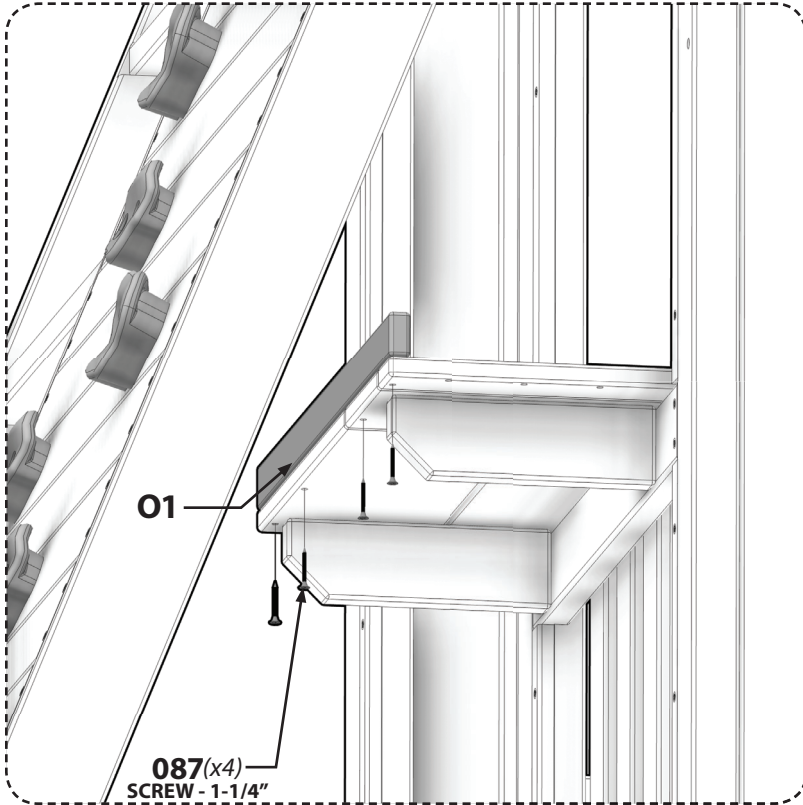



# Phase 7

# STEP 9

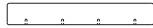

**O2** | TRIM - W4L12477  
(x1) | 5/8" x 1-3/8" x 9-1/8" (16 x 34 x 233)



**H100087** | SCREW PFH  
(x3) | 8x1-1/4 - H100087

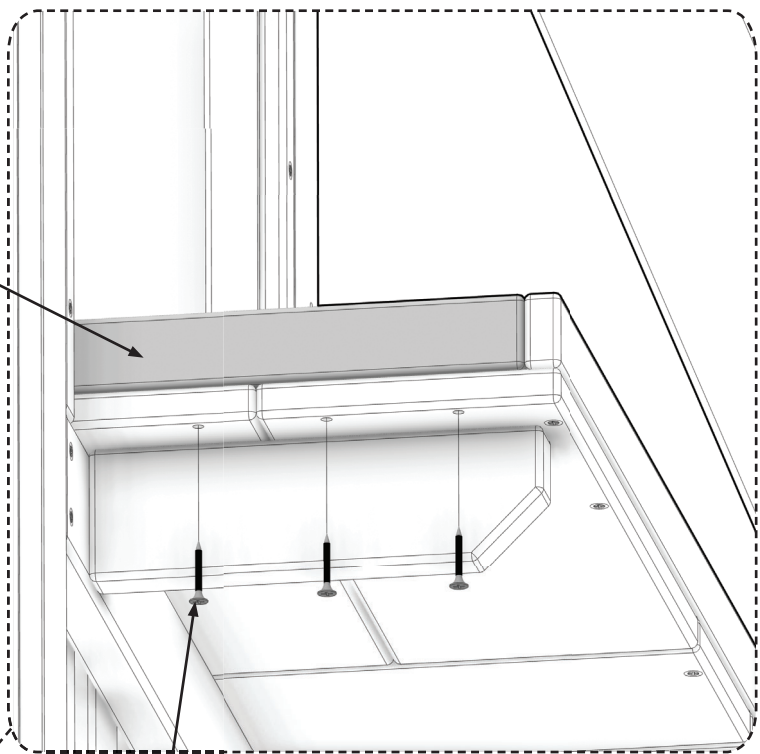
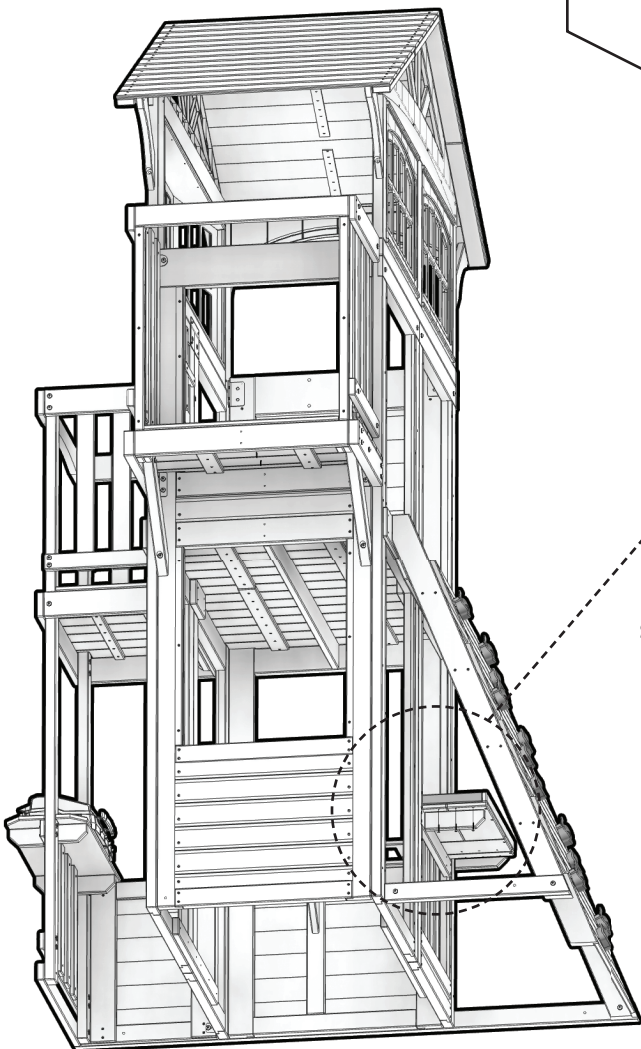

**O2**

**087(x3)**  
SCREW - 1-1/4"

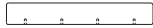

**O2** | TRIM - W4L12477  
(x1) | 5/8" x 1-3/8" x 9-1/8" (16 x 34 x 233)



**H100087** | SCREW PFH  
(x3) | 8x1-1/4" - H100087

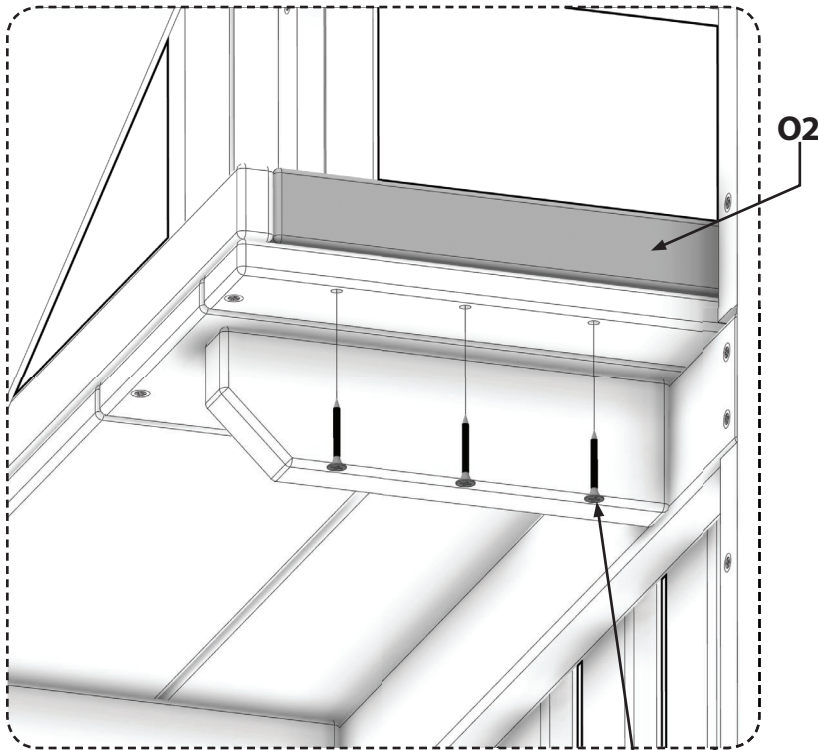

**087(x3)**  
SCREW - 1-1/4"

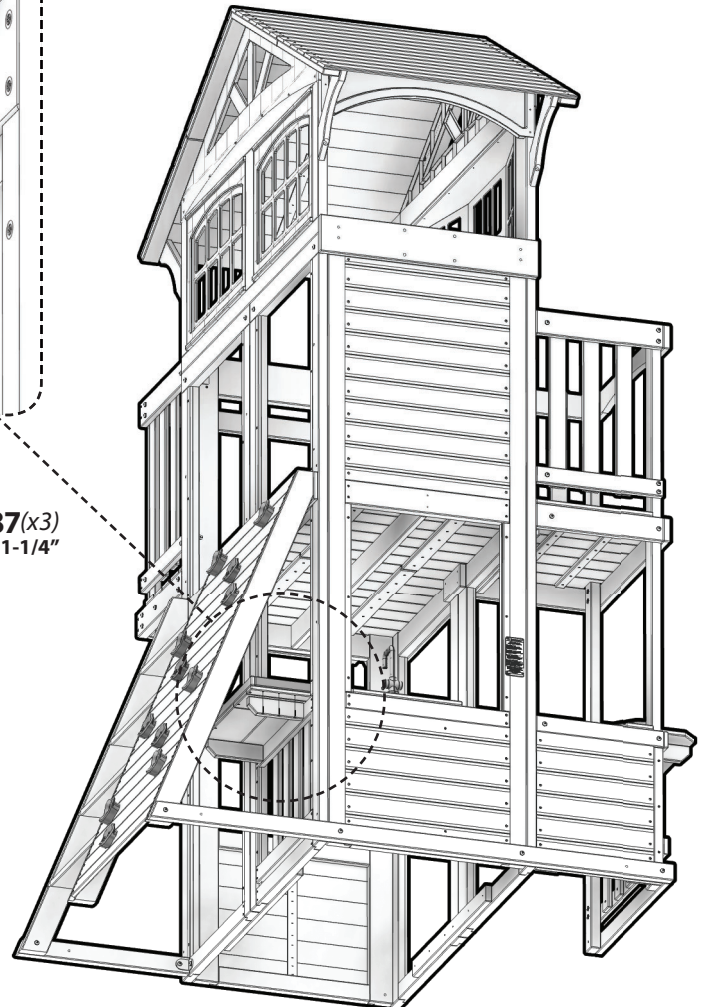



# Phase 7

## STEP 11

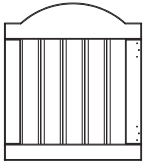

**DP1** | **DOOR PANEL - W2A02773**  
(x1) 1-1/16" x 20" x 22-15/16" (27 x 508 x 582)

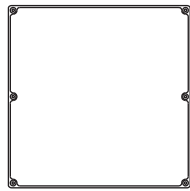

**A6P00323** | **CHALK BOARD**  
(x1) A6P00323



**A100327** | **HINGE, SPRING LOADED**  
(x1) A100327



**A4M00558** | **HINGE, NON-SPRING LOADED**  
(x1) A4M00558



**H100202** | **SCREW PWH BLK**  
(x6) 8x5/8 - H100202



**H100385** | **SCREW PFH BLK**  
(x6) 8x1 - H100385

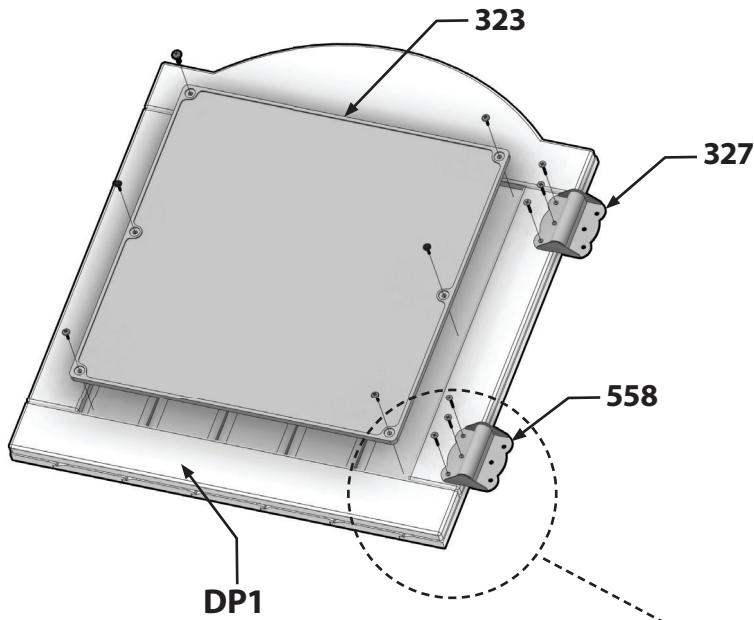

REFERENCE VIEW

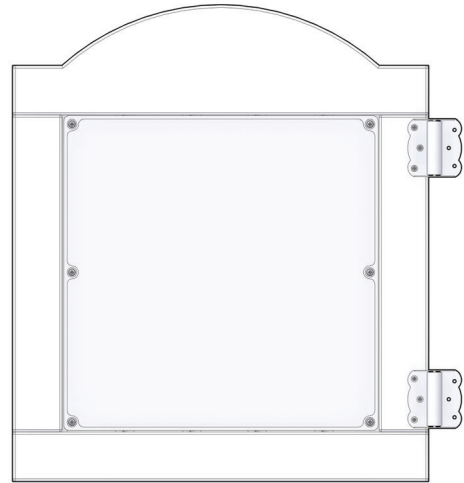

**DOOR ASSEMBLY**

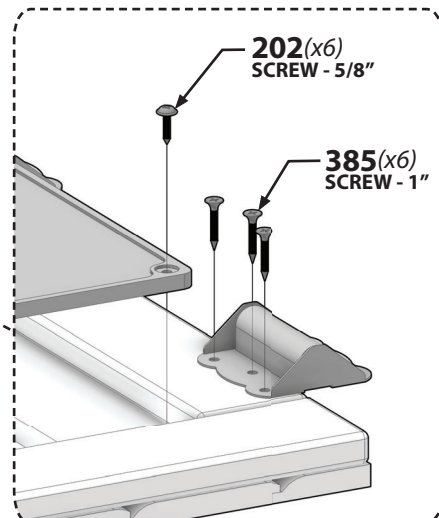

**202(x6)**  
**SCREW - 5/8"**

**385(x6)**  
**SCREW - 1"**

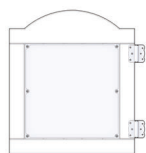

**DOOR ASSEMBLY**



**H100385** | **SCREW PFH BLK**  
(x6) | 8x1 - H100385

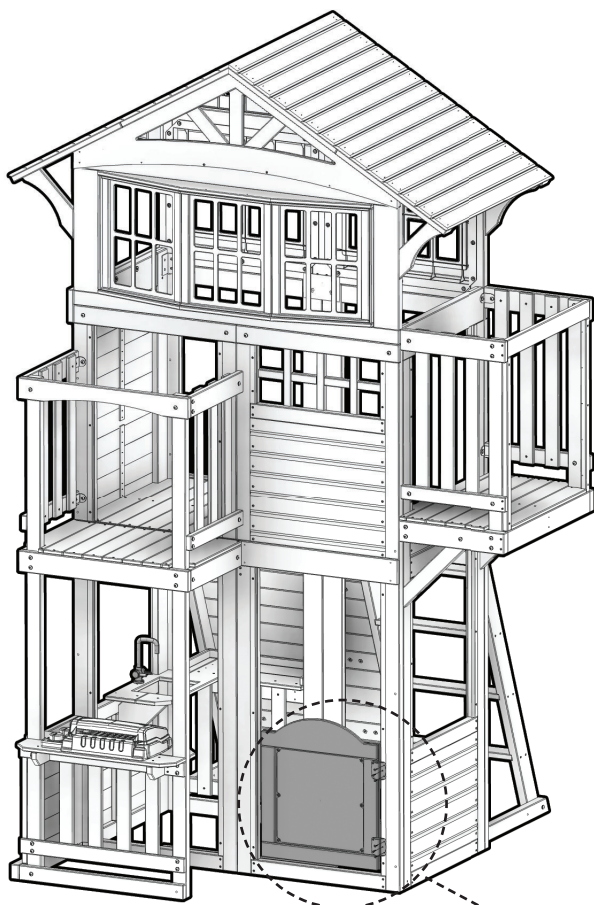

**DOOR ASSEMBLY**

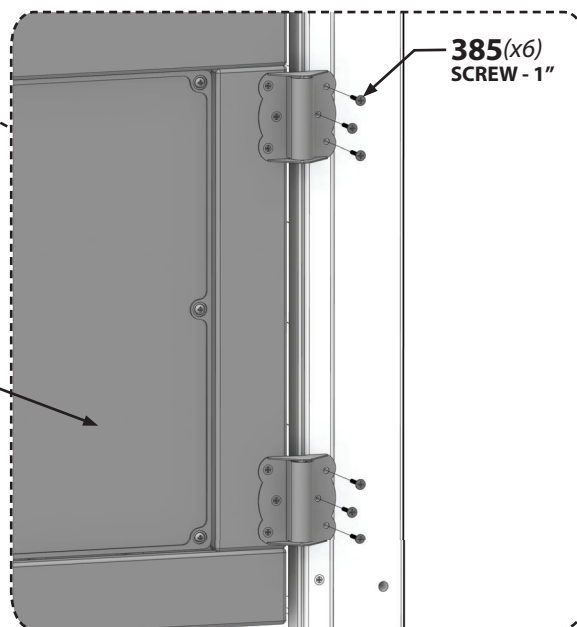



**J10** | **DOOR BLOCK - W4L12480**  
(x1) | 1"x2-3/8"x4-1/2" (24x60x115)



**H100088** | **SCREW PFH**  
(x3) | 8x1-1/8 - H100088

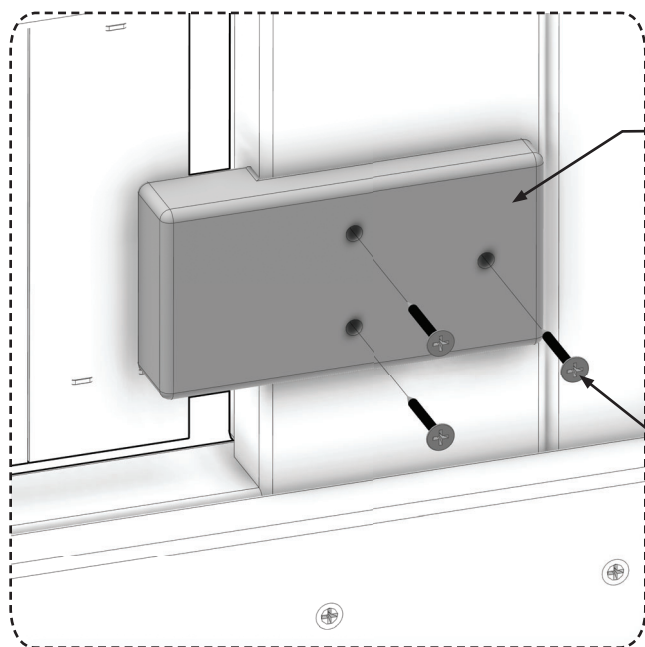
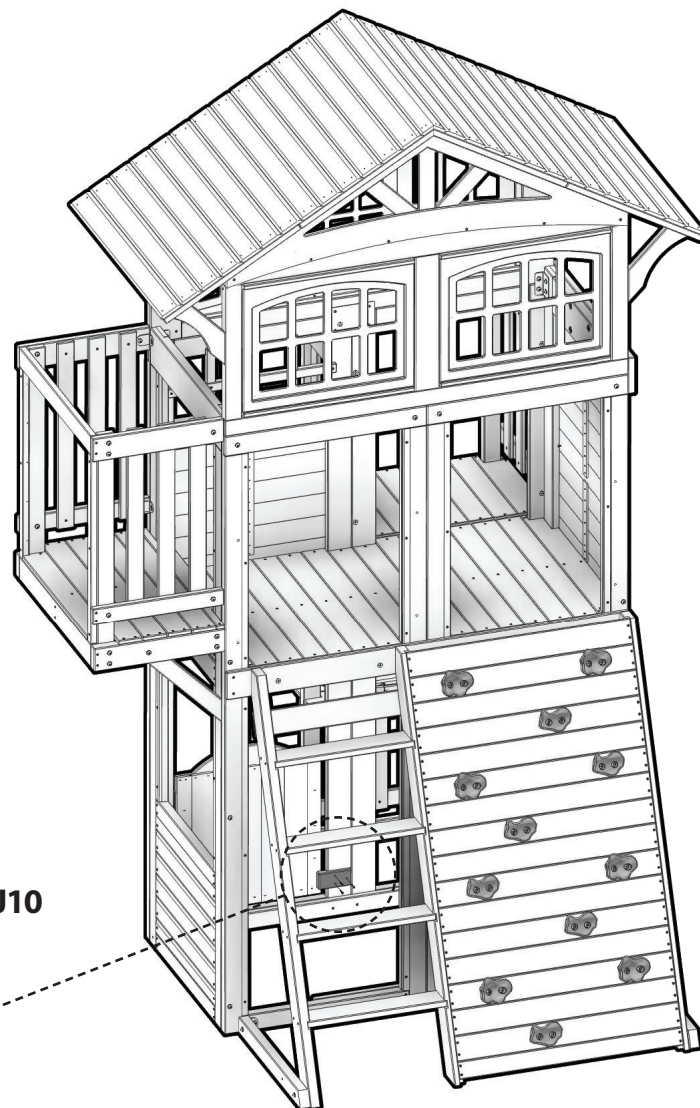

**J10**

**088(x3)**  
**SCREW - 1-1/8"**

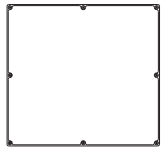

**A6P00324** | **CHALK BOARD LARGE**  
(x1) | A6P00324



**H100202** | **SCREW PWH BLK**  
(x8) | 8x5/8 - H100202

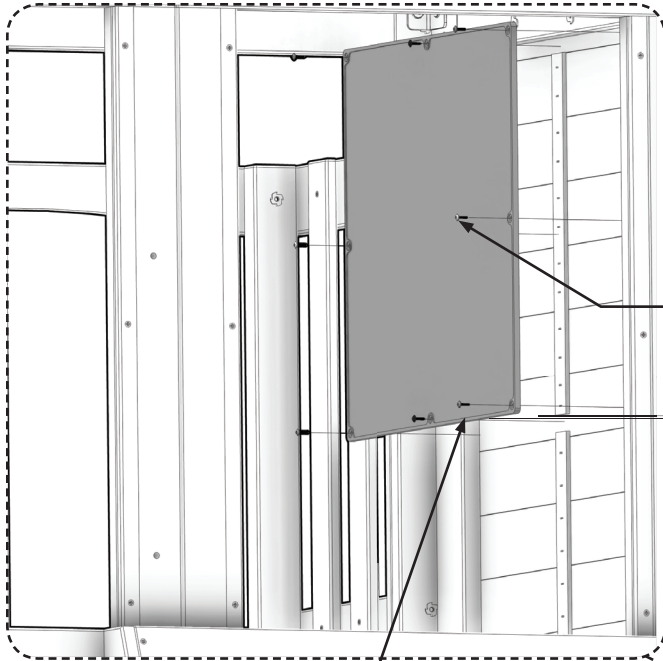

**202(x8)**  
**SCREW - 5/8"**

**3/4" OR 19 mm**

**324**

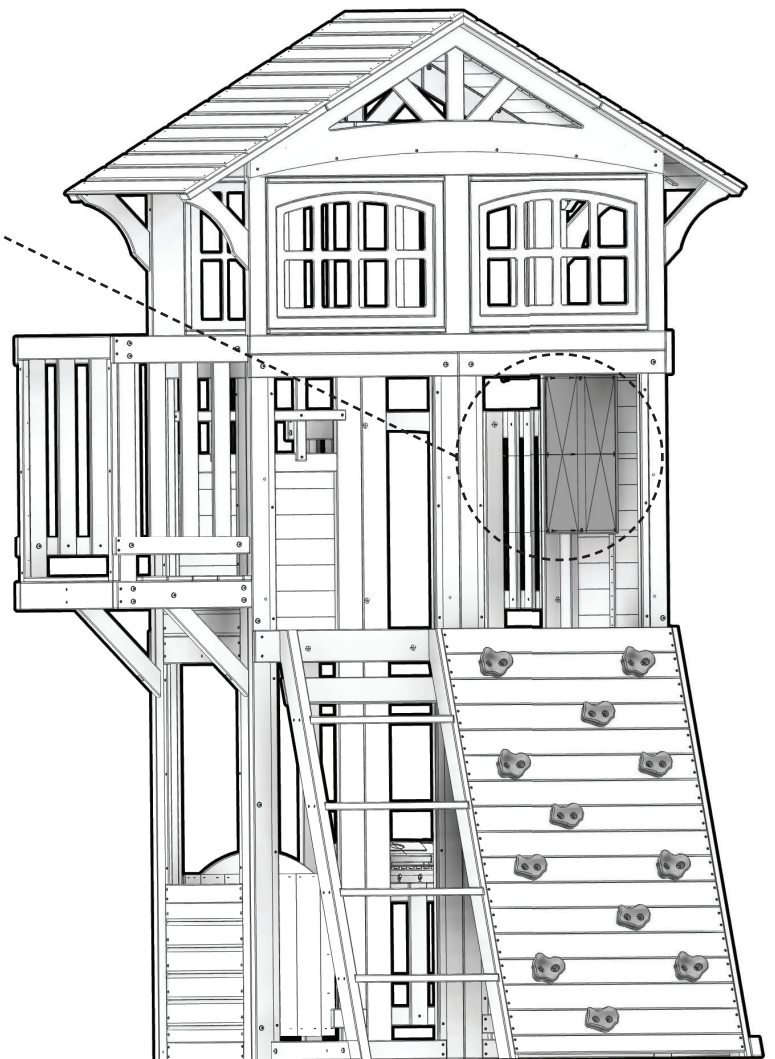



A4M00554 | BELL ASSEMBLY  
(x1) A4M00554



H100202 | SCREW PWH BLK  
(x2) 8x5/8 - H100202



**ASSEMBLY NOTE:**

BELL SHOULD BE PUSHED UP UNDER BOARD "H6".

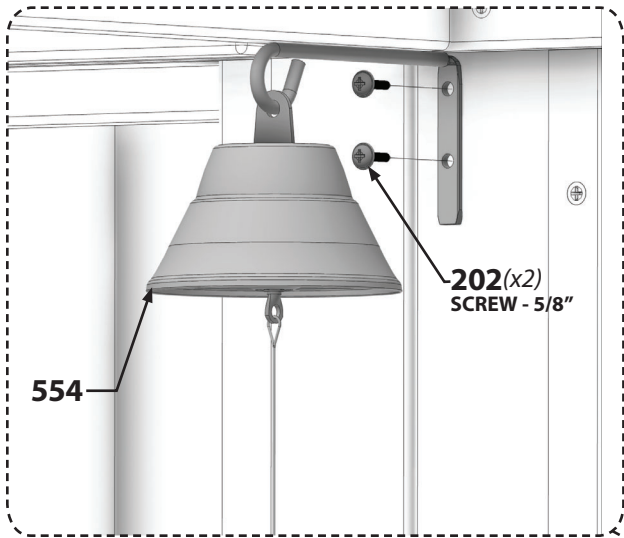



**O3** | **BLOCK - W4L12603**  
 (x1) | 5/8"x1 3/8"x3 7/8" (16x34x100)



**A100107** | **STEERING WHEEL KIT**  
 (x1) | A100107



**H100087** | **SCREW PFH**  
 (x2) | 8x1-1/4 - H100087

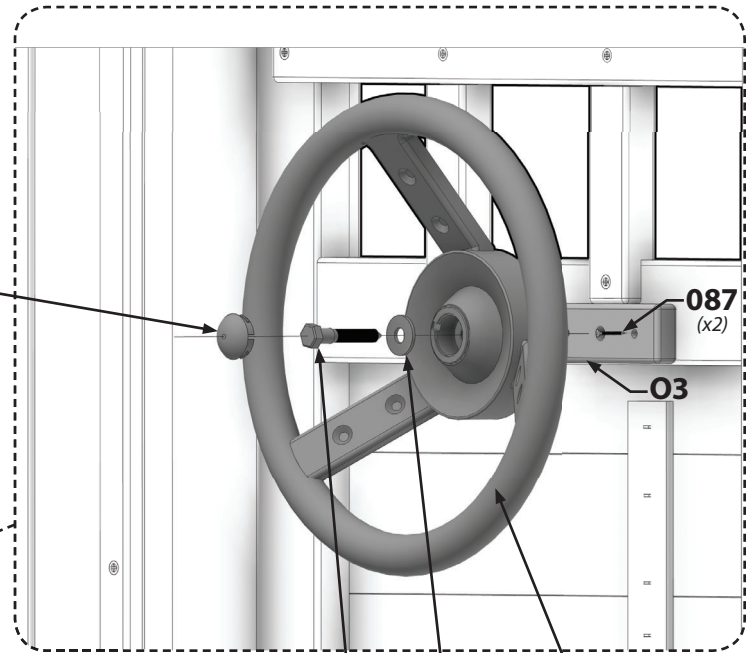

**CENTER CAP**

**087**  
(x2)

**O3**

**107**

**LAG SCREW HEX 5/16x2**  
(INCLUDED IN KIT)

**WASHER FLAT 8x12**  
(INCLUDED IN KIT)



# Phase 7

# STEP 17

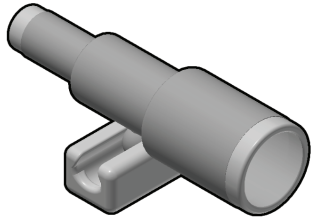

**A6P00096** | TELESCOPE  
(x1) | A6P00096



**H100087** | SCREW PFH  
(x2) | 8x1-1/4 - H100087

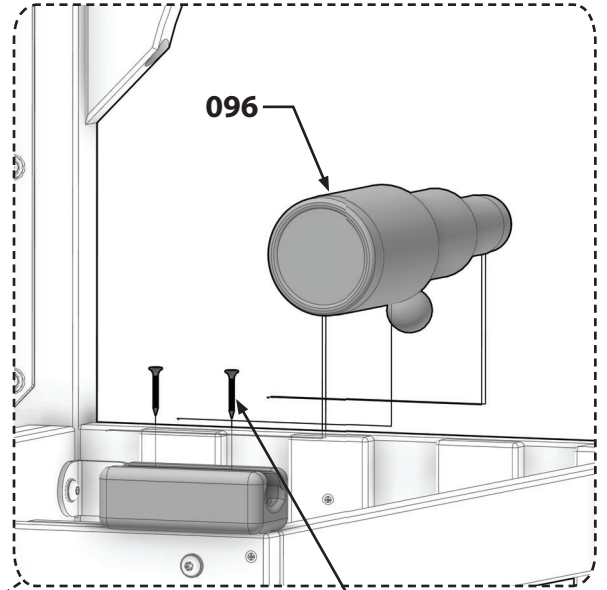
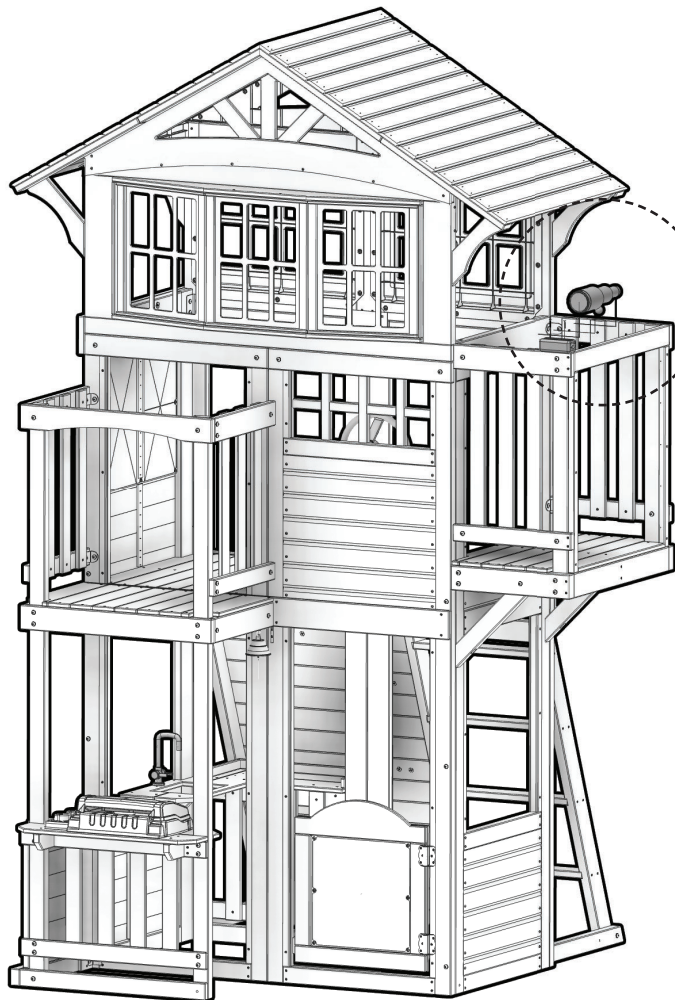

**087(x2)**  
SCREW - 1-1/4"

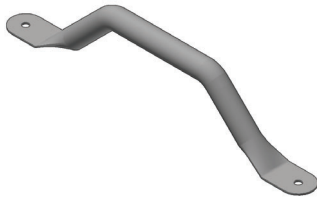

**A100118** | **HAND GRIP**  
(x3) | A100118

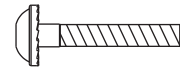

**H100406** | **BOLT WH BLK**  
(x6) | 1/4x1-1/2-H100406

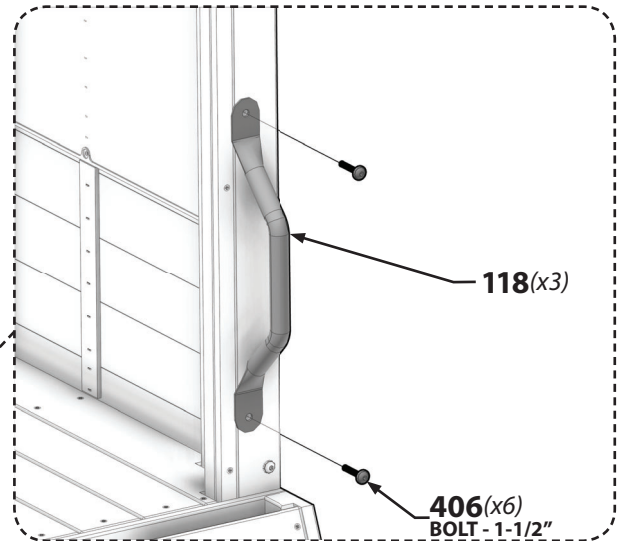
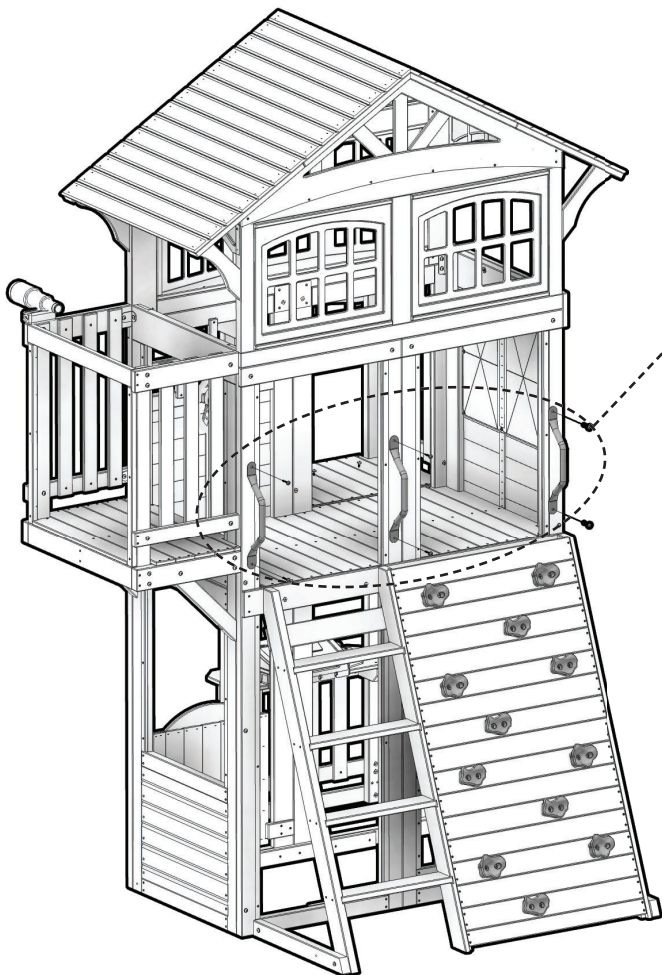

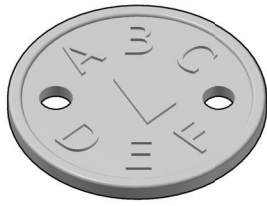

**A100314** | 'A' REVISIONTAG  
(x1) | A100314



**H100202** | SCREW PWH BLK  
(x2) | 8x5/8 - H100202

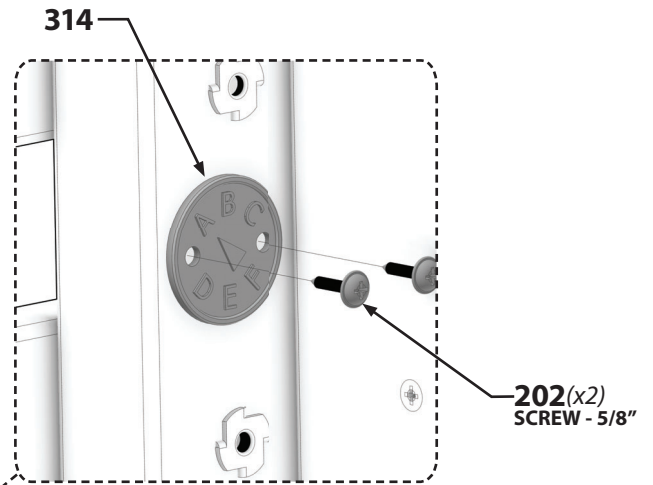
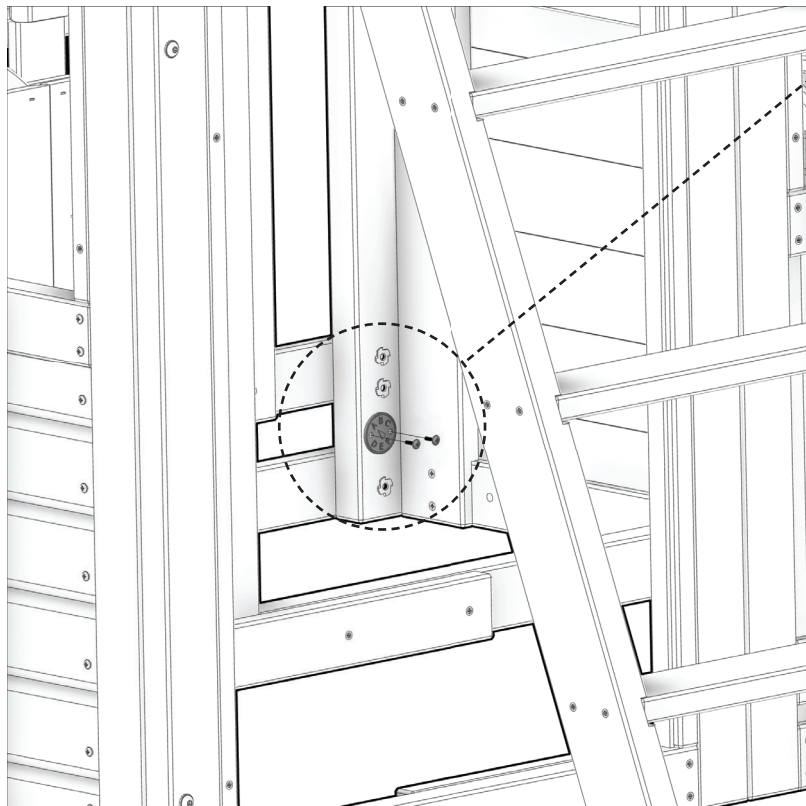

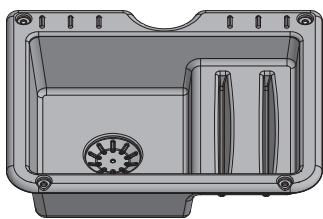

**A6P00332** | PREMIUM SINK  
(x1) A6P00332



**H100202** | SCREW PWH BLK  
(x4) 8x5/8 - H100202

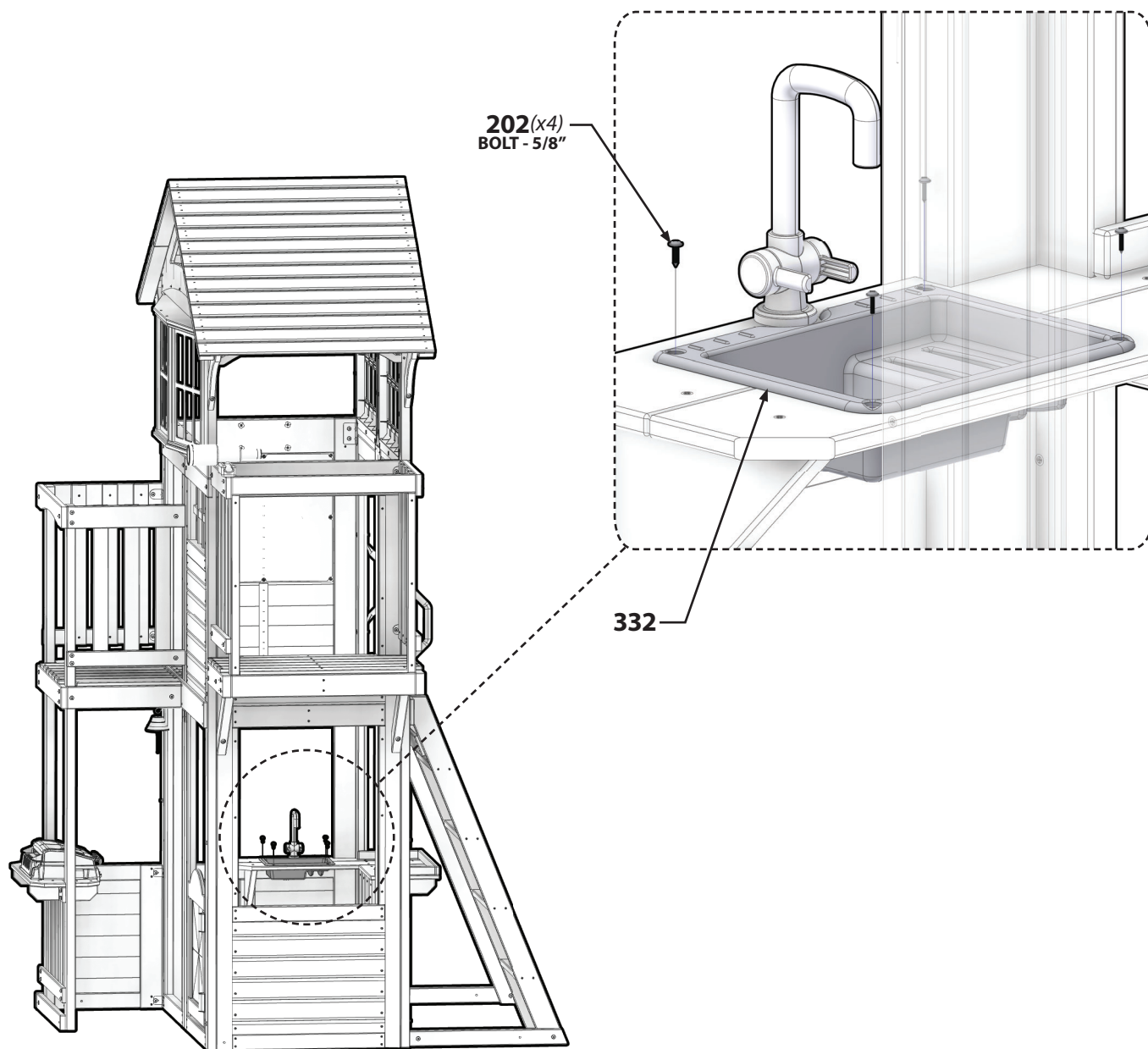

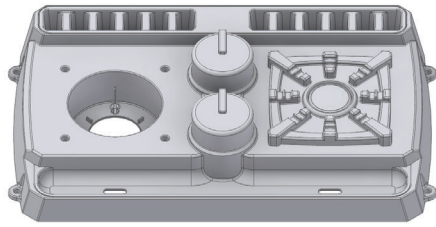

A6P00335 | STOVE BASE  
(x1) | A6P00335

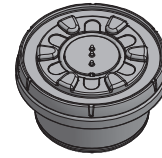

A6P00330 | INDUCTIVE BURNER KIT  
(x1) | A6P00330

FCC LABEL

**NOTE: THIS DEVICE COMPLIES WITH PART 15 OF THE FCC RULES. OPERATION IS SUBJECT TO THE FOLLOWING TWO CONDITIONS: (1) THIS DEVICE MAY NOT CAUSE HARMFUL INTERFERENCE (2) THIS DEVICE MUST ACCEPT ANY INTERFERENCE RECEIVED, INCLUDING INTERFERENCE THAT MAY CAUSE UNDESIRED OPERATION.**

**TWIST TO LOCK  
IN PLACE.**

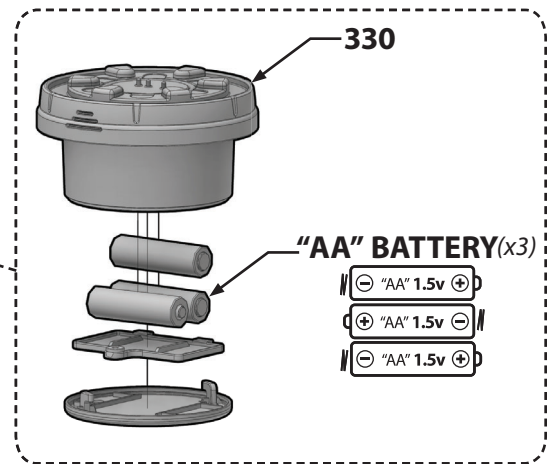
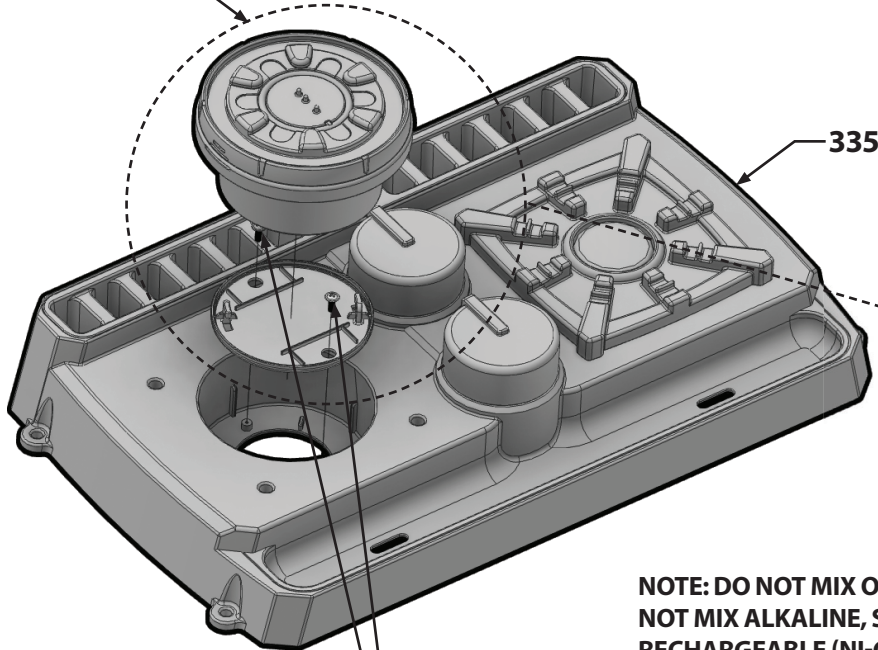

**NOTE: DO NOT MIX OLD AND NEW BATTERIES AND DO NOT MIX ALKALINE, STANDARD (CARBON-ZINC) OR RECHARGEABLE (NI-CAD, NI-MH, ETC.) BATTERIES.**

**USE THE #4X5/8" SCREWS INCLUDED WITH STOVE KIT TO ASSEMBLE BOTTOM PLATE OF ROUND INDUCTION BURNER..**



CLASS B DIGITAL DEVICE STATEMENT

**Note:**

This equipment has been tested and found to comply with the limits for a Class B digital device, pursuant to part 15 of the FCC Rules. These limits are designed to provide reasonable protection against harmful interference in a residential installation. This equipment generates, uses and can radiate radio frequency energy and, if not installed and used in accordance with the instructions, may cause harmful interference to radio communications. However, there is no guarantee that interference will not occur in a particular installation. If this equipment does cause harmful interference to radio or television reception, which can be determined by turning the equipment off and on, the user is encouraged to try to correct the interference by one or more of the following measures:

- Reorient or relocate the receiving antenna.
- Increase the separation between the equipment and receiver.
- Connect the equipment into an outlet on a circuit different from that to which the receiver is connected.
- Consult the dealer or an experienced radio/TV technician for help

Caution: Changes or modifications not expressly approved by the party responsible for compliance could void the user's authority to operate the equipment.

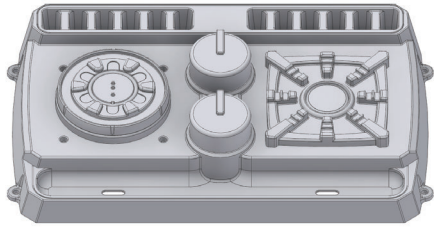

**STOVE ASSEMBLY**



H100202 | SCREW PWH BLK  
(x4) | 8x5/8 - H100202

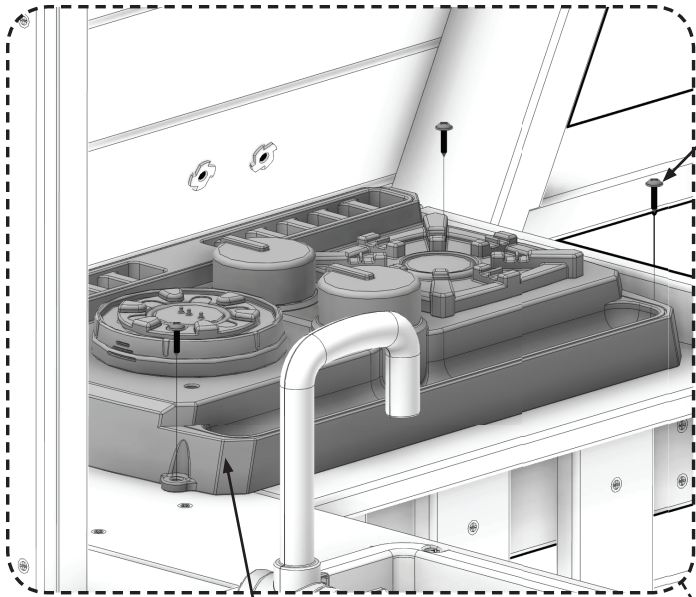

202(x4)  
BOLT - 5/8"

**STOVE ASSEMBLY**

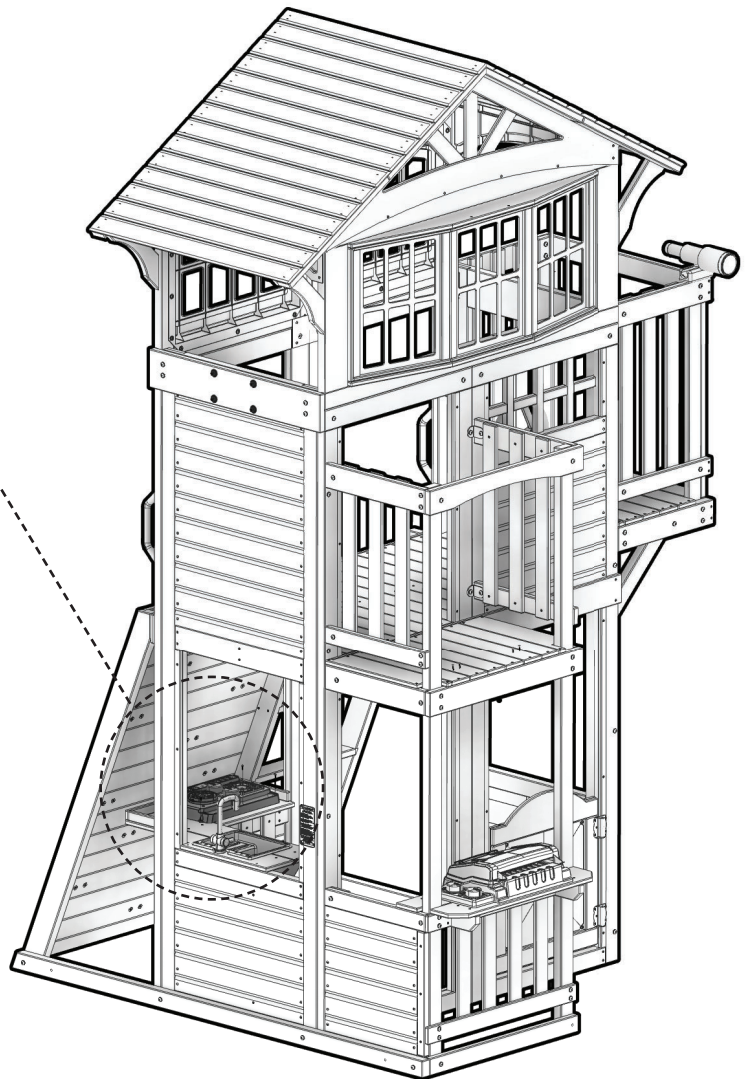

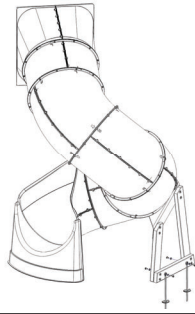

**9198067  
TUBE SLIDE ASSEMBLY**



**H100785** | **SCREW PWH**  
(x18) | 8x1 - H100785



**ASSEMBLY NOTE:**

FOR ASSEMBLY OF THE TUBE SLIDE, PLEASE REFER TO RIGHT EXIT TUBE SLIDE MANUAL.

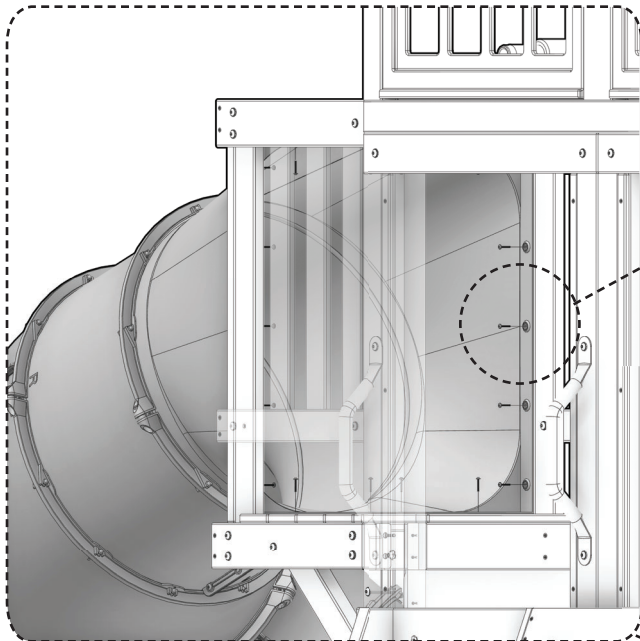

**785(x18)**  
**SCREW-1"**

**9198067  
TUBE SLIDE ASSEMBLY**

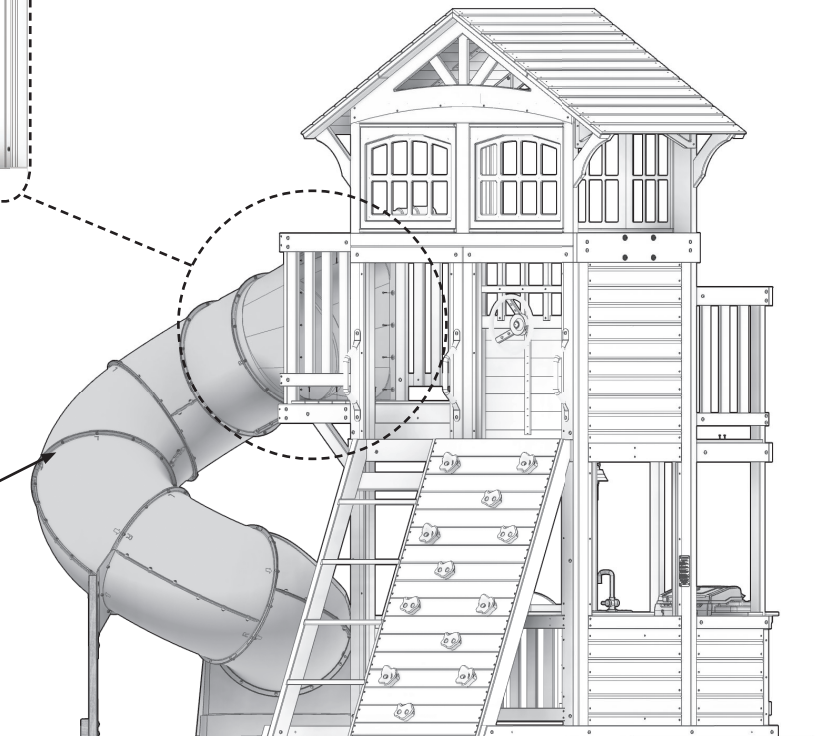



# Phase 8

# STEP 1



**O70** | SLIDE MOUNTING BOARD - W102822  
(x1) 5/8" x 1-3/8" x 20-3/8" (16 x 34 x 517)

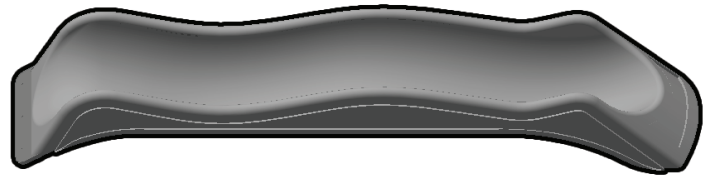

**A100287** | SLIDE VF 10FT  
(x1) A100287

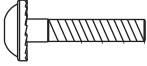

**H100397** | BOLT WH BLK  
(x3) 1/4 x 1-1/4 - H100397



**H100088** | SCREW PFH  
(x4) 8 x 1-1/8 - H100088



**H100398** | T-NUT BLK  
(x3) 1/4 - H100398

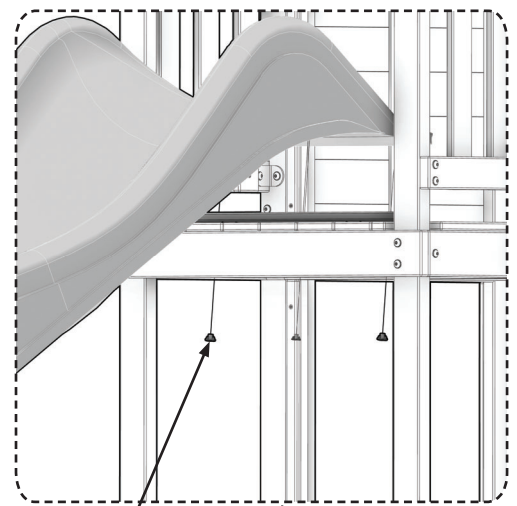
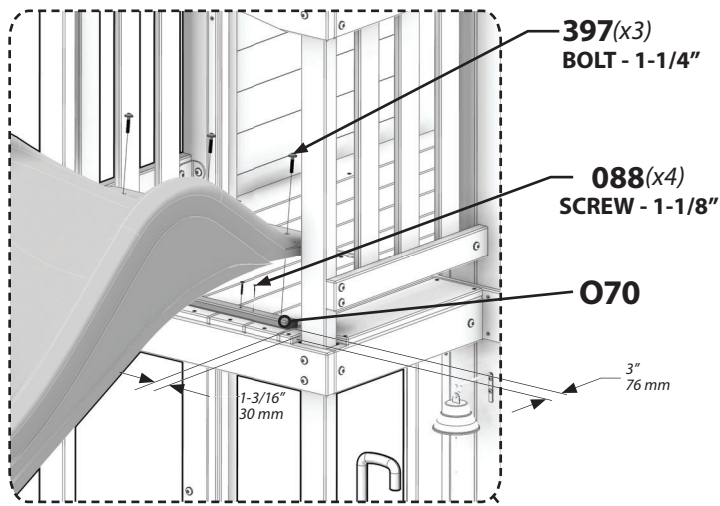

### ASSEMBLY NOTE:

USE HOLES IN SLIDE AS GUIDE FOR A 3/8" DRILL BIT FOR BOLT AND T-NUT.

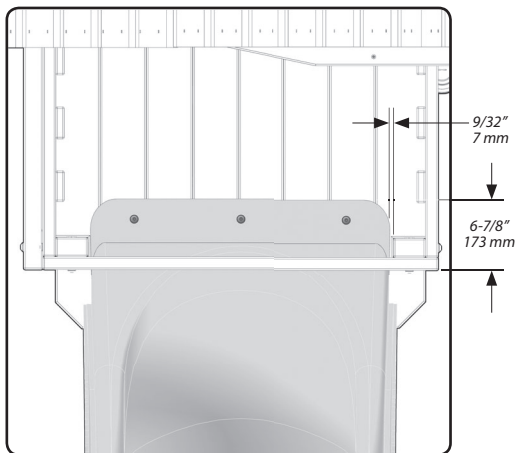

**SLIDE LOCATION**

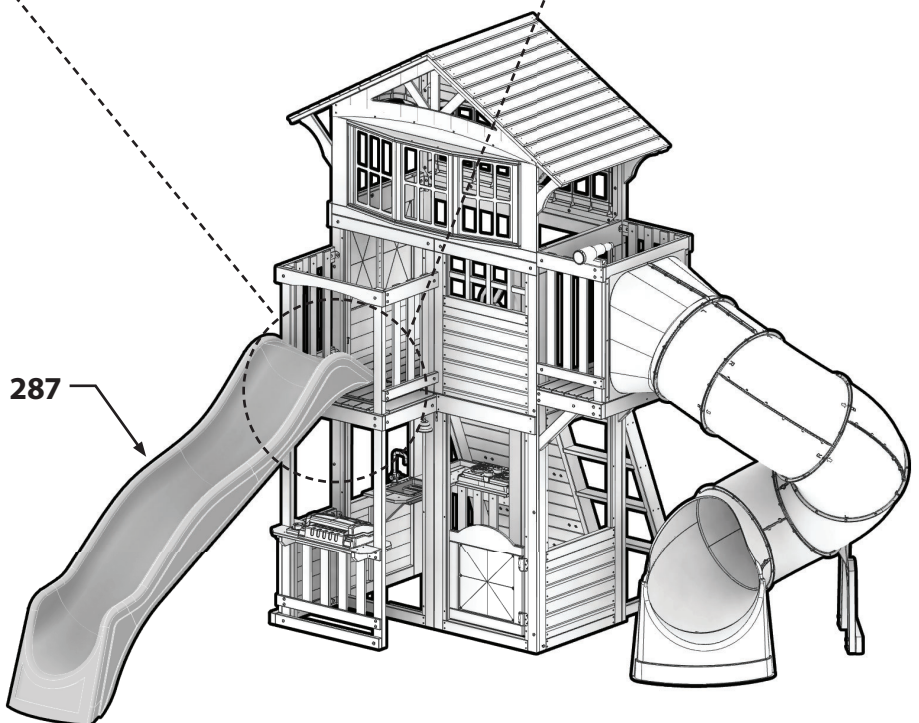



# Phase 9

## STEP 1

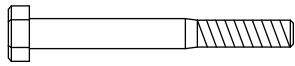

**H100658** | BOLT HEX BLK  
(x4) | 5/16x2-1/4 - H100658



**H100477** | WASHER SPLIT BLK  
(x4) | 5/16 - H100477

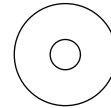

**H100478** | WASHER FLAT BLK  
(x4) | 8x27 - H100478

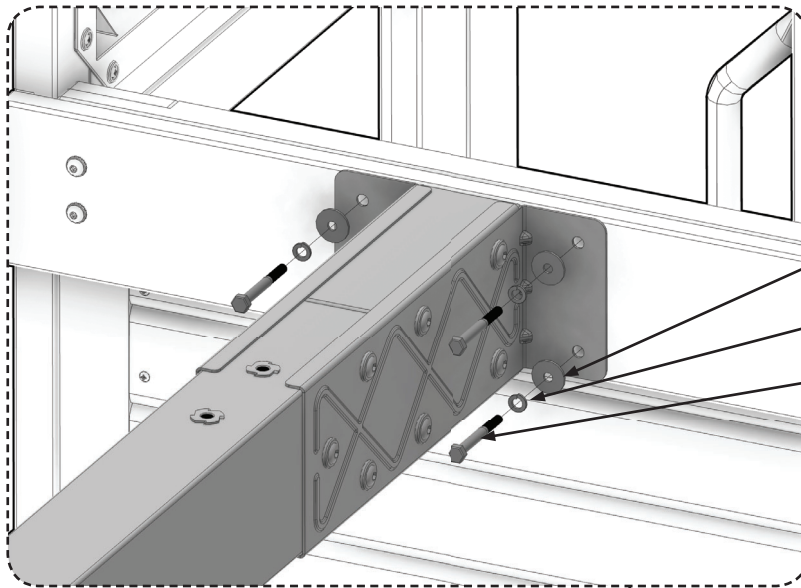

- 478(x4)  
WASHER 8x27
- 477(x4)  
WASHER SPLIT 5/16
- 658(x4)  
BOLT - 2-2/4

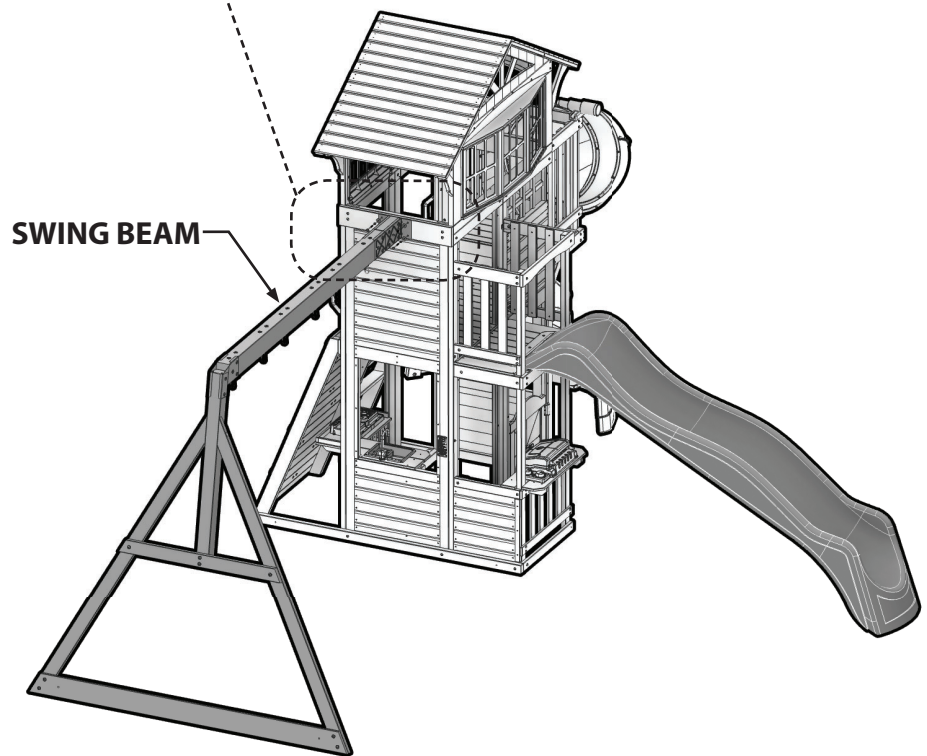



# Phase 9

## STEP 2



**A100069** | QUICK LINK  
*(x6)* | A100069

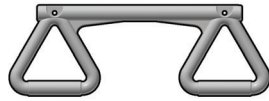

**A6P00034** | TRAPEZE  
*(x1)* | A6P00034



**A6P00054** | SWING SEAT GREEN 22"  
*(x2)* | A6P00054



**A100164** | BYD ID TAG  
*(x1)* | A100164



**A100177** | CHAIN GREEN 31"  
*(x2)* | A100177



**A100047** | CHAIN GREEN 57"  
*(x4)* | A100047



**H100202** | SCREW PWH BLK  
*(x4)* | 8x5/8 - H100202

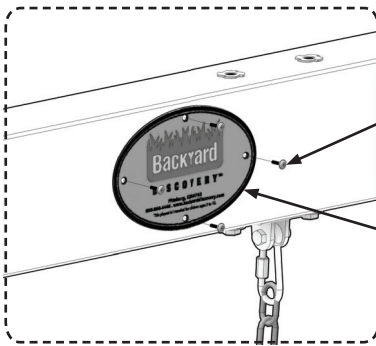

**202(x4)**  
**SCREW 5/8**

**164**

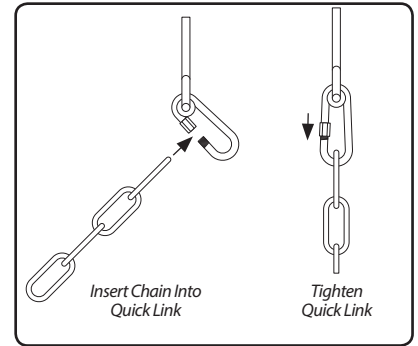

Insert Chain Into Quick Link

Tighten Quick Link

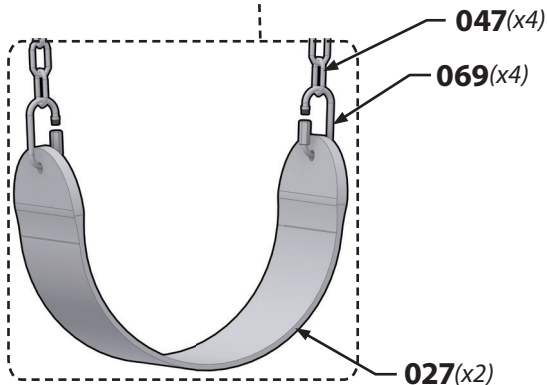
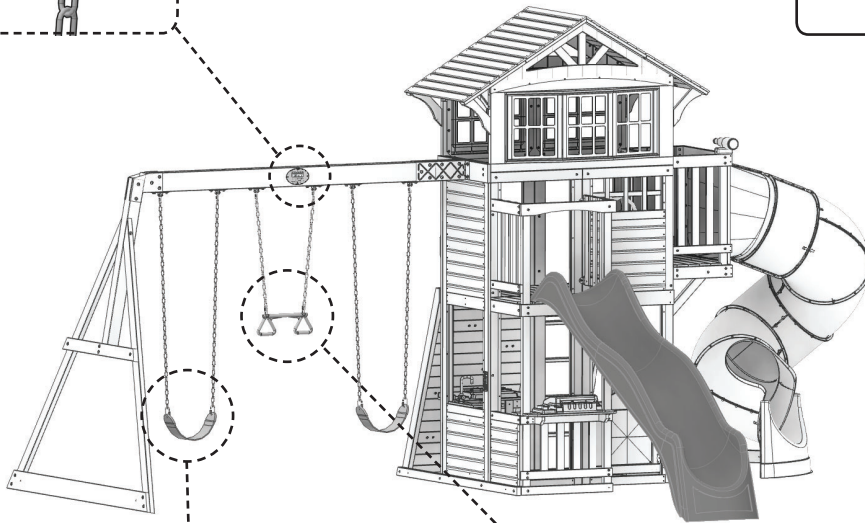

**047(x4)**

**069(x4)**

**027(x2)**

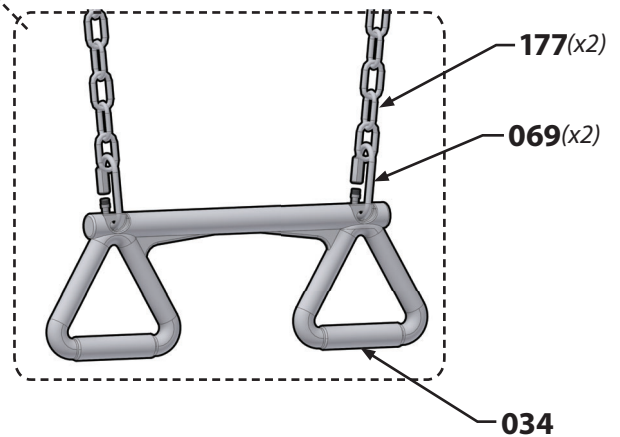

**177(x2)**

**069(x2)**

**034**



# Phase 10

## STEP 1

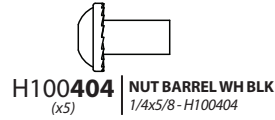
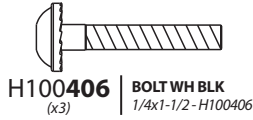
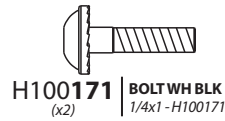
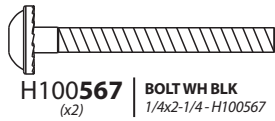
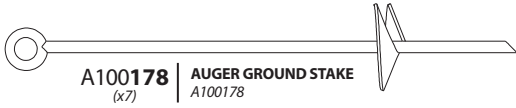

**WARNING**  
FAILURE TO USE GROUND STAKES CAN VOID WARRANTY & CAUSE INJURY!

