

Ⓔ 38mm SP-400 SCREW FINISH
"M" STYLE THREAD
WITH 1-1/2 TURNS

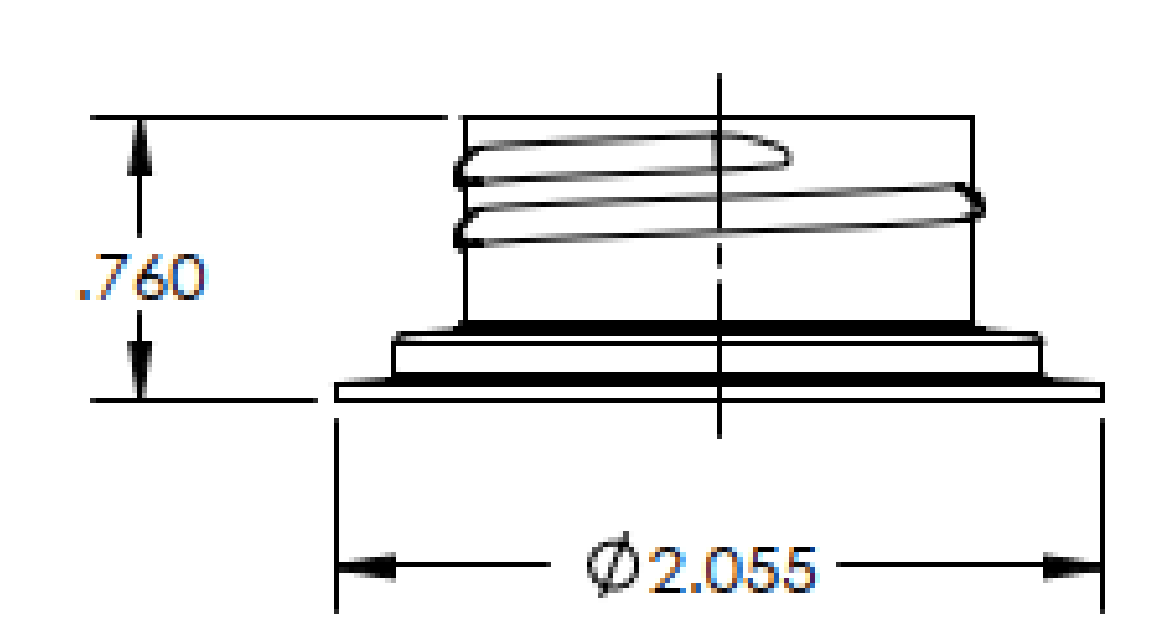

Ⓕ 38mm SP-400 SCREW FINISH
"M" STYLE THREAD
WITH 1-1/2 TURNS

BcYg
%&7 cbtU]bYfK Y[\h!! %0!%&\$ [fUa g
&EA UHYfU"!! <8D9
'E Cj YfZck '7 UdUW]mk]h '5 HYfbUHY' 6c]tca '!!%' ('" 'cn'
"Cj YfZck '7 UdUW]mk]h 'GUbXUfX' 6c]tca '!!%' +'" 'cn'
(E:]'7 UdUW]m!! %&,"\$ 'cn'
)E]t YfUbwW]g] b YggGd YWZ]YX.
"J Yf]WU"!! "\$, \$"
"c]f]hcbtU"!! "\$, \$"
"J c]a Yf]WU"!! %) '\$ 'cn'
*E 6c]hYg]c VY '7 YWYX '5 [YX 'k]h '('7 'K UHYf
+E 9]h]a UHYX '6i [Y'!! &") '\$ 'cn'

DISCLAIMER

THIS INFORMATION IS PROVIDED AS A GENERAL GUIDE, INCLUDING DIMENSIONS. IT IS THE CUSTOMER'S RESPONSIBILITIES TO SELECT THE PROPER CONTAINER FOR PRODUCT AND APPLICATION COMPATIBILITY.

DISTRIBUTED BY:



REF NO.:

DWG30774

DESCRIPTION:

128 oz HDPE Industrial Square, 38-400, 120 Gram