





HEKMAN

ASSEMBLY INSTRUCTIONS

24353-Bookcase

ⓘ A HOWARD MILLER COMPANY

HARDWARE LIST				
NO.	DESCRIPTION	SKETCH	DIMENSION	Q'TY
1		ALLEN WRENCH	5MMxL75mm	1 pc
2		SPRING WASHER	Ø5/16"	24 pcs
3		FLAT WASHER	Ø5/16"(19mm)	24 pcs
4		BOLT	Ø5/16"x 37mm	10 pcs
5		BOLT	Ø5/16"x 19mm	14 pcs

STEP 1 Lay table top face down on a soft clean surface.

STEP 2 Assemble metal Legs With Bolts #5, Lock washer #2, and Flat washer #3, Do not fully tighten Bolts at this time

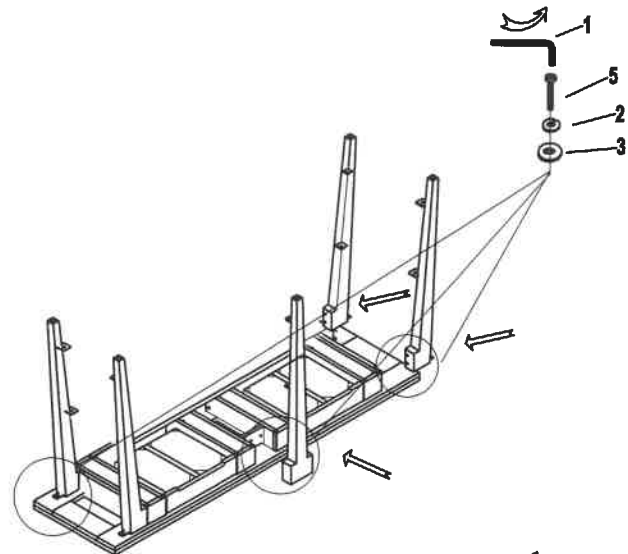

STEP 3 Assembly shelves with Bolts #4, Lock washer #2, and Flat washer #3

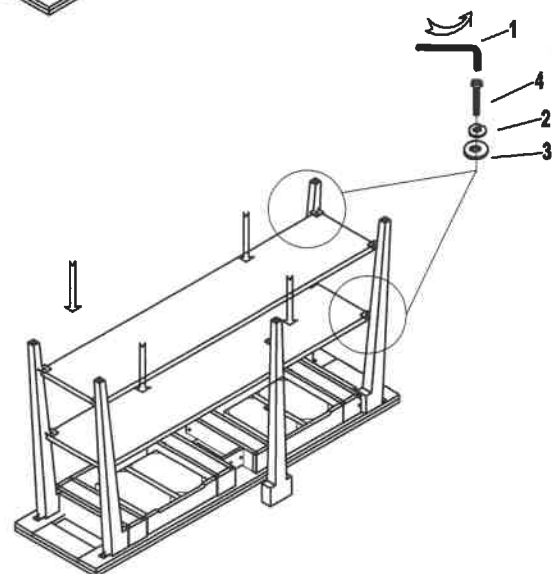

MADE IN VIETNAM

HEKMAN

ASSEMBLY INSTRUCTIONS

24353-Bookcase

STEP 4 Using Bolt #4, Lock washer #2, and Flat Washer #3 to attach Legs to the Top

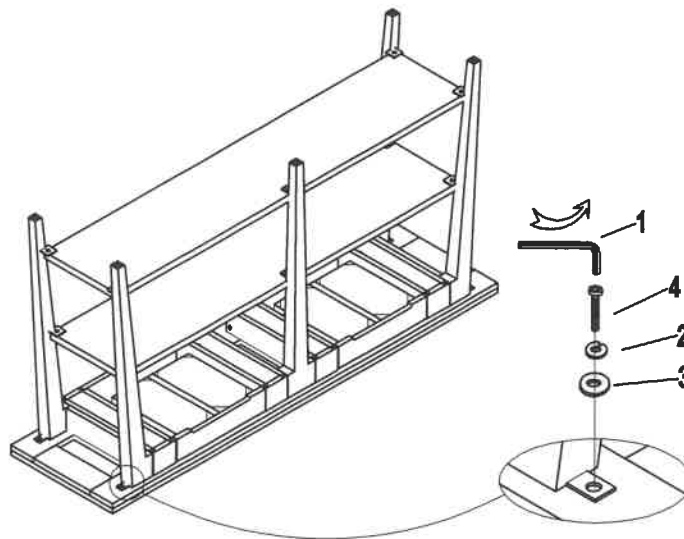

STEP 5 Tighten all Bolts with Allen Wrench #1

STEP 6 Turn table upright



MADE IN VIETNAM