



Manufactured by:
Backyard Discovery
3305 Airport Drive, Pittsburg, KS 66762
800-856-4445

Basepoint Business Centre: Rivermead Drive, Westlea, Swindon SN5 7EX Phone: 0800-118-2476
J.P. Coenstraat 7, The Bridge, The Hague, 2595 WP, Netherlands Phone: 08005678990

LANCASTER 16x14 GAZEBO

MODEL #: 2506114



WARNING

Cancer and Reproductive Harm
www.P65Warnings.ca.gov

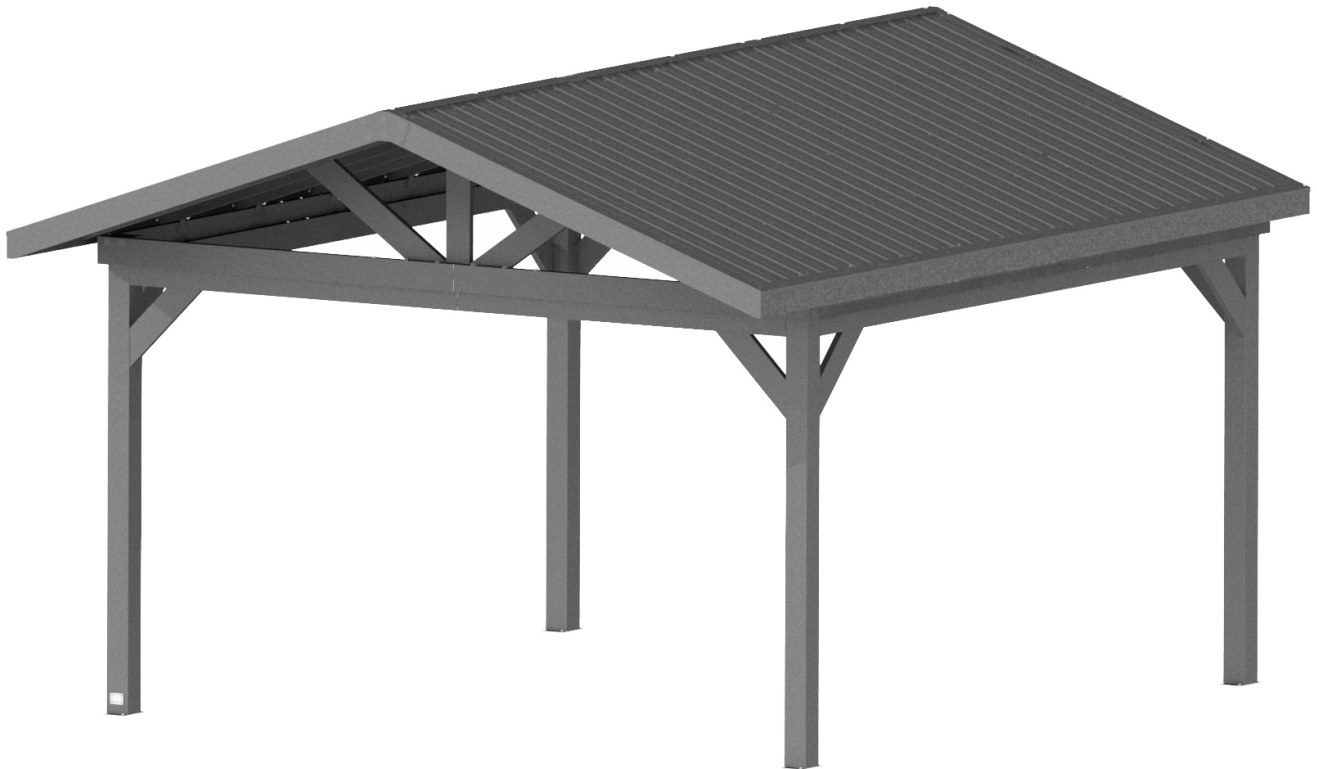

Please visit www.backyarddiscovery.com
For the most up to date assembly manual, to register your product, or to order
replacement parts Para obtener instrucciones en español, visite
www.backyarddiscovery.com



EASY STEP-BY-STEP
3D INTERACTIVE INSTRUCTIONS
DOWNLOAD THE FREE APP



OWNER'S MANUAL - BASIC SETUP DIMENSIONS & ASSEMBLY NOTES

It is critically important that you start with square and level footings or concrete pad to attach your structure.

- Pay close attention to the items needed for each step. Make sure you are using the correct hardware for each step. Using incorrect hardware may result in improper assembly
- Remember to double check for underground utilities and overhead electrical lines

Post mounts are provided with your structure which allows you to permanently install your structure to a pre-existing or new wood or concrete surface. See Anchor Instructions for further details and recommendations.

- The hardware to attach the post mounts to the structure is included.
- The hardware to mount the structure permanently to a concrete surface is included.
- The hardware to mount the structure permanently to a wood deck is NOT included and will need to be purchased separately. You must ensure there is ample structural support under the deck before permanently attaching.

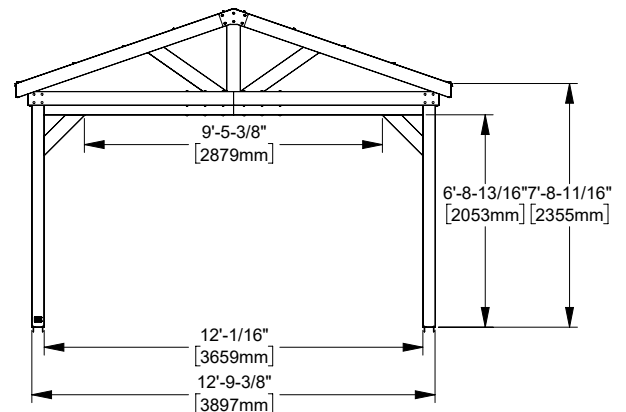
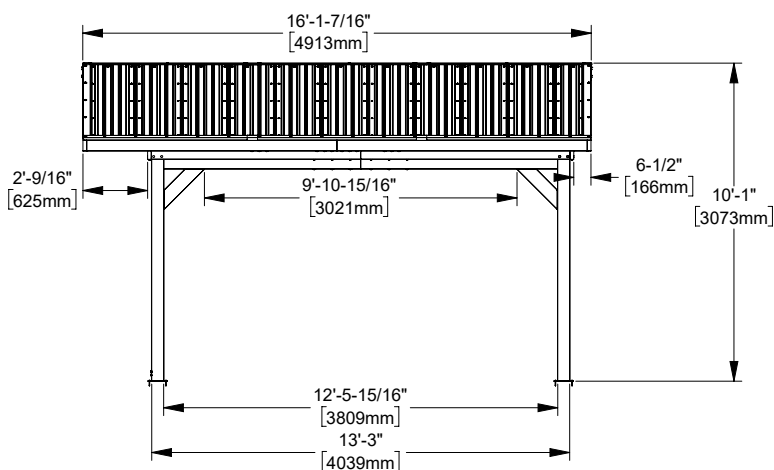
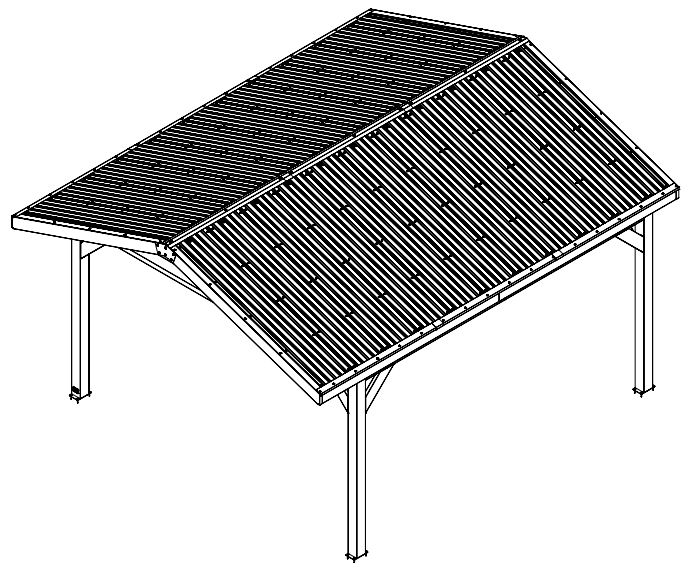
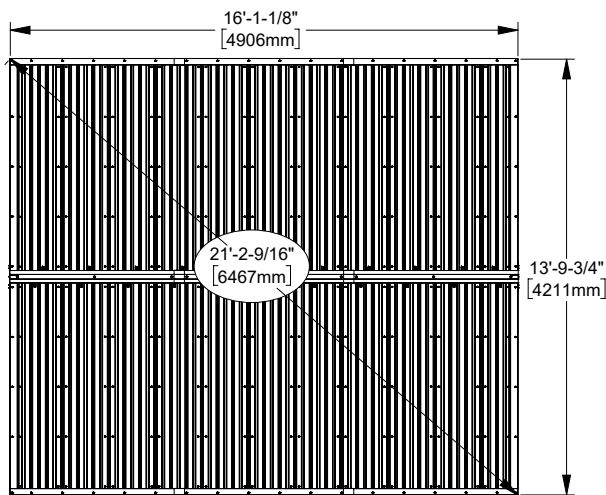

OWNER'S MANUAL - ANCHORING LAYOUT

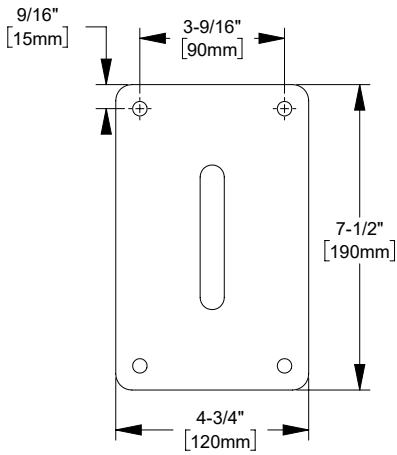
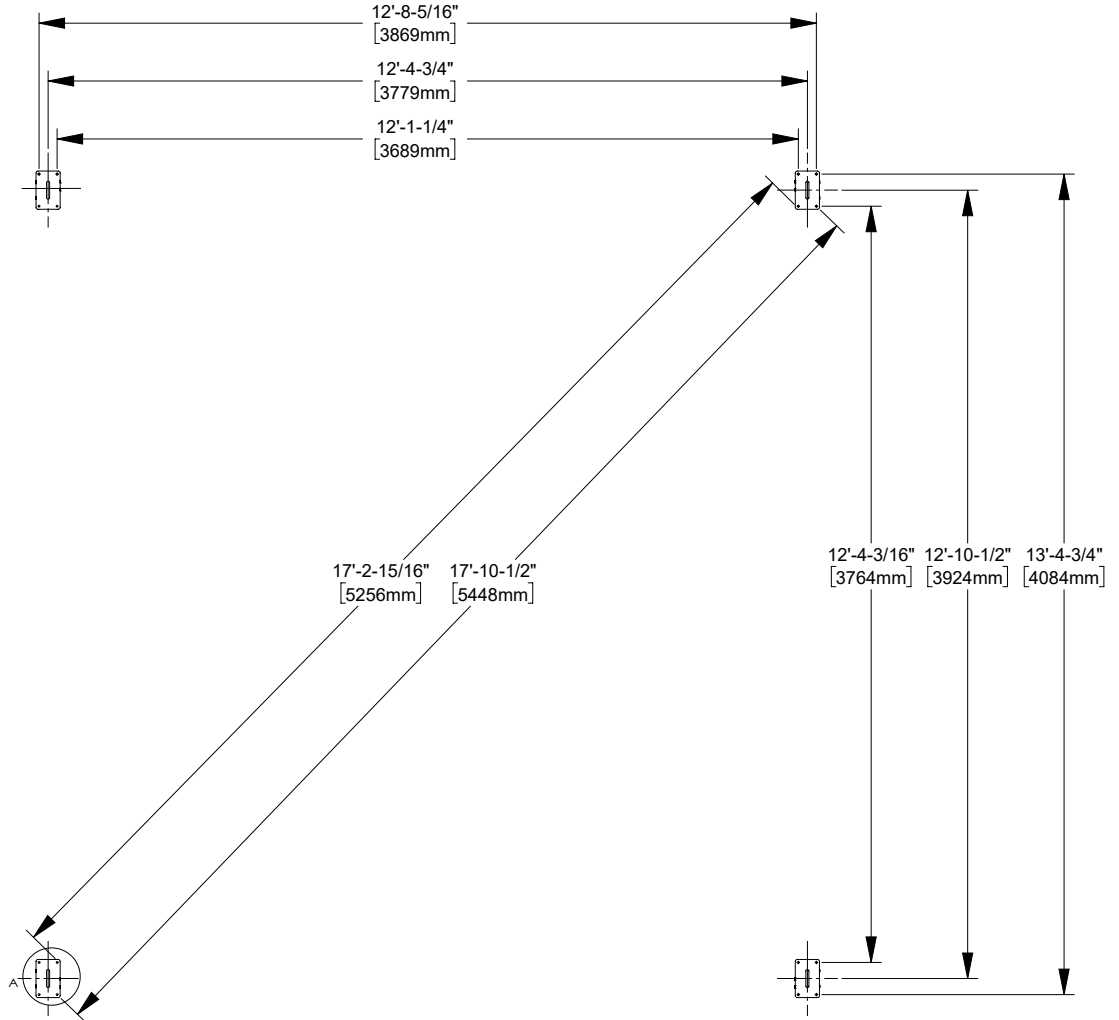

NOTE: DIMENSIONS ARE TO ANCHOR PLATES MOUNTED TO POSTS EXCEPT WHERE NOTED.

OWNER'S MANUAL - PARTS IDENTIFICATION

METAL COMPONENTS (NOT TO SCALE)

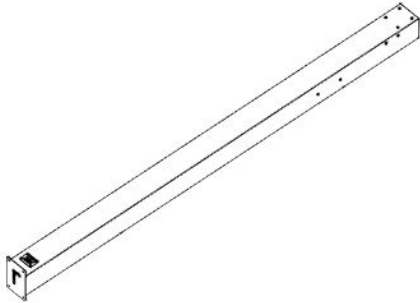

P01 FRONT POST - A4M04409
(x1) 4 3/4"x7 1/2"x89 9/16" (120x190x2275)

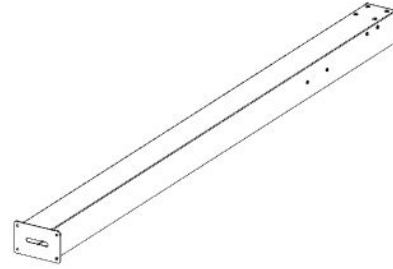

P02 POST ASSEMBLY - A4M04410
(x2) 4 3/4"x7 1/2"x89 9/16" (120x190x2275)

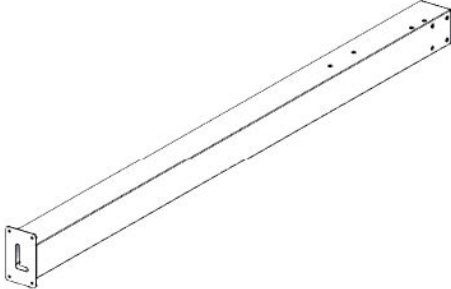

P04 POST ASSEMBLY - A4M04412
(x1) 4 3/4"x7 1/2"x89 9/16" (120x190x2275)



B01 SIDE BEAM ASSEMBLY - A4M04415
(x2) 79 11/16"x5 1/4"x1 7/16" (36x134x2023.90)



B02 SIDE BEAM ASSEMBLY - A4M04413
(x2) 74 7/8"x5 1/4"x1 7/16" (36x134x1901.40)



B03 FRONT BEAM ASSEMBLY - A4M03509
(x2) 78 3/16"x5 1/4"x1 7/16" (36x134x1986)



B04 FRONT BEAM ASSEMBLY - A4M03510
(x2) 78 3/16"x5 1/4"x1 7/16" (36x134x1986)



B05 FRONT BEAM ASSEMBLY - A4M03511
(x2) 72"x5 1/4"x1 7/16" (36x134x1829)



B06 FRONT BEAM ASSEMBLY - A4M03512
(x2) 72"x5 1/4"x1 7/16" (36x134x1829)



B07 GABLE ARM ASSEMBLY - A4M03513
(x2) 29 3/16"x5 1/4"x1 7/16" (36x134x741)

OWNER'S MANUAL - PARTS IDENTIFICATION

METAL COMPONENTS (NOT TO SCALE)



B08 GABLE ARM ASSEMBLY - A4M03514
(x2) 40 1/16"x5 1/4"x1 7/16" (36x134x1017)

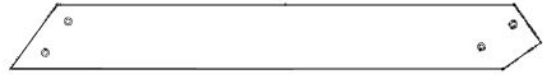

B09 GABLE ARM ASSEMBLY - A4M03515
(x2) 40 1/16"x5 1/4"x1 7/16" (36x134x1017)



B10 RIDGE BEAM ASSEMBLY - A4M04417
(x1) 100 15/16"x5 1/4"x1 7/16" (36x134x2564.28)



B11 RIDGE BEAM ASSEMBLY - A4M04418
(x1) 92 1/4"x5 1/4"x1 7/16" (36x134x2343.50)

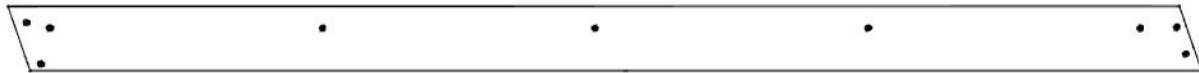

B12 GABLE BEAM ASSEMBLY - A4M03518
(x2) 88 13/16"x5 1/4"x1 7/16" (36x134x2255)



B13 GABLE BEAM ASSEMBLY - A4M03519
(x2) 88 13/16"x5 1/4"x1 7/16" (36x134x2255)



B14 DRIP BEAM ASSEMBLY - A4M04420
(x2) 95 3/16"x4 13/16"x1 7/16" (36x122x2417.75)



B15 DRIP BEAM ASSEMBLY - A4M04421
(x2) 95 3/16"x4 13/16"x1 7/16" (36x122x2417.75)



B16 SIDE BEAM ASSEMBLY - A4M04414
(x2) 74 7/8"x5 1/4"x1 7/16" (36x134x1901.40)



B17 SIDE BEAM ASSEMBLY - A4M04416
(x2) 79 11/16"x5 1/4"x1 7/16" (36x134x2023.90)



R01 RAFTER ASSEMBLY - A4M03522
(x2) 86 3/8"x4 5/16"x3 1/8" (80x110x2194.6)



R02 RAFTER ASSEMBLY - A4M03523
(x2) 86 3/8"x4 5/16"x3 1/8" (80x110x2194.6)



R03 RAFTER ASSEMBLY - A4M03524
(x10) 86 3/8"x4 5/16"x3 1/8" (80x110x2194.6)

OWNER'S MANUAL - PARTS IDENTIFICATION

METAL COMPONENTS (NOT TO SCALE)



E01 PURLIN ASSEMBLY - A4M04423
(x10) 104 1/16"x1 9/16"x13/16" (40x50x2645.40)



E02 PURLIN ASSEMBLY - A4M04424
(x10) 86 1/16"x1 15/16"x1 9/16" (40x50x2185.40)



C01 CORBEL ASSEMBLY - A4M03525
(x4) 21 13/16"x5 1/4"x2 3/4" (70x134x553.5)



C02 CORBEL ASSEMBLY - A4M03526
(x4) 21 13/16"x5 1/4"x2 3/4" (70x134x553.5)

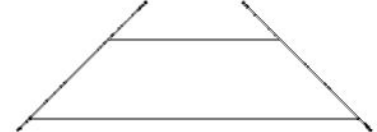

C03 CORBEL ASSEMBLY - A4M03527
(x2) 23 3/8"x12"x1 7/16" (36x304x593)



J1 SPLICE BRACKET - A4M02230
(x8) 1 5/16"x5 3/16"x39 3/8" (33.2x131.2x1000)



J2 SPLICE BRACKET - A4M01270
(x1) 1 1/4"x5 1/8"x15 3/4" (33x131x400)

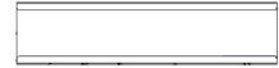

J6 SPLICE BRACKET - A4M03806
(x2) 19 11/16"x4 11/16"x32.5 (32.5x118.5x500)



A4M04426 STEEL SHEETING
(x2)



A4M03528 STEEL SHEETING
(x20)

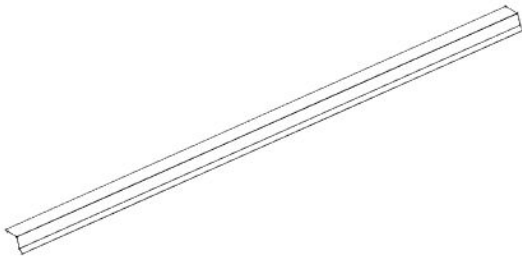

A4M04427 DRIP TRIM
(x6)

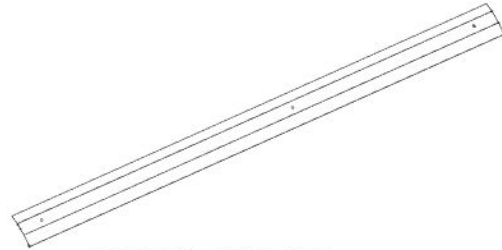

A4M04428 RIDGE CAP
(x1)

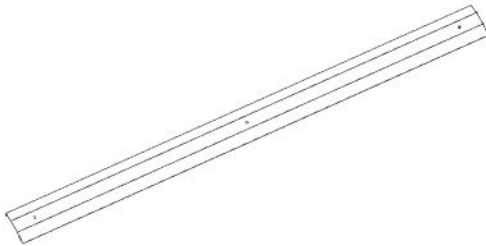

A4M04429 RIDGE CAP
(x2)

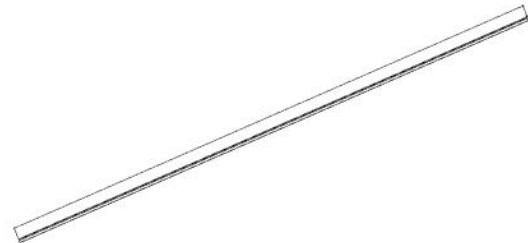

A4M03532 EDGE TRIM
(x4)



A4M03535 RIDGE CAP SPLICE
(x2)



A4M05365 DRIP TRIM SPLICE
(x4)

OWNER'S MANUAL - PARTS IDENTIFICATION

METAL COMPONENTS (NOT TO SCALE)

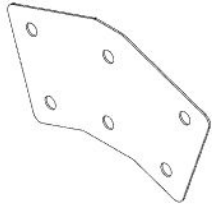

J3 GABLE BRACKET - A4M03805
(x2) 11 1/8"x6 7/16"x1/16" (2x163x282)



J4 BEAM BRACKET - A4M02990
(x8) 1"x1 5/16"x5 1/16" (25x33.2x128)

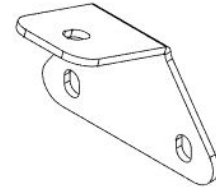

J5 RAFTER BRACKET - A4M03803
(x10) 3 5/8"x2 11/16"x2 1/16" (52x68x91.5)

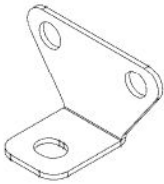

J7 RAFTER BRACKET - A4M03802
(x4) 3 5/8"x2 3/16"x2" (50x55x92)

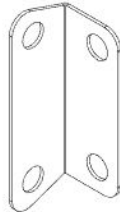

J8 GABLE BRACKET - A4M03804
(x4) 4 13/16"x1 9/16"x1 9/16" (40x40x123)

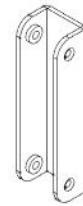

J9 BEAM BRACKET - A4M03807
(x4) 5 9/16"x1 5/16"x4 9/16" (140.57x33.20x116)



J10 SUPPORT RING - A4M03808
(x9) 13/16"x7/16" (11x20x)

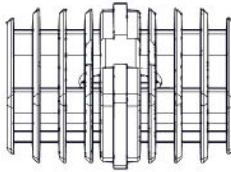

A6P00530 2-WAY SQUARE PLUG
(x10)



A4M01352 HOLE COVER
(x72)

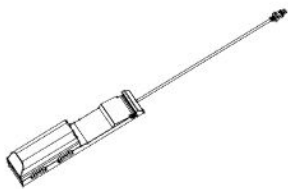

9205413 ELECTRICAL ENCLOSURE
(x1)

OWNER'S MANUAL - PARTS IDENTIFICATION

HARDWARE COMPONENTS

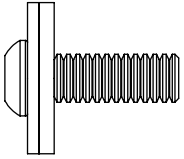

H101202 | TORX PAN HEAD
(x377) | 1/4-20x3/4 ASSY



H101293 | TORX PAN HEAD
(x9) | 1/4-20x1 3/8" BLK

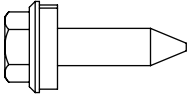

H101117 | SCREW WOODGRIP
(x225) | 10-16 x 3/4 BLK

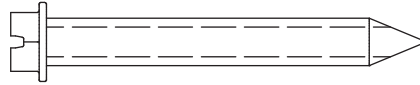

H100120 | CONCRETE ANCHOR
(x16) | 1/4"x2" BLK

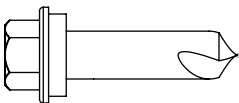

H101116 | SCREW SELF TAPPING
(x52) | 1/4x1 BLK

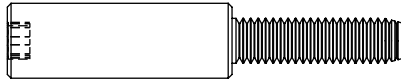

H101103 | TORX SOCKET SCREW
(x72) | 1/4-20 BLK

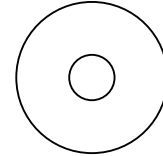

H101053 | STEEL WASHER
(x9) | 6x20 BLK

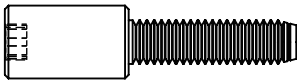

H101132 | TORX SOCKET SCREW SHORT
(x70) | 1/4-20 BLK

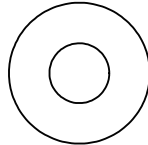

H100630 | WASHER FLAT
(x16) | 8x19 BLK

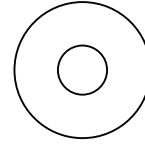

H101054 | SEALANT WASHER
(x9) | 6.5x18 BLK



H101230 | BOLT WH
(x2) | 5/16x6 S.S BLK

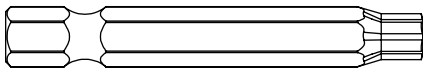

H100147 | TORX BIT
(x1) | T-30

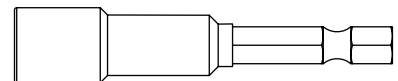

H101106 | SOCKET DRIVER
(x1) |

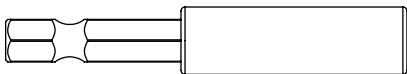

H101100 | MAGNETIC DRIVER
(x1) |

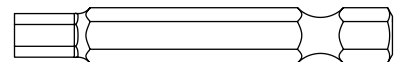

H101294 | HEX DRIVER
(x1) |

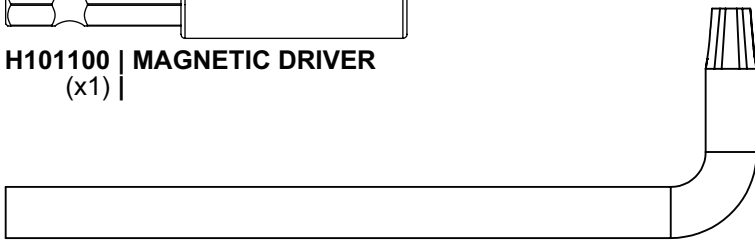

H100114 | TORX BIT
(x1) | T-30

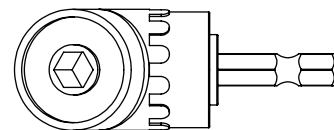

**H101114 | RIGHT ANGLE
DRILL ADAPTER**
(x1) |

PRE-ASSEMBLY STEP 1 - SORTING PARTS

It is critical for ease of assembly that you take the time to sort and organize the parts and hardware.

METAL PARTS:

- Organize metal parts by the three-digit, alpha-numeric number stamped on each part (ex. P01).
- If there are multiple parts with the same stamped number, stack those pieces together.
- Stamps can be found on the flat surface of the parts or on the end of the parts.
- Allow yourself plenty of room - the parts can take up a significant amount of space.

NOTE: CARTONS ARE NOT ORGANIZED BY PART OR STEP NUMBER.

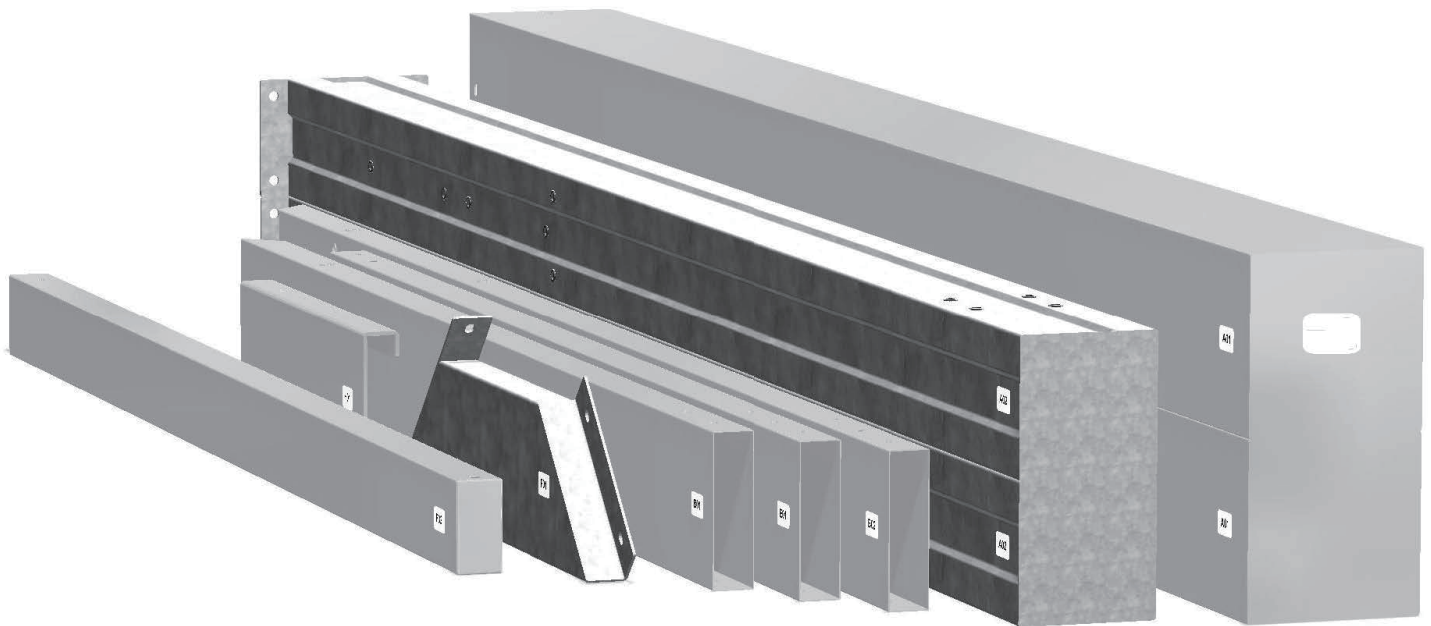

HARDWARE PARTS:

- We recommend that you have a separate table to organize the hardware.
- Hardware bags are printed with a seven-digit, alpha-numeric part number.
- You can organize your hardware by part number or group by hardware type (e.g. bolts, nuts, etc.).
- During assembly you only need to reference the last four digits of the number.

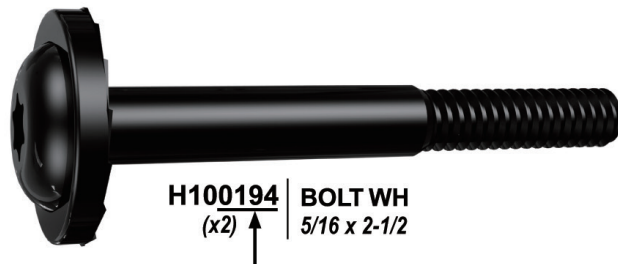

PRE-ASSEMBLY STEP 2 - TOOLS REQUIRED



Cordless Drill or
Electric Drill



Drill Attachments:
Phillips Head



1/8", 3/16", 3/8" &
7/16" Drill Bits



Phillips Screw Driver



Open End Wrench
7/16"



3/8" Drive Ratchet, 1/2" &
7/16" STD Sockets 1/2" & 7/16"
Deep Sockets



Claw Hammer

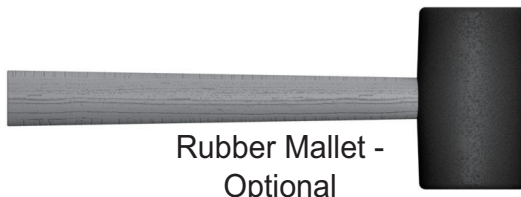

Rubber Mallet -
Optional

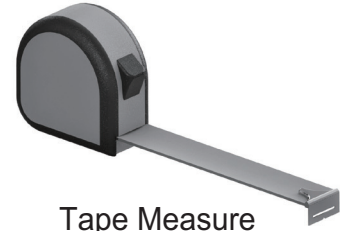

Tape Measure

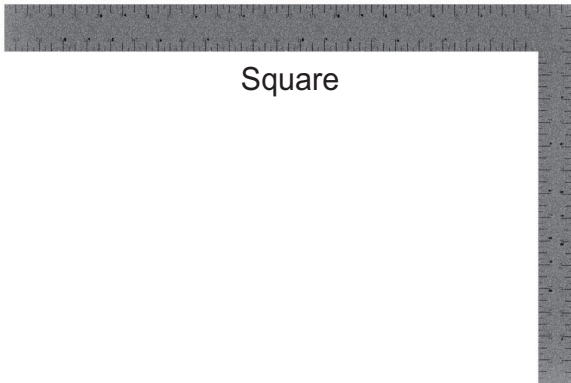

Square



Level 24"

PRE-ASSEMBLY STEP 3 - CHOOSE YOUR ASSEMBLY METHOD

There are several types of assembly instructions available to you.

1. Printed Assembly Manual included with your set
2. BILT APP - 3D interactive instructions
3. Combination of the Printed Manual and BILT APP (Note: Step numbers can differ between the two methods)

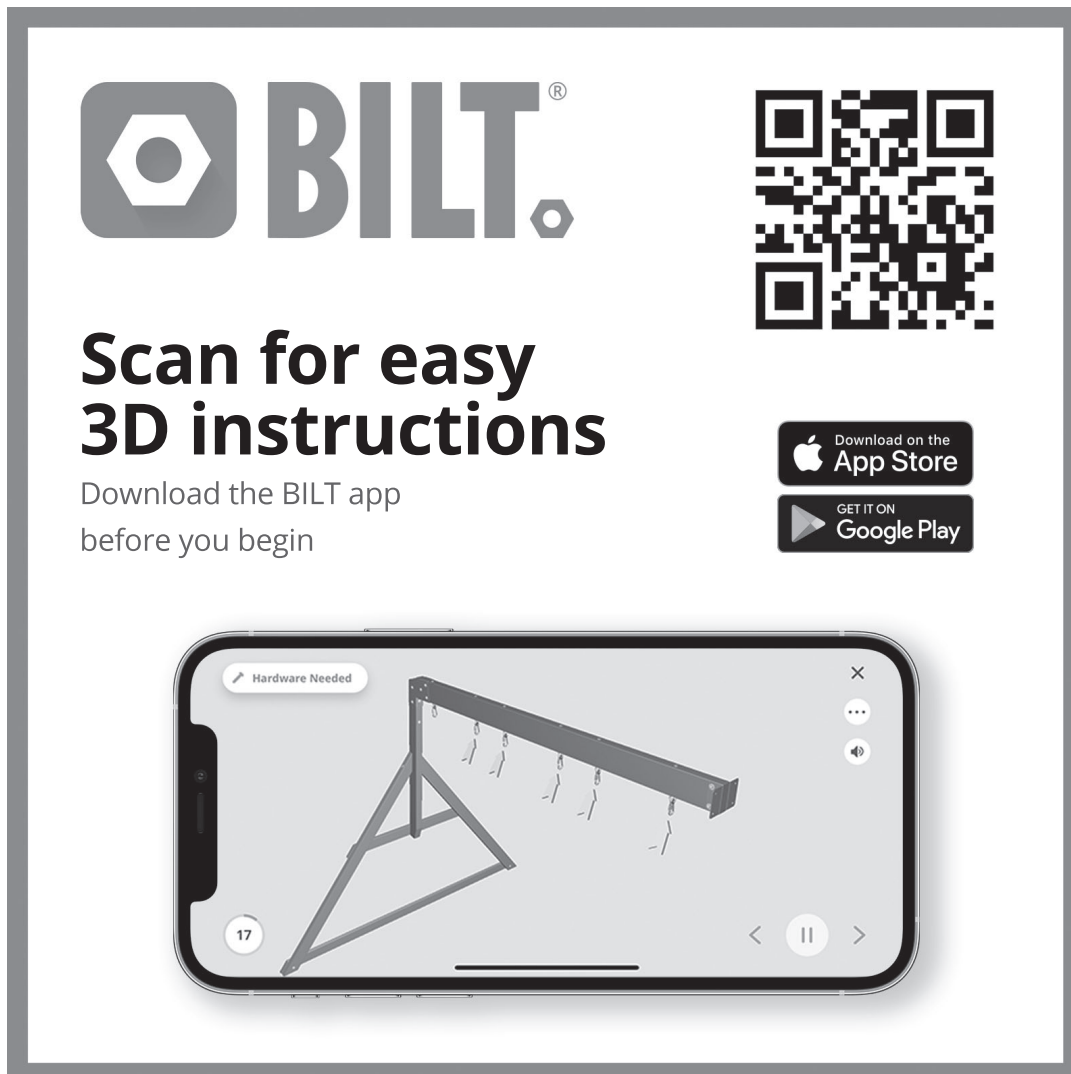

BILT.[®]

Scan for easy
3D instructions

Download the BILT app
before you begin

Download on the
App Store

GET IT ON
Google Play

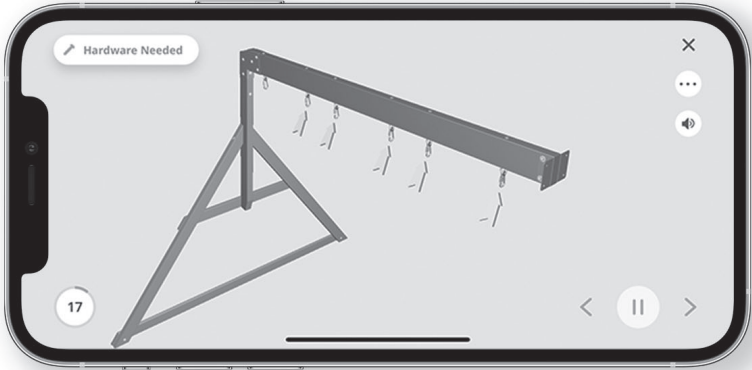

Hardware Needed

17

< || >

The image shows a promotional graphic for the BILT app. At the top left is the BILT logo, which consists of a stylized hexagonal bolt head icon followed by the word "BILT." with a registered trademark symbol. To the right of the logo is a large QR code. Below the logo and QR code, the text "Scan for easy 3D instructions" is written in a large, bold font. Underneath this, it says "Download the BILT app before you begin". To the right of this text are two buttons: "Download on the App Store" and "GET IT ON Google Play". At the bottom of the graphic is a smartphone displaying the BILT app interface. The app shows a 3D assembly diagram of a metal frame with a horizontal bar and several hanging components. The interface includes a "Hardware Needed" button at the top left, a close button (X) at the top right, a menu button (three dots) and a volume icon below it, and a page number "17" in a circle at the bottom left. At the bottom center of the screen are navigation arrows and a pause button.

STEP 1 - BEAM ASSEMBLY

Qty	PartNo	Description
6	H101202	TORX PAN HEAD 1/4-20x3/4 ASSY



B04 FRONT BEAM ASSEMBLY - A4M03510
(x1) 78 3/16"x5 1/4"x1 7/16" (36x134x1986)



J1 SPLICE BRACKET - A4M02230
(x1) 1 5/16"x5 3/16"x39 3/8" (33.2x131.2x1000)

- FOR EASE OF ASSEMBLY, WE RECOMMEND USING SAW HORSES FOR STEPS 1 - 12.

1202 (x6)
TORX PAN HEAD 1/4-20x3/4 ASSY
HAND TIGHTEN ONLY

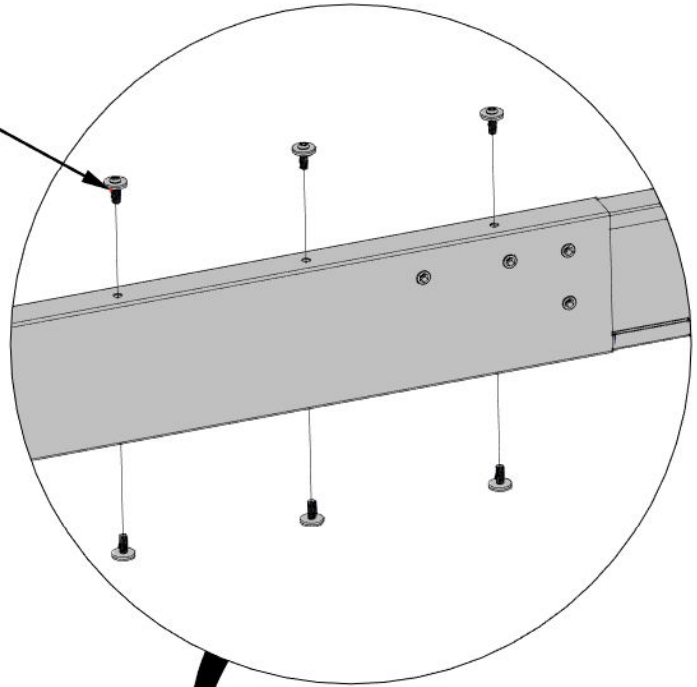

B04 (x1)
FRONT BEAM ASSEMBLY

J1 (x1)
SPLICE BRACKET

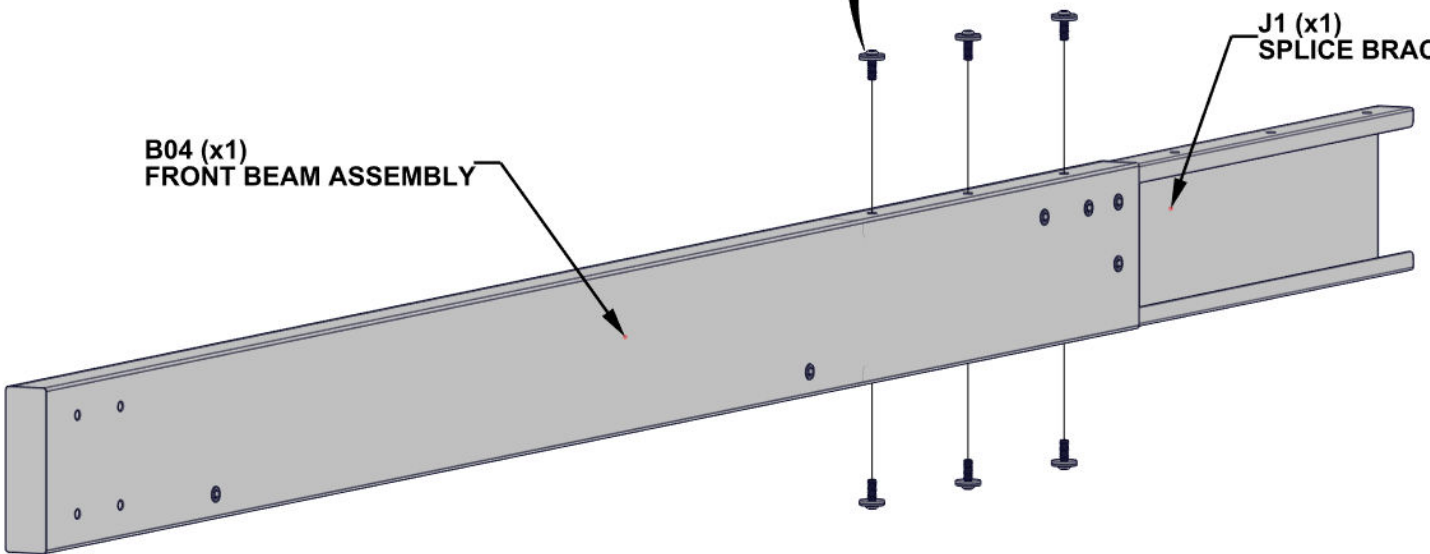

BEAM AND SPLICE MUST BE ORIENTED AS SHOWN ABOVE. SLIDE J1 INTO B04 AND LINE UP THREE HOLES TOP AND BOTTOM

STEP 2 - BEAM ASSEMBLY

Qty	PartNo	Description
6	H101202	TORX PAN HEAD 1/4-20x3/4 ASSY



B03 FRONT BEAM ASSEMBLY - A4M03509
(x1) 78 3/16"x5 1/4"x1 7/16" (36x134x1986)

- SLIDE B03 ONTO SPLICE BRACKET.
GENTLY TAP ENDS OF ASSEMBLY WITH
RUBBER Mallet UNTIL GAP CLOSES.

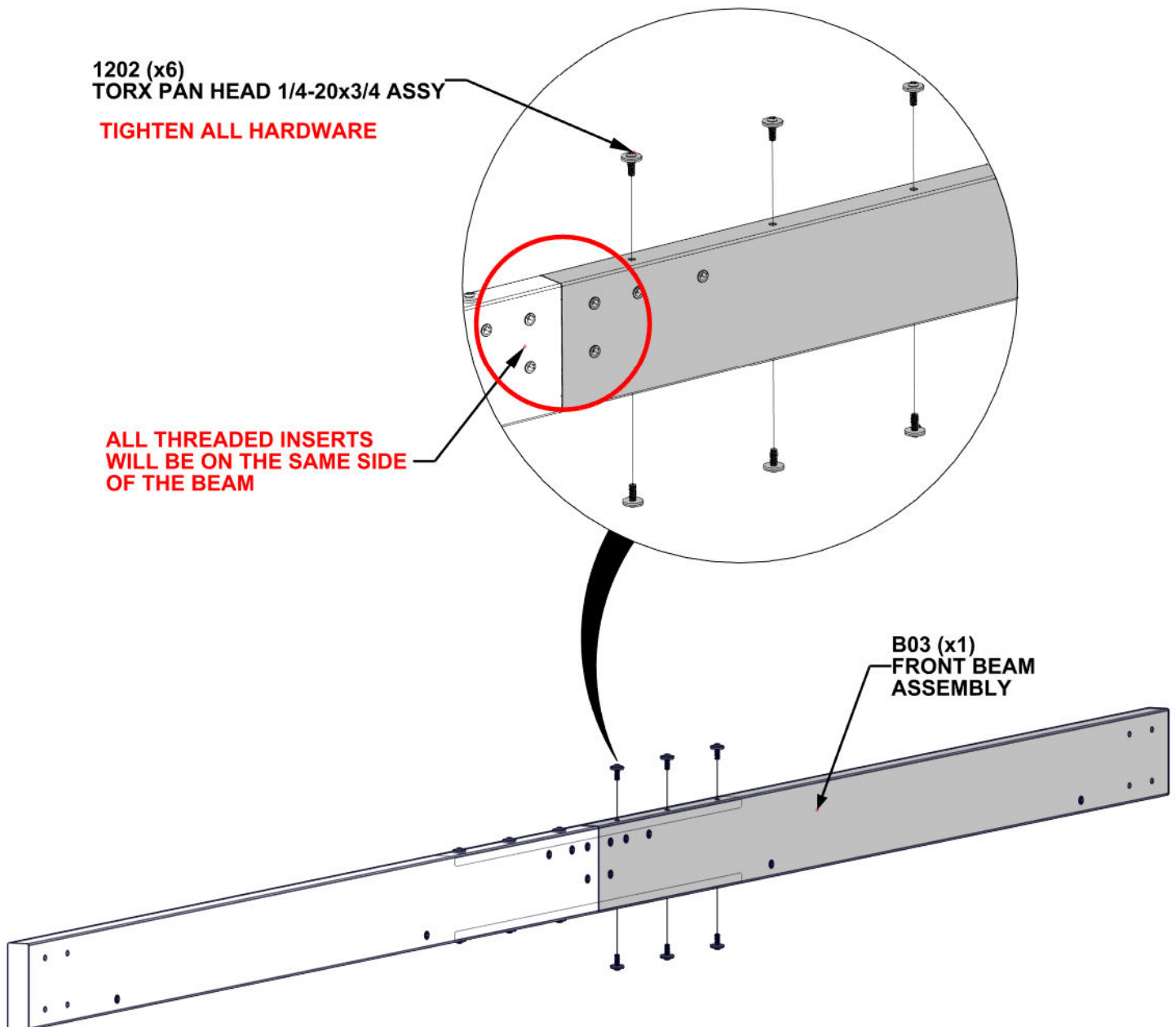

STEP 3 - BEAM ASSEMBLY

Qty	PartNo	Description
6	H101202	TORX PAN HEAD 1/4-20x3/4 ASSY



B06 FRONT BEAM ASSEMBLY - A4M03512
(x1) 72"x5 1/4"x1 7/16" (36x134x1829)



J1 SPLICE BRACKET - A4M02230
(x1) 1 5/16"x5 3/16"x39 3/8" (33.2x131.2x1000)

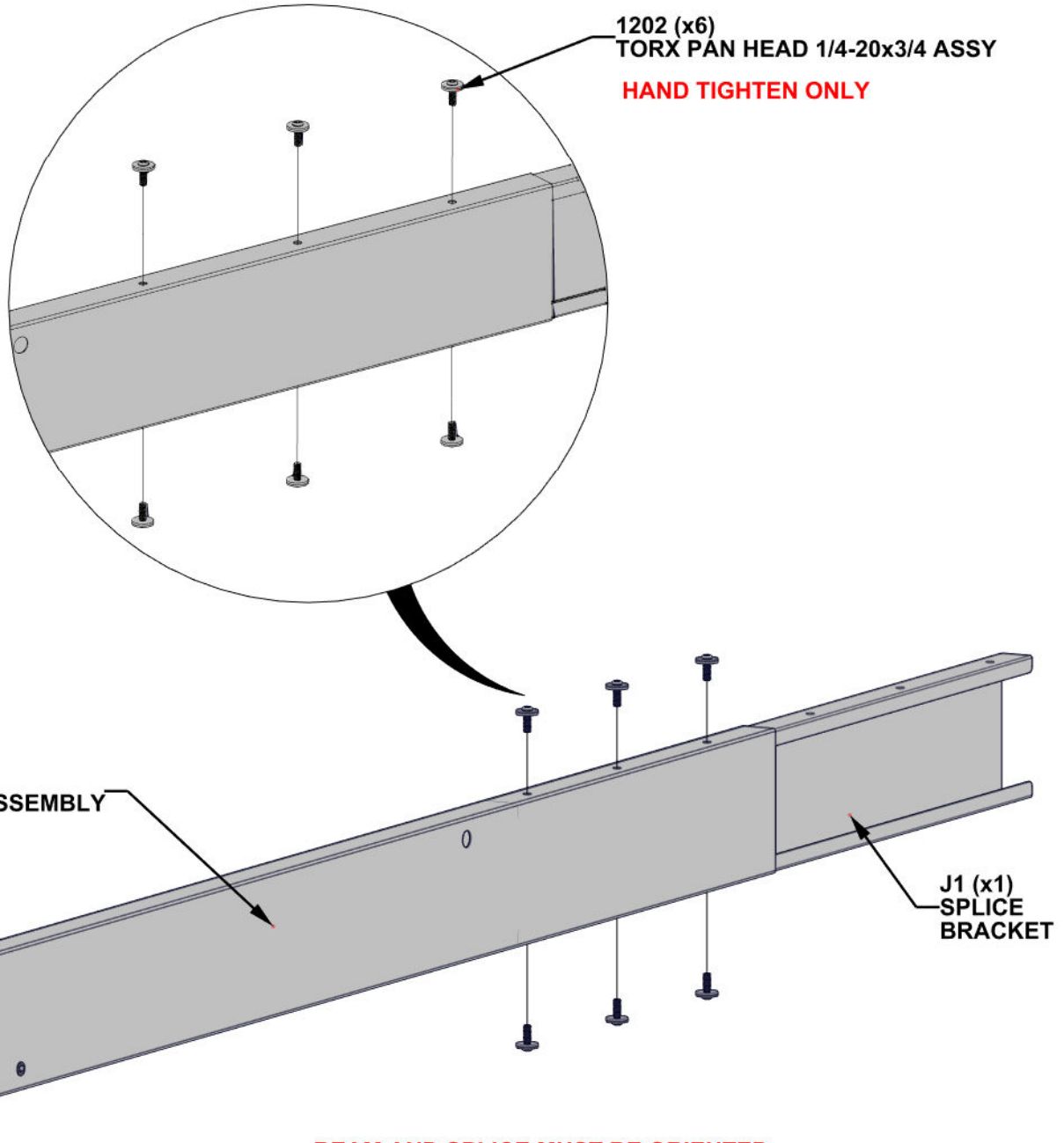

BEAM AND SPLICE MUST BE ORIENTED AS SHOWN ABOVE. SLIDE J1 INTO B06 AND LINE UP THREE HOLES TOP AND BOTTOM

STEP 4 - BEAM ASSEMBLY

Qty	PartNo	Description
6	H101202	TORX PAN HEAD 1/4-20x3/4 ASSY



B05 FRONT BEAM ASSEMBLY - A4M03511
(x1) 72"x5 1/4"x1 7/16" (36x134x1829)

- SLIDE B05 ONTO SPLICE BRACKET.
GENTLY TAP ENDS OF ASSEMBLY WITH
RUBBER Mallet UNTIL GAP CLOSES.

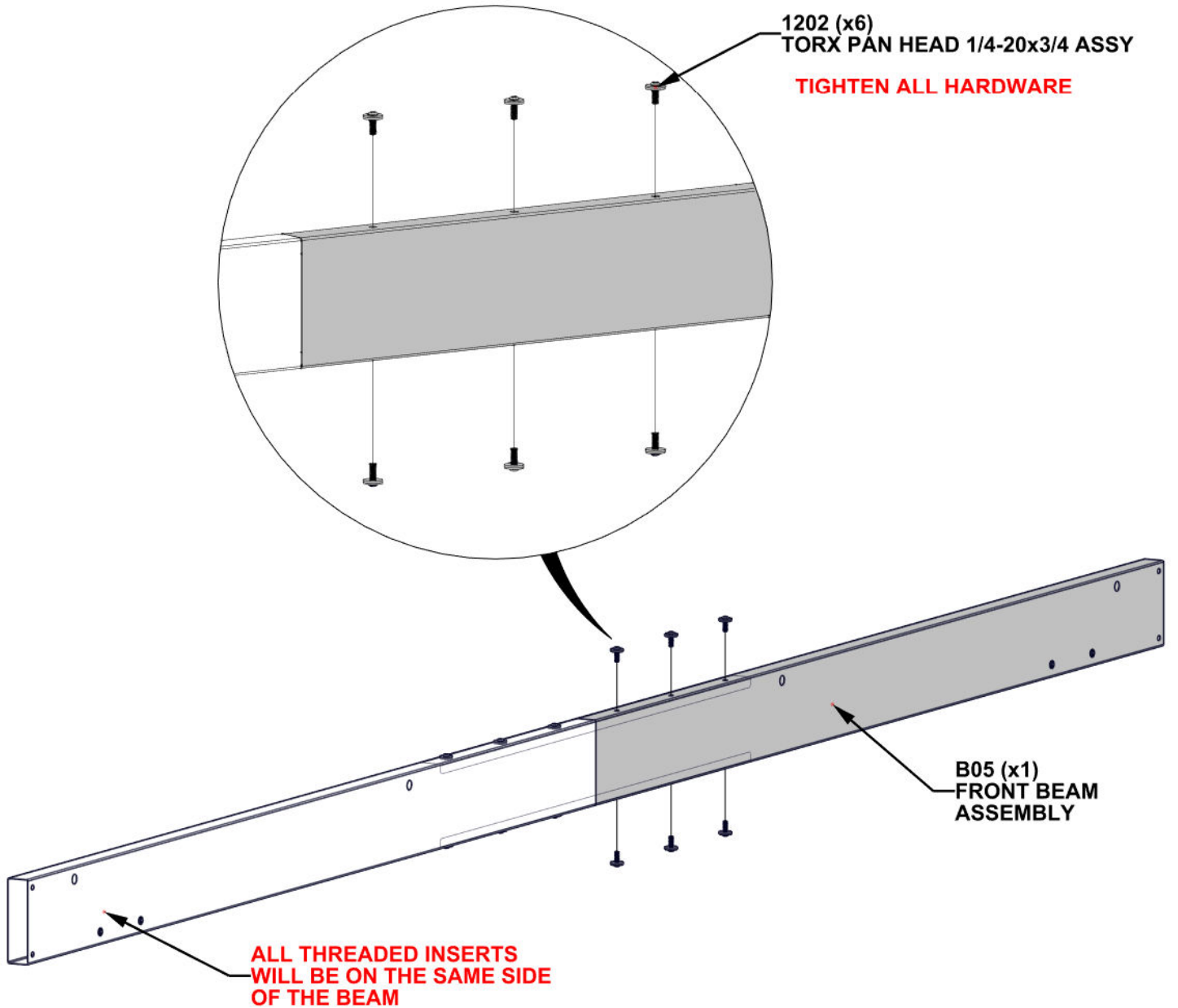

STEP 5 - BEAM ASSEMBLY

Qty	PartNo	Description
4	H101103	TORX SOCKET SCREW 1/4-20

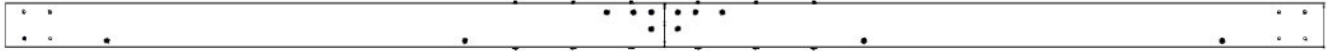

UPPER BEAM ASSEMBLY STEPS 1 - 2

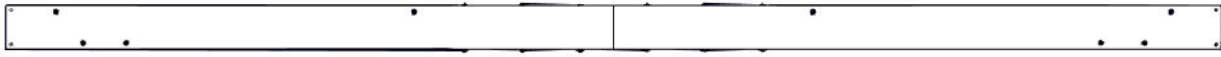

LOWER BEAM ASSEMBLY STEPS 3 - 4

- ALIGN THROUGH HOLES IN LOWER BEAM ASSEMBLY WITH THREADED INSERTS IN UPPER BEAM ASSEMBLY

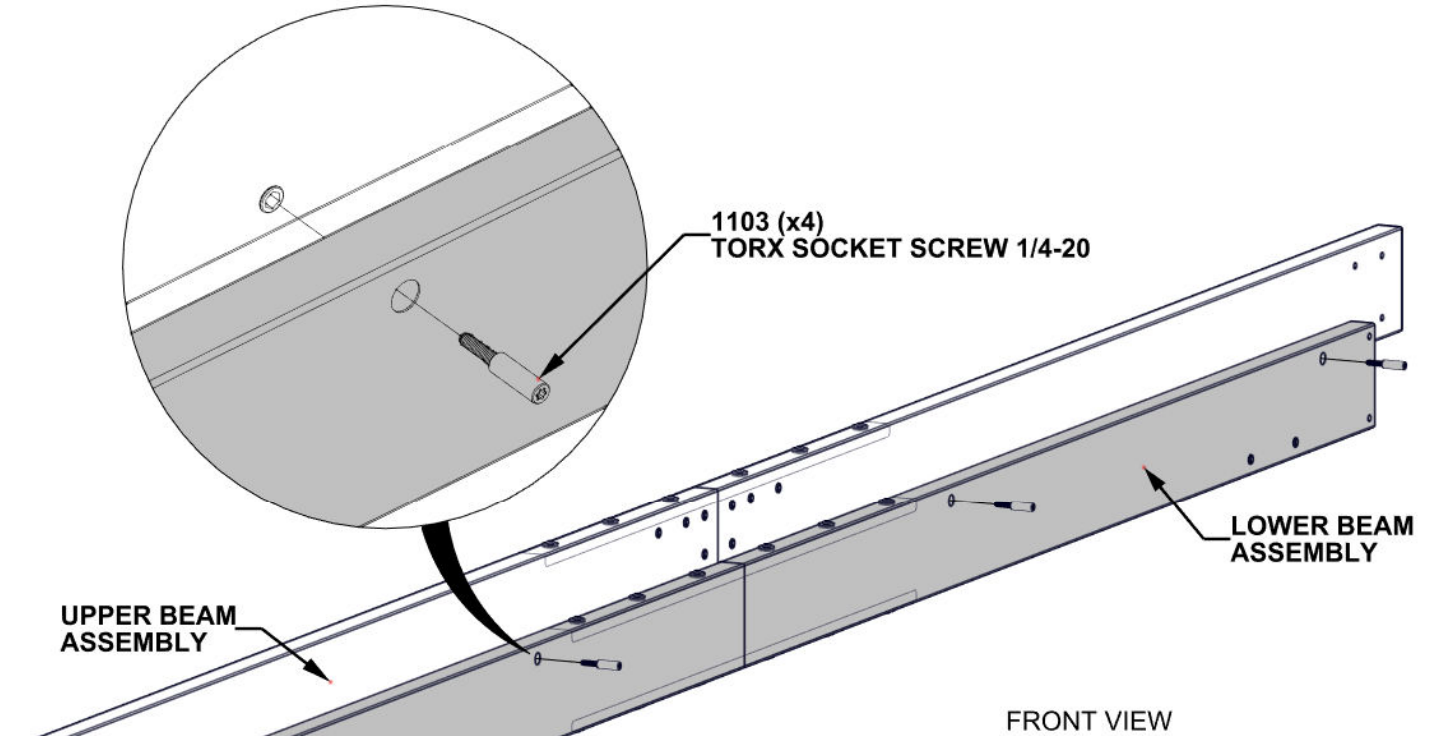

DIMENSIONS ARE THE SAME AT BOTH ENDS AND CRITICAL TO THE BEAM ASSEMBLY

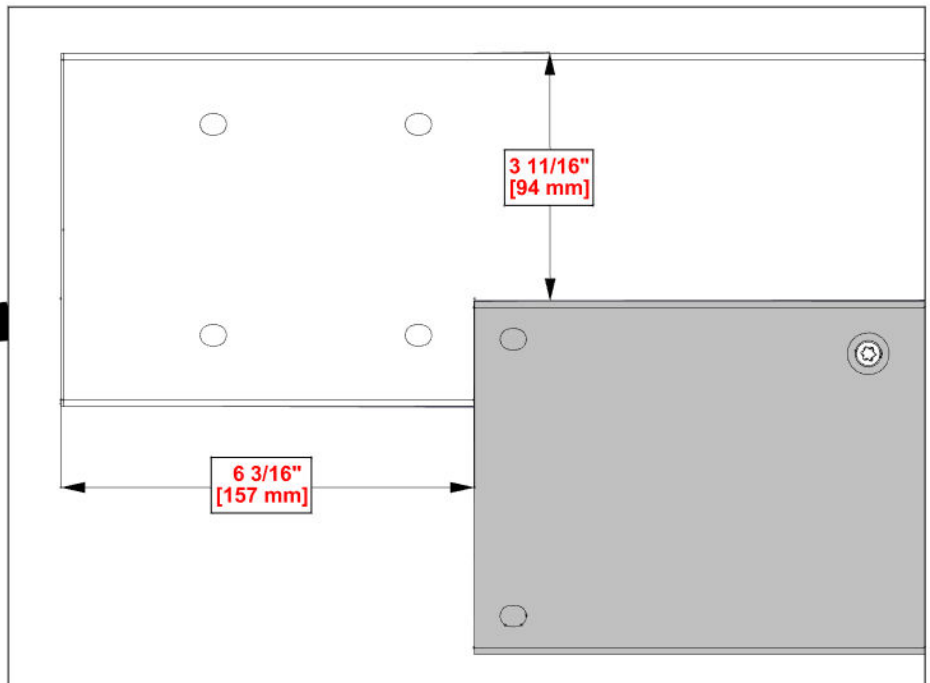

**REPEAT BEAM ASSEMBLY
STEPS 1 THROUGH 5**

STEP 6 - POST ASSEMBLY

Qty	PartNo	Description
4	H101202	TORX PAN HEAD 1/4-20x3/4 ASSY

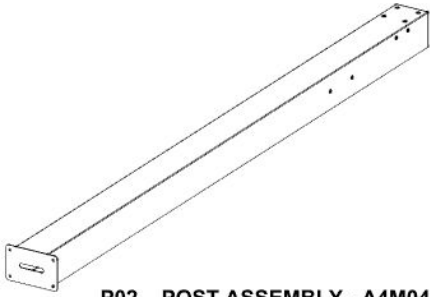

P02 POST ASSEMBLY - A4M04410
(x1) 4 3/4"x7 1/2"x89 9/16" (120x190x2275)



J4 BEAM BRACKET - A4M02990
(x2) 1"x1 5/16"x5 1/16" (25x33.2x128)

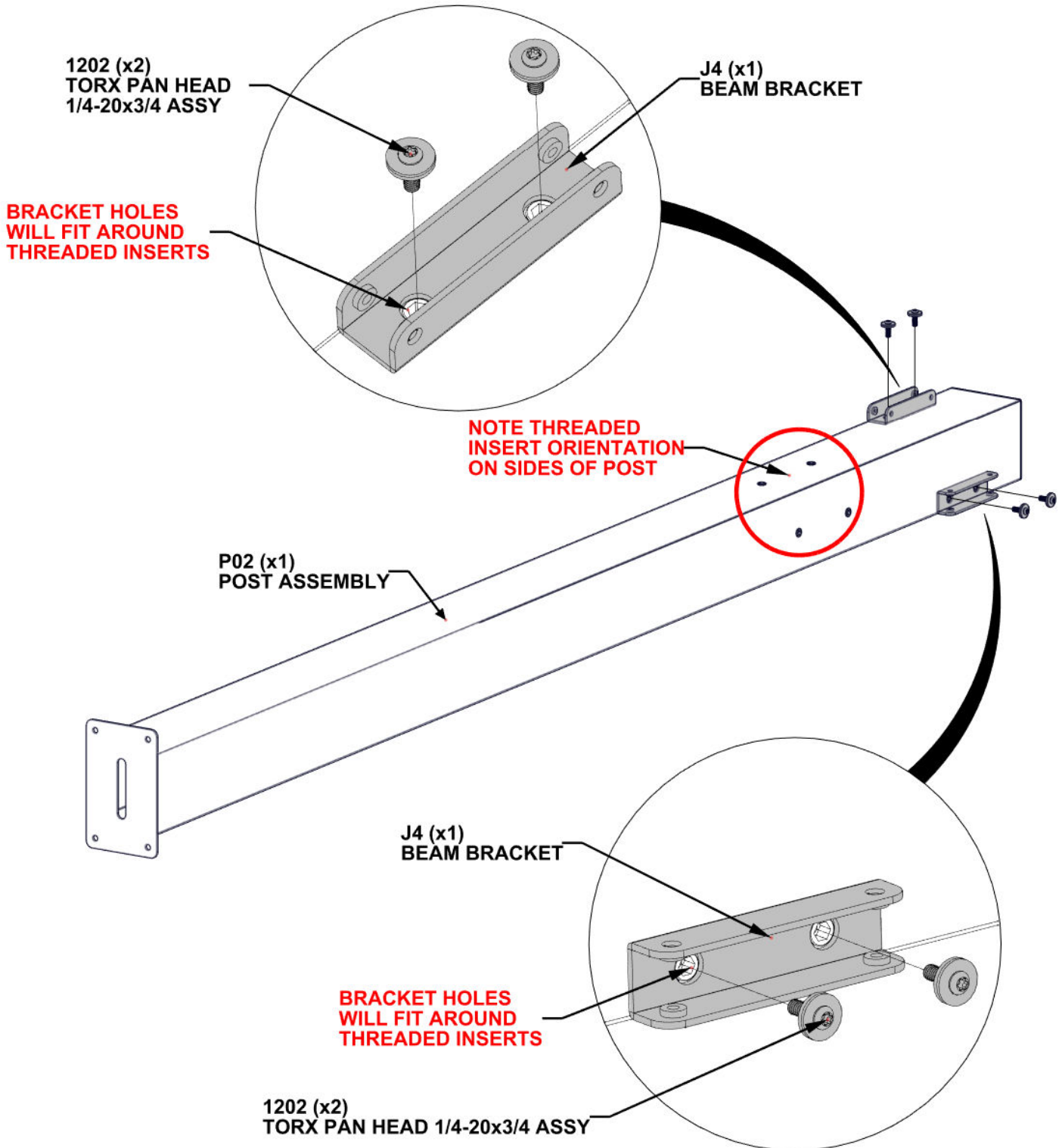

STEP 7 - POST ASSEMBLY

Qty	PartNo	Description
4	H101202	TORX PAN HEAD 1/4-20x3/4 ASSY

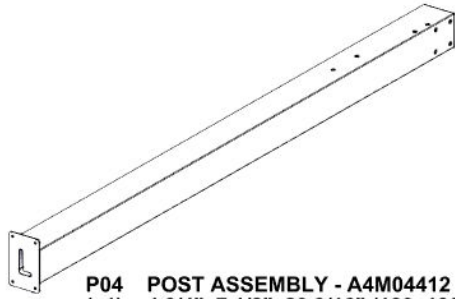

P04 POST ASSEMBLY - A4M04412
 (x1) 4 3/4"x7 1/2"x89 9/16" (120x190x2275)

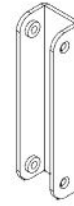

J4 BEAM BRACKET - A4M02990
 (x2) 1"x1 5/16"x5 1/16" (25x33.2x128)

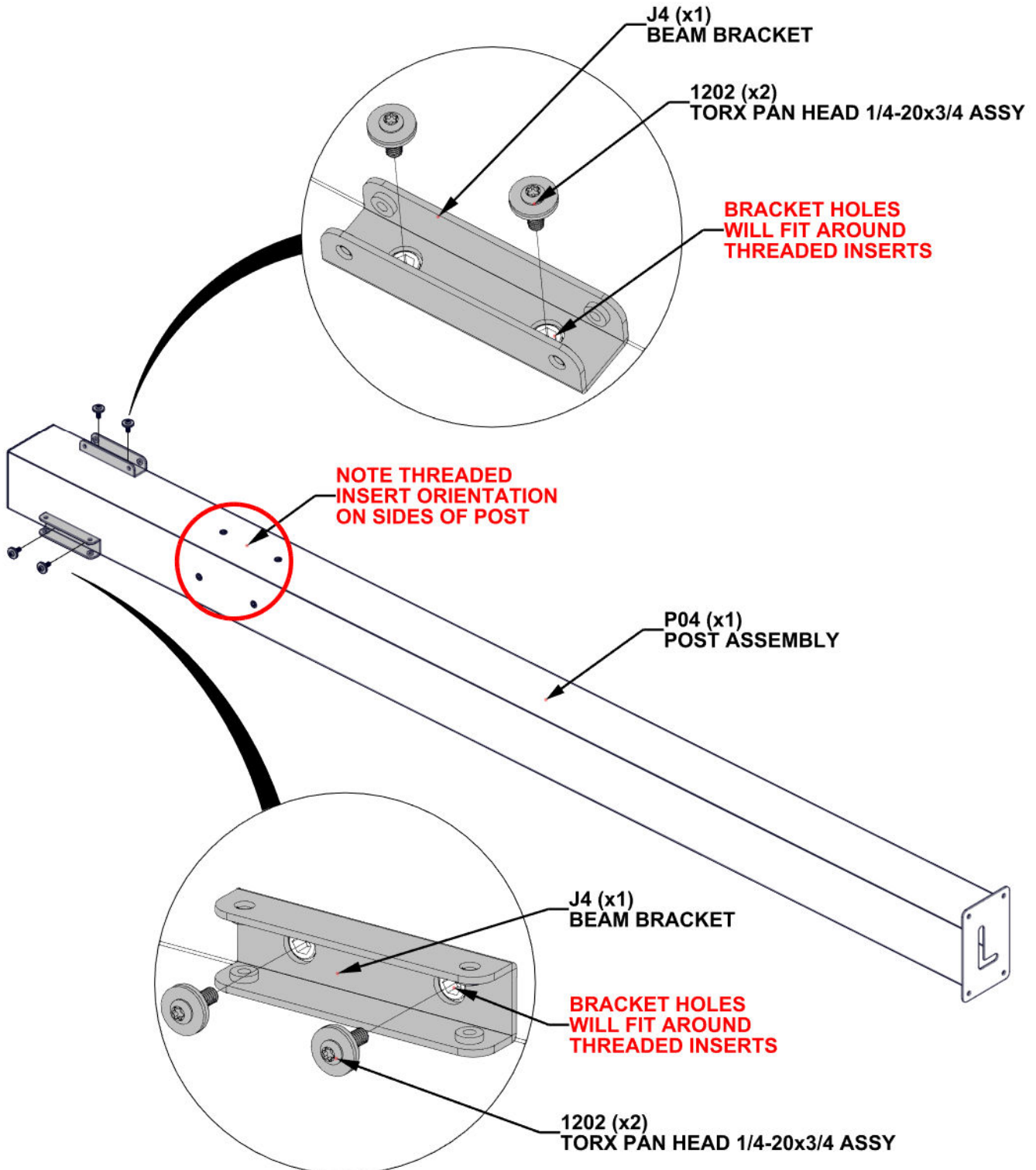

STEP 8A - FRAME ASSEMBLY

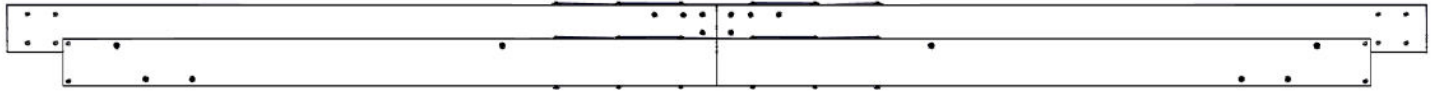

BEAM ASSEMBLY FROM STEPS 1 - 5

- SLIDE EACH POST ASSEMBLY INTO THE BEAM ASSEMBLY FROM STEPS 1 - 5.

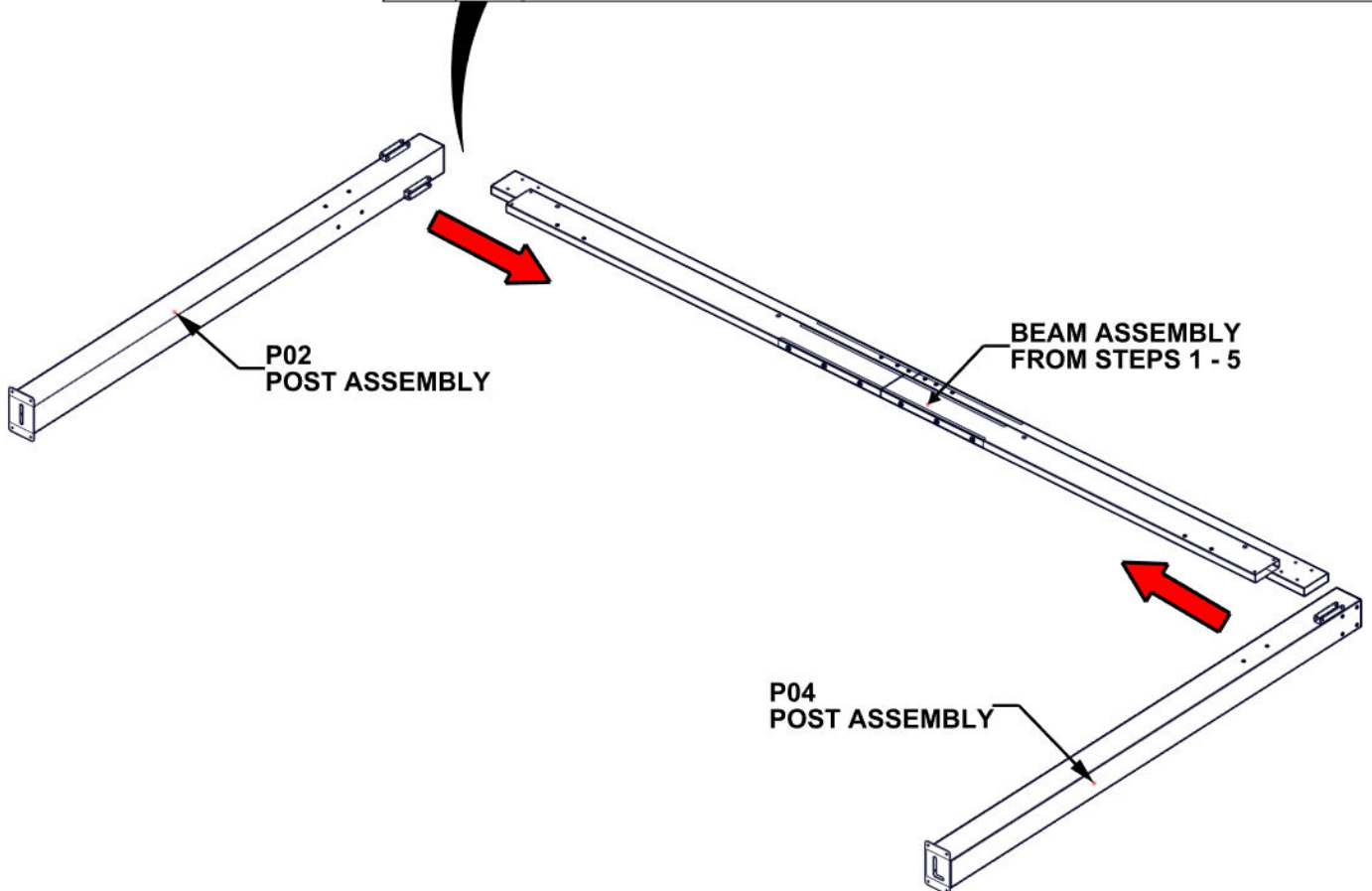
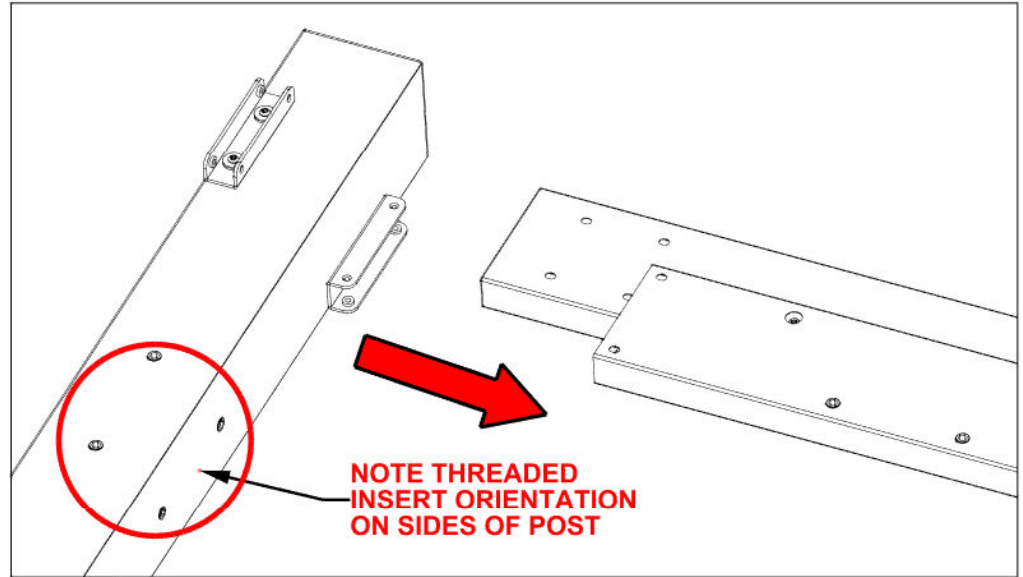

STEP 8B - FRAME ASSEMBLY

Qty	PartNo	Description
4	H101202	TORX PAN HEAD 1/4-20x3/4 ASSY

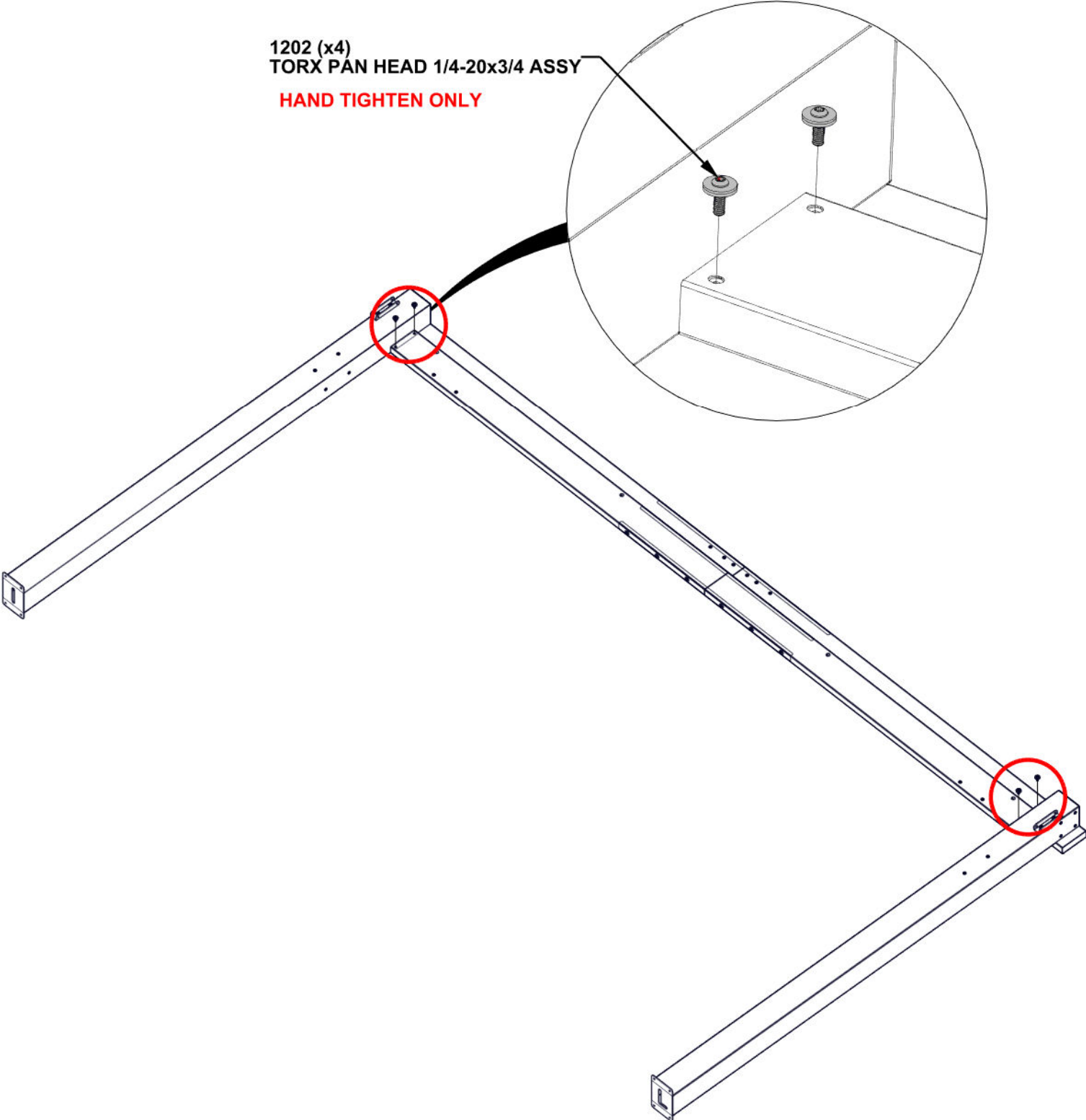

STEP 8C - FRAME ASSEMBLY

Qty	PartNo	Description
8	H101202	TORX PAN HEAD 1/4-20x3/4 ASSY



C01 CORBEL ASSEMBLY - A4M03525
(x1) 21 13/16"x5 1/4"x2 3/4" (70x134x553.5)



C02 CORBEL ASSEMBLY - A4M03526
(x1) 21 13/16"x5 1/4"x2 3/4" (70x134x553.5)

- ATTACH CORBELS TO BEAM AND POST.
- **SQUARE AS NEEDED BEFORE TIGHTENING ALL HARDWARE FROM PREVIOUS STEPS.**
- **TIGHTEN ALL HARDWARE.**

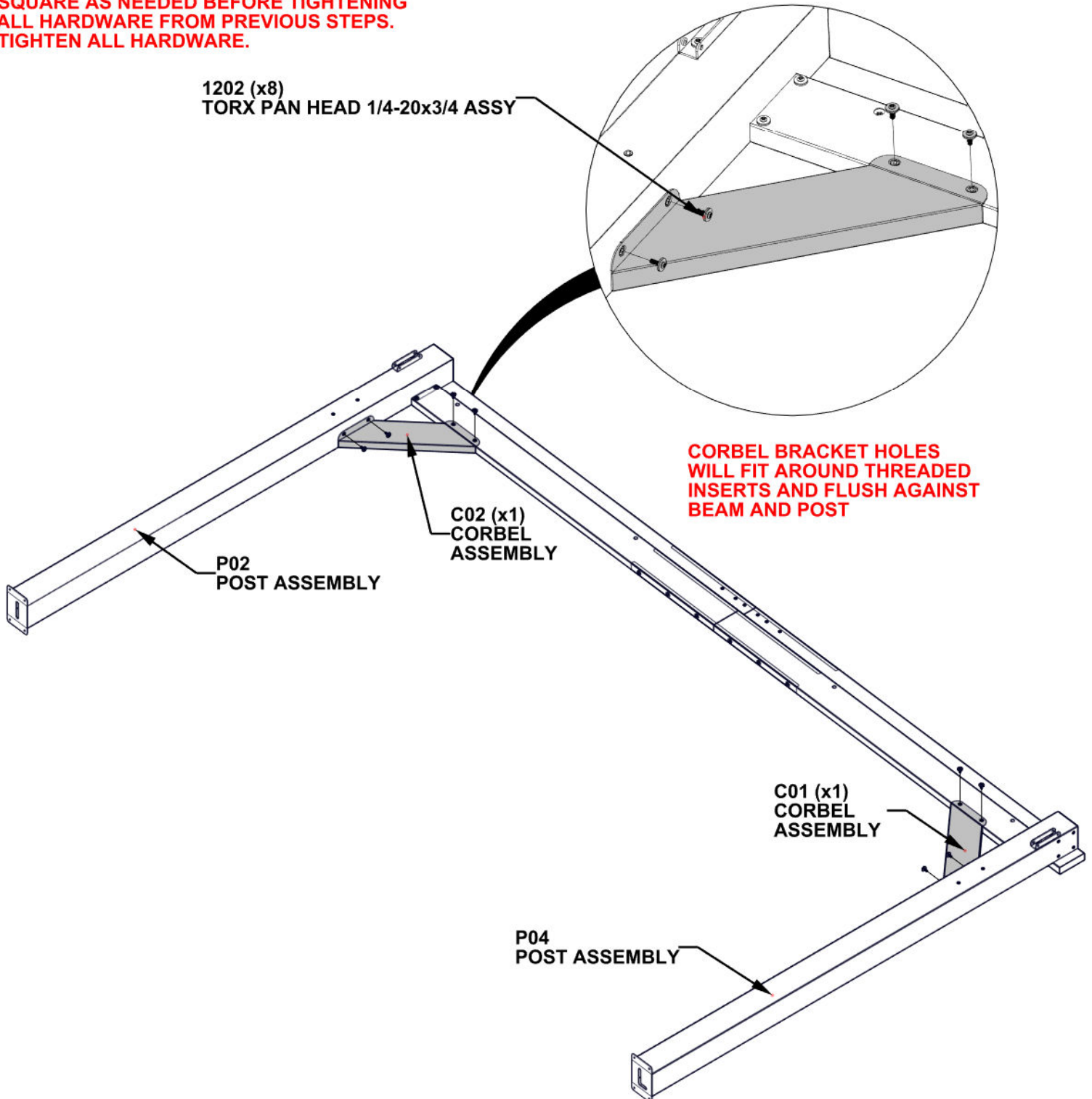

STEP 8D - FRAME ASSEMBLY

Qty	PartNo	Description
8	H101103	TORX SOCKET SCREW 1/4-20

- WITH AN ADDITIONAL PERSON, TURN OVER POST AND BEAM ASSEMBLY

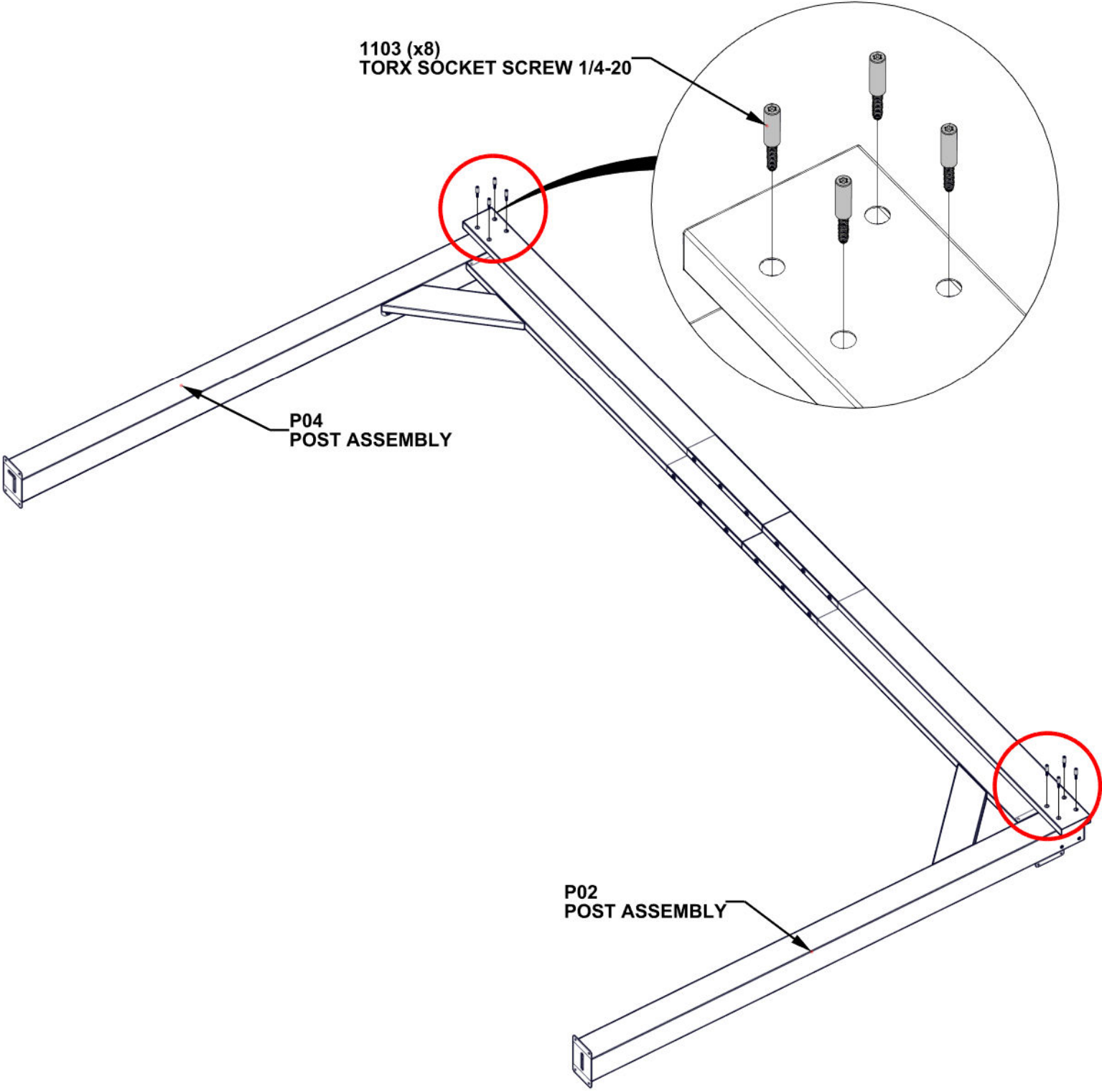

STEP 9A - BEAM ASSEMBLY

Qty	PartNo	Description
6	H101202	TORX PAN HEAD 1/4-20x3/4 ASSY



B17 SIDE BEAM ASSEMBLY - A4M04416
(x1) 79 11/16"x5 1/4"x1 7/16" (36x134x2023.90)



J1 SPLICE BRACKET - A4M02230
(x1) 1 5/16"x5 3/16"x39 3/8" (33.2x131.2x1000)

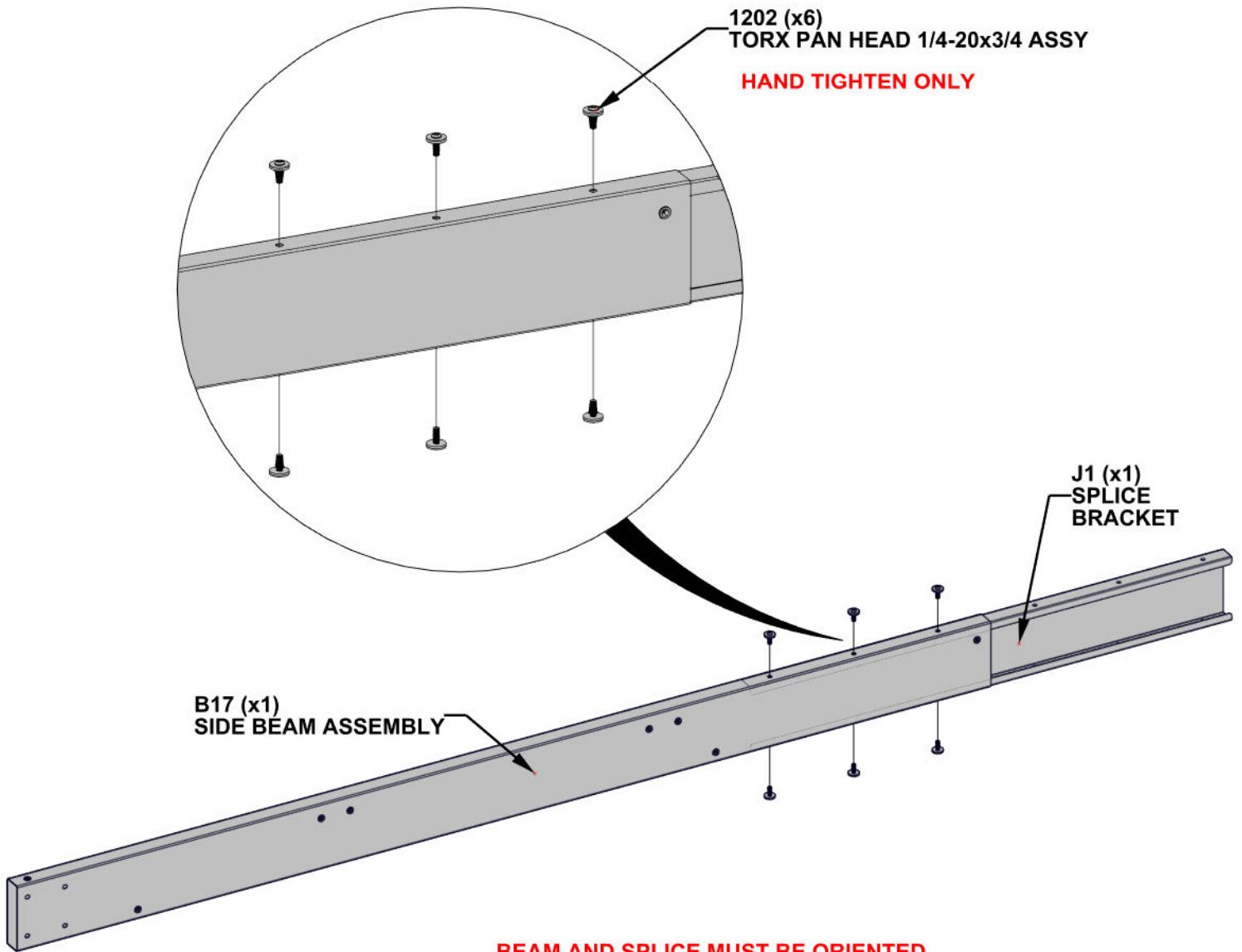

BEAM AND SPLICE MUST BE ORIENTED AS SHOWN ABOVE. SLIDE J1 INTO B17 AND LINE UP THREE HOLES TOP AND BOTTOM

STEP 9B - BEAM ASSEMBLY

Qty	PartNo	Description
6	H101202	TORX PAN HEAD 1/4-20x3/4 ASSY



B01 SIDE BEAM ASSEMBLY - A4M04415
(x1) 79 11/16"x5 1/4"x1 7/16" (36x134x2023.90)

- SLIDE B01 ONTO SPLICE BRACKET.
GENTLY TAP ENDS OF ASSEMBLY WITH
RUBBER Mallet UNTIL GAP CLOSES.

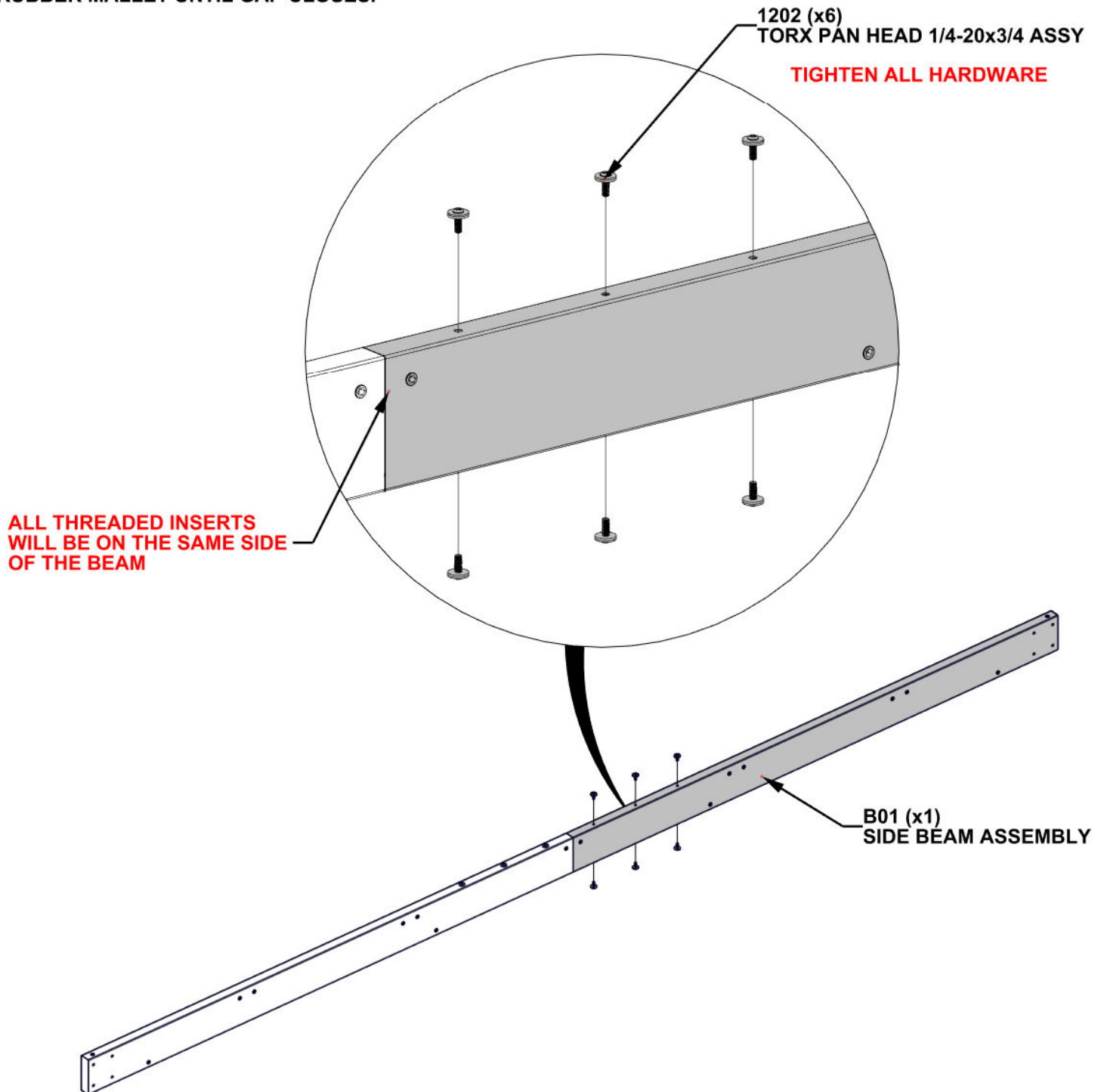

STEP 9C - BEAM ASSEMBLY

Qty	PartNo	Description
6	H101202	TORX PAN HEAD 1/4-20x3/4 ASSY



B16 SIDE BEAM ASSEMBLY - A4M04414
(x1) 74 7/8"x5 1/4"x1 7/16" (36x134x1901.40)



J1 SPLICE BRACKET - A4M02230
(x1) 1 5/16"x5 3/16"x39 3/8" (33.2x131.2x1000)

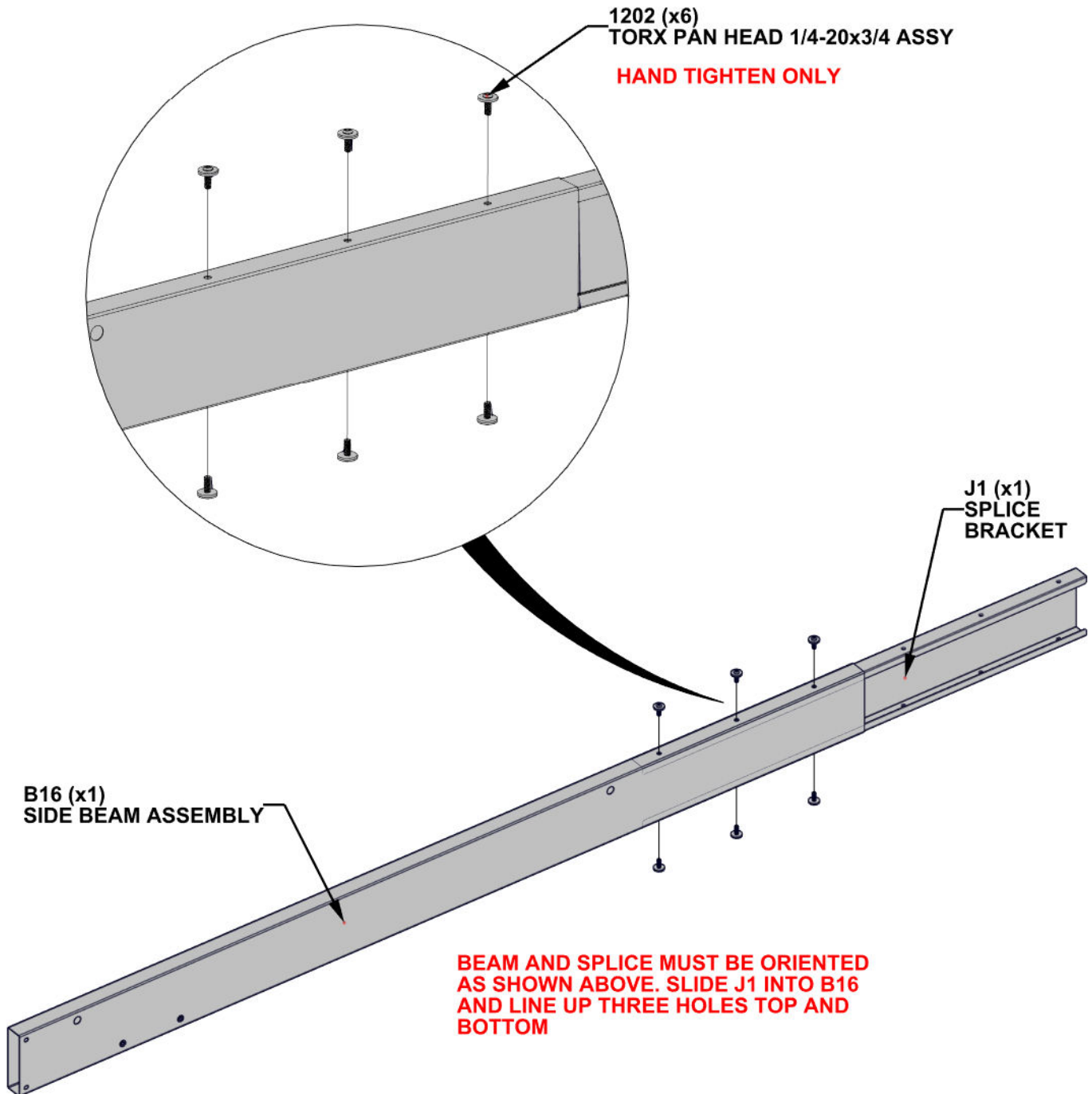

STEP 9D - BEAM ASSEMBLY

Qty	PartNo	Description
6	H101202	TORX PAN HEAD 1/4-20x3/4 ASSY



B02 SIDE BEAM ASSEMBLY - A4M04413
(x1) 74 7/8"x5 1/4"x1 7/16" (36x134x1901.40)

- SLIDE B02 ONTO SPLICE BRACKET.
GENTLY TAP ENDS OF ASSEMBLY WITH
RUBBER MALLET UNTIL GAP CLOSSES.

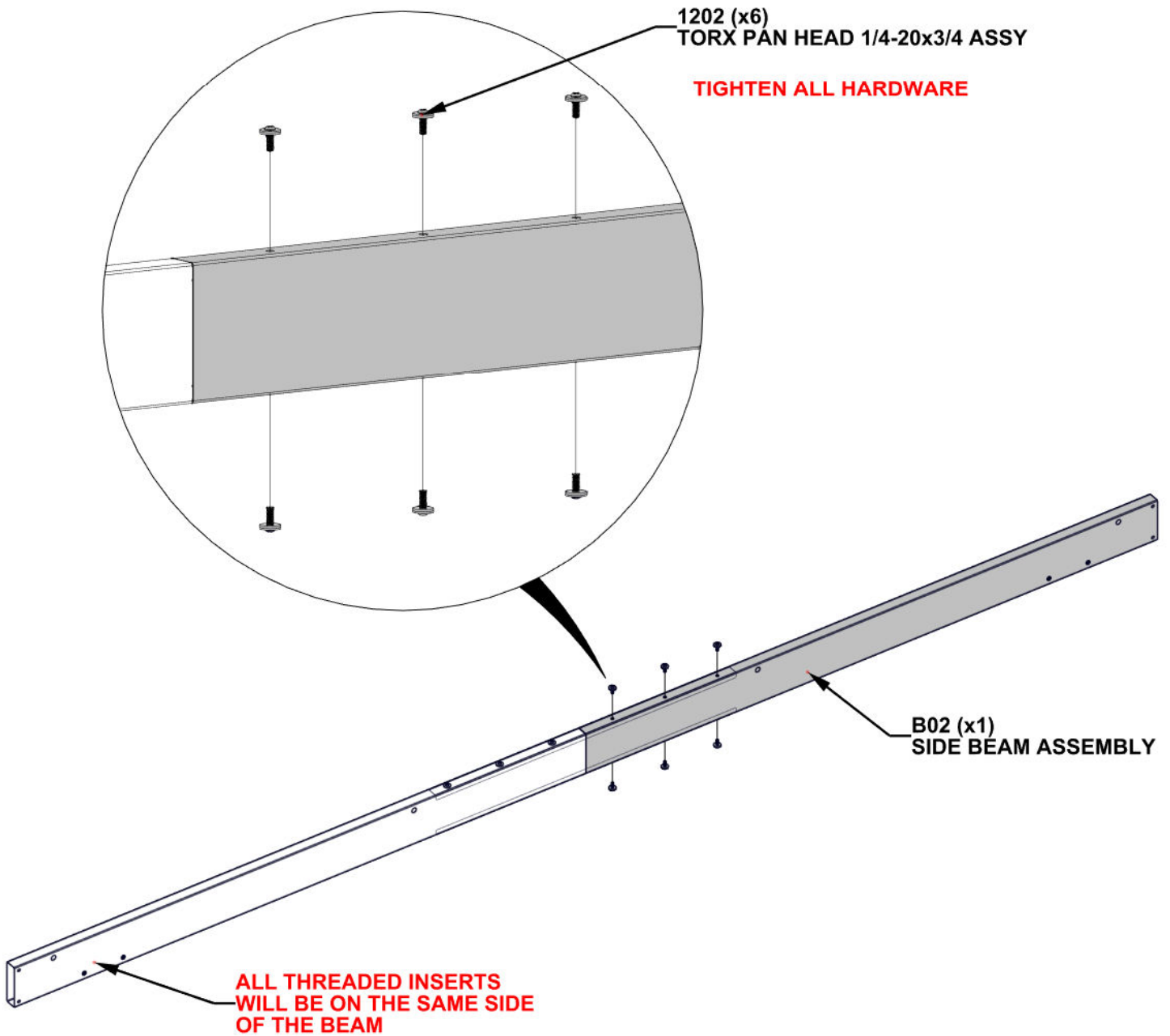

STEP 9E - BEAM ASSEMBLY

Qty	PartNo	Description
4	H101103	TORX SOCKET SCREW 1/4-20

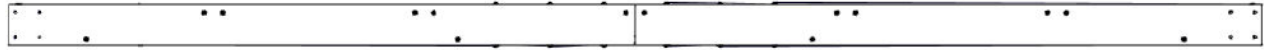

UPPER BEAM ASSEMBLY FROM STEP 9A-9B



LOWER BEAM ASSEMBLY FROM STEP 9C-9D

- ALIGN THROUGH HOLES IN LOWER BEAM ASSEMBLY WITH THREADED INSERTS IN UPPER BEAM ASSEMBLY

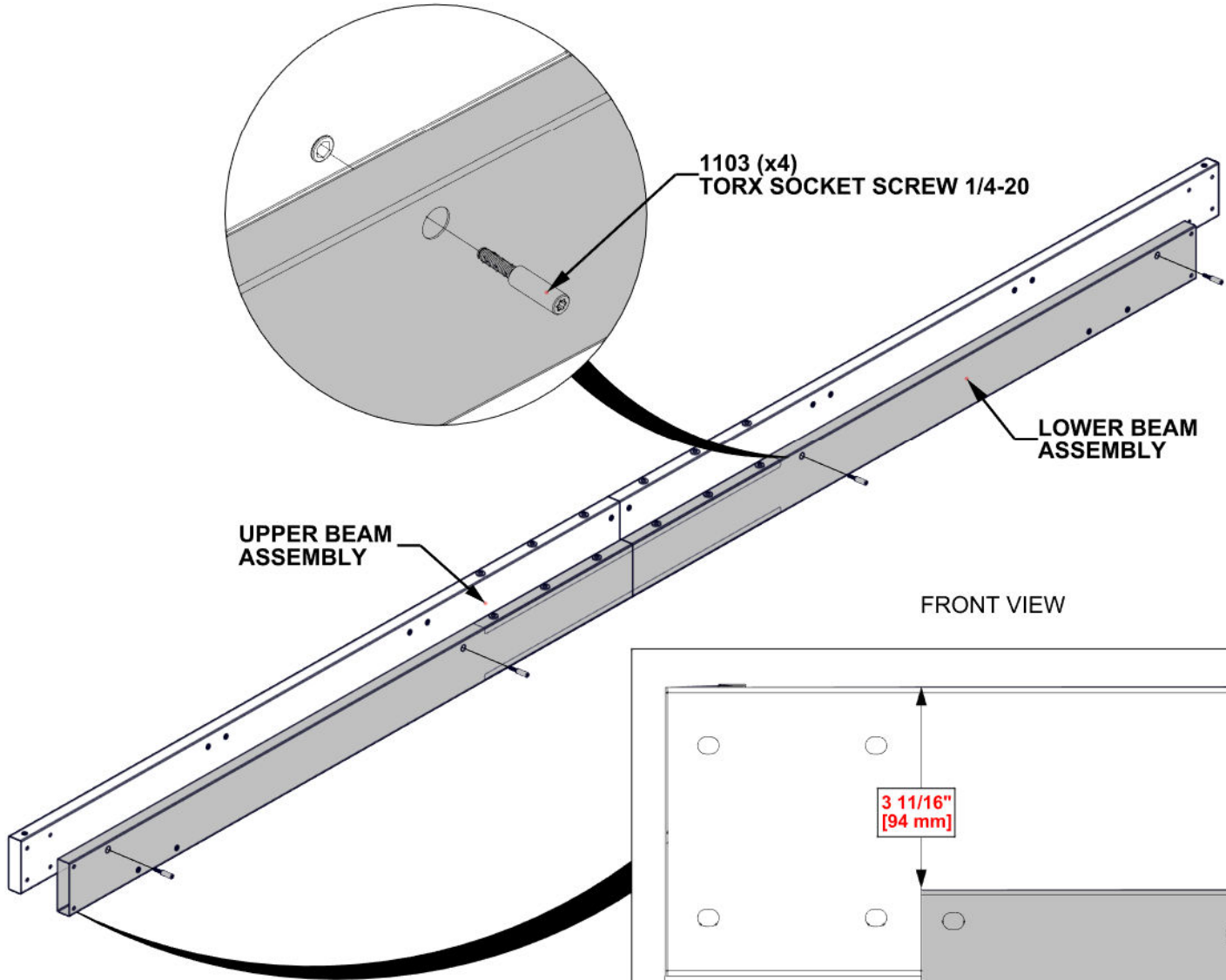

FRONT VIEW

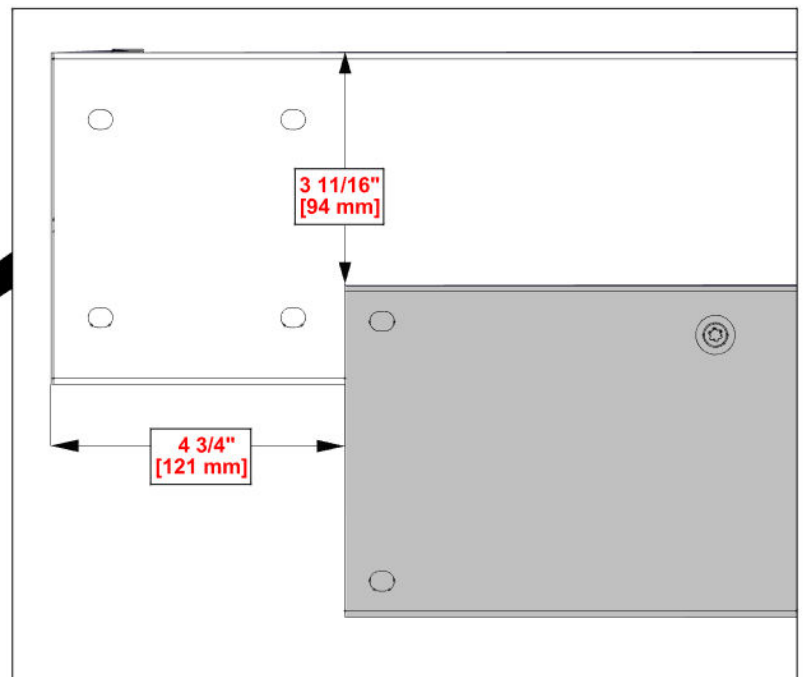

DIMENSIONS ARE THE SAME AT BOTH ENDS AND CRITICAL TO THE BEAM ASSEMBLY

STEP 10 - BEAM ASSEMBLY

Qty	PartNo	Description
10	H101202	TORX PAN HEAD 1/4-20x3/4 ASSY

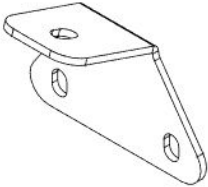

J5 RAFTER BRACKET - A4M03803
(x5) 3 5/8"x2 11/16"x2 1/16" (52x68x91.5)

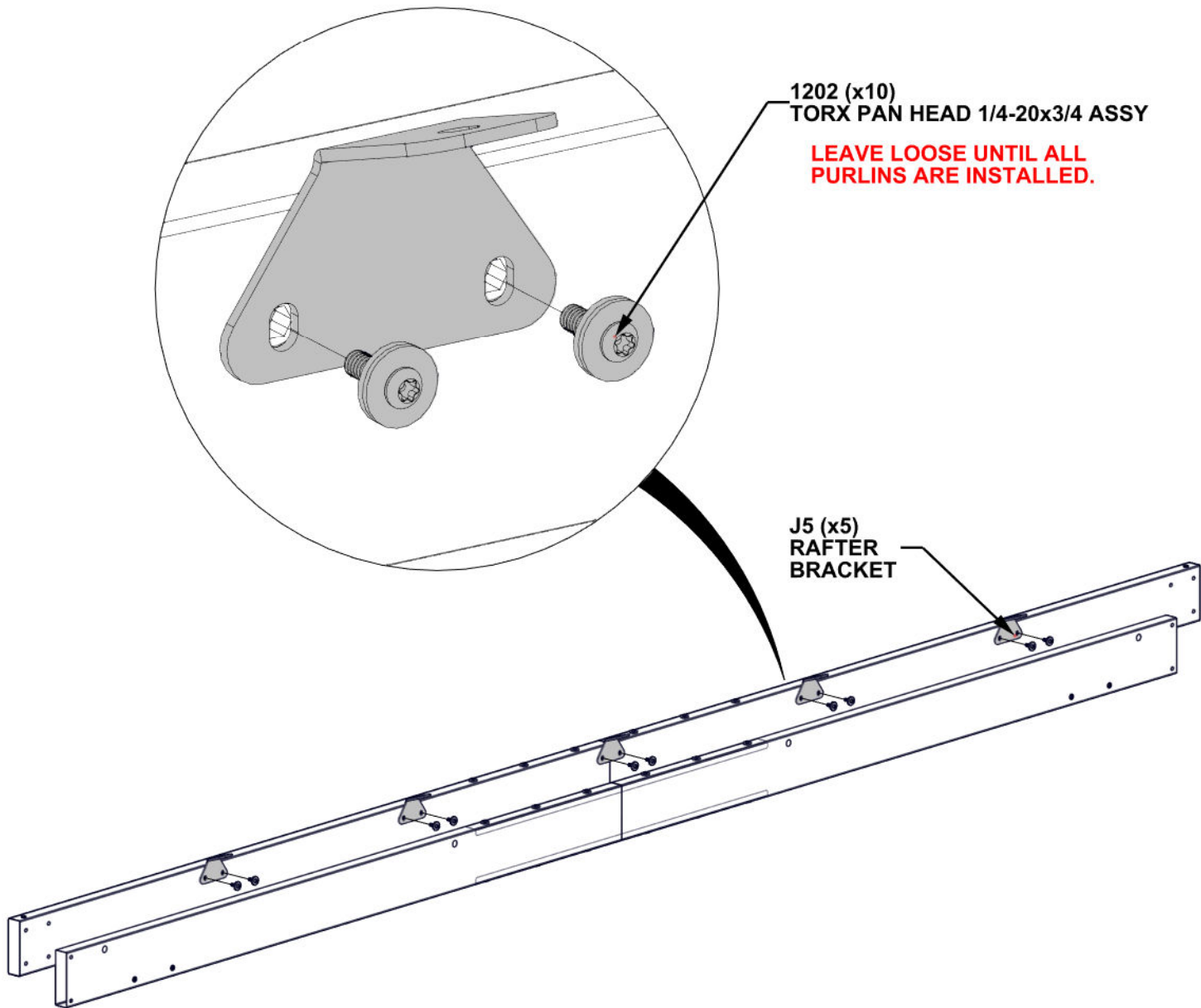

**REPEAT BEAM ASSEMBLY
STEPS 9 THROUGH 10**

STEP 11 - POST ASSEMBLY

Qty	PartNo	Description
4	H101202	TORX PAN HEAD 1/4-20x3/4 ASSY

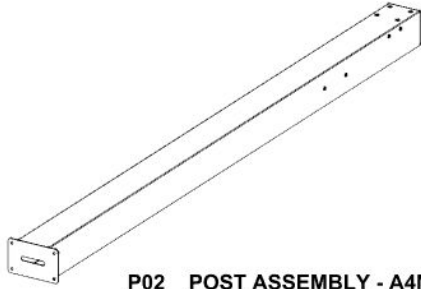

P02 POST ASSEMBLY - A4M04410
(x1) 4 3/4"x7 1/2"x89 9/16" (120x190x2275)

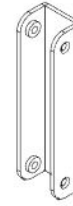

J4 BEAM BRACKET - A4M02990
(x2) 1"x1 5/16"x5 1/16" (25x33.2x128)

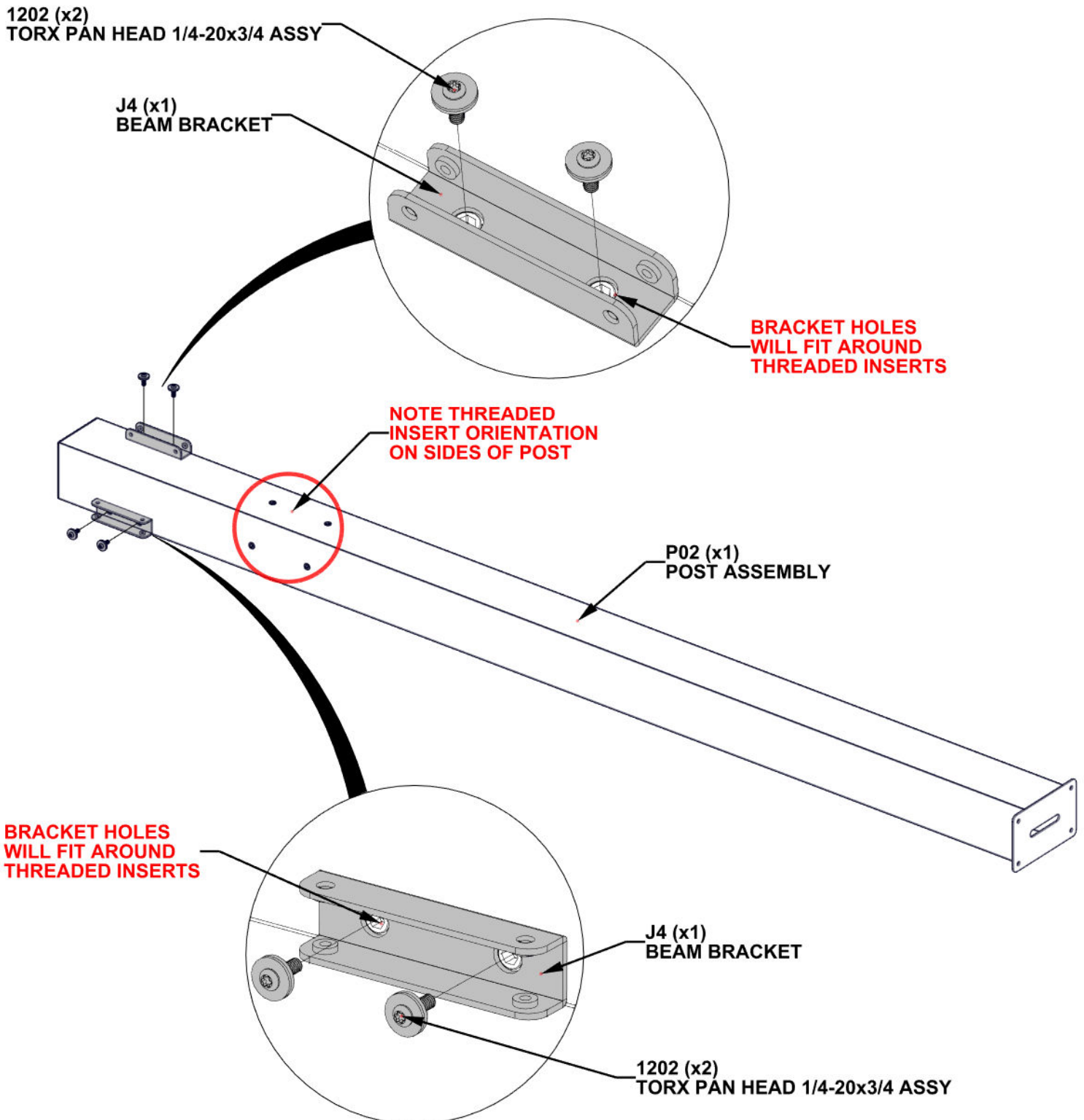

STEP 12A - FRAME ASSEMBLY

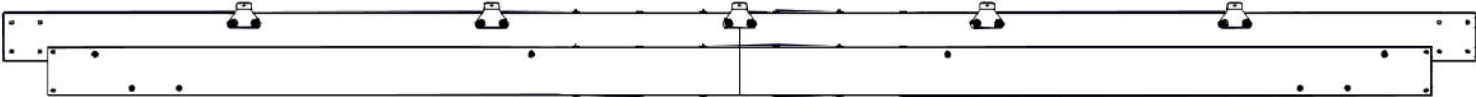

BEAM ASSEMBLY FROM STEPS 9 - 10

- SLIDE POST ASSEMBLY FROM STEP 11 INTO THE BEAM ASSEMBLY FROM STEPS 9 - 10.

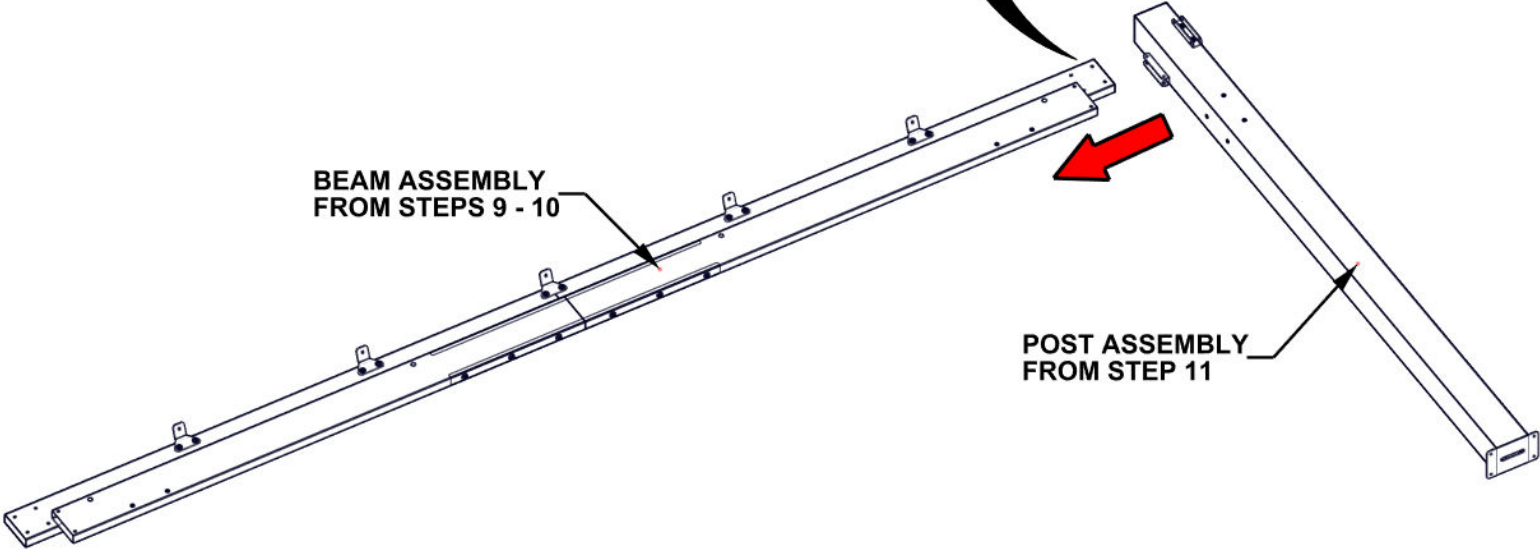
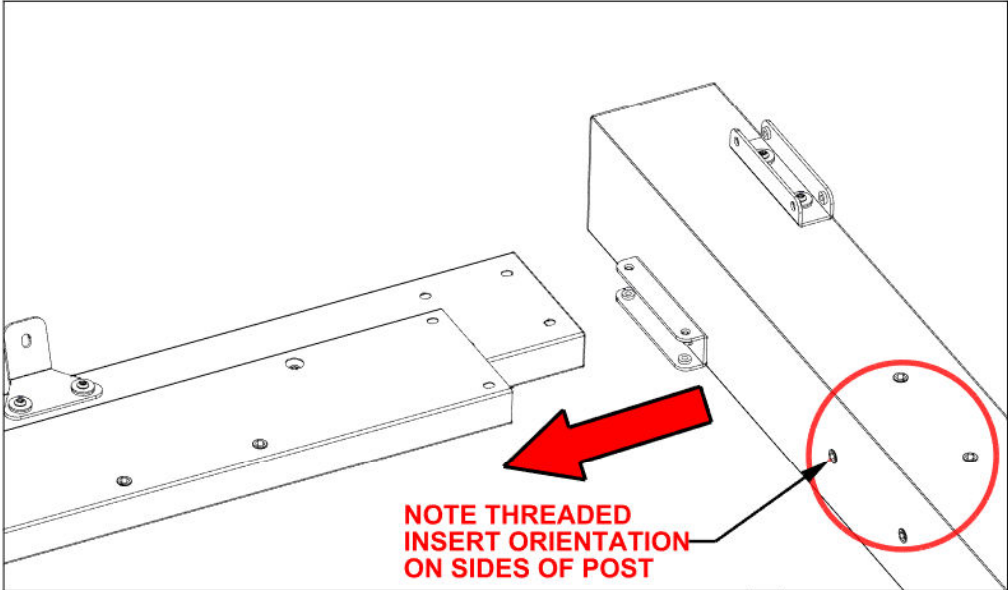

STEP 12B - FRAME ASSEMBLY

Qty	PartNo	Description
2	H101202	TORX PAN HEAD 1/4-20x3/4 ASSY

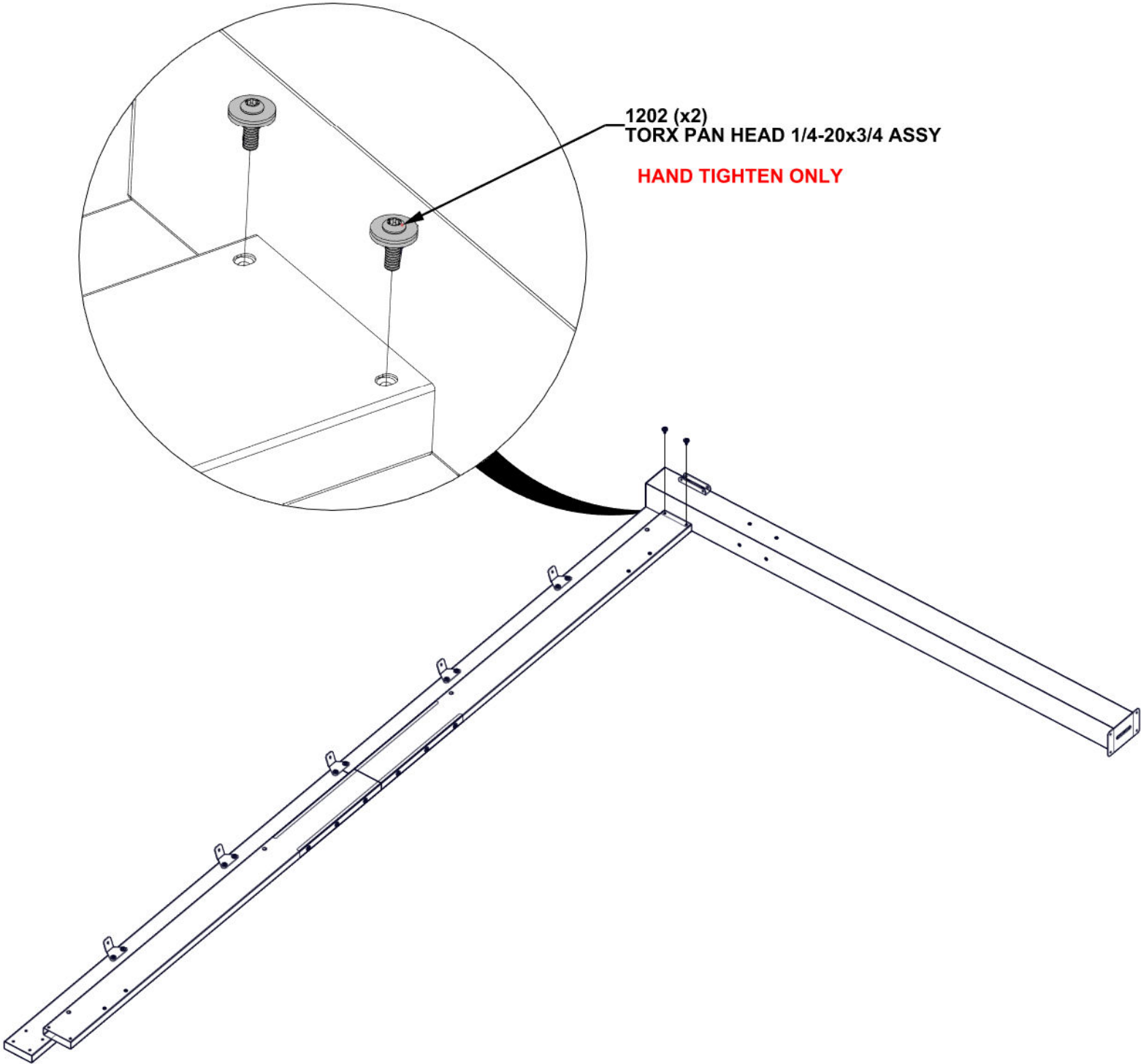

STEP 12C - FRAME ASSEMBLY

Qty	PartNo	Description
4	H101202	TORX PAN HEAD 1/4-20x3/4 ASSY



C01 CORBEL ASSEMBLY - A4M03525
(x1) 21 13/16"x5 1/4"x2 3/4" (70x134x553.5)

- ATTACH CORBEL TO BEAM AND POST.
- **SQUARE AS NEEDED BEFORE TIGHTENING ALL HARDWARE FROM PREVIOUS STEPS.**

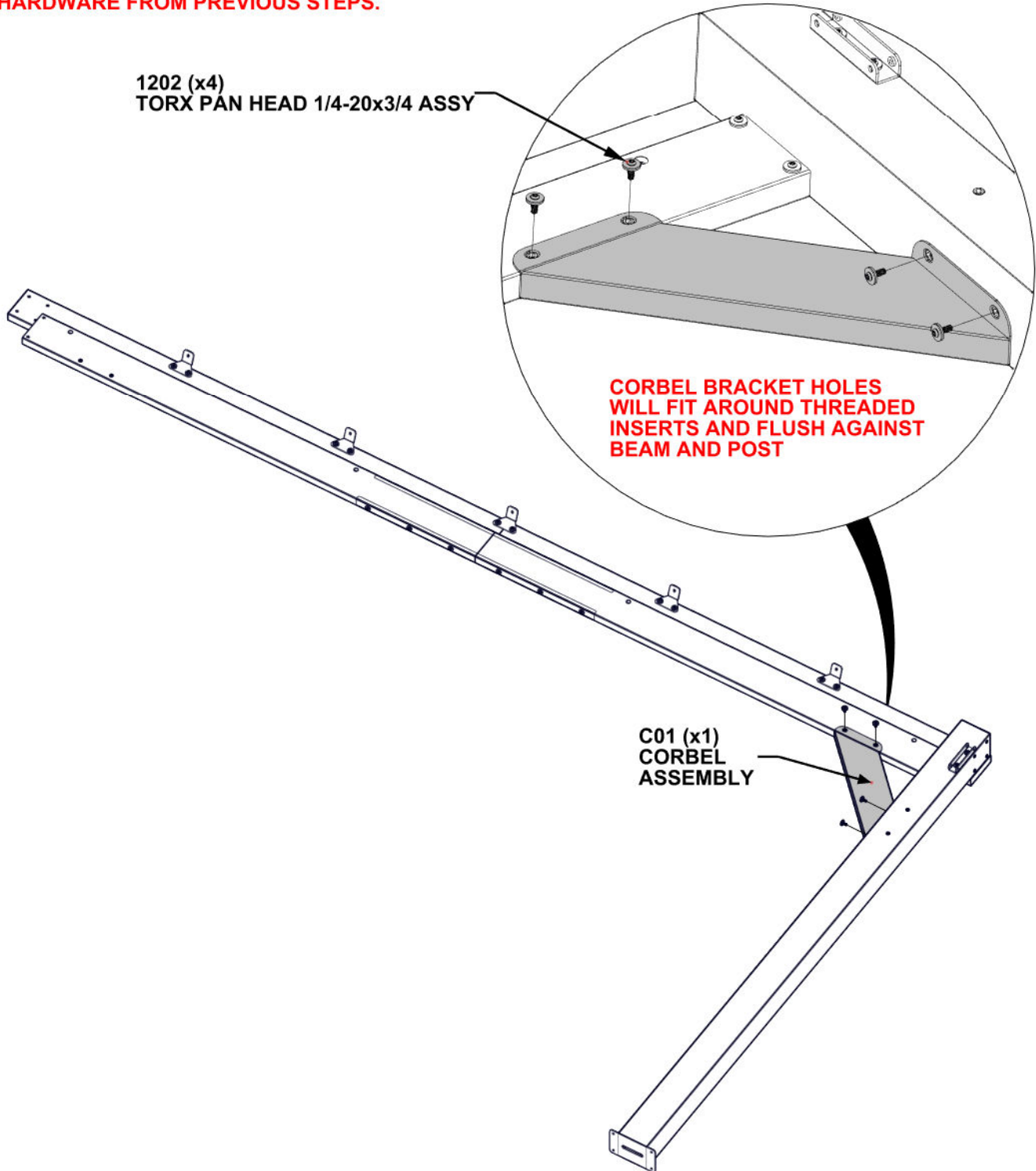

1202 (x4)
TORX PAN HEAD 1/4-20x3/4 ASSY

C01 (x1)
CORBEL
ASSEMBLY

**CORBEL BRACKET HOLES
WILL FIT AROUND THREADED
INSERTS AND FLUSH AGAINST
BEAM AND POST**

STEP 13A - FRAME ASSEMBLY

- WITH AT LEAST THREE OTHER PEOPLE, ATTACH BEAM AND POST ASSEMBLIES BY SLIDING INTO PLACE.

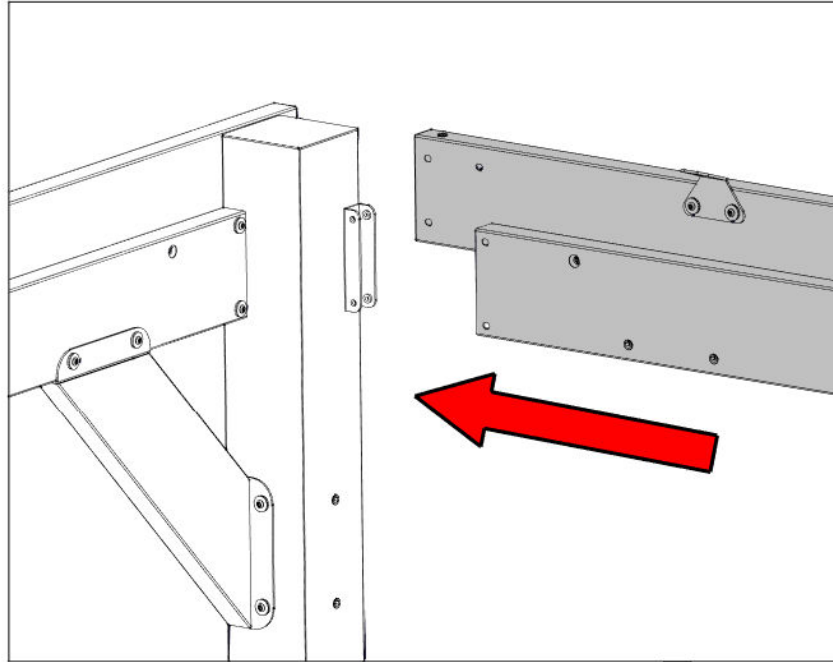

BEAM AND POST ASSEMBLY
STEPS FROM 8A - 8D

BEAM AND POST ASSEMBLY
STEPS FROM 11 - 12

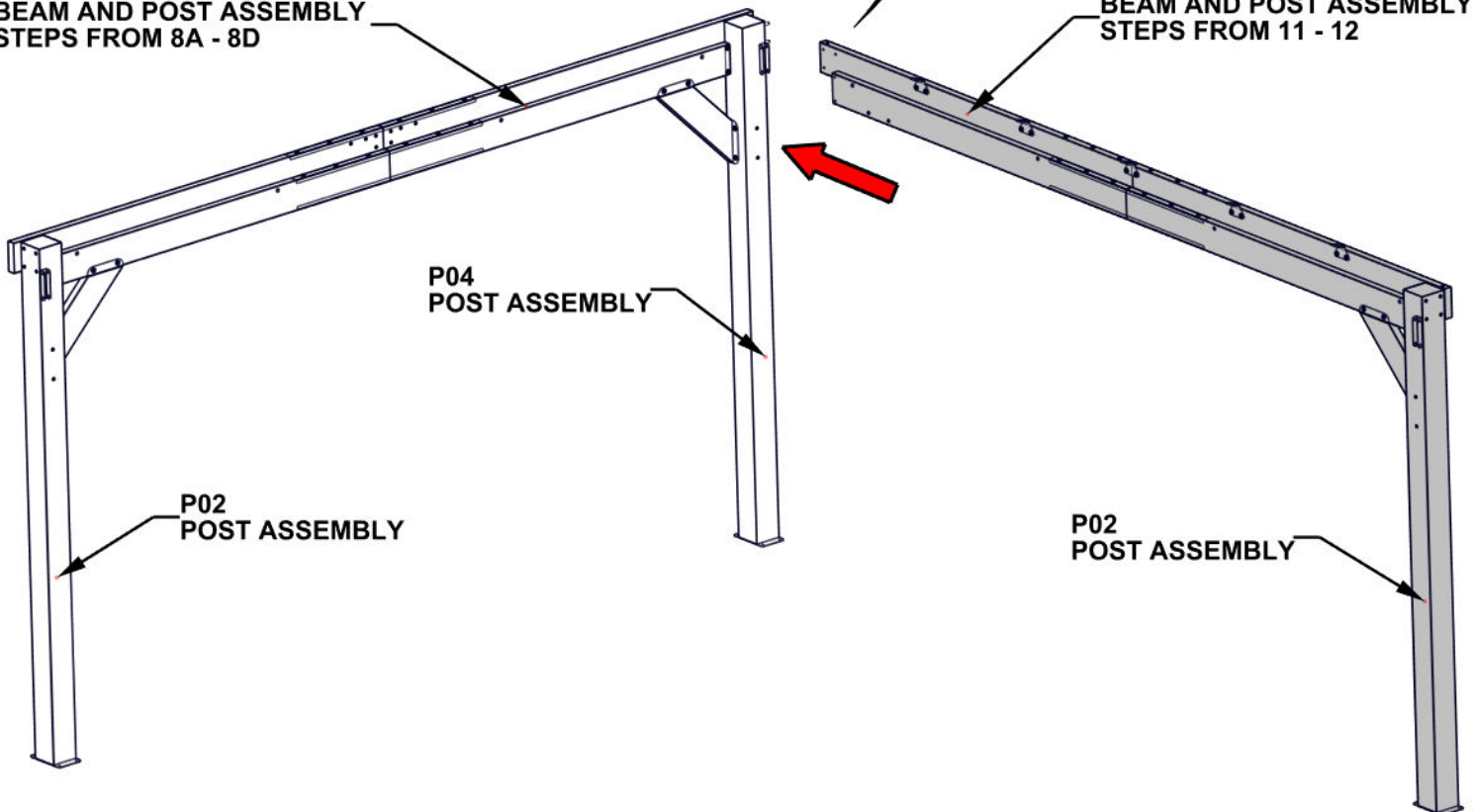

STEP 13B - FRAME ASSEMBLY

Qty	PartNo	Description
4	H101103	TORX SOCKET SCREW 1/4-20

1103 (x4)
TORX SOCKET SCREW 1/4-20
HAND TIGHTEN ONLY

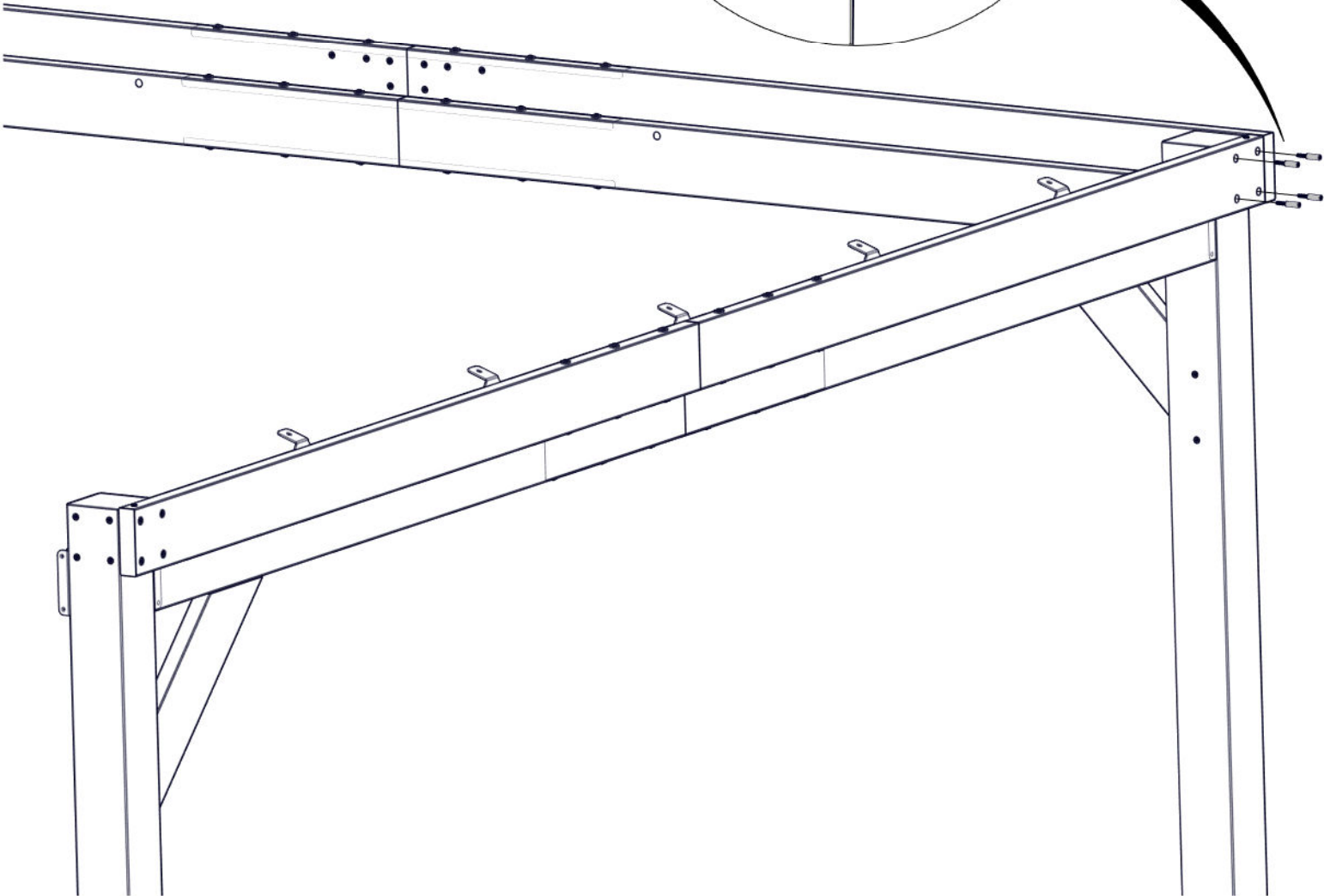
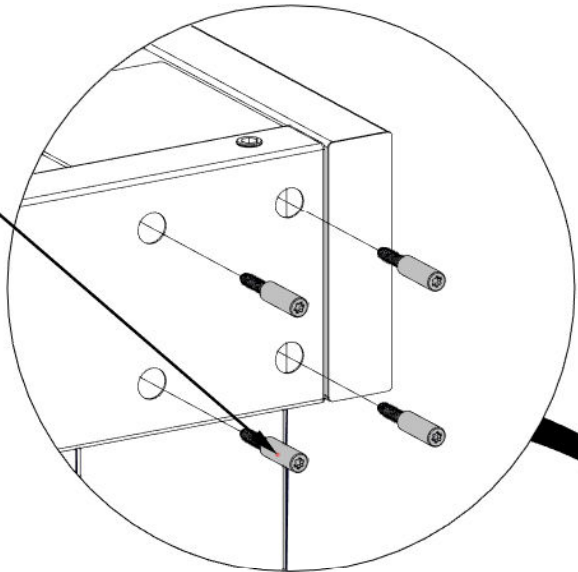

STEP 13C - FRAME ASSEMBLY

Qty	PartNo	Description
4	H101103	TORX SOCKET SCREW 1/4-20

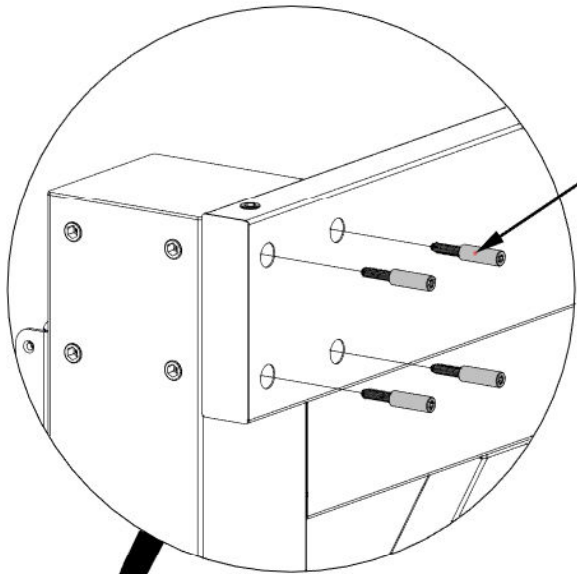

1103 (x4)
TORX SOCKET SCREW 1/4-20
HAND TIGHTEN ONLY

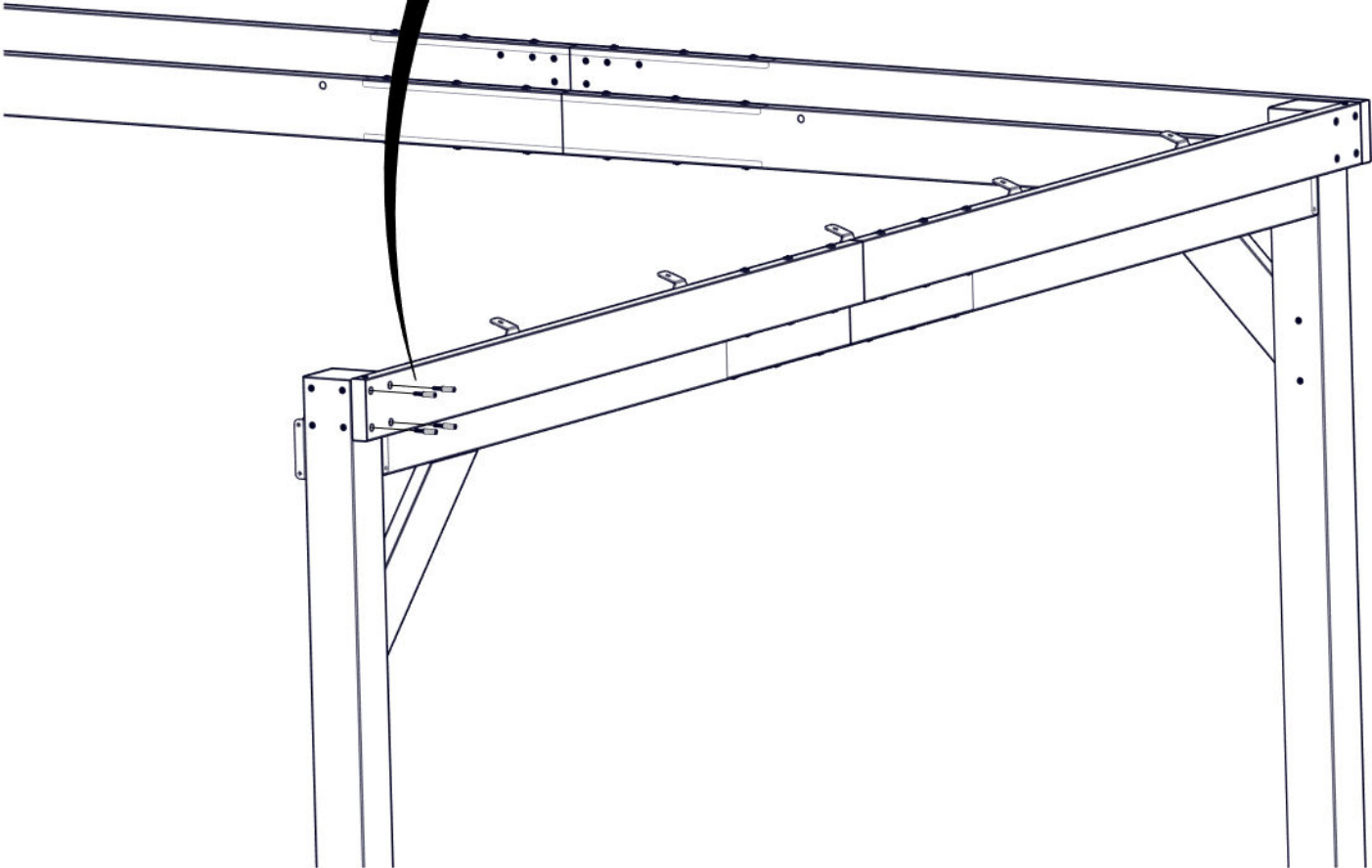

STEP 13D - FRAME ASSEMBLY

Qty	PartNo	Description
2	H101202	TORX PAN HEAD 1/4-20x3/4 ASSY

- SQUARE BEAM ASSEMBLY TO POST

1202 (x2)
TORX PAN HEAD 1/4-20x3/4 ASSY

TIGHTEN ALL HARDWARE

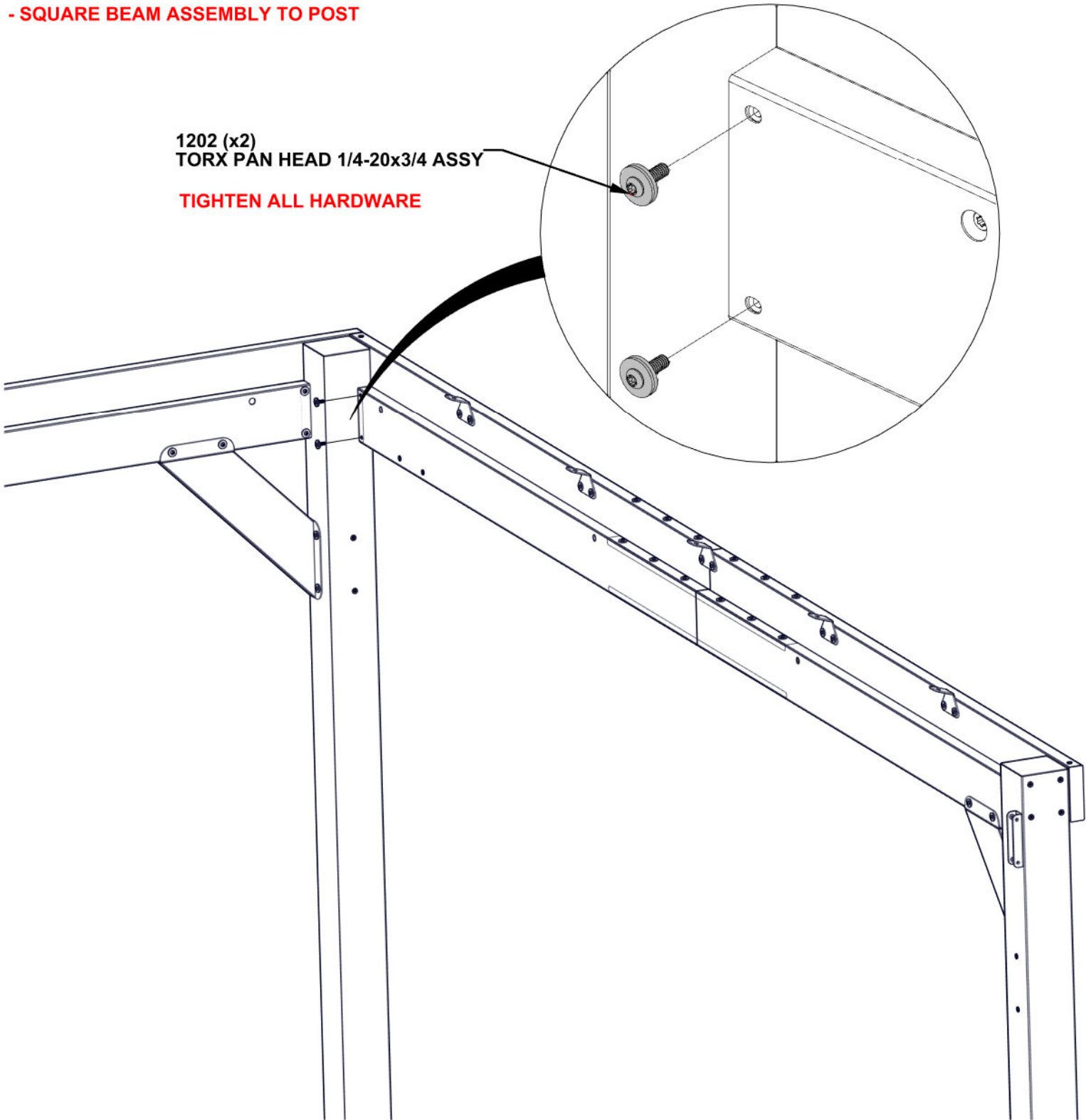

STEP 14 - FRAME ASSEMBLY

Qty	PartNo	Description
4	H101202	TORX PAN HEAD 1/4-20x3/4 ASSY



C02 CORBEL ASSEMBLY - A4M03526
(x1) 21 13/16"x5 1/4"x2 3/4" (70x134x553.5)

- ATTACH CORBEL TO BEAM AND POST.
- **SQUARE AS NEEDED BEFORE TIGHTENING ALL HARDWARE FROM PREVIOUS STEPS.**

1202 (x4)
TORX PAN HEAD 1/4-20x3/4 ASSY

**CORBEL BRACKET HOLES
WILL FIT AROUND THREADED
INSERTS AND FLUSH AGAINST
BEAM AND POST**

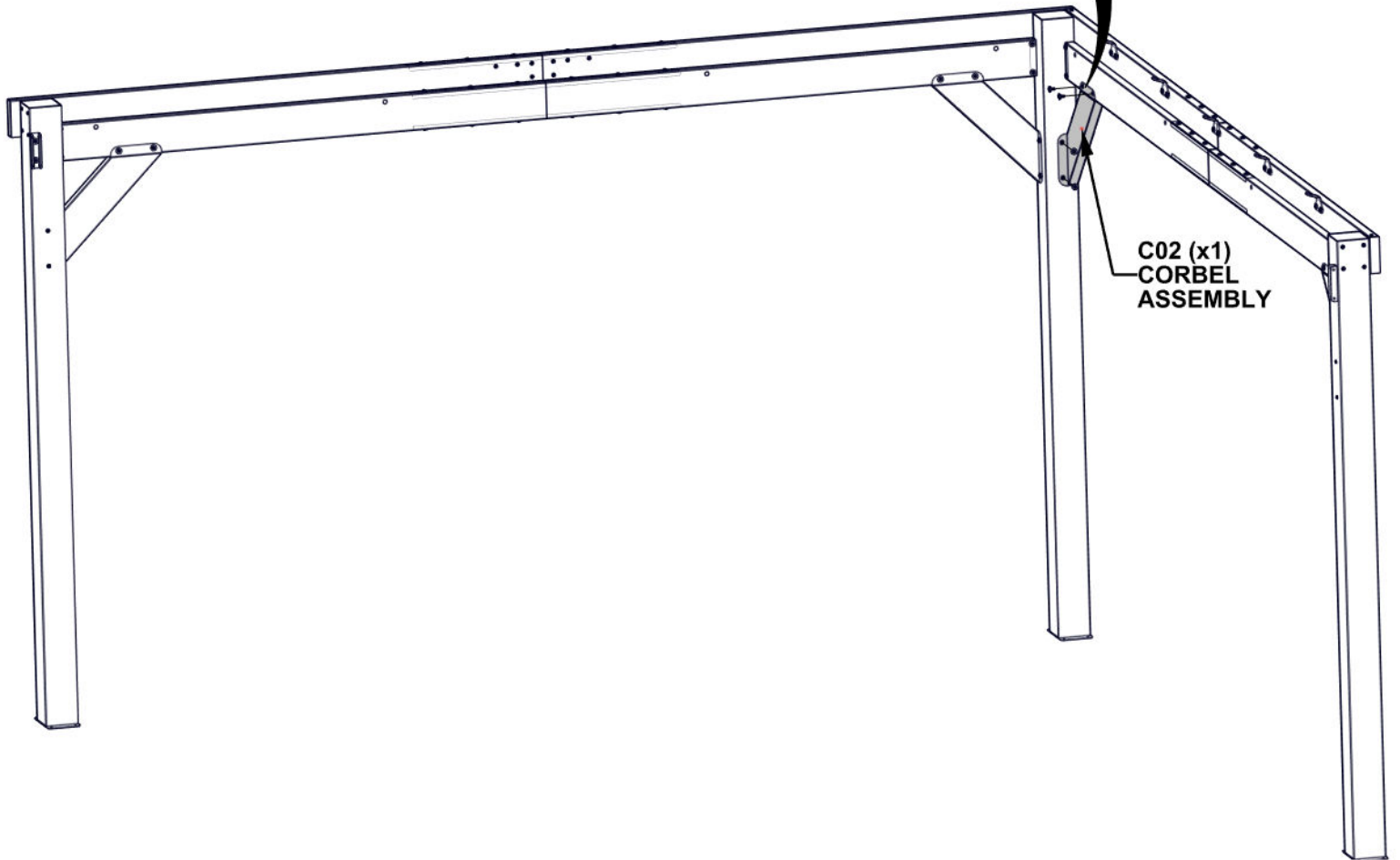
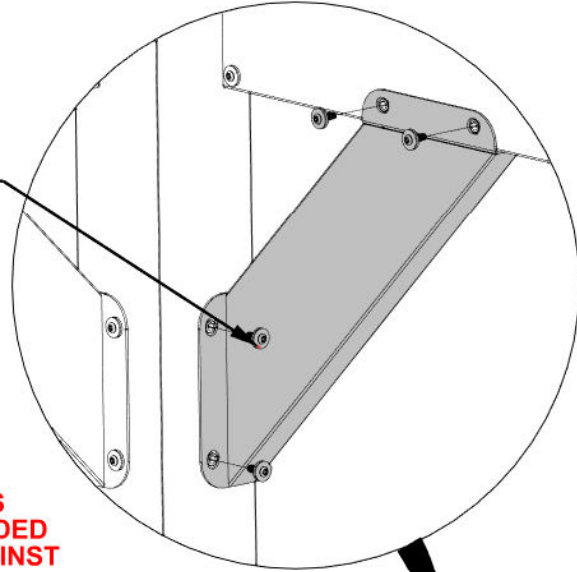

C02 (x1)
CORBEL
ASSEMBLY

STEP 15 - POST ASSEMBLY

Qty	PartNo	Description
4	H101202	TORX PAN HEAD 1/4-20x3/4 ASSY

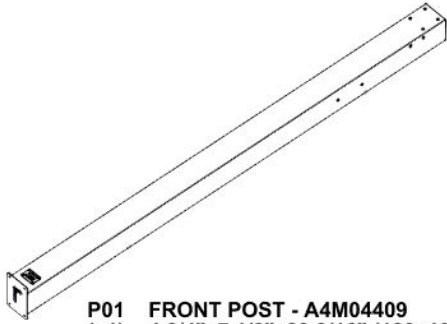

P01 FRONT POST - A4M04409
(x1) 4 3/4"x7 1/2"x89 9/16" (120x190x2275)

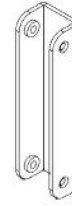

J4 BEAM BRACKET - A4M02990
(x2) 1"x1 5/16"x5 1/16" (25x33.2x128)

- FOR EASE OF ASSEMBLY, WE RECOMMEND USING SAW HORSES FOR STEPS 15 - 16.

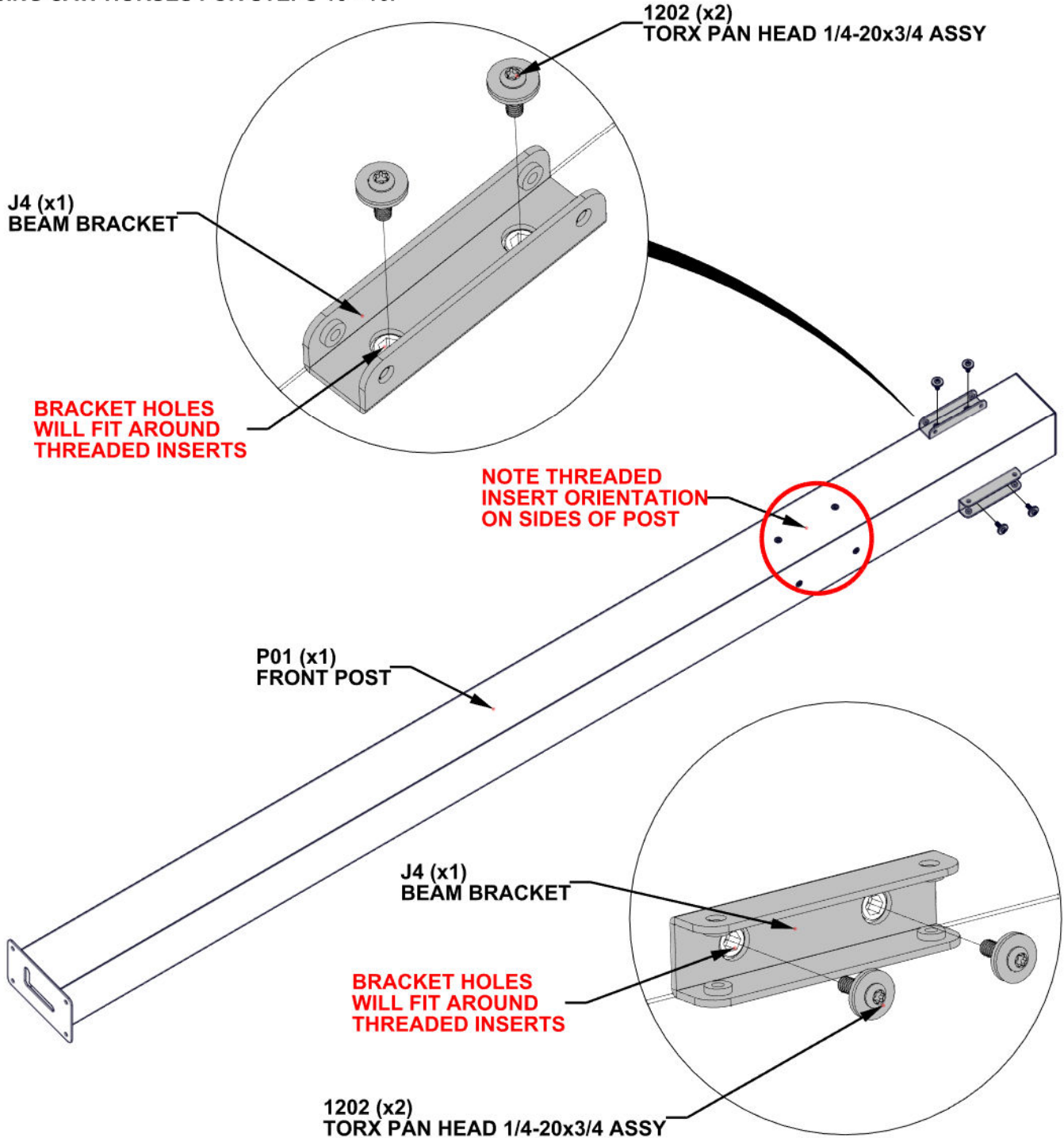

STEP 16A - FRAME ASSEMBLY



BEAM ASSEMBLY FROM STEPS 9 - 10

- SLIDE POST ASSEMBLY FROM STEP 15 INTO THE BEAM ASSEMBLY FROM STEPS 9 - 10.

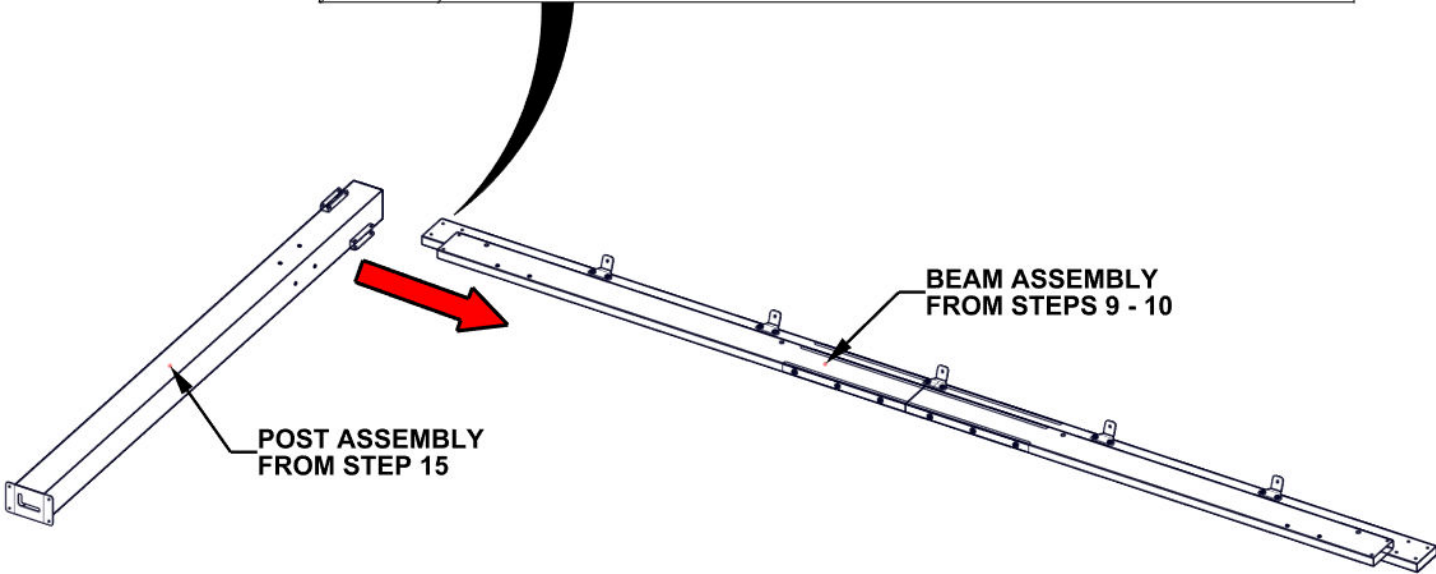
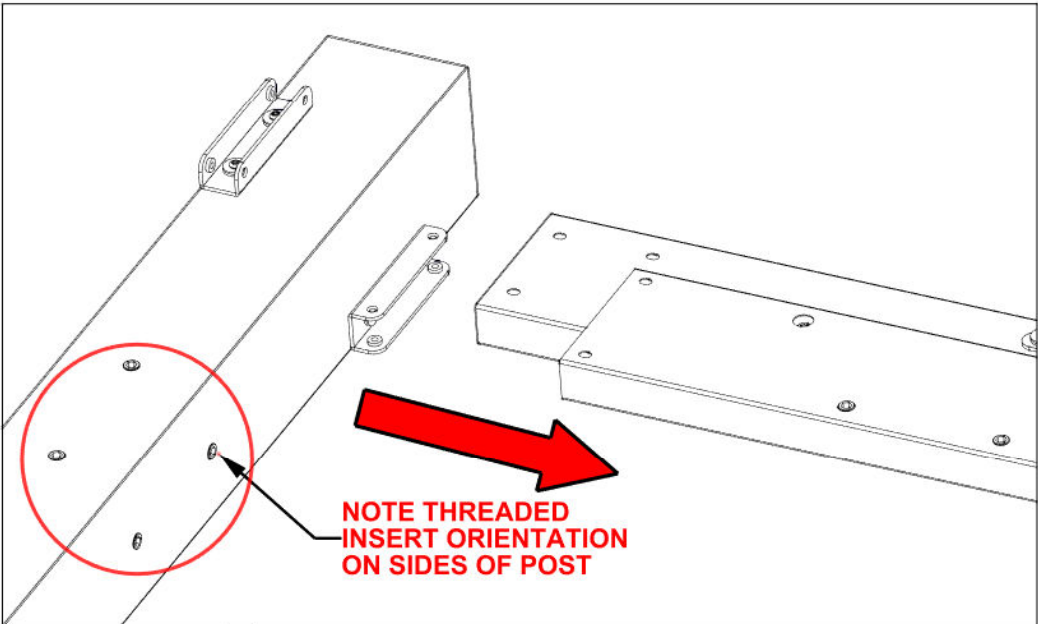

STEP 16B - FRAME ASSEMBLY

Qty	PartNo	Description
2	H101202	TORX PAN HEAD 1/4-20x3/4 ASSY

1202 (x2)
TORX PAN HEAD 1/4-20x3/4 ASSY

HAND TIGHTEN ONLY

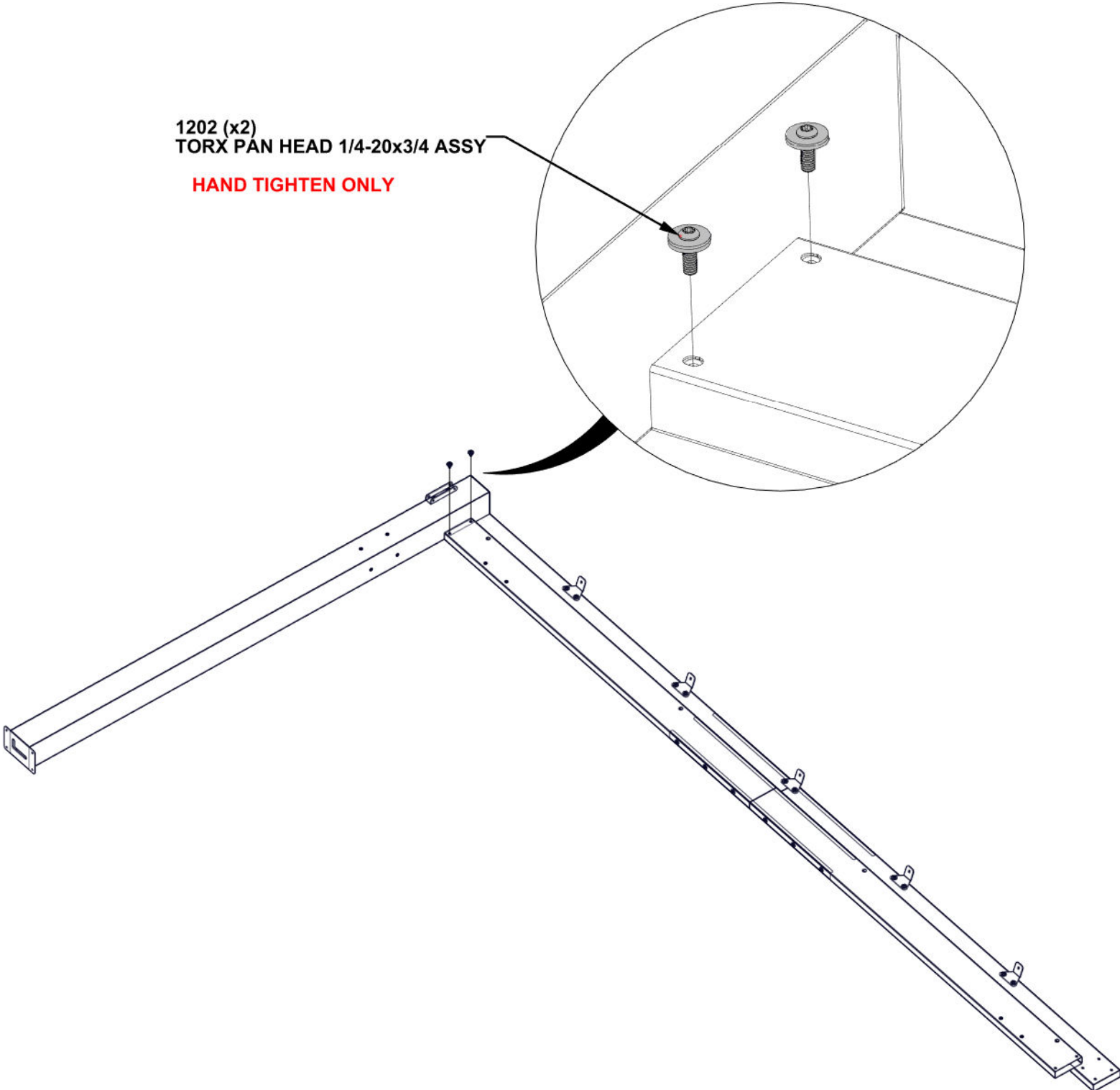

STEP 16C - FRAME ASSEMBLY

Qty	PartNo	Description
4	H101202	TORX PAN HEAD 1/4-20x3/4 ASSY



C02 CORBEL ASSEMBLY - A4M03526
(x1) 21 13/16"x5 1/4"x2 3/4" (70x134x553.5)

- ATTACH CORBEL TO BEAM AND POST.
- SQUARE AS NEEDED BEFORE TIGHTENING ALL HARDWARE FROM PREVIOUS STEPS.

1202 (x4)
TORX PAN HEAD 1/4-20x3/4 ASSY

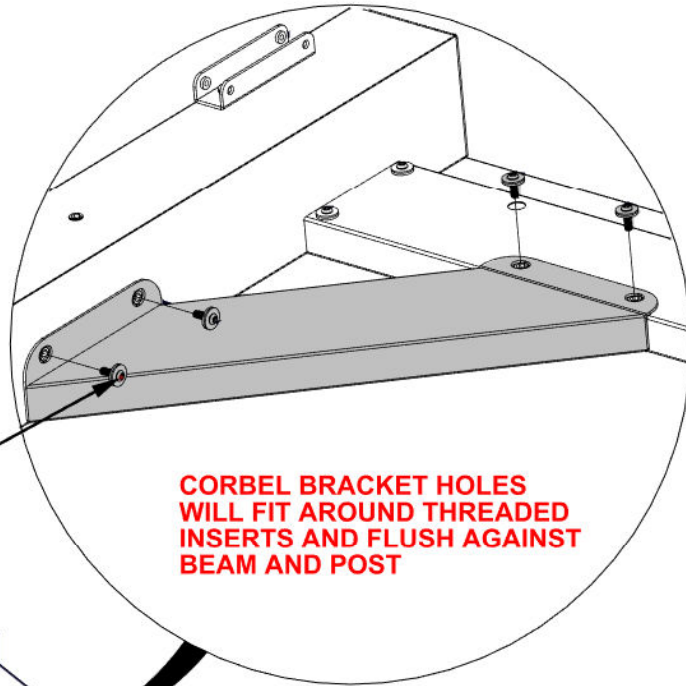

**CORBEL BRACKET HOLES
WILL FIT AROUND THREADED
INSERTS AND FLUSH AGAINST
BEAM AND POST**

C02 (x1)
CORBEL
ASSEMBLY

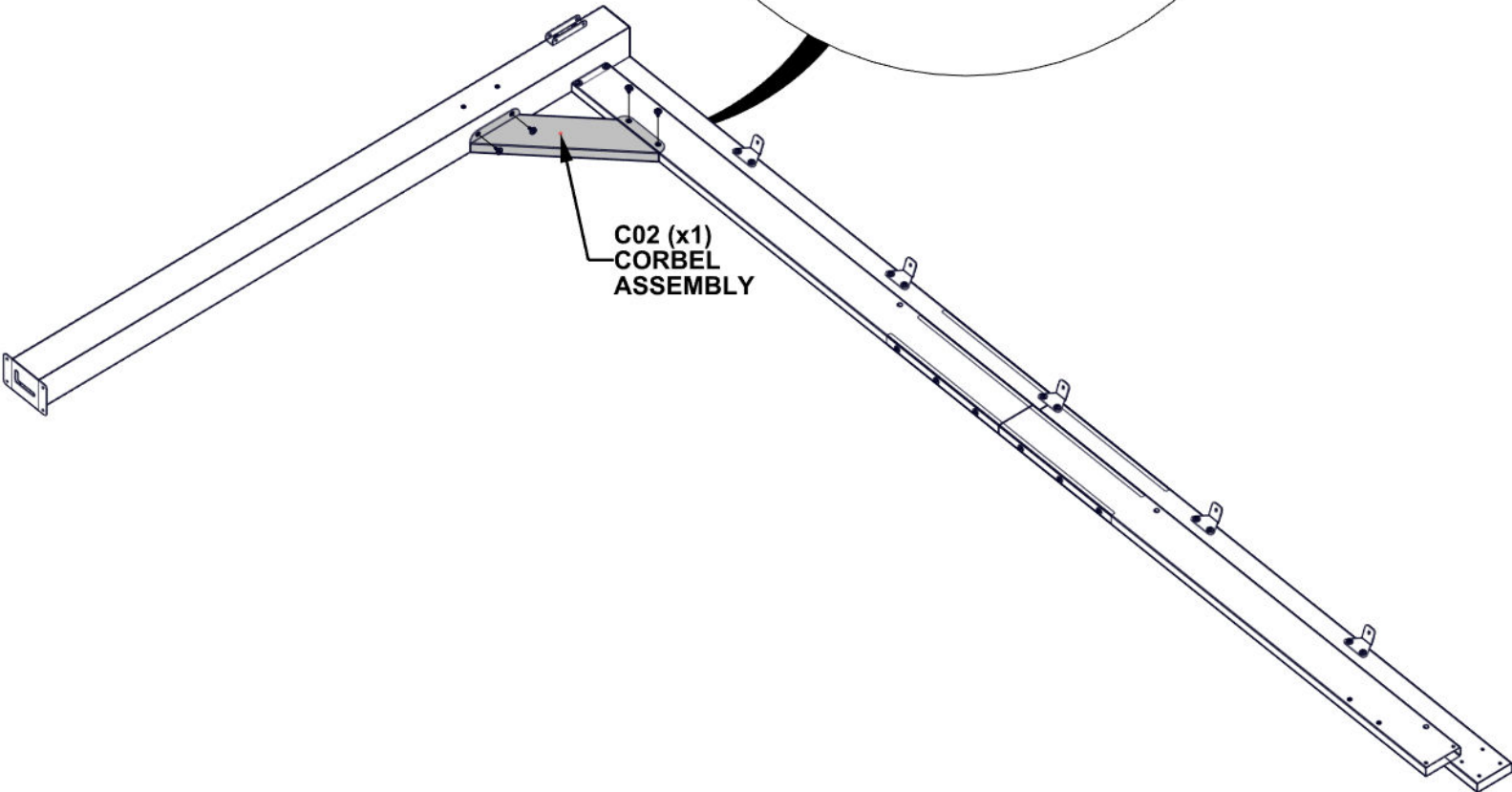

STEP 17A - FRAME ASSEMBLY

- WITH AT LEAST TWO OTHER PEOPLE, ATTACH BEAM AND POST ASSEMBLIES BY SLIDING INTO PLACE.

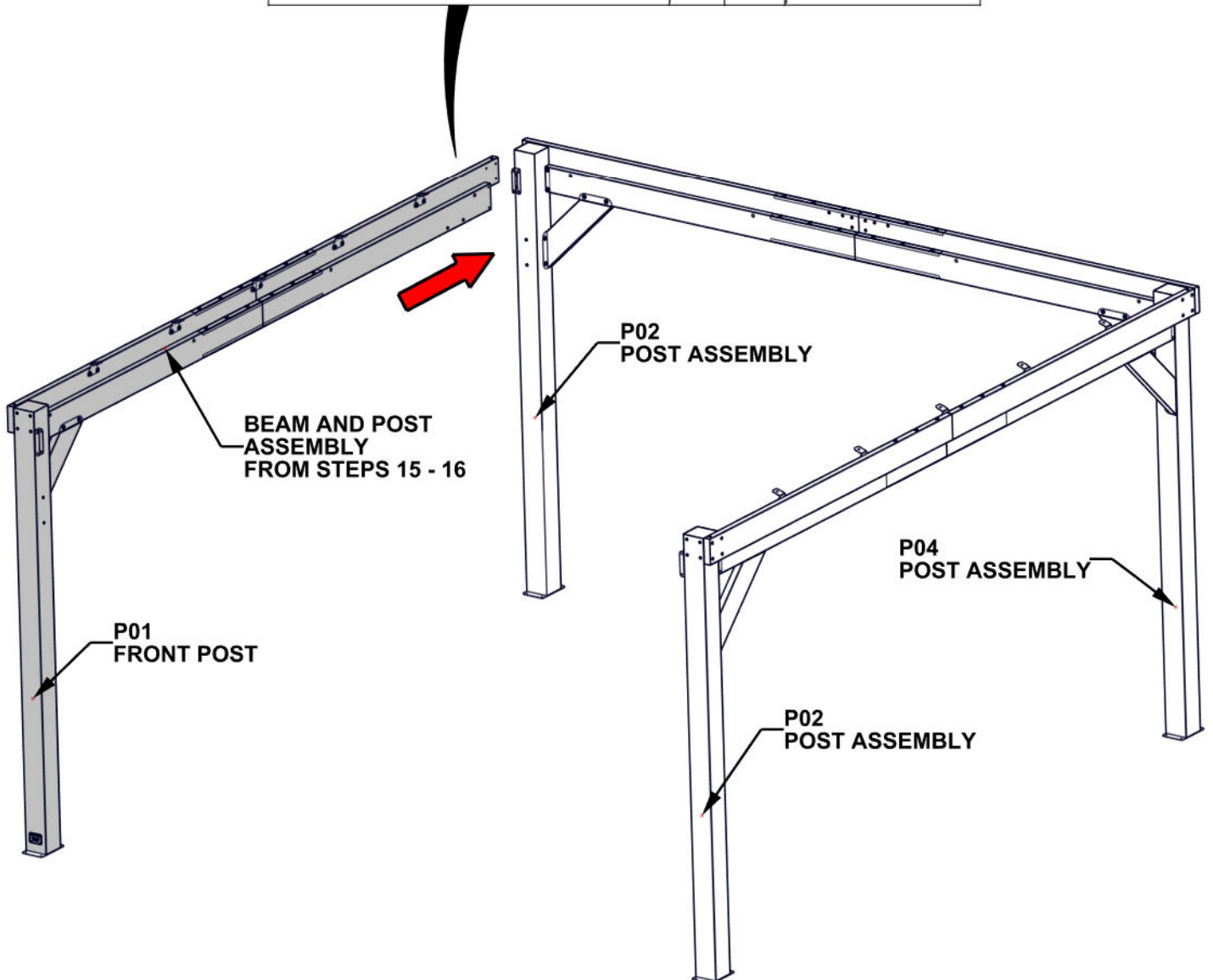
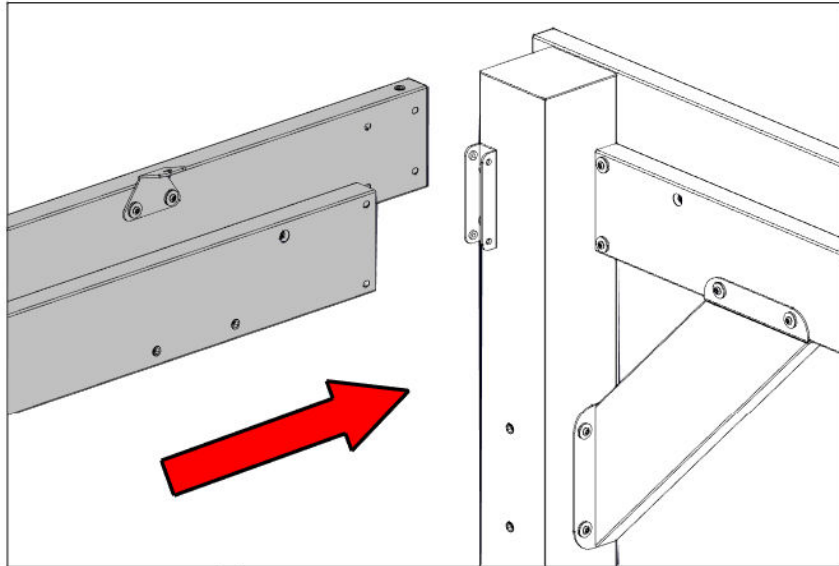

STEP 17B - FRAME ASSEMBLY

Qty	PartNo	Description
4	H101103	TORX SOCKET SCREW 1/4-20

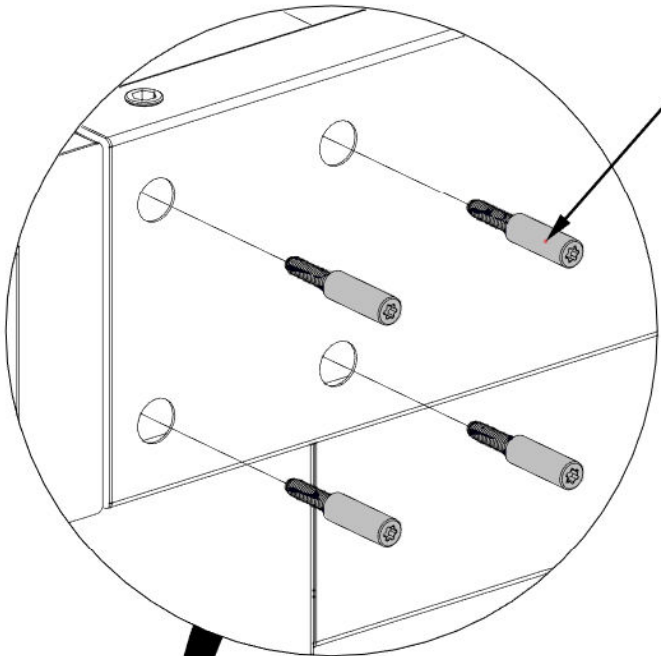

1103 (x4)
TORX SOCKET SCREW 1/4-20
HAND TIGHTEN ONLY

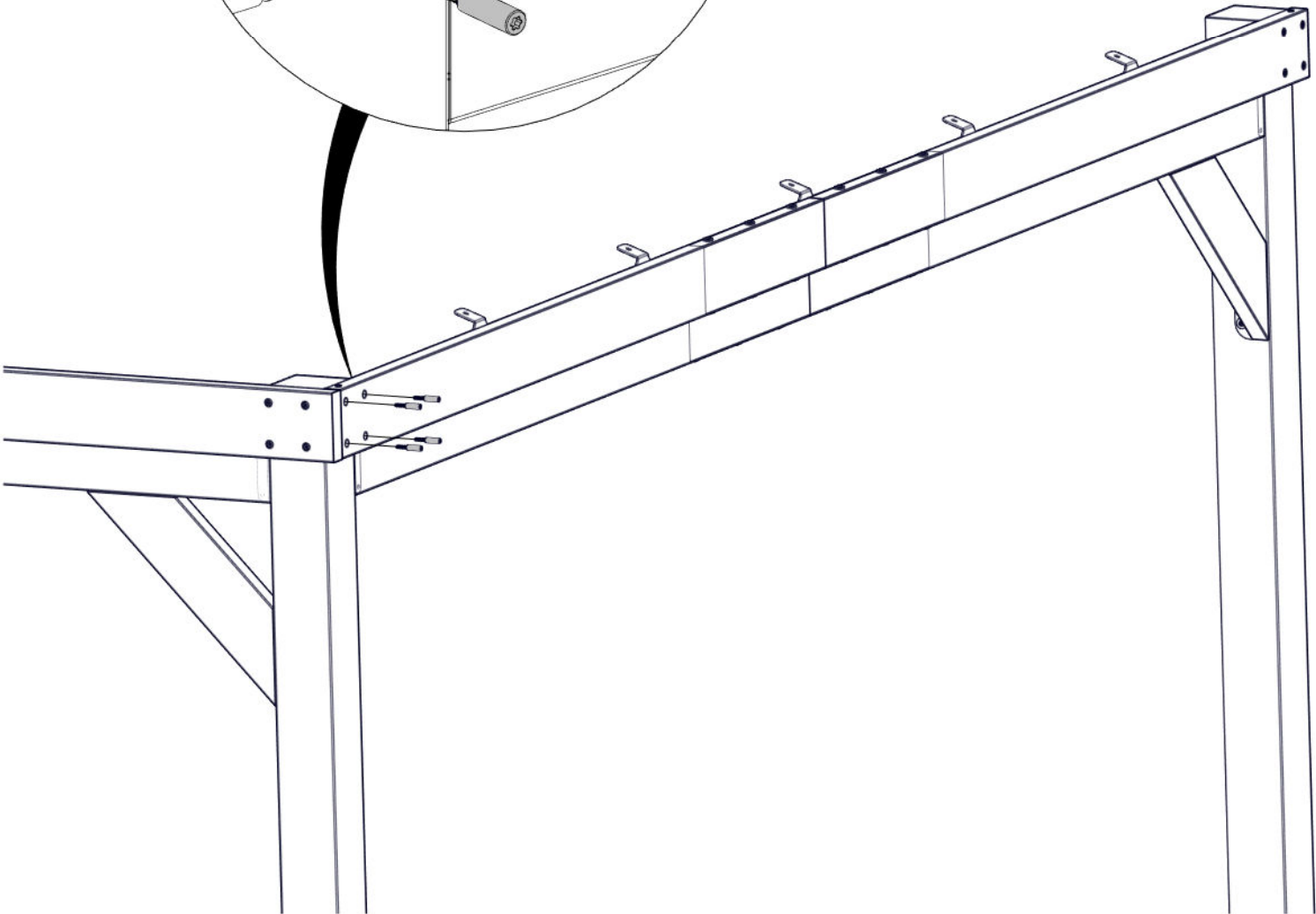

STEP 17C - FRAME ASSEMBLY

Qty	PartNo	Description
4	H101103	TORX SOCKET SCREW 1/4-20

1103 (x4)
TORX SOCKET SCREW 1/4-20
HAND TIGHTEN ONLY

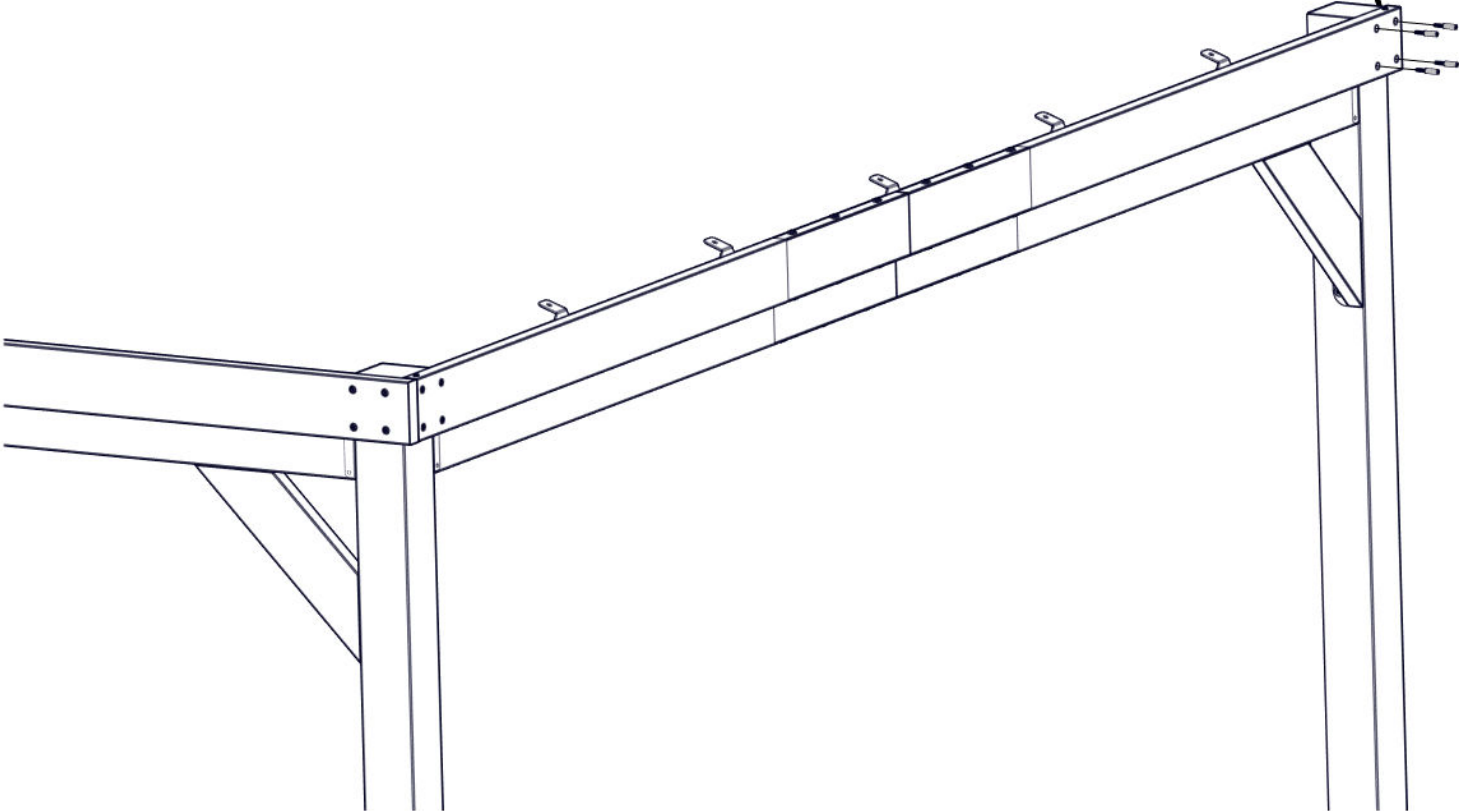
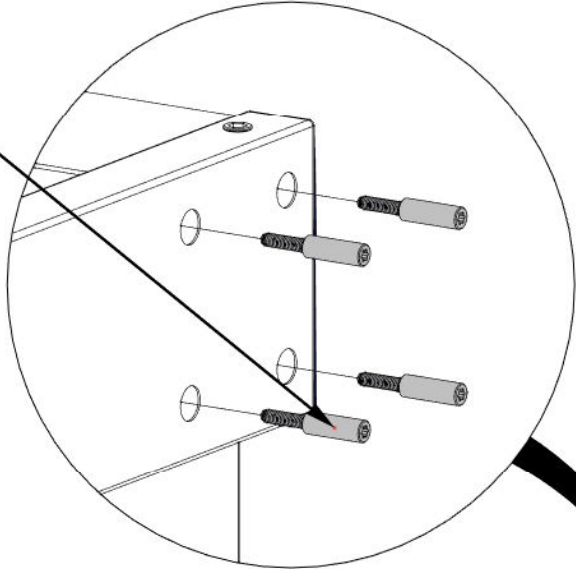

STEP 17D - FRAME ASSEMBLY

Qty	PartNo	Description
2	H101202	TORX PAN HEAD 1/4-20x3/4 ASSY

- SQUARE BEAM ASSEMBLY TO POST

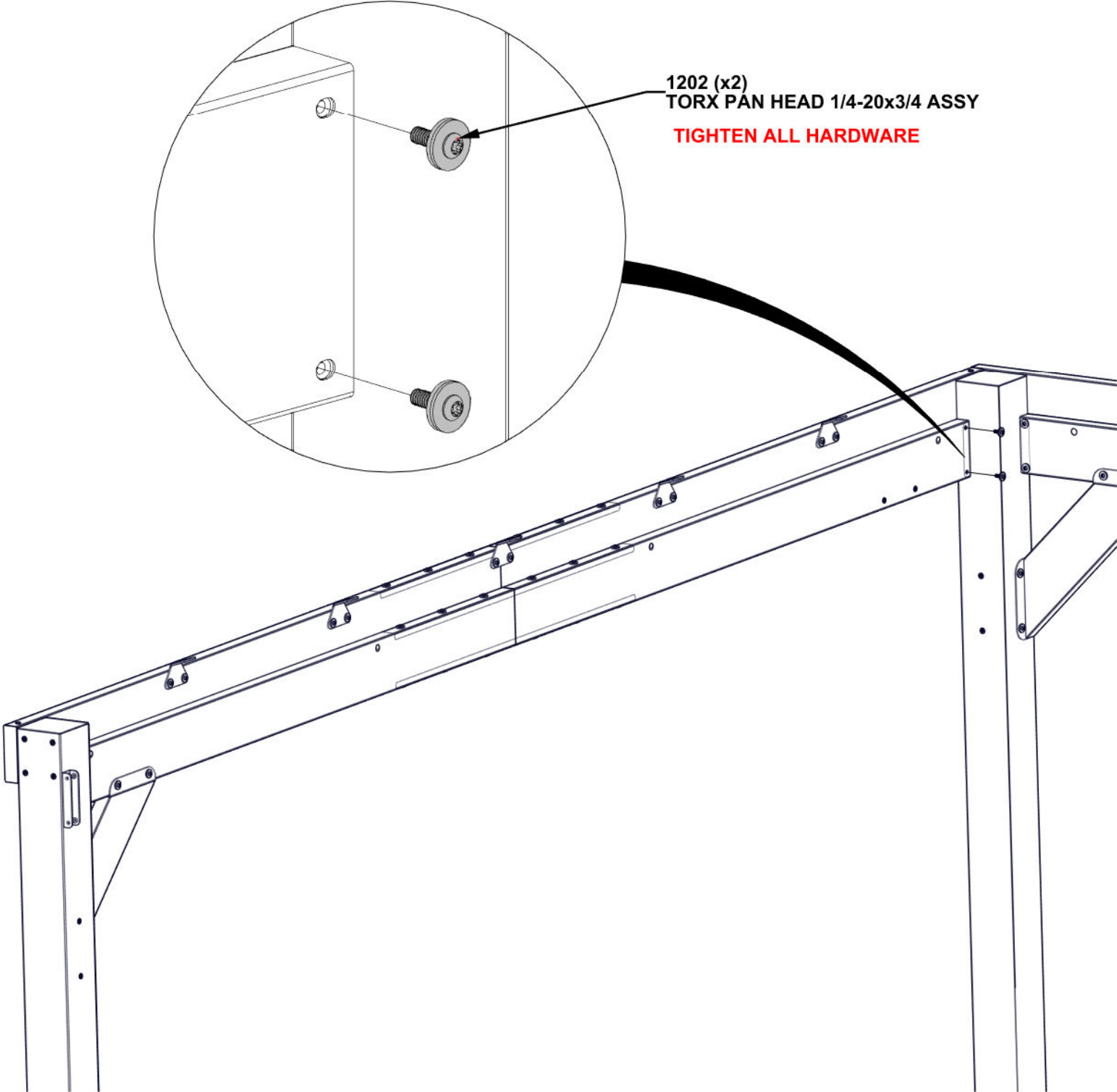

STEP 18 - FRAME ASSEMBLY

Qty	PartNo	Description
4	H101202	TORX PAN HEAD 1/4-20x3/4 ASSY



C01 CORBEL ASSEMBLY - A4M03525
(x1) 21 13/16"x5 1/4"x2 3/4" (70x134x553.5)

- ATTACH CORBEL TO BEAM AND POST.
- **SQUARE AS NEEDED BEFORE TIGHTENING ALL HARDWARE FROM PREVIOUS STEPS.**

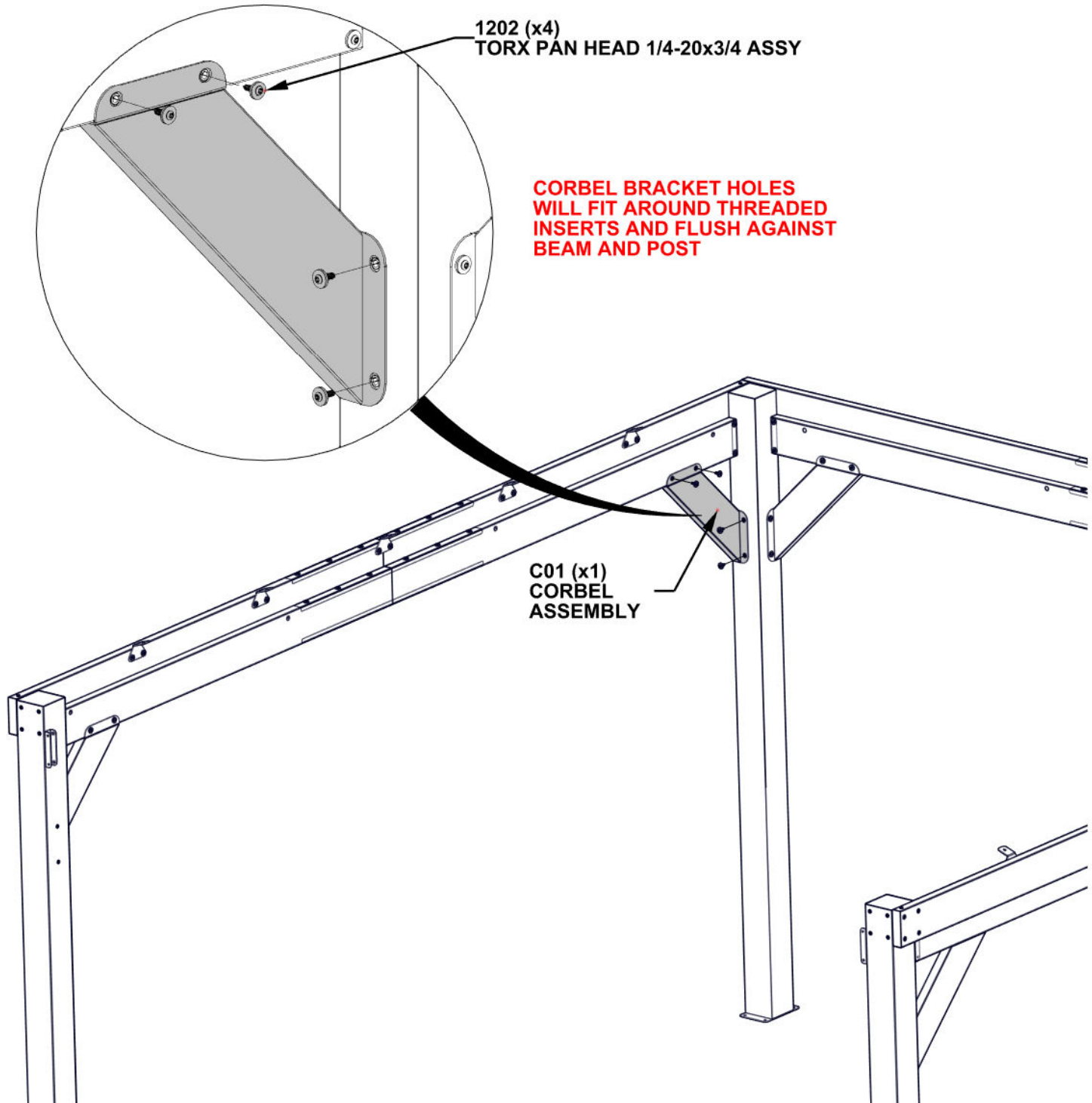

STEP 19A - FRAME ASSEMBLY

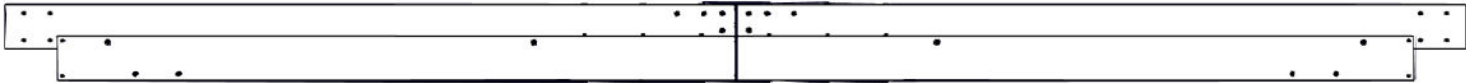

BEAM ASSEMBLY FROM STEPS 1 - 5

- WITH AT LEAST TWO OTHER PEOPLE, SPREAD FRONT POST APART ENOUGH TO ATTACH BEAM ASSEMBLY INTO BEAM BRACKETS.

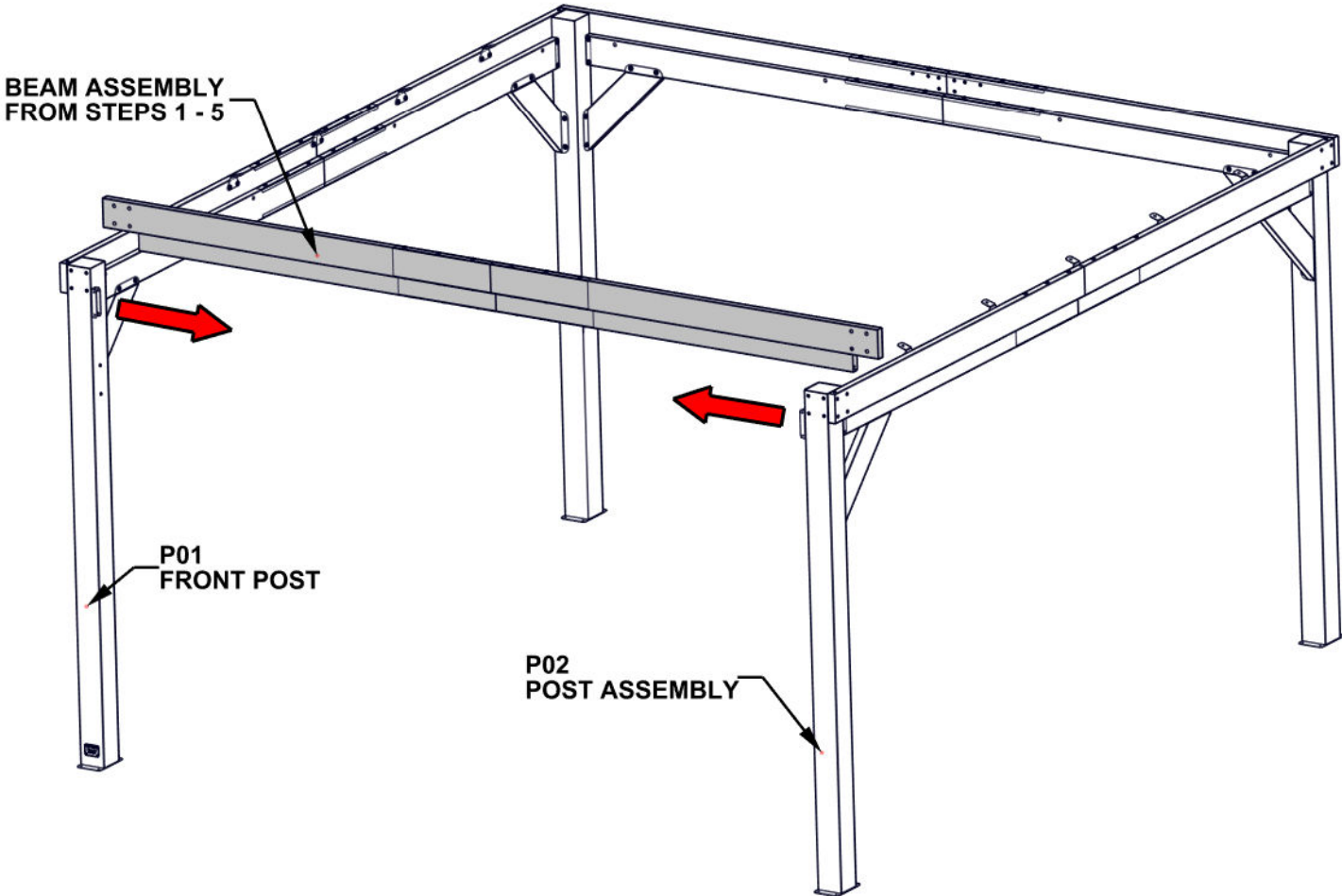

STEP 19B - FRAME ASSEMBLY

Qty	PartNo	Description
8	H101103	TORX SOCKET SCREW 1/4-20

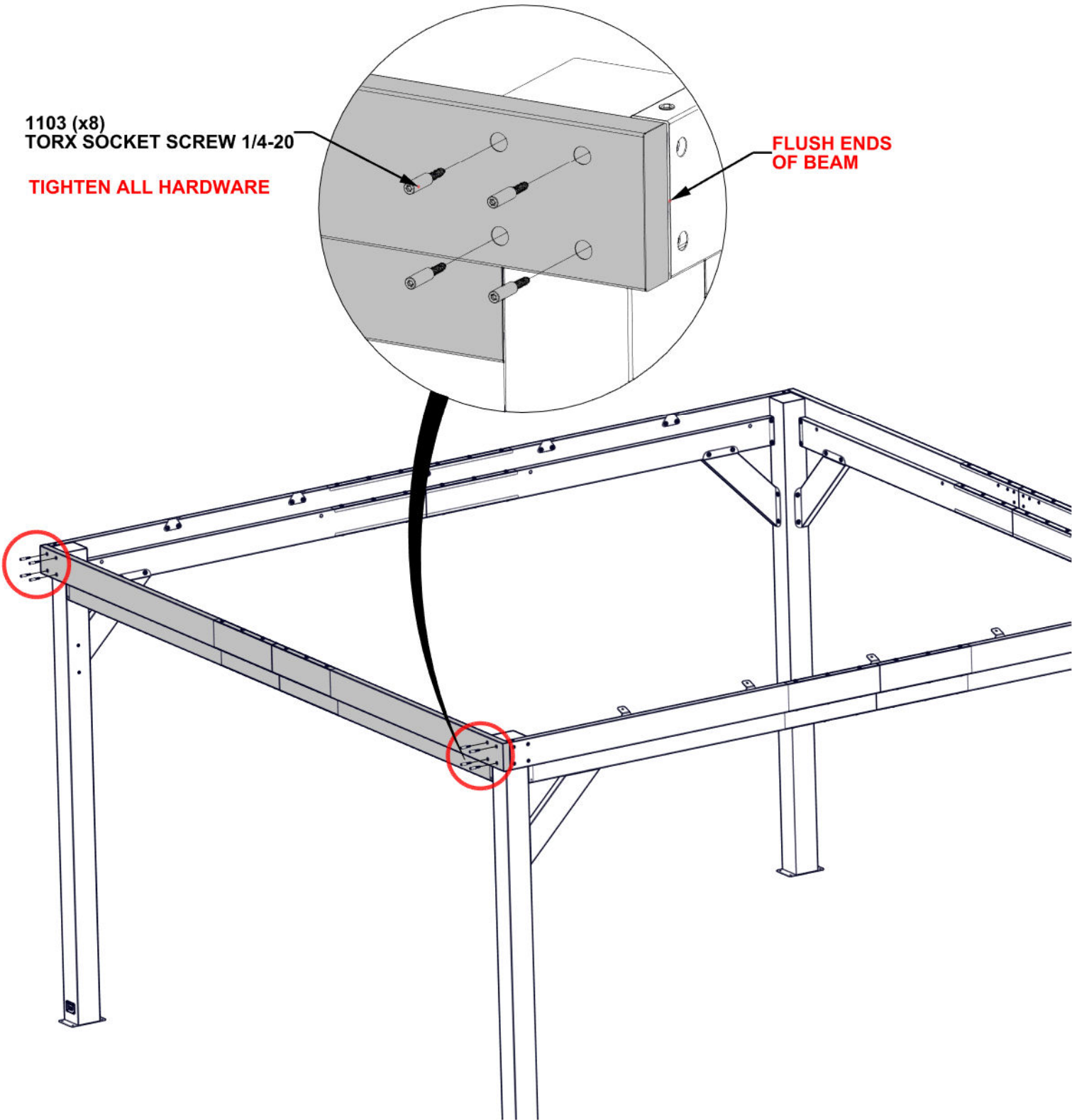

STEP 19C - FRAME ASSEMBLY

Qty	PartNo	Description
4	H101202	TORX PAN HEAD 1/4-20x3/4 ASSY

- SQUARE BEAM ASSEMBLY TO POST

1202 (x4)
TORX PAN HEAD 1/4-20x3/4 ASSY

TIGHTEN ALL HARDWARE

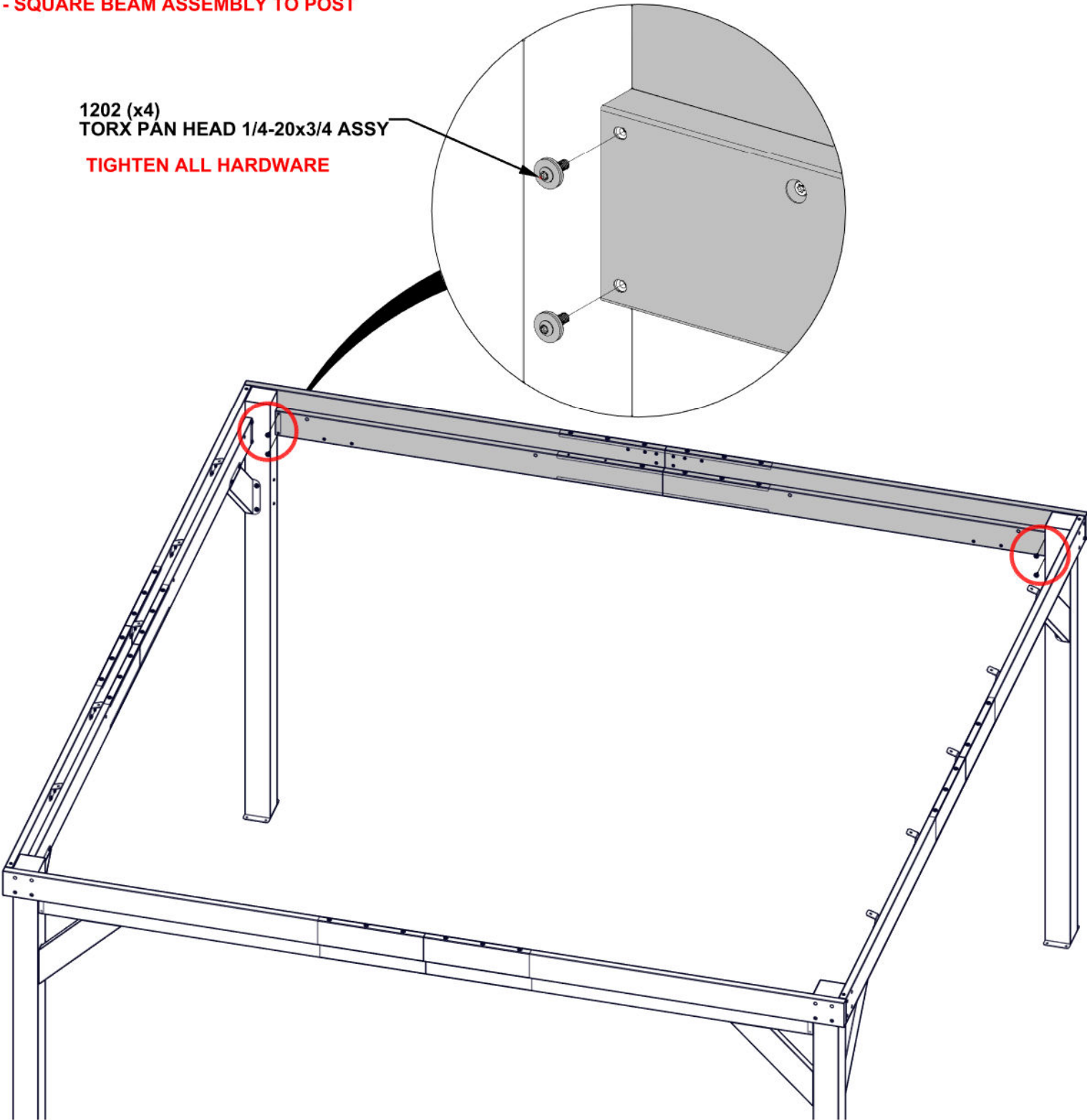

STEP 20 - FRAME ASSEMBLY

Qty	PartNo	Description
8	H101202	TORX PAN HEAD 1/4-20x3/4 ASSY



C01 CORBEL ASSEMBLY - A4M03525
(x1) 21 13/16"x5 1/4"x2 3/4" (70x134x553.5)



C02 CORBEL ASSEMBLY - A4M03526
(x1) 21 13/16"x5 1/4"x2 3/4" (70x134x553.5)

- ATTACH CORBELS TO BEAM AND POST.

- SQUARE AS NEEDED BEFORE TIGHTENING ALL HARDWARE FROM PREVIOUS STEPS.

1202 (x8)
TORX PAN HEAD 1/4-20x3/4 ASSY

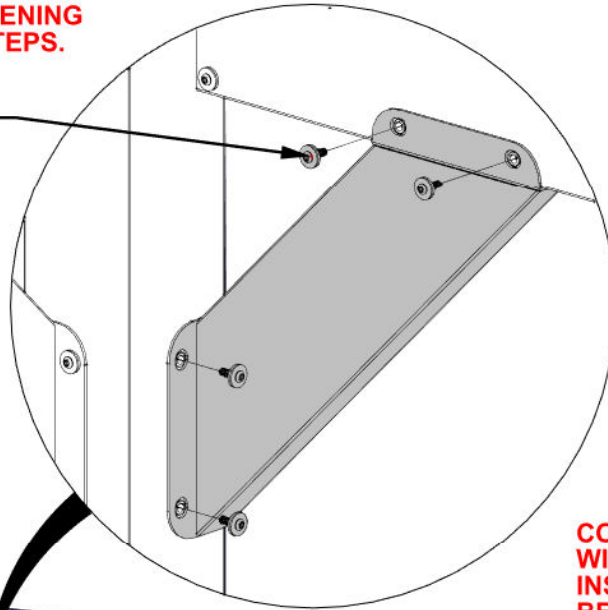

CORBEL BRACKET HOLES WILL FIT AROUND THREADED INSERTS AND FLUSH AGAINST BEAM AND POST

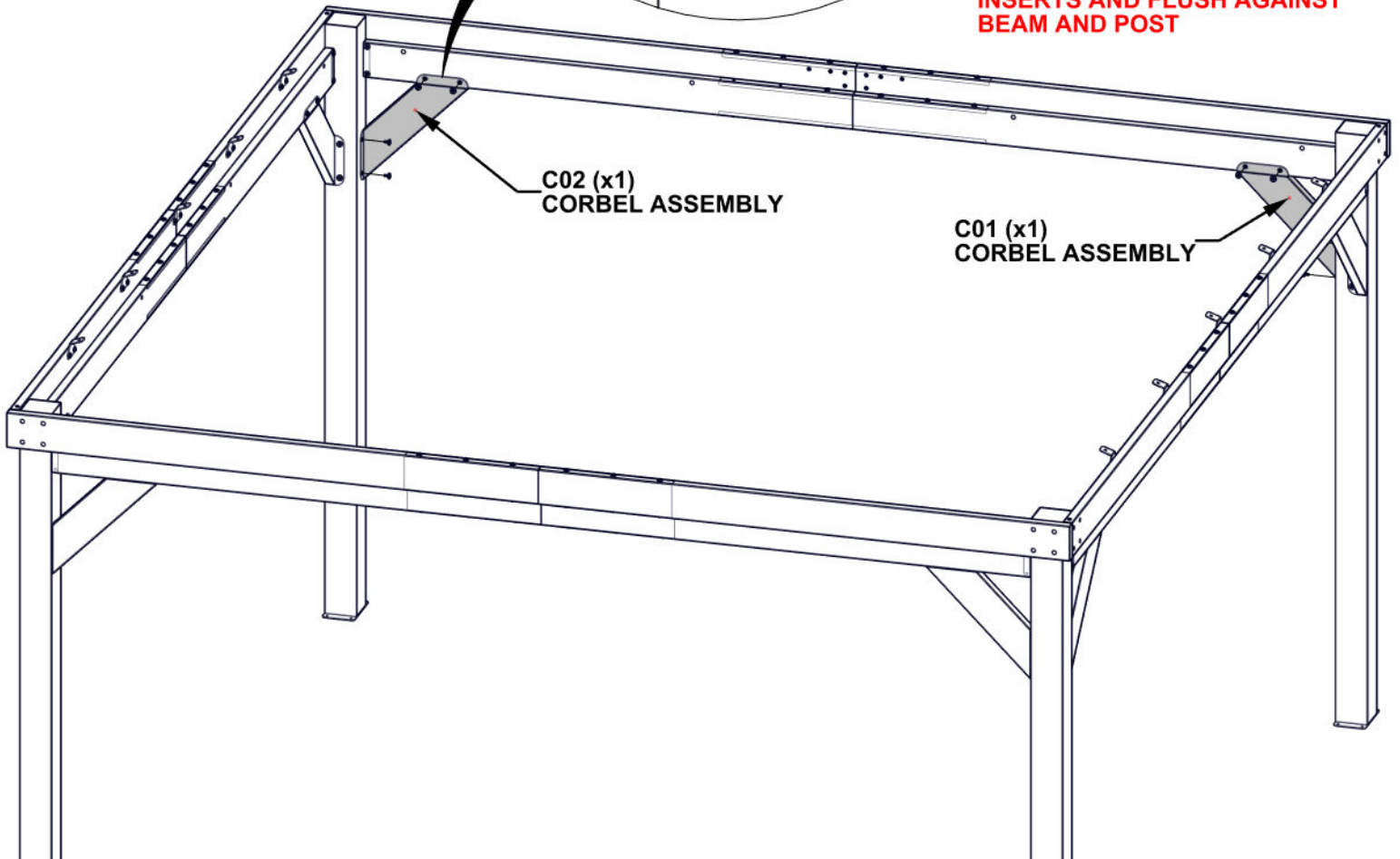

STEP 21 - SQUARE STRUCTURE

- CRITICAL:**
- SQUARE UNIT BEFORE PROCEEDING TO NEXT STEPS.
 - THE BELOW DIMENSIONS ARE CRITICAL TO THE FINAL ASSEMBLY.
 - MEASUREMENTS SHOULD BE WITHIN +/- 1/4" (6mm).
 - MEASUREMENTS OUTSIDE OF TOLERANCE WILL LEAD TO ISSUES ON FUTURE ASSEMBLY STEPS.
 - TIGHTEN ALL HARDWARE FROM PREVIOUS STEPS.

MEASUREMENTS TAKEN FROM INSIDE CORNER TO INSIDE CORNER OF POST

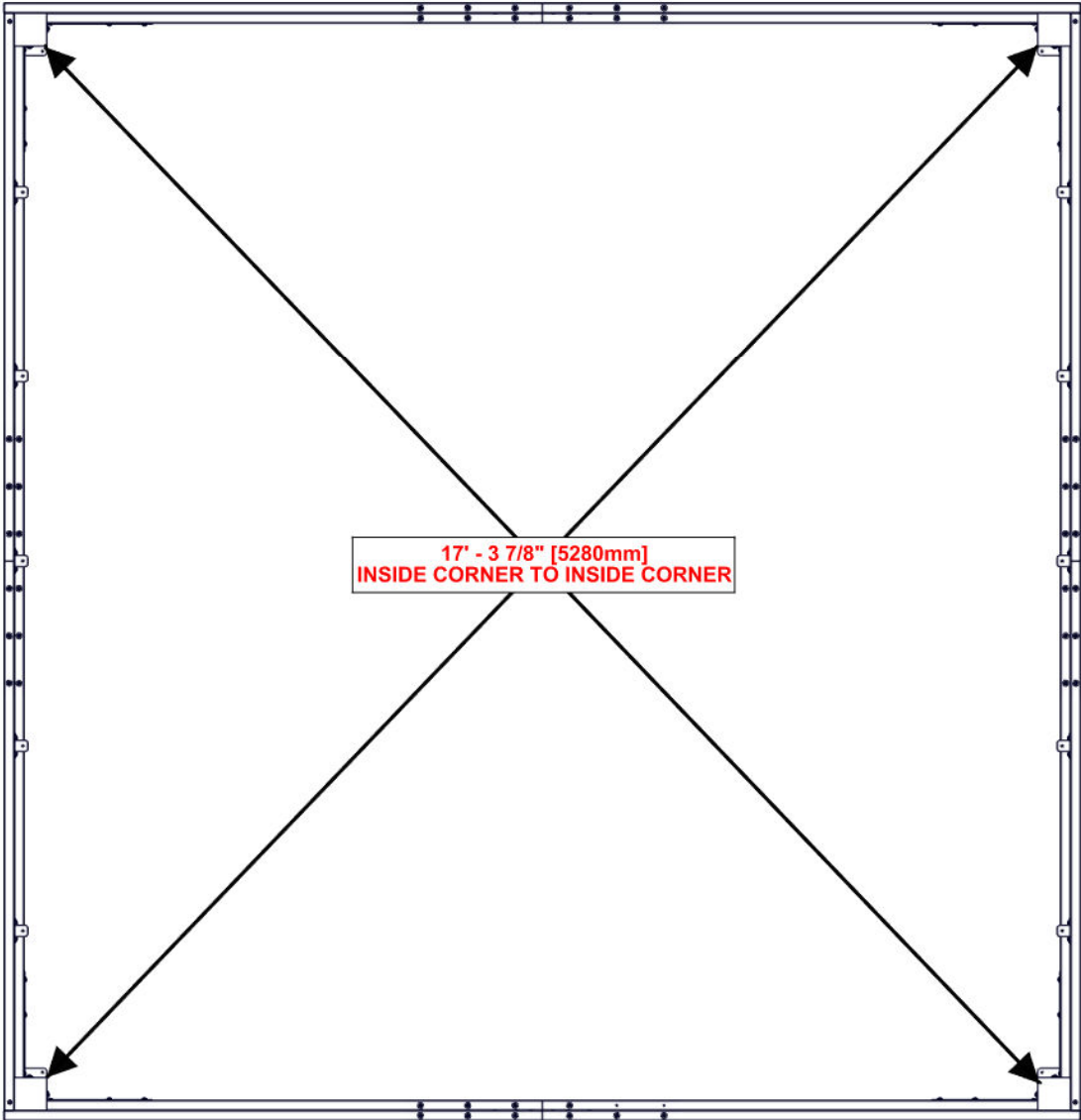

STEP 22 - GABLE ASSEMBLY

Qty	PartNo	Description
8	H101103	TORX SOCKET SCREW 1/4-20



B07 GABLE ARM ASSEMBLY - A4M03513
(x2) 29 3/16"x5 1/4"x1 7/16" (36x134x741)

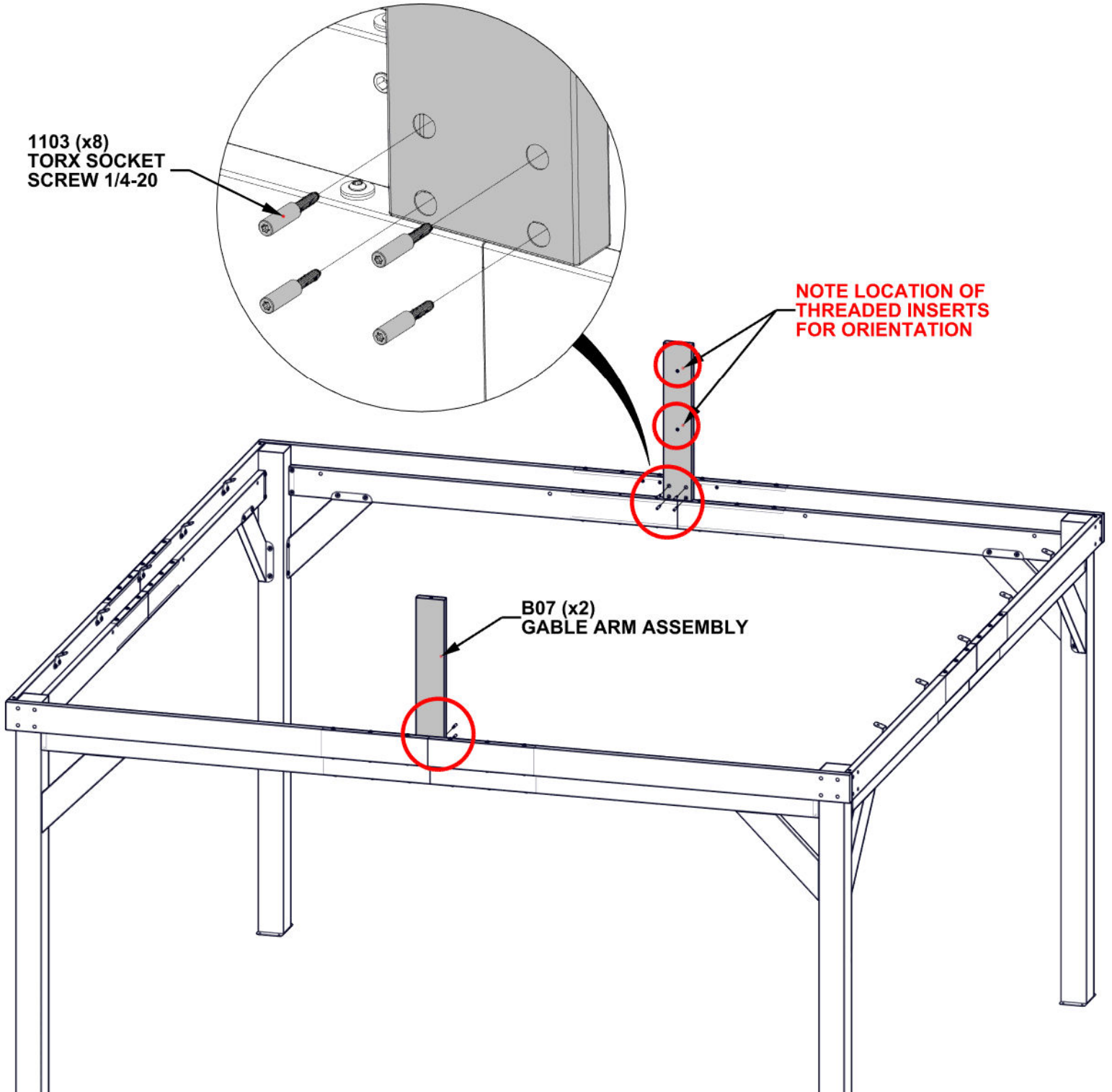

STEP 23A - RIDGE BEAM ASSEMBLY

Qty	PartNo	Description
6	H101202	TORX PAN HEAD 1/4-20x3/4 ASSY



B11 RIDGE BEAM ASSEMBLY - A4M04418
 (x1) 92 1/4"x5 1/4"x1 7/16" (36x134x2343.50)



J2 SPLICE BRACKET - A4M01270
 (x1) 1 1/4"x5 1/8"x15 3/4" (33x131x400)

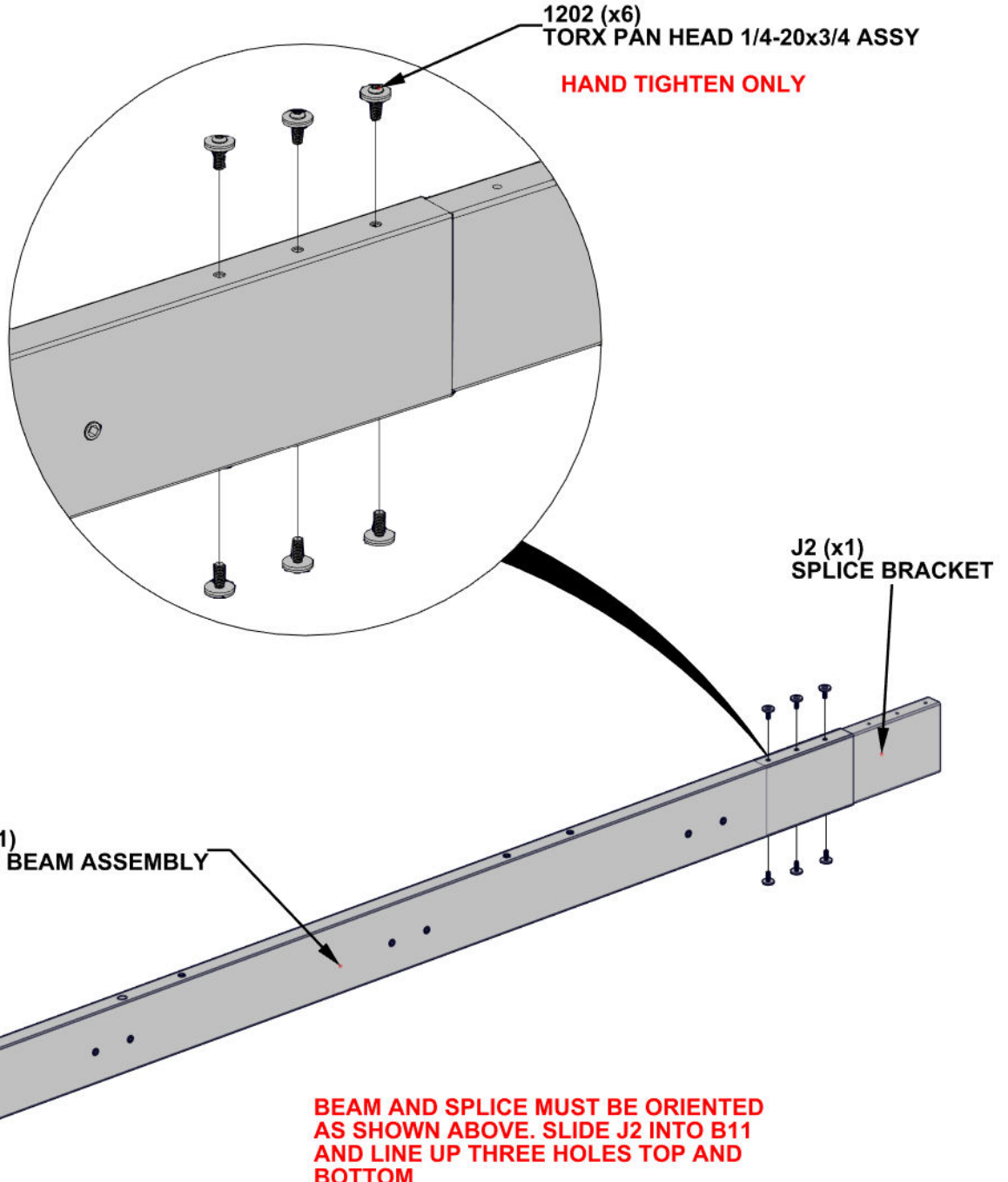

STEP 23B - RIDGE BEAM ASSEMBLY

Qty	PartNo	Description
6	H101202	TORX PAN HEAD 1/4-20x3/4 ASSY



B10 RIDGE BEAM ASSEMBLY - A4M04417
 (x1) 100 15/16"x5 1/4"x1 7/16" (36x134x2564.28)

- SLIDE B10 ONTO SPLICE BRACKET.
 GENTLY TAP ENDS OF ASSEMBLY WITH
 RUBBER Mallet UNTIL GAP CLOSES.

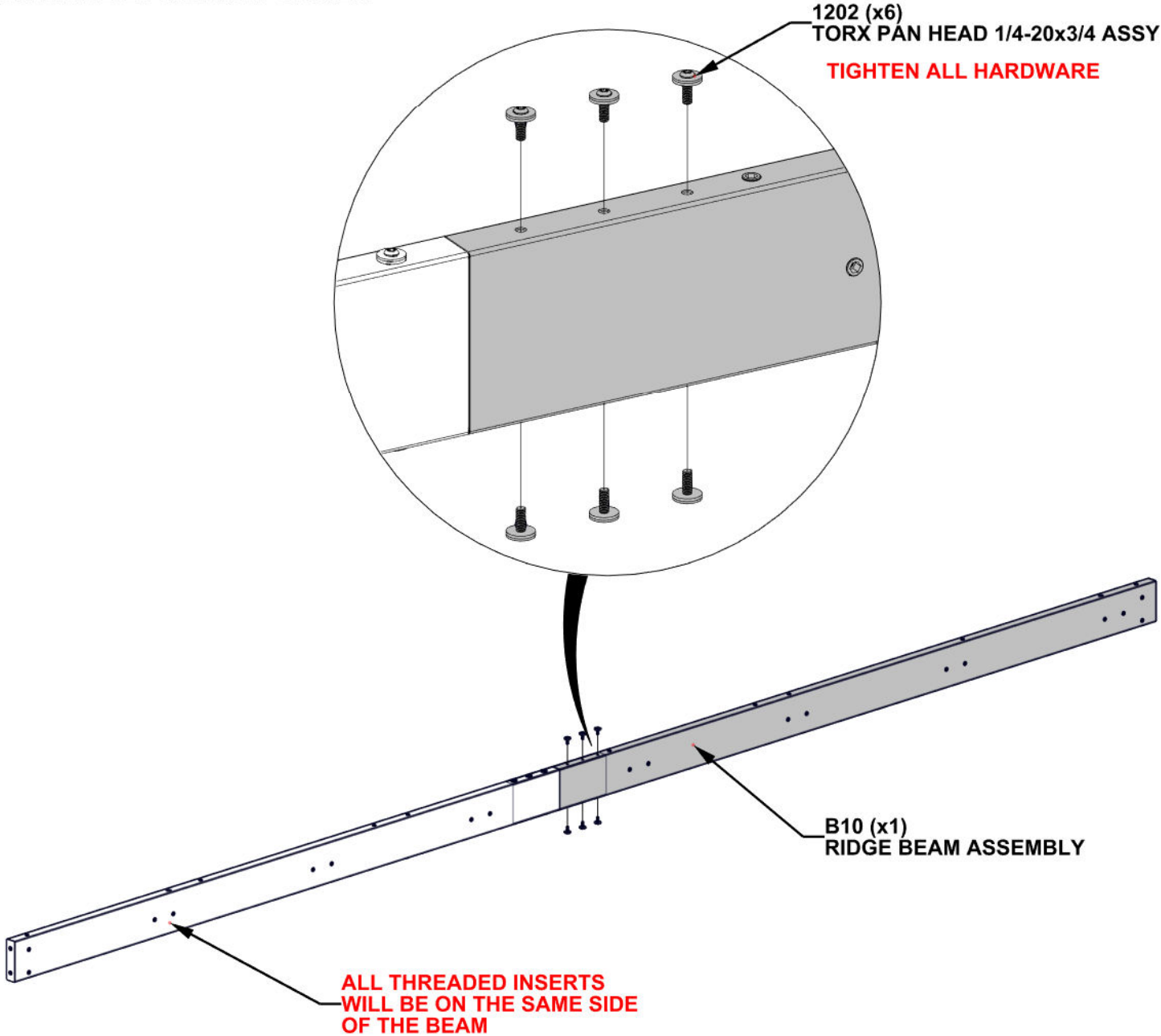

STEP 24A - RIDGE BEAM ASSEMBLY

Qty	PartNo	Description
4	H101202	TORX PAN HEAD 1/4-20x3/4 ASSY

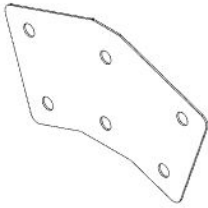

J3 GABLE BRACKET - A4M03805
(x2) 11 1/8"x6 7/16"x1/16" (2x163x282)

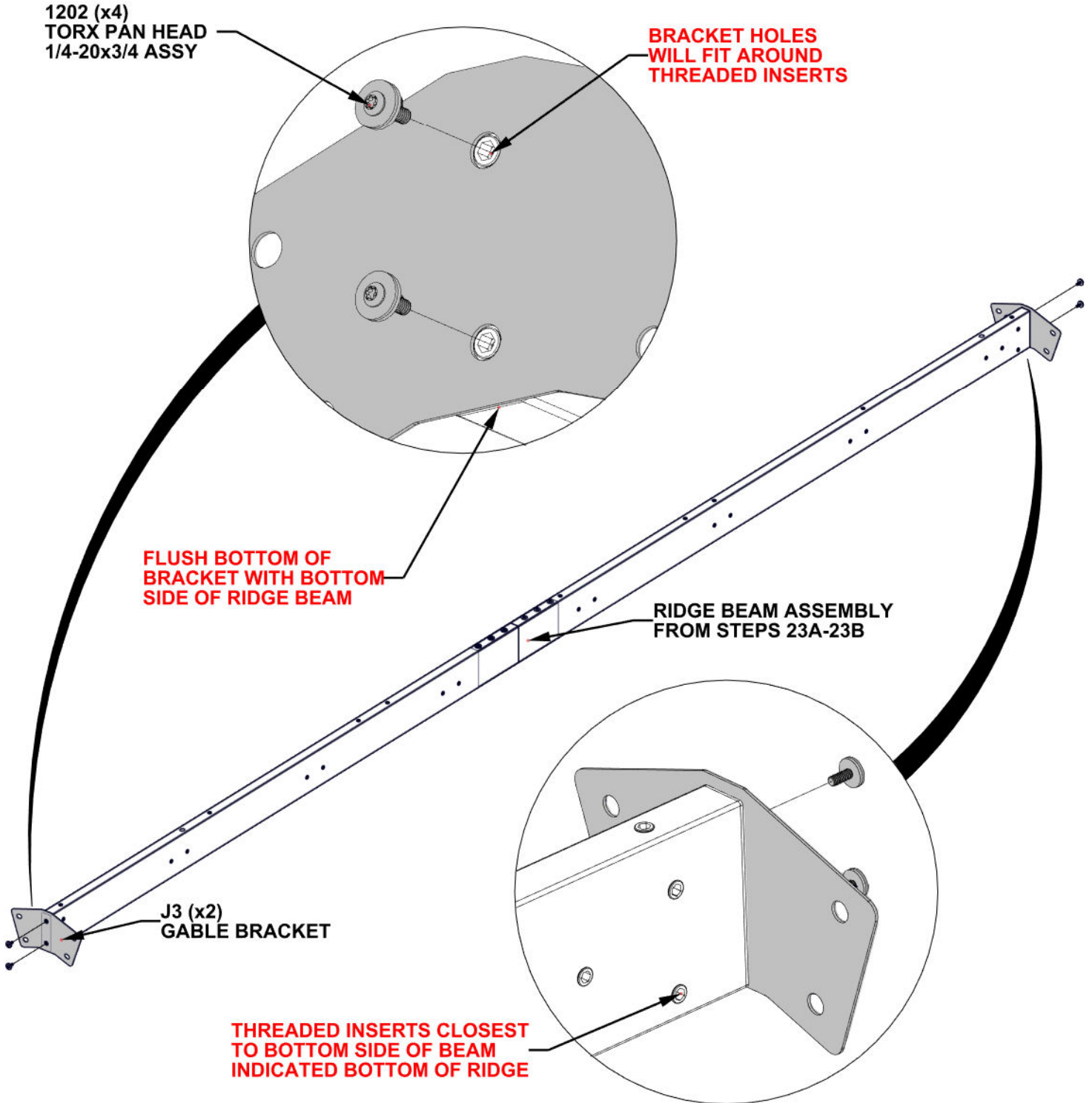

STEP 24B - RIDGE ASSEMBLY

Qty	PartNo	Description
2	H101230	BOLT WH 5/16x6 S.S.

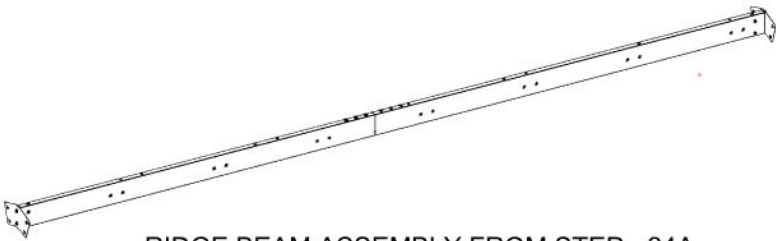

RIDGE BEAM ASSEMBLY FROM STEP - 24A

- WITH AT LEAST TWO PEOPLE, ATTACH RIDGE ASSEMBLY TO GABLE UPRIGHTS.

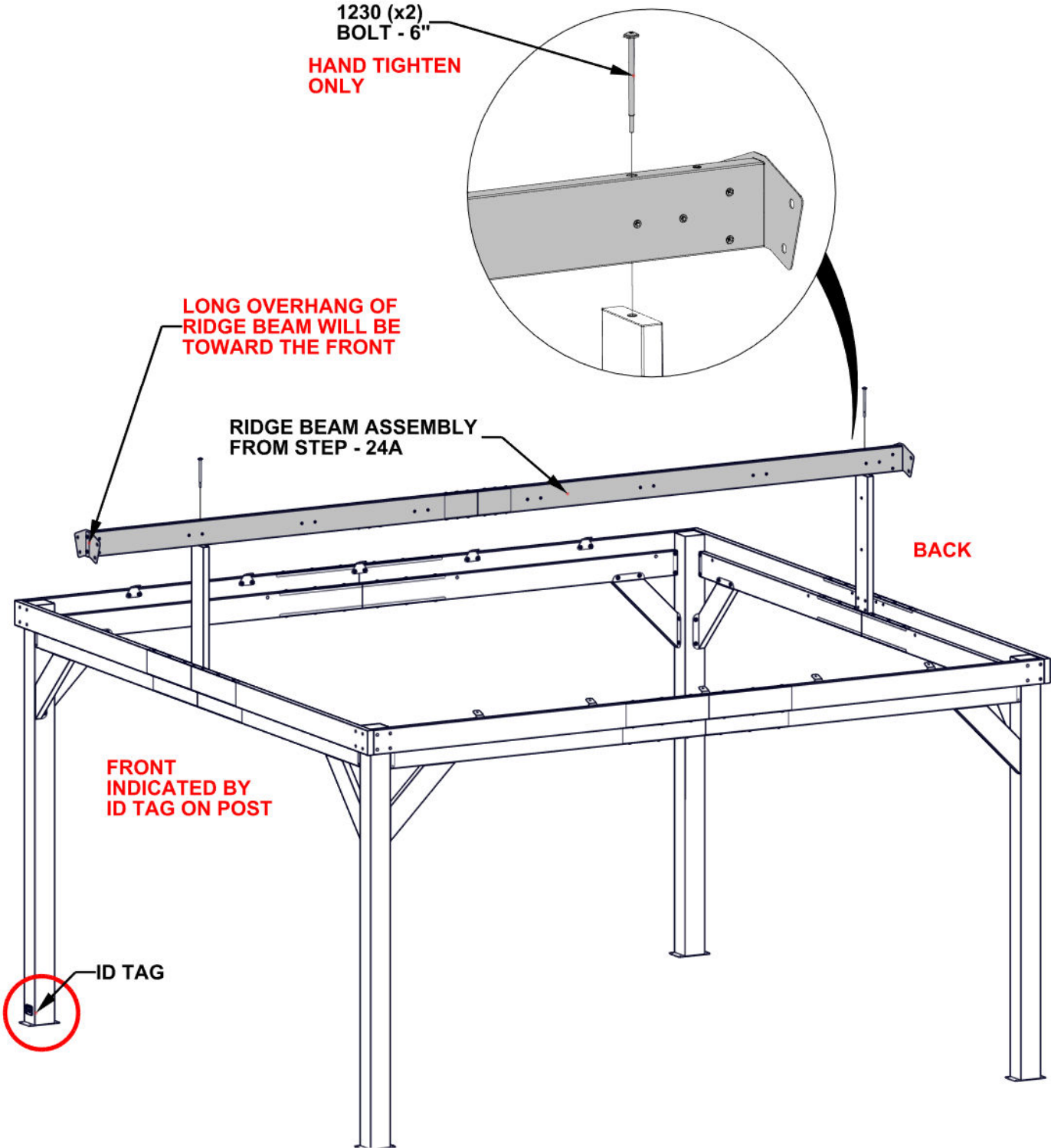

STEP 25 - RIDGE ASSEMBLY

Qty	PartNo	Description
8	H101202	TORX PAN HEAD 1/4-20x3/4 ASSY

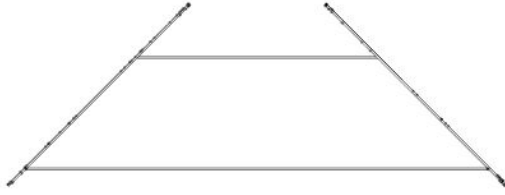

C03 CORBEL ASSEMBLY - A4M03527
(x2) 23 3/8"x12"x1 7/16" (36x304x593)

- IT IS RECOMMENDED TO USE PROVIDED ANGLE DRIVER TO INSTALL HARDWARE IN THIS STEP.
- ATTACH CORBELS TO RIDGE BEAM AND GABLE ARMS.
- **SQUARE AS NEEDED BEFORE TIGHTENING ALL HARDWARE FROM PREVIOUS STEPS.**

1202 (x8)
TORX PAN HEAD 1/4-20x3/4 ASSY

TIGHTEN ALL HARDWARE

CORBEL BRACKET HOLES WILL FIT AROUND THREADED INSERTS AND FLUSH AGAINST RIDGE BEAM AND GABLE

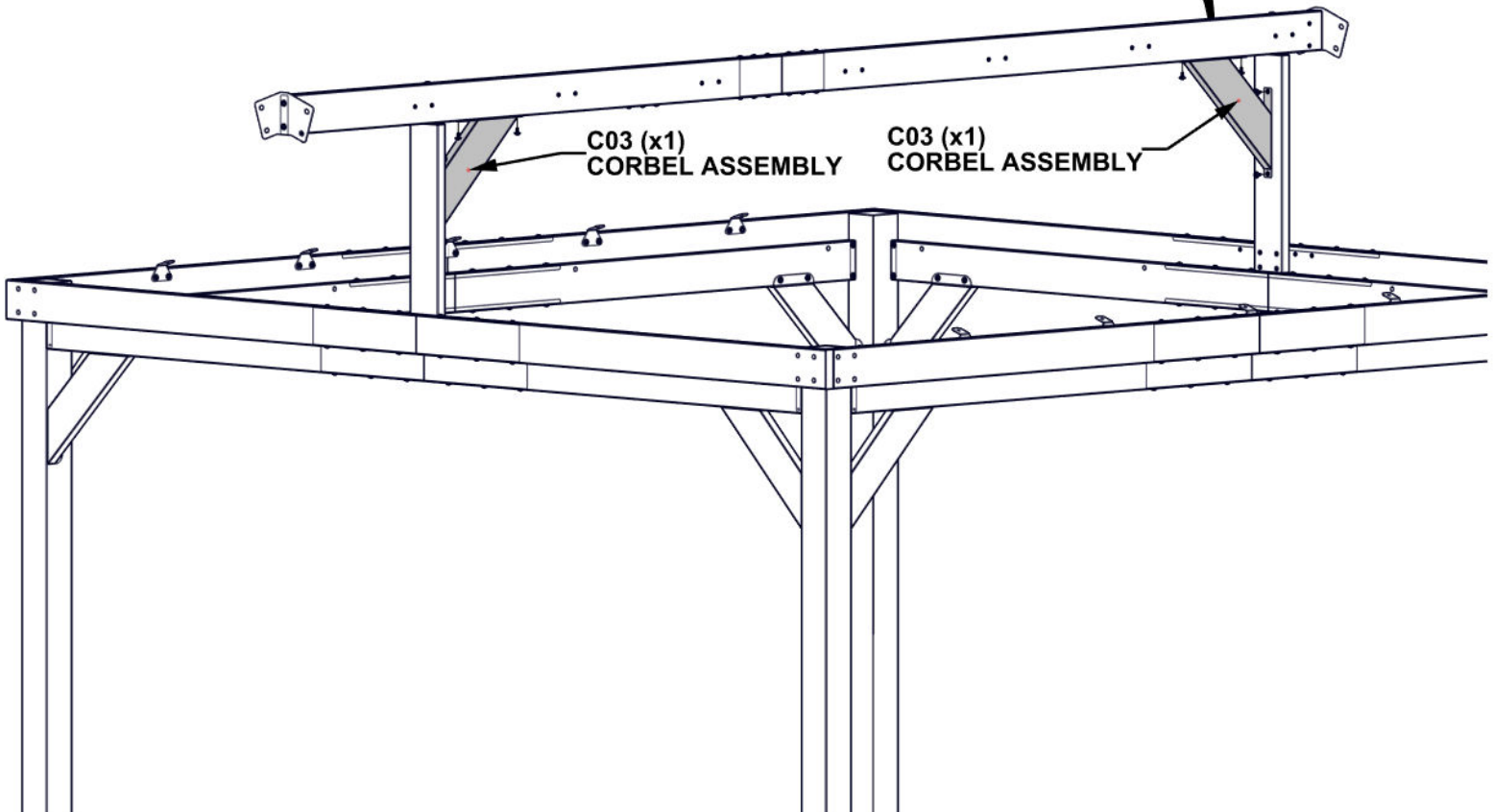
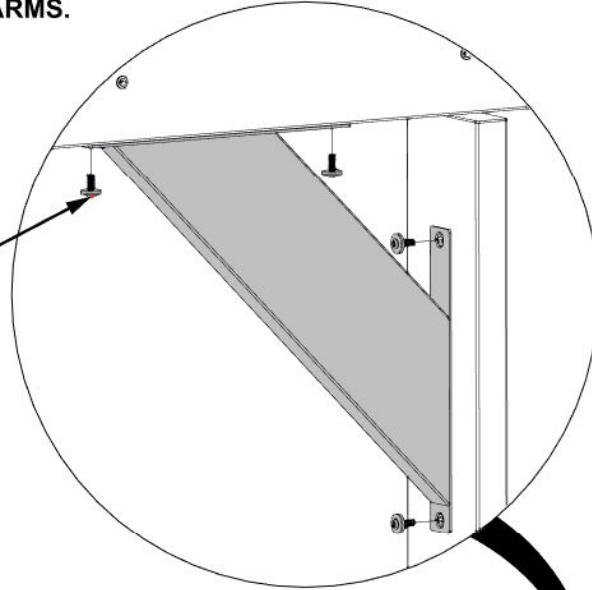

STEP 26A - RIDGE ASSEMBLY

Qty	PartNo	Description
3	H101053	STEEL WASHER 6x20
3	H101054	SEALANT WASHER
3	H101293	TORX PAN HEAD 1/4-20x1 3/8"

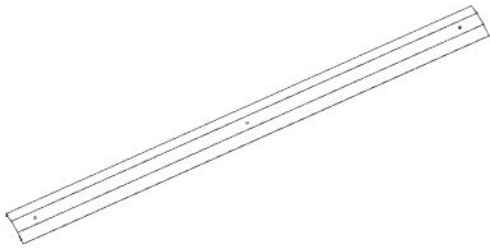

A4M04429 RIDGE CAP
(x1)



J10 SUPPORT RING - A4M03808
(x3) 13/16"x7/16" (11x20x)

- **WARNING: GLOVES ARE RECOMMENDED WHEN HANDLING STEEL ROOF PIECE.**
- REMOVE PROTECTIVE FILM.
- ORIENT RIDGE CAP AS SHOWN BELOW.

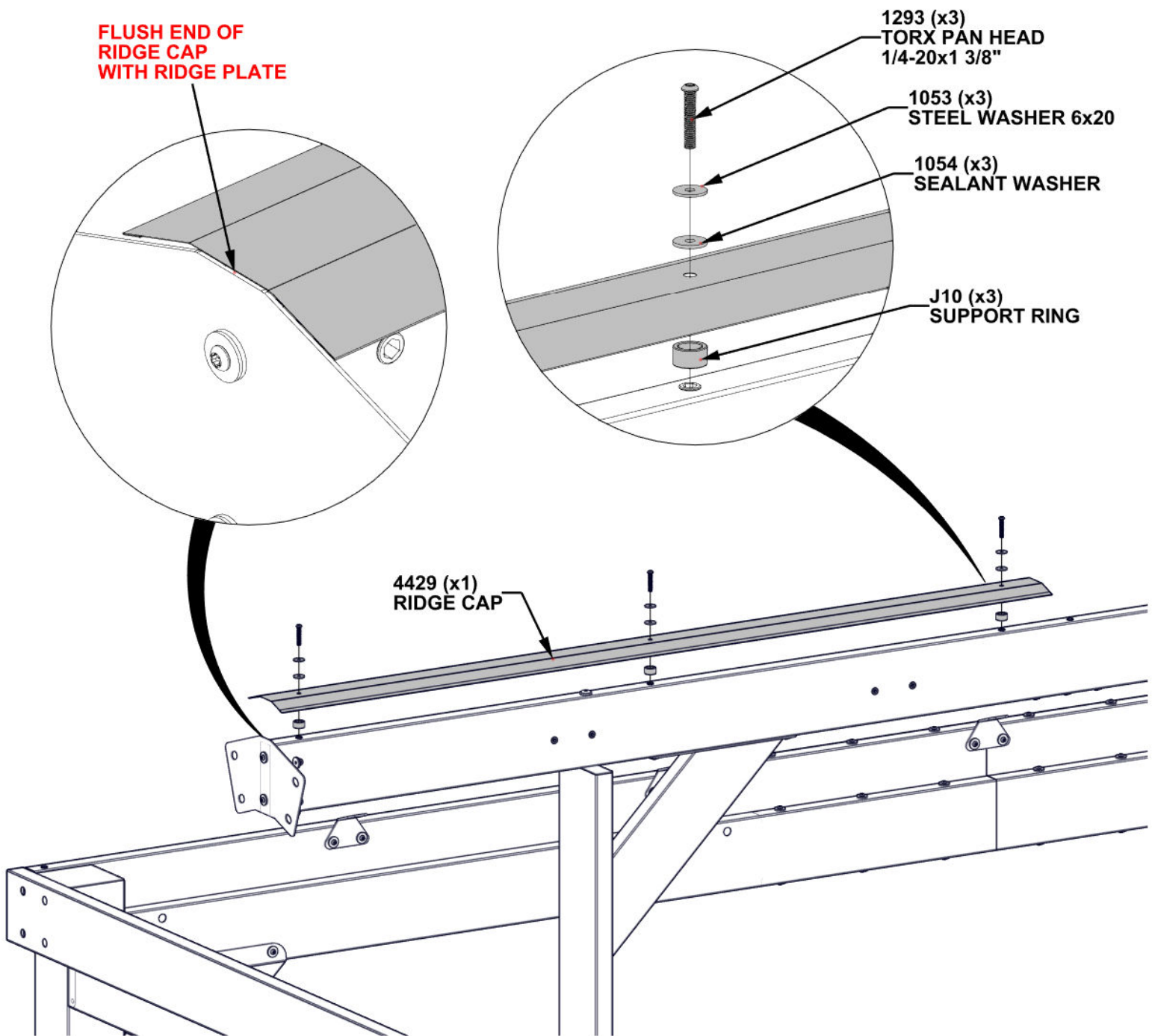

STEP 26B - RIDGE ASSEMBLY

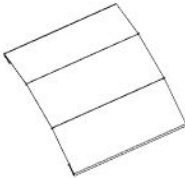

A4M03535 RIDGE CAP SPLICE
(x1)

- **WARNING: GLOVES ARE RECOMMENDED WHEN HANDLING STEEL ROOF PIECE.**
- REMOVE PROTECTIVE FILM.
- ORIENT RIDGE CAP SPLICE AS SHOWN BELOW.

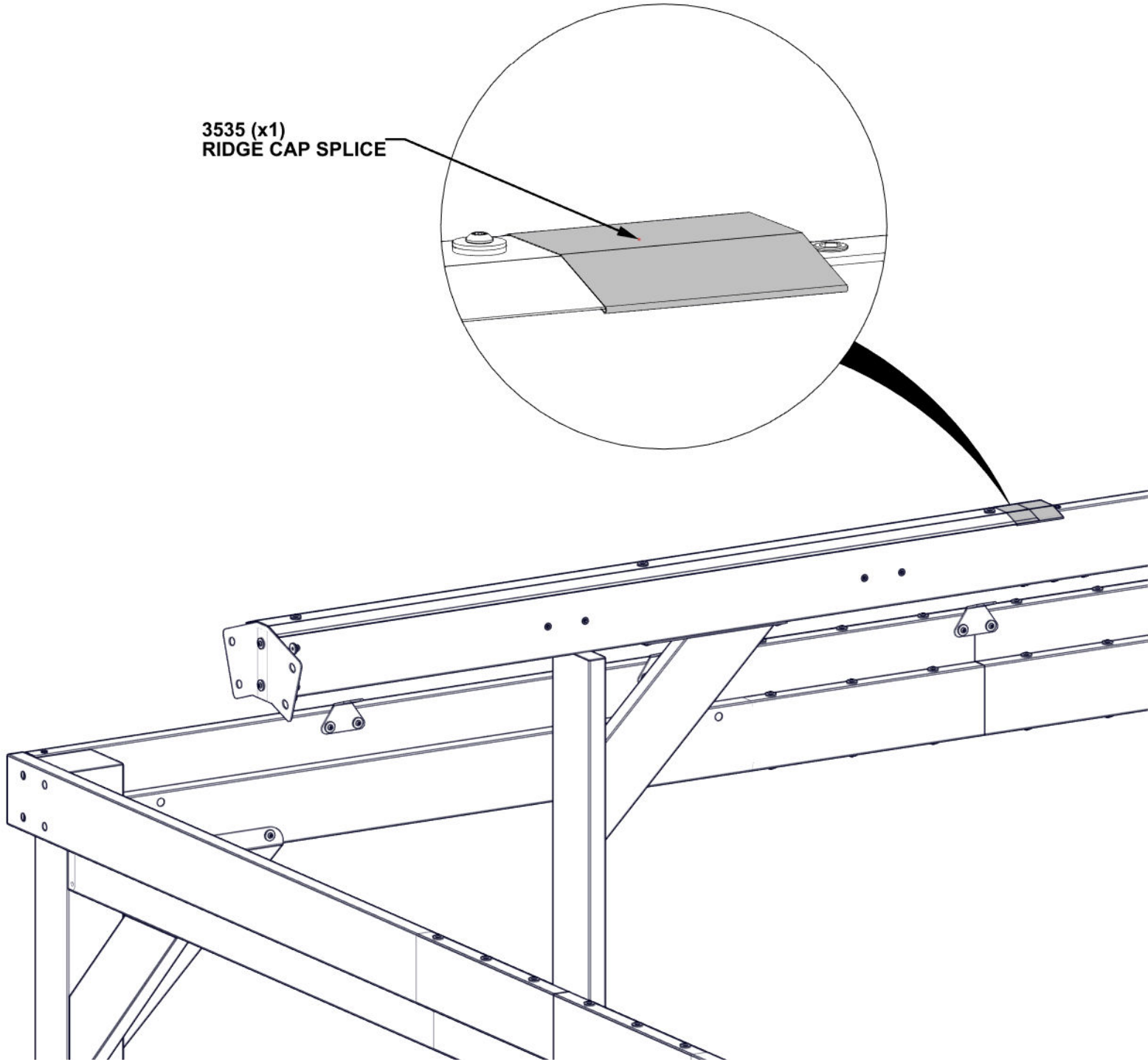

3535 (x1)
RIDGE CAP SPLICE

STEP 26C - RIDGE ASSEMBLY

Qty	PartNo	Description
3	H101053	STEEL WASHER 6x20
3	H101054	SEALANT WASHER
3	H101293	TORX PAN HEAD 1/4-20x1 3/8"

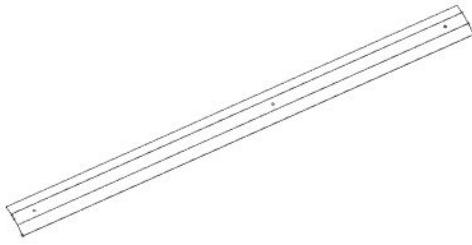

A4M04428 RIDGE CAP
(x1)



J10 SUPPORT RING - A4M03808
(x3) 13/16"x7/16" (11x20x)

- **WARNING: GLOVES ARE RECOMMENDED WHEN HANDLING STEEL ROOF PIECE.**
- REMOVE PROTECTIVE FILM.
- ORIENT RIDGE CAP AND SLIDE INTO RIDGE CAP SPLICE AS SHOWN BELOW.

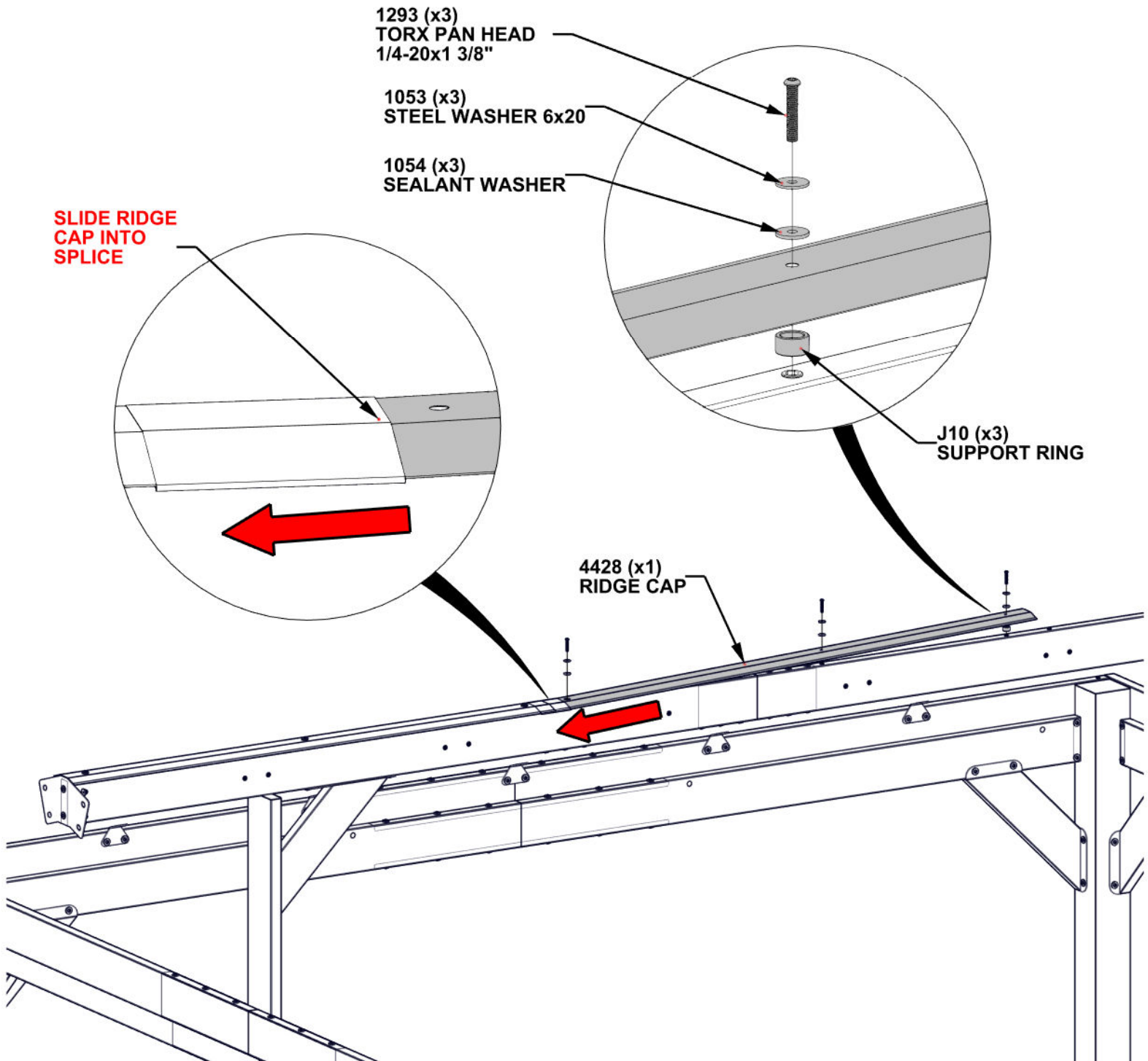

STEP 26D - RIDGE ASSEMBLY

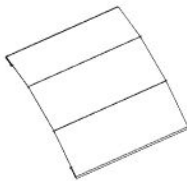

A4M03535 RIDGE CAP SPLICE
(x1)

- **WARNING: GLOVES ARE RECOMMENDED WHEN HANDLING STEEL ROOF PIECE.**
- REMOVE PROTECTIVE FILM.
- ORIENT RIDGE CAP SPLICE AS SHOWN BELOW.

3535 (x1)
RIDGE CAP SPLICE

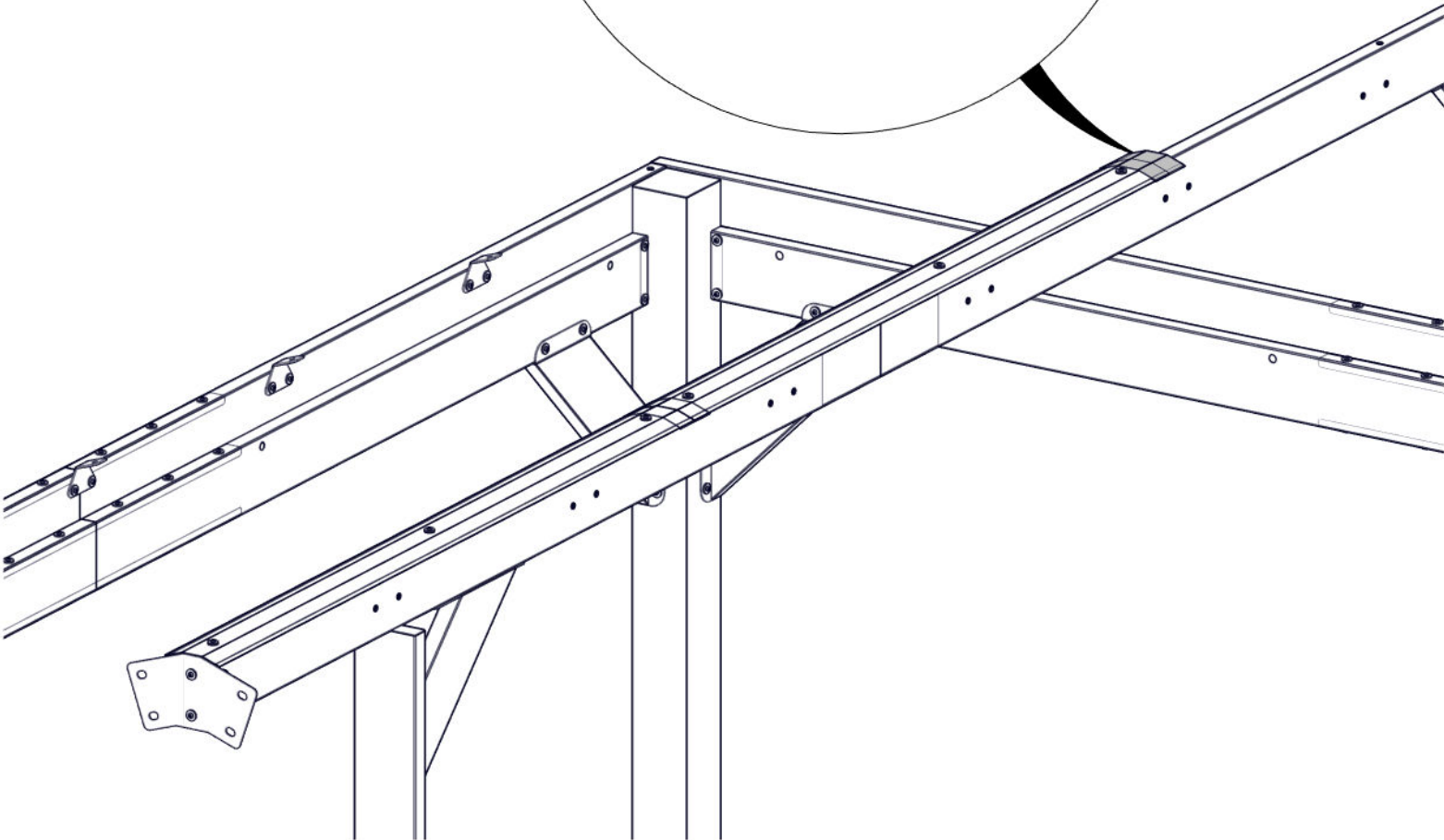
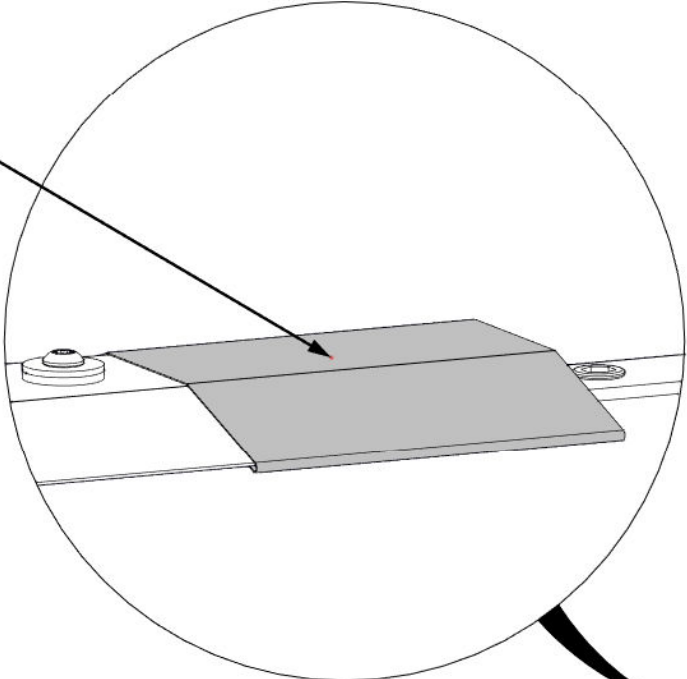

STEP 26E - RIDGE ASSEMBLY

Qty	PartNo	Description
3	H101053	STEEL WASHER 6x20
3	H101054	SEALANT WASHER
3	H101293	TORX PAN HEAD 1/4-20x1 3/8"

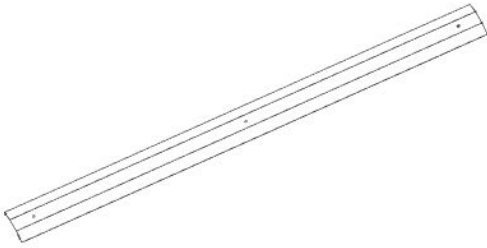

A4M04429 RIDGE CAP
(x1)

J10 SUPPORT RING - A4M03808
(x3) 13/16"x7/16" (11x20x)

- **WARNING: GLOVES ARE RECOMMENDED WHEN HANDLING STEEL ROOF PIECE.**
- REMOVE PROTECTIVE FILM.
- ORIENT RIDGE CAP AND SLIDE INTO RIDGE CAP SPLICE AS SHOWN BELOW.

1293 (x3)
TORX PAN HEAD
1/4-20x1 3/8"

1053 (x3)
STEEL WASHER 6x20

1054 (x3)
SEALANT WASHER

J10 (x3)
SUPPORT RING

**FLUSH END OF
RIDGE CAP
WITH RIDGE PLATE**

**SLIDE RIDGE
CAP INTO
SPLICE**

4429 (x1)
RIDGE CAP

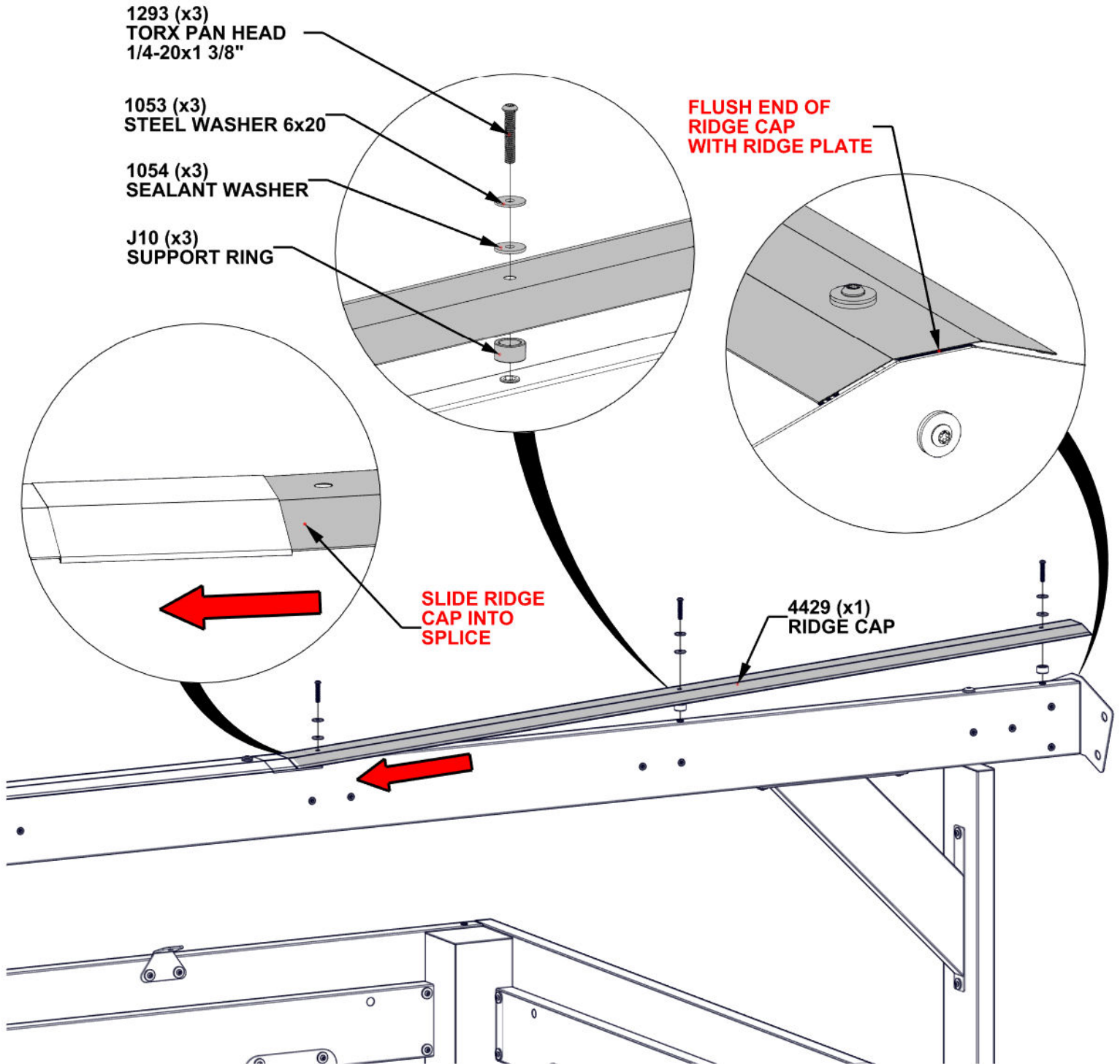

STEP 27 - ROOF ASSEMBLY

Qty	PartNo	Description
4	H101202	TORX PAN HEAD 1/4-20x3/4 ASSY



J7 RAFTER BRACKET - A4M03802
(x4) 3 5/8"x2 3/16"x2" (50x55x92)

1202 (x4)
TORX PAN HEAD 1/4-20x3/4 ASSY
HAND TIGHTEN ONLY.

J7 (x4)
RAFTER BRACKET

**BRACKET HOLES
WILL FIT AROUND
THREADED INSERTS**

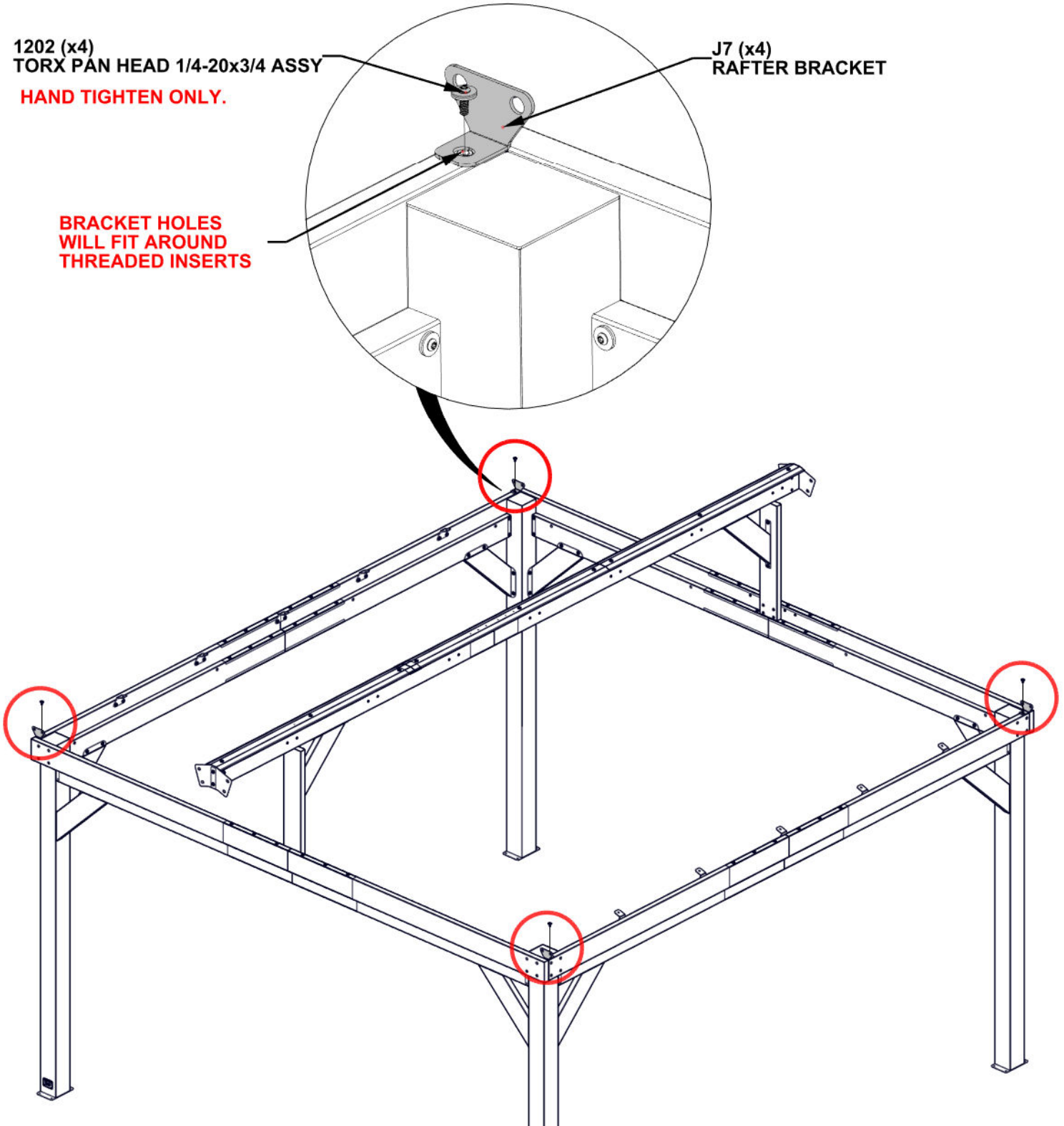

STEP 28 - ROOF ASSEMBLY

Qty	PartNo	Description
16	H101202	TORX PAN HEAD 1/4-20x3/4 ASSY



R01 RAFTER ASSEMBLY - A4M03522
(x2) 86 3/8"x4 5/16"x3 1/8" (80x110x2194.6)



R02 RAFTER ASSEMBLY - A4M03523
(x2) 86 3/8"x4 5/16"x3 1/8" (80x110x2194.6)

- INSERTS ON THE SIDE OF EACH RAFTER MUST FACE TOWARD THE INSIDE OF THE STRUCTURE AS SHOWN IN SMALL CIRCLES.
- ATTACH EACH RAFTER AT THE RIDGE AS SHOWN BELOW.
- ONCE SUPPORTED, ATTACH END OF RAFTER TO RAFTER BRACKETS AT TOP OF EACH POST.

BRACKET HOLES WILL FIT AROUND THREADED INSERTS

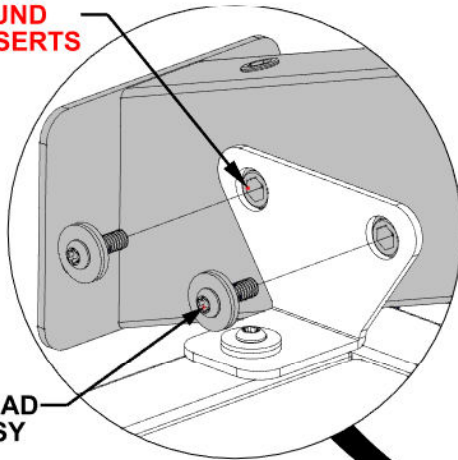

1202 (x8)
TORX PAN HEAD
1/4-20x3/4 ASSY

HAND TIGHTEN ONLY.

BRACKET HOLES WILL FIT AROUND THREADED INSERTS

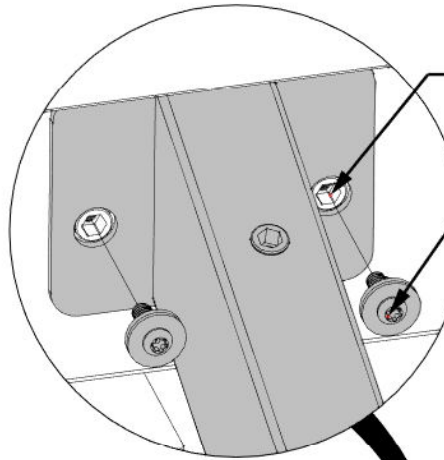

1202 (x8)
TORX PAN HEAD
1/4-20x3/4 ASSY

HAND TIGHTEN ONLY.

R02 (x1)
RAFTER
ASSEMBLY

R01 (x1)
RAFTER
ASSEMBLY

R01 (x1)
RAFTER
ASSEMBLY

R02 (x1)
RAFTER
ASSEMBLY

FRONT

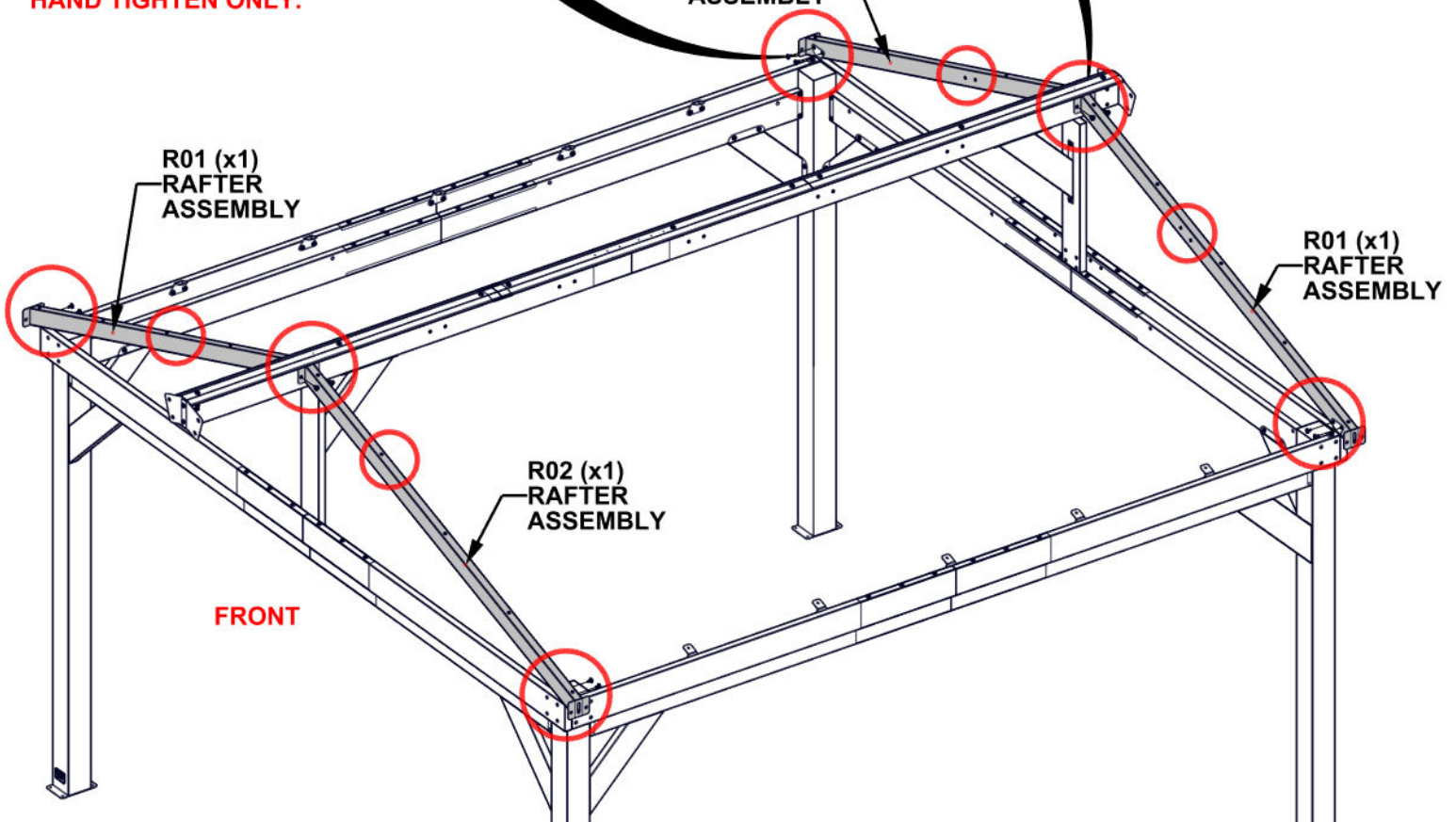

STEP 29 - ROOF ASSEMBLY

Qty	PartNo	Description
16	H101103	TORX SOCKET SCREW 1/4-20



B08 GABLE ARM ASSEMBLY - A4M03514
(x2) 40 1/16"x5 1/4"x1 7/16" (36x134x1017)



B09 GABLE ARM ASSEMBLY - A4M03515
(x2) 40 1/16"x5 1/4"x1 7/16" (36x134x1017)

FLUSH TOP SURFACE OF GABLE AND RAFTER

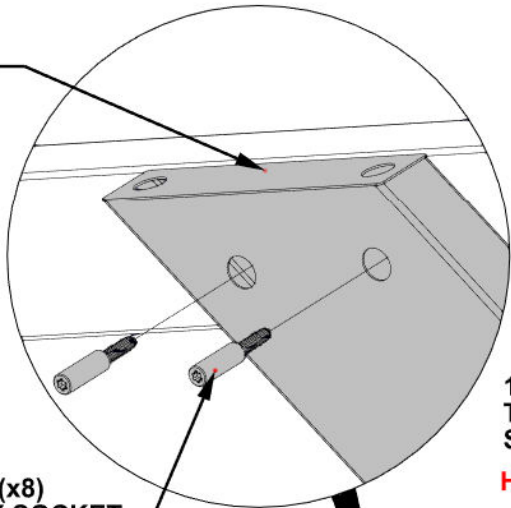

**1103 (x8)
TORX SOCKET
SCREW 1/4-20**

HAND TIGHTEN ONLY.

**1103 (x8)
TORX SOCKET
SCREW 1/4-20**

HAND TIGHTEN ONLY.

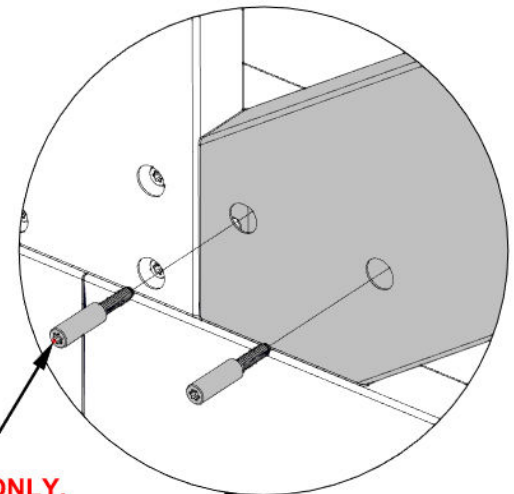

**B09 (x1)
GABLE ARM
ASSEMBLY**

**B08 (x1)
GABLE ARM
ASSEMBLY**

**B08 (x1)
GABLE ARM
ASSEMBLY**

**B09 (x1)
GABLE ARM
ASSEMBLY**

FRONT

STEP 30A - ROOF ASSEMBLY

Qty	PartNo	Description
20	H101202	TORX PAN HEAD 1/4-20x3/4 ASSY



R03 RAFTER ASSEMBLY - A4M03524
(x10) 86 3/8"x4 5/16"x3 1/8" (80x110x219.6)

- ATTACH EACH RAFTER AT THE RIDGE AS SHOWN BELOW.

**BRACKET HOLES
WILL FIT AROUND
THREADED INSERTS**

1202 (x20)
TORX PAN HEAD 1/4-20x3/4 ASSY

HAND TIGHTEN ONLY

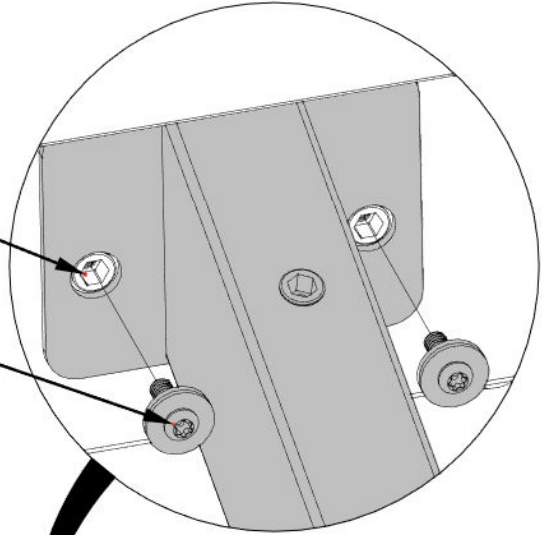

R03 (x10)
RAFTER ASSEMBLY



STEP 30B - ROOF ASSEMBLY

Qty	PartNo	Description
10	H101202	TORX PAN HEAD 1/4-20x3/4 ASSY

- ATTACH END OF EACH RAFTER TO BRACKETS ALONG SIDE BEAMS.

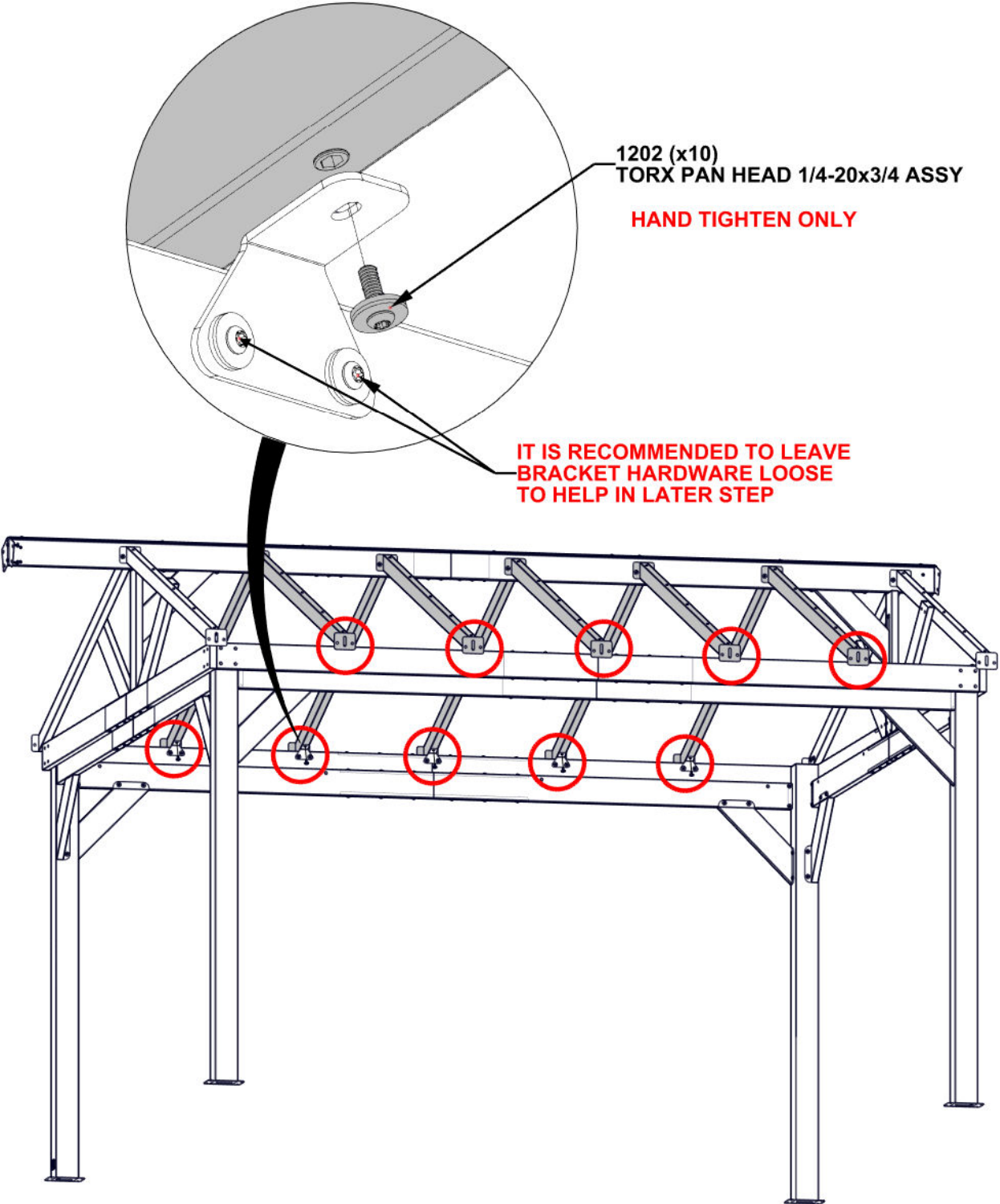

STEP 31A - ROOF ASSEMBLY

Qty	PartNo	Description
12	H101202	TORX PAN HEAD 1/4-20x3/4 ASSY



B15 DRIP BEAM ASSEMBLY - A4M04421
(x2) 95 3/16"x4 13/16"x1 7/16" (36x122x2417.75)

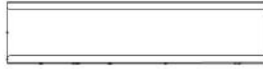

J6 SPLICE BRACKET - A4M03806
(x2) 19 11/16"x4 11/16"x32.5 (32.5x118.5x500)

- BEAM AND SPLICE MUST BE ORIENTED AS SHOWN BELOW. SLIDE J6 INTO B15 AND LINE UP THREE HOLES TOP AND BOTTOM

- REPEAT THIS STEP TWICE

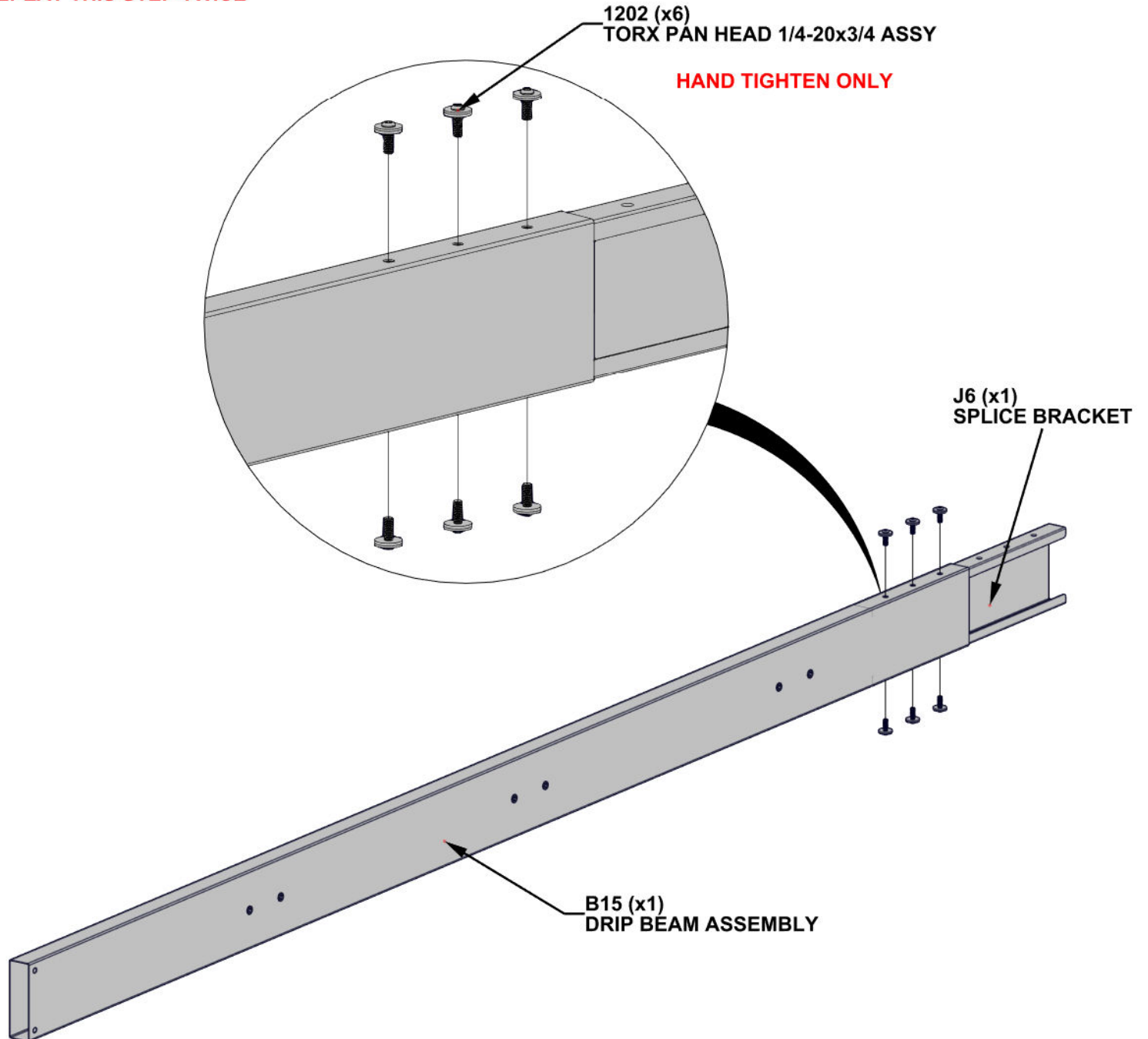

STEP 31B - ROOF ASSEMBLY

Qty	PartNo	Description
12	H101202	TORX PAN HEAD 1/4-20x3/4 ASSY



B14 DRIP BEAM ASSEMBLY - A4M04420
(x2) 95 3/16"x4 13/16"x1 7/16" (36x122x2417.75)

- SLIDE B14 ONTO SPLICE BRACKET.
GENTLY TAP ENDS OF ASSEMBLY WITH
RUBBER Mallet UNTIL GAP CLOSES.

- REPEAT THIS STEP TWICE

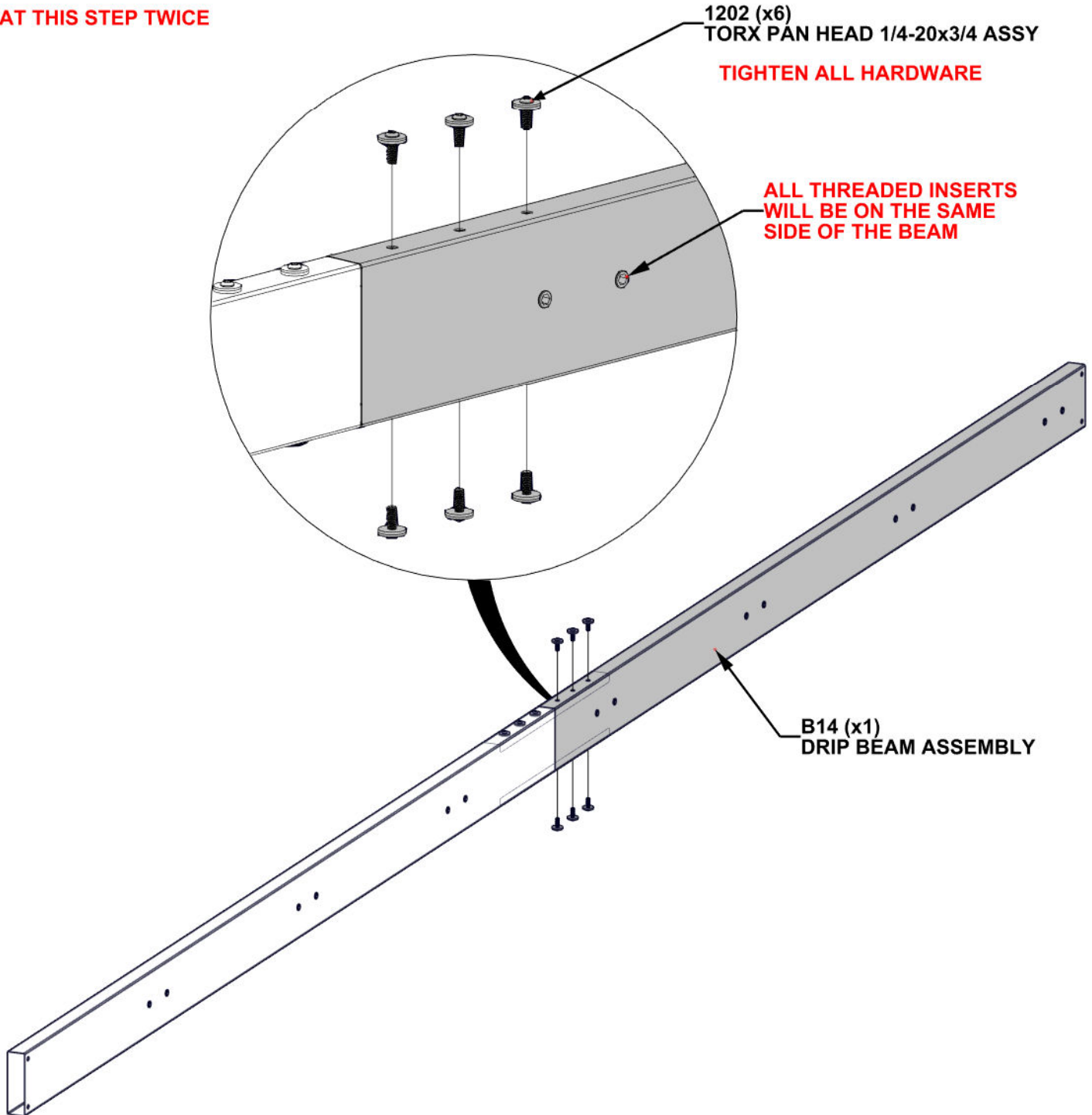

STEP 31C - ROOF ASSEMBLY

Qty	PartNo	Description
28	H101202	TORX PAN HEAD 1/4-20x3/4 ASSY

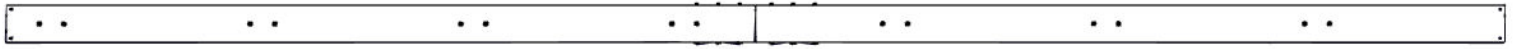

ROOF ASSEMBLY FROM STEPS 31A-31B

- WITH AT LEAST TWO ADDITIONAL PEOPLE, ATTACH BEAM ASSEMBLY TO RAFTER ENDS.
- BEAM ASSEMBLY MUST BE ORIENTED AS SHOWN BELOW WITH LONG OVERHANG TOWARD THE FRONT

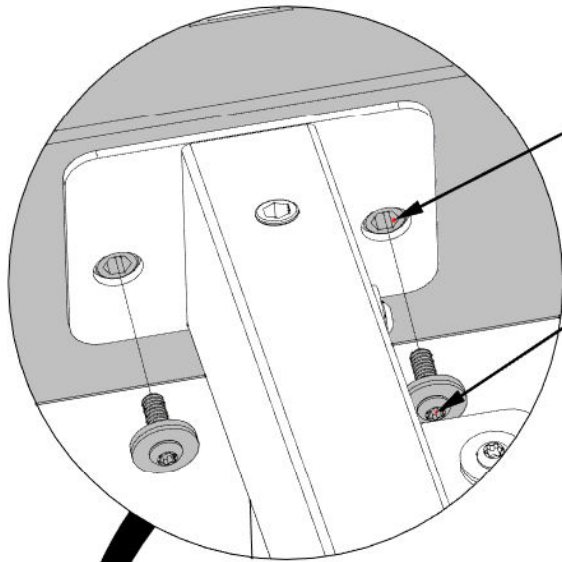

BRACKET HOLES
WILL FIT AROUND
THREADED INSERTS

1202 (x28)
TORX PAN HEAD 1/4-20x3/4 ASSY

HAND TIGHTEN ONLY

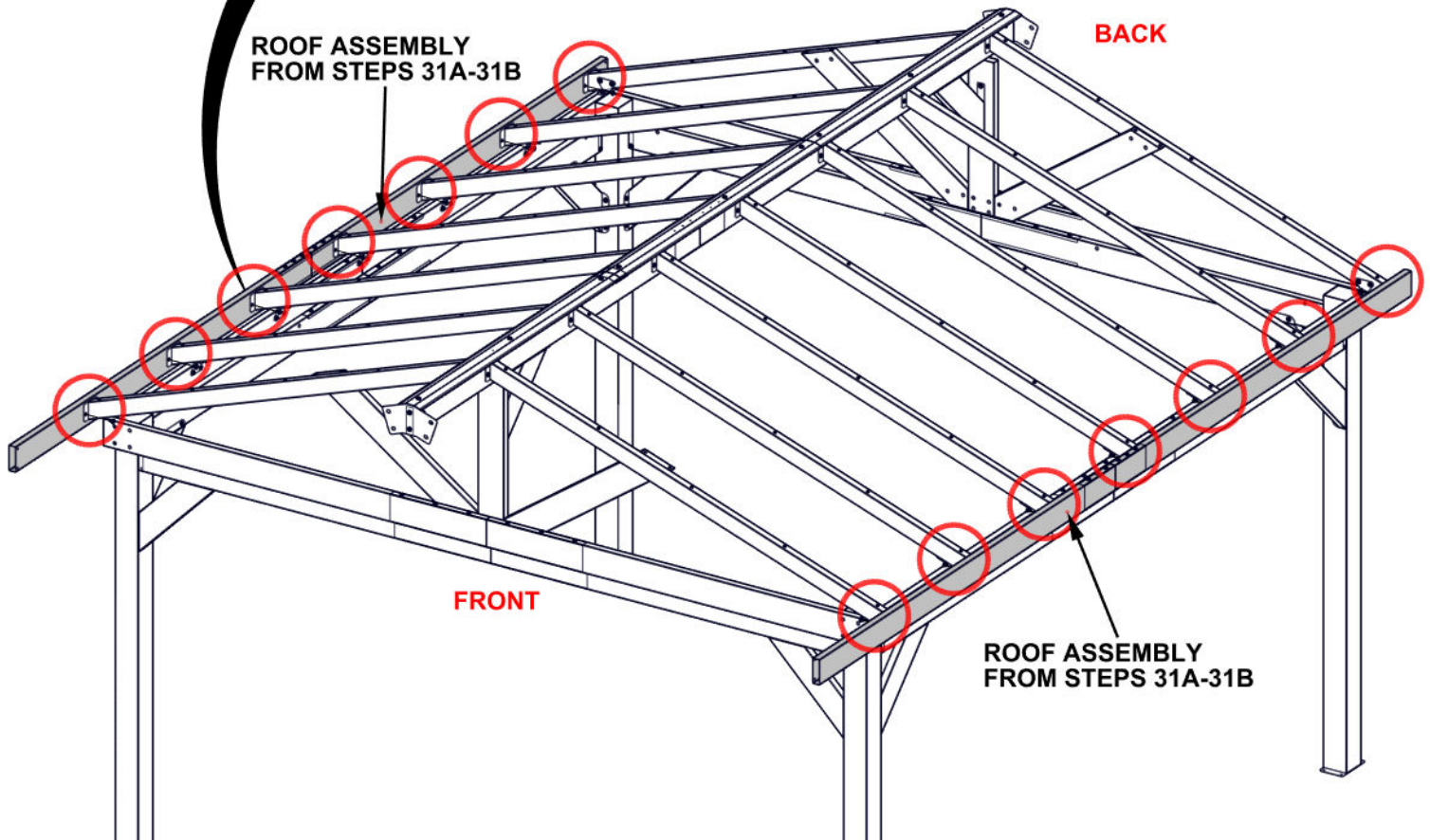

STEP 32 - ROOF ASSEMBLY

Qty	PartNo	Description
4	H101202	TORX PAN HEAD 1/4-20x3/4 ASSY

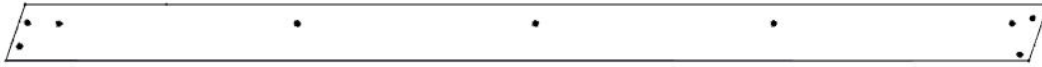

B13 GABLE BEAM ASSEMBLY - A4M03519
 (x2) 88 13/16"x5 1/4"x1 7/16" (36x134x2255)

J9 BEAM BRACKET - A4M03807
 (x2) 5 9/16"x1 5/16"x4 9/16" (140.57x33.20x116)

- REPEAT THIS STEP TWICE

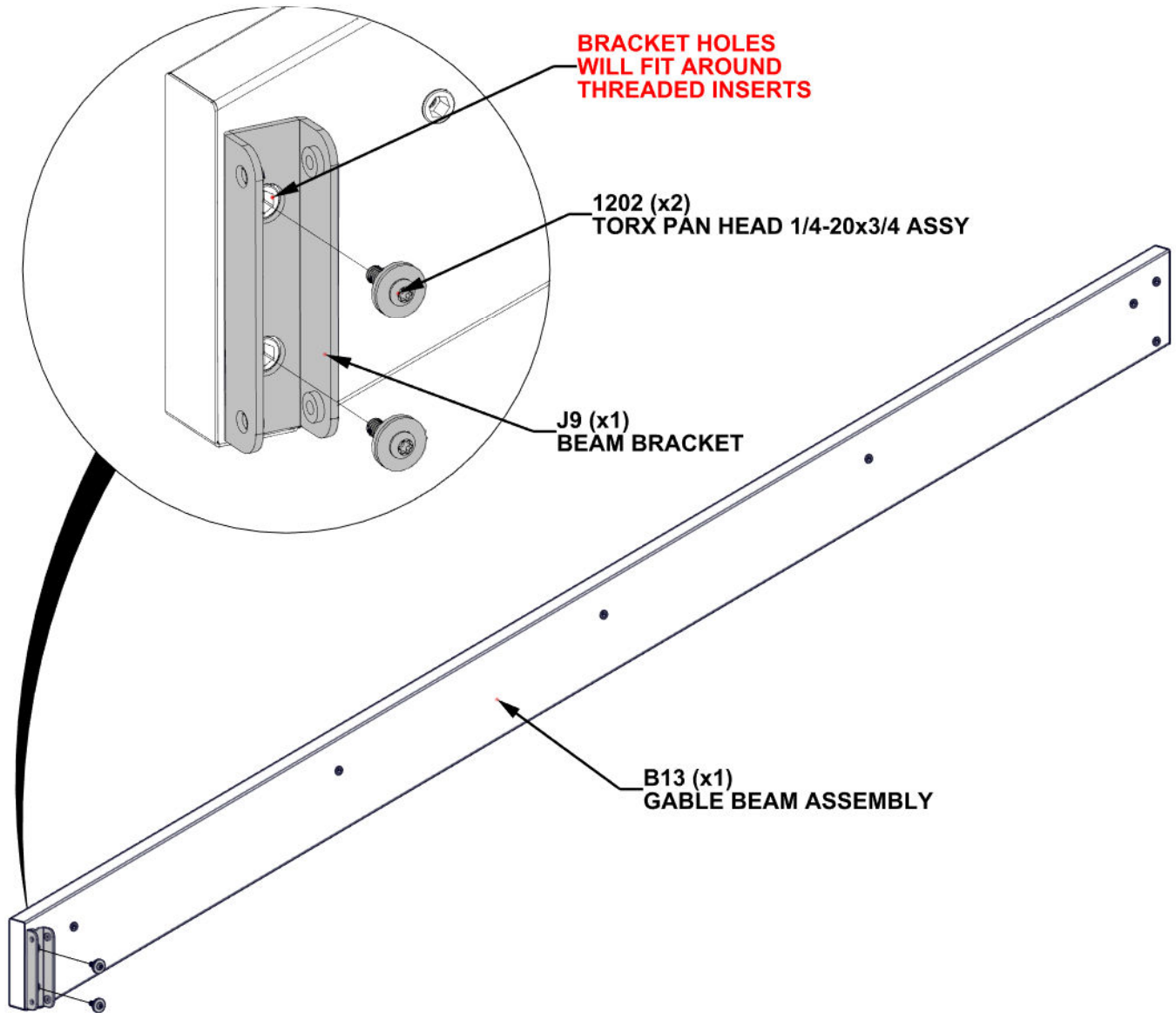

STEP 33 - ROOF ASSEMBLY

Qty	PartNo	Description
4	H101202	TORX PAN HEAD 1/4-20x3/4 ASSY

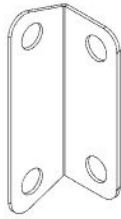

J8 GABLE BRACKET - A4M03804
(x2) 4 13/16"x1 9/16"x1 9/16" (40x40x123)

- REPEAT THIS STEP TWICE

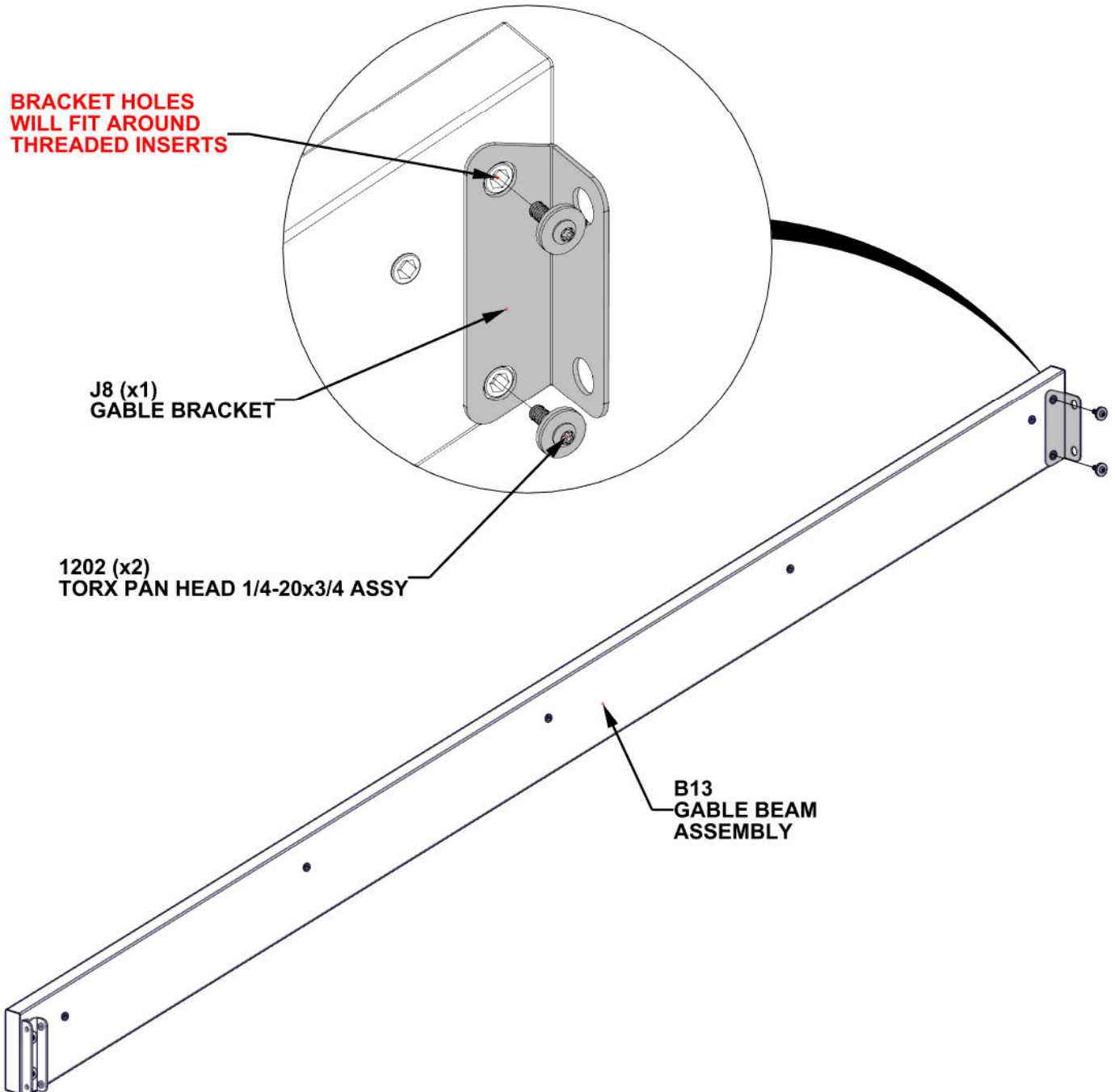

STEP 34A - ROOF ASSEMBLY

Qty	PartNo	Description
4	H101202	TORX PAN HEAD 1/4-20x3/4 ASSY

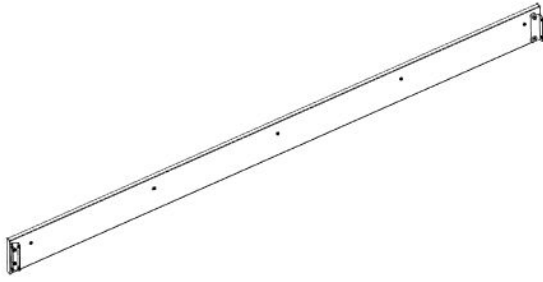

ROOF ASSEMBLY FROM STEPS 32 - 33

- WITH AT LEAST TWO ADDITIONAL PEOPLE, ATTACH GABLE BEAM ASSEMBLY.
- REPEAT THIS STEP TWICE FOR BOTH SIDES OF STRUCTURE

BRACKET HOLES WILL FIT AROUND THREADED INSERTS

1202 (x4)
TORX PAN HEAD
1/4-20x3/4 ASSY

HAND TIGHTEN ONLY

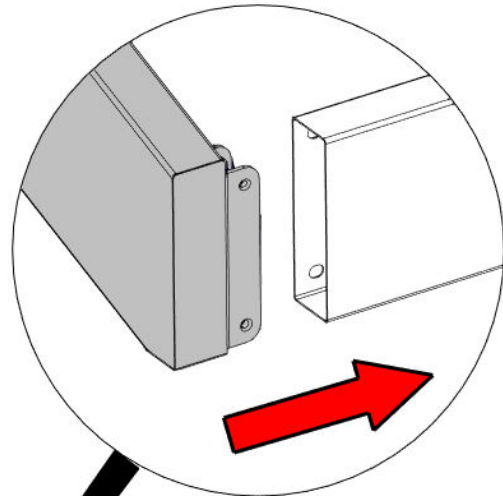

GABLE BEAM ASSEMBLY

BACK

GABLE BEAM ASSEMBLY

FRONT

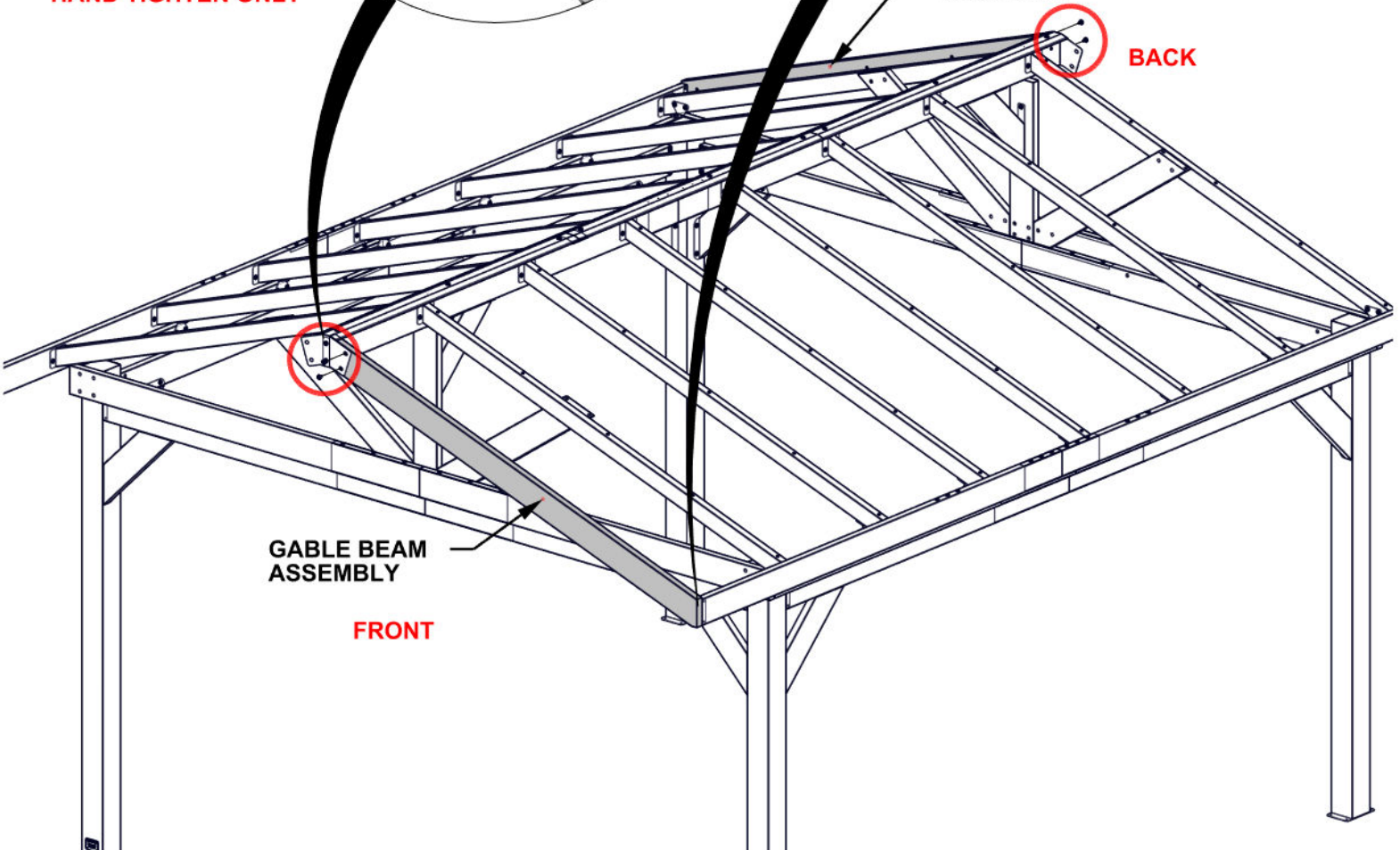

STEP 34B - ROOF ASSEMBLY

Qty	PartNo	Description
8	H101202	TORX PAN HEAD 1/4-20x3/4 ASSY

- REPEAT THIS STEP TWICE FOR BOTH SIDES OF STRUCTURE

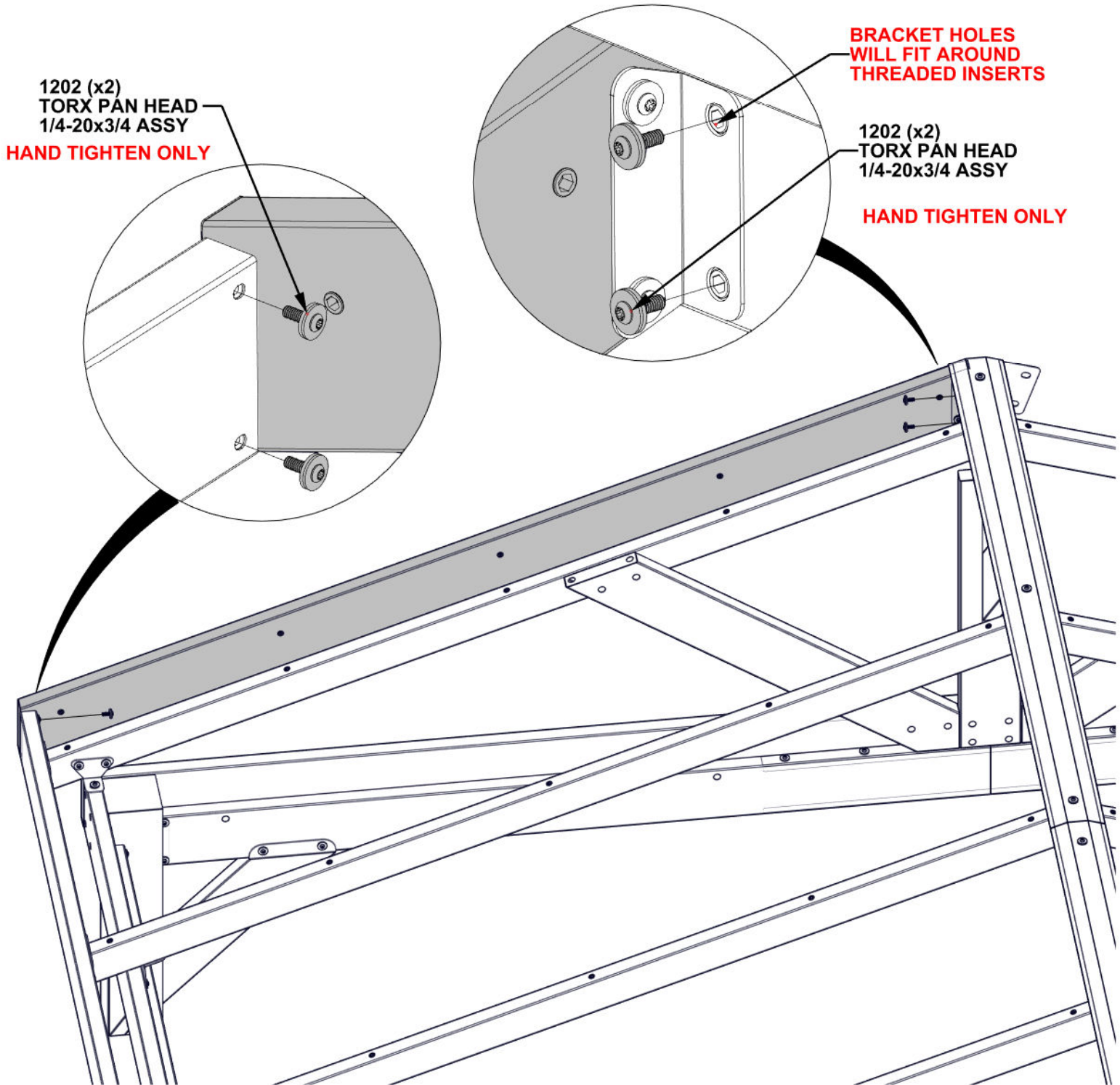

STEP 35 - ROOF ASSEMBLY

Qty	PartNo	Description
4	H101202	TORX PAN HEAD 1/4-20x3/4 ASSY

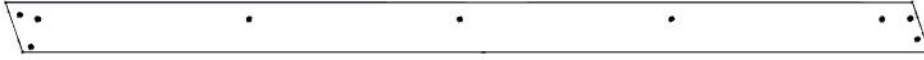

B12 GABLE BEAM ASSEMBLY - A4M03518
(x2) 88 13/16"x5 1/4"x1 7/16" (36x134x2255)

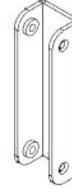

J9 BEAM BRACKET - A4M03807
(x2) 5 9/16"x1 5/16"x4 9/16" (140.57x33.20x116)

- REPEAT THIS STEP TWICE

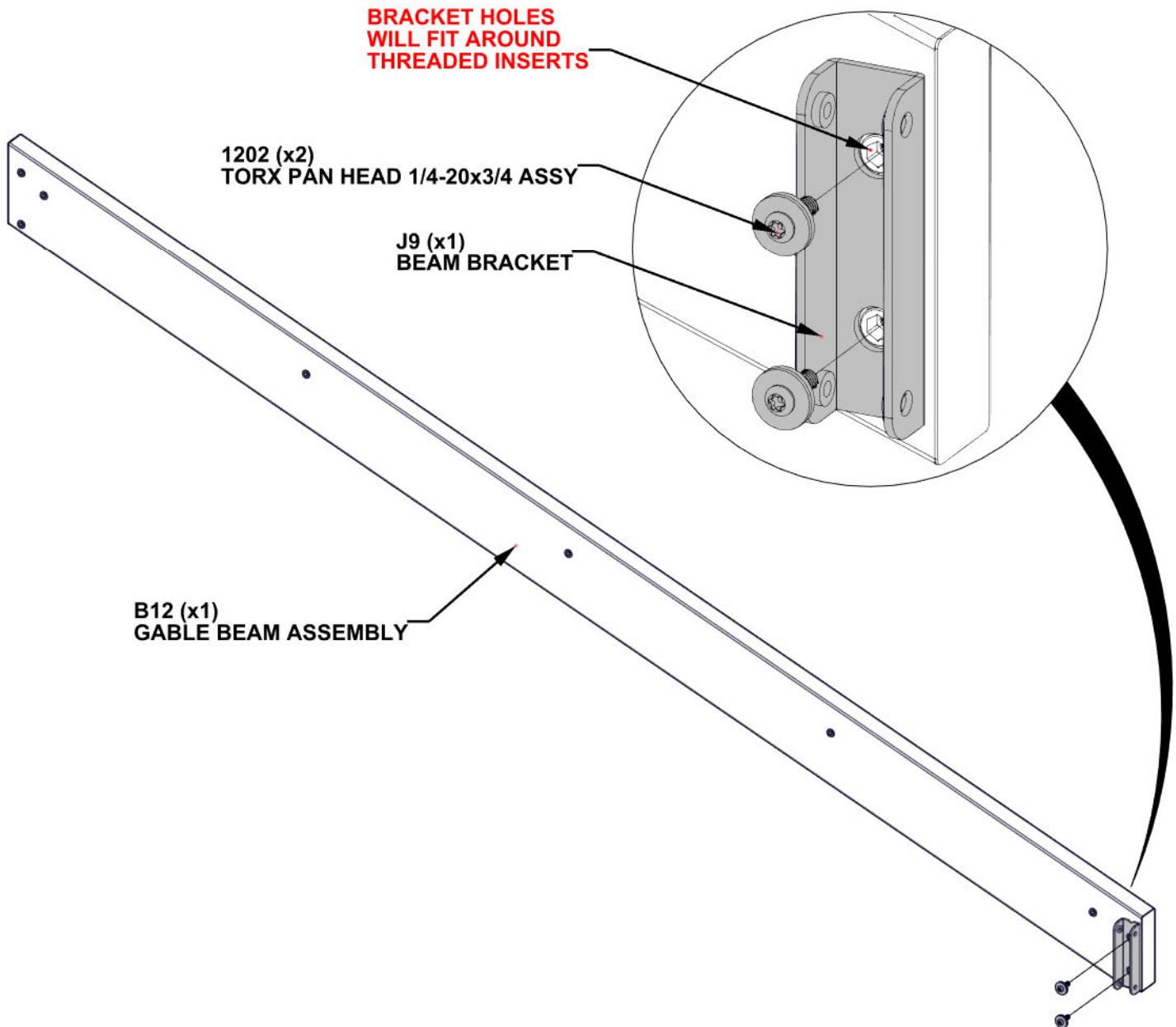

STEP 36 - ROOF ASSEMBLY

Qty	PartNo	Description
4	H101202	TORX PAN HEAD 1/4-20x3/4 ASSY

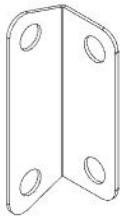

J8 GABLE BRACKET - A4M03804
(x2) 4 13/16"x1 9/16"x1 9/16" (40x40x123)

- REPEAT THIS STEP TWICE

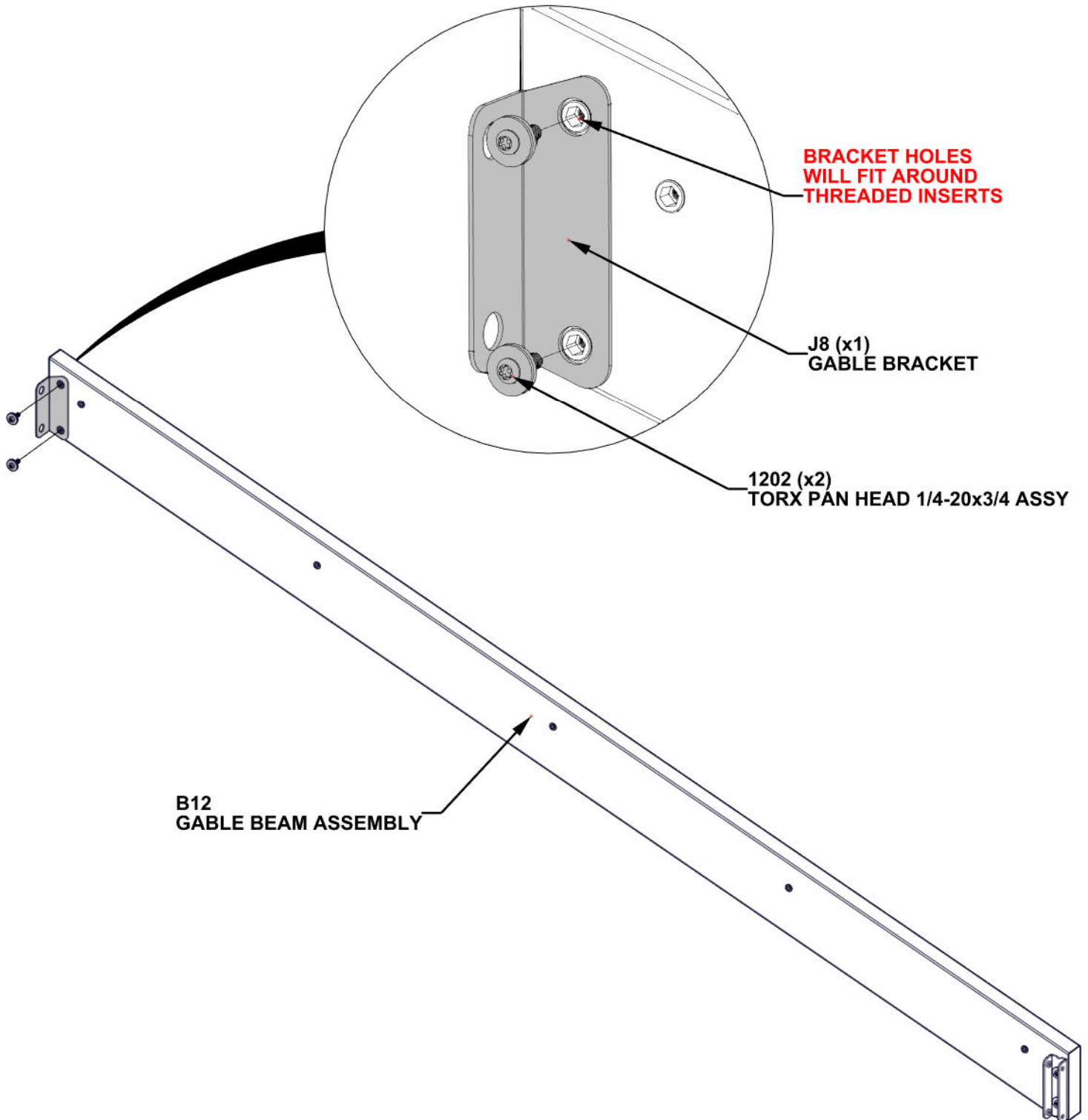

STEP 37A - ROOF ASSEMBLY

Qty	PartNo	Description
4	H101202	TORX PAN HEAD 1/4-20x3/4 ASSY

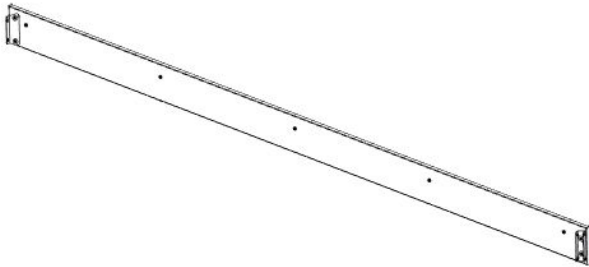

ROOF ASSEMBLY FROM STEPS 35 - 36

- WITH AT LEAST TWO ADDITIONAL PEOPLE, ATTACH GABLE BEAM ASSEMBLY.
- REPEAT THIS STEP TWICE FOR BOTH SIDES OF STRUCTURE

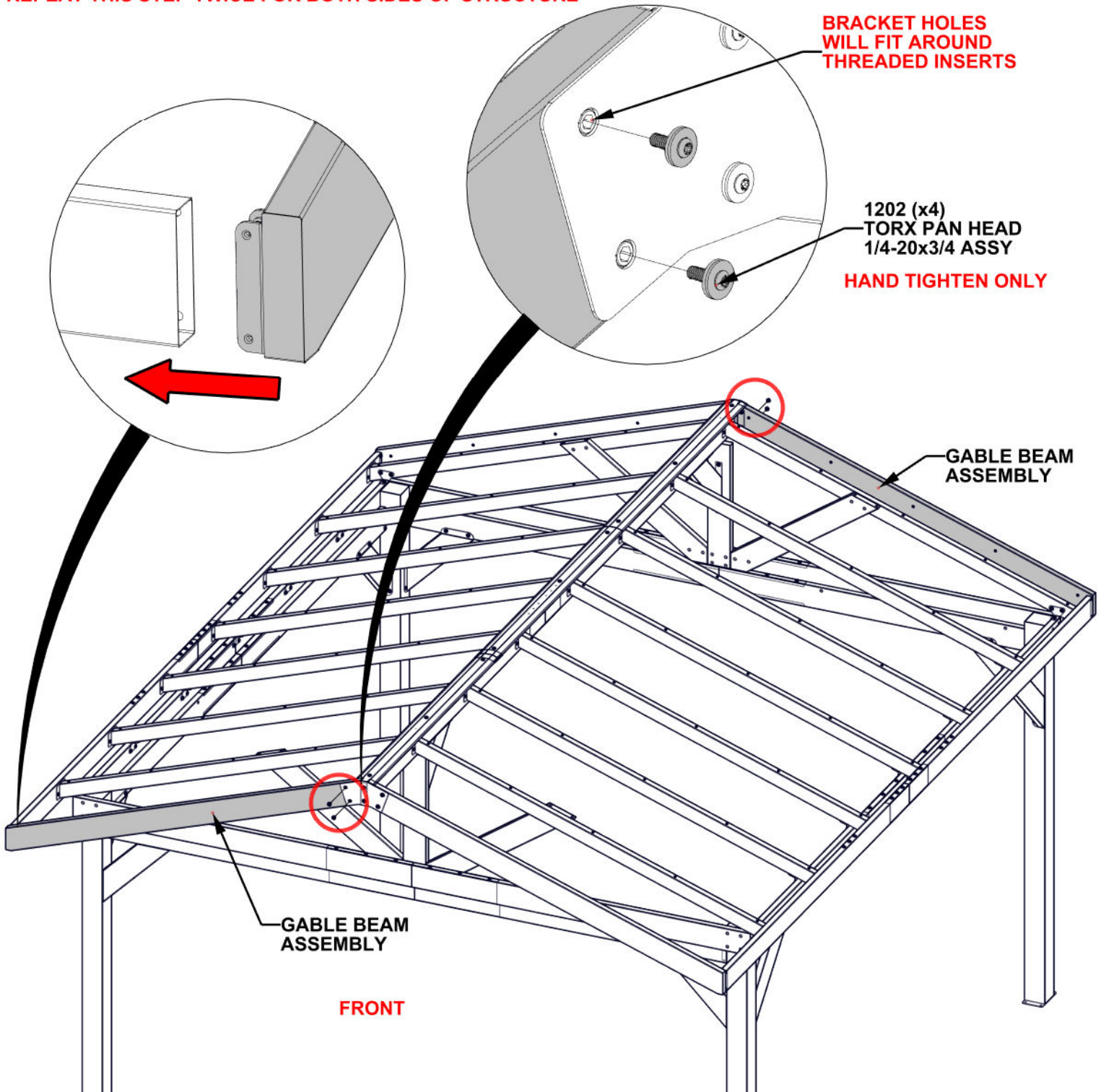

STEP 37B - ROOF ASSEMBLY

Qty	PartNo	Description
8	H101202	TORX PAN HEAD 1/4-20x3/4 ASSY

- REPEAT THIS STEP TWICE FOR BOTH SIDES OF STRUCTURE.

BRACKET HOLES
WILL FIT AROUND
THREADED INSERTS

1202 (x2)
TORX PAN HEAD
1/4-20x3/4 ASSY
HAND TIGHTEN ONLY

1202 (x2)
TORX PAN HEAD
1/4-20x3/4 ASSY
HAND TIGHTEN ONLY

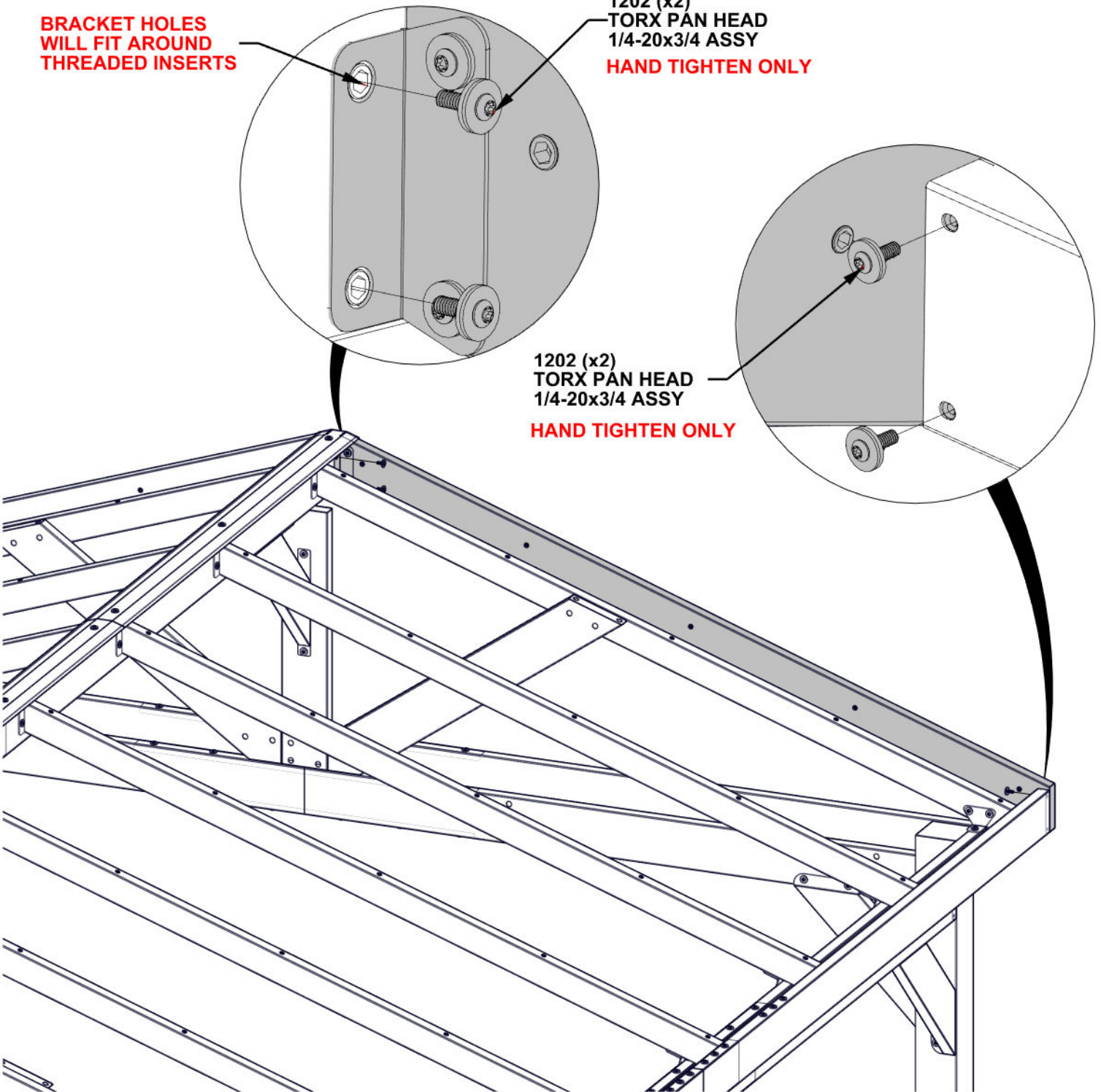

STEP 38A - PURLIN ASSEMBLY



E01 PURLIN ASSEMBLY - A4M04423
(x10) 104 1/16"x1 9/16"x13/16" (40x50x2645.40)

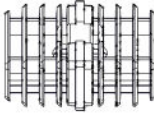

A6P00530 2-WAY SQUARE PLUG
(x10)

- ATTACH 2-WAY PLUG (530) TO E01 PURLIN.
- USE A RUBBER Mallet TO TAP 2-WAY SQUARE PLUG INTO END OF PURLIN.
- REPEAT THIS STEP 10 TIMES.

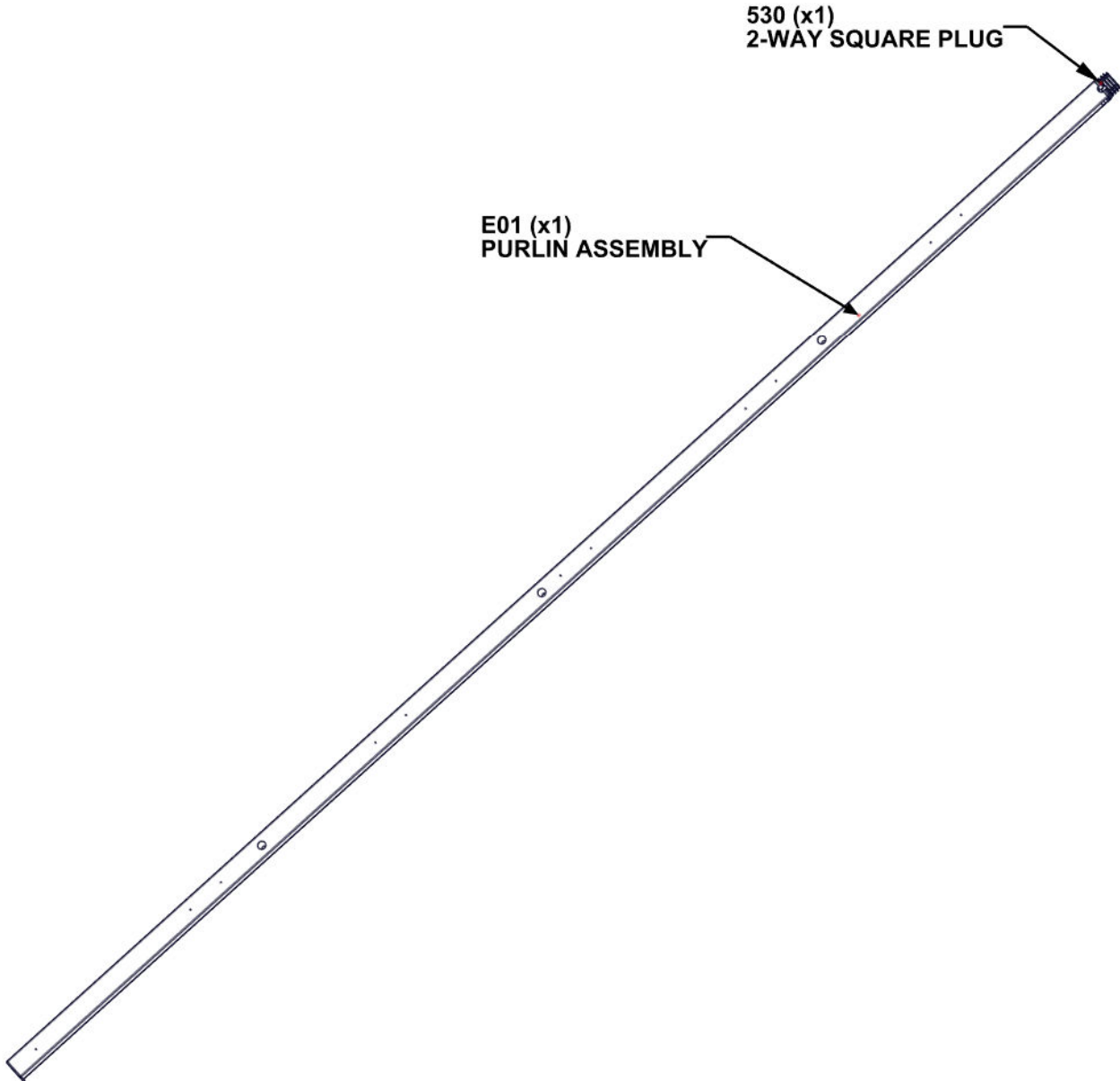

STEP 38B - ROOF ASSEMBLY

Qty	PartNo	Description
4	H101132	TORX SOCKET SCREW SHORT 1/4-20

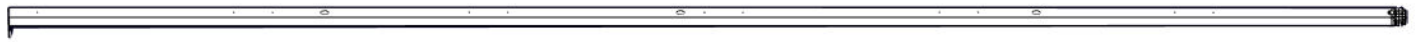

PURLIN ASSEMBLY FROM STEP 38A
(x2)

- WITH ONE EXTRA PERSON, ATTACH TWO PURLIN ASSEMBLIES FROM 38A.
- STARTING AT THE RIDGE AND WORKING DOWN WILL MAKE IT EASIER TO INSTALL PURLIN ASSEMBLIES.

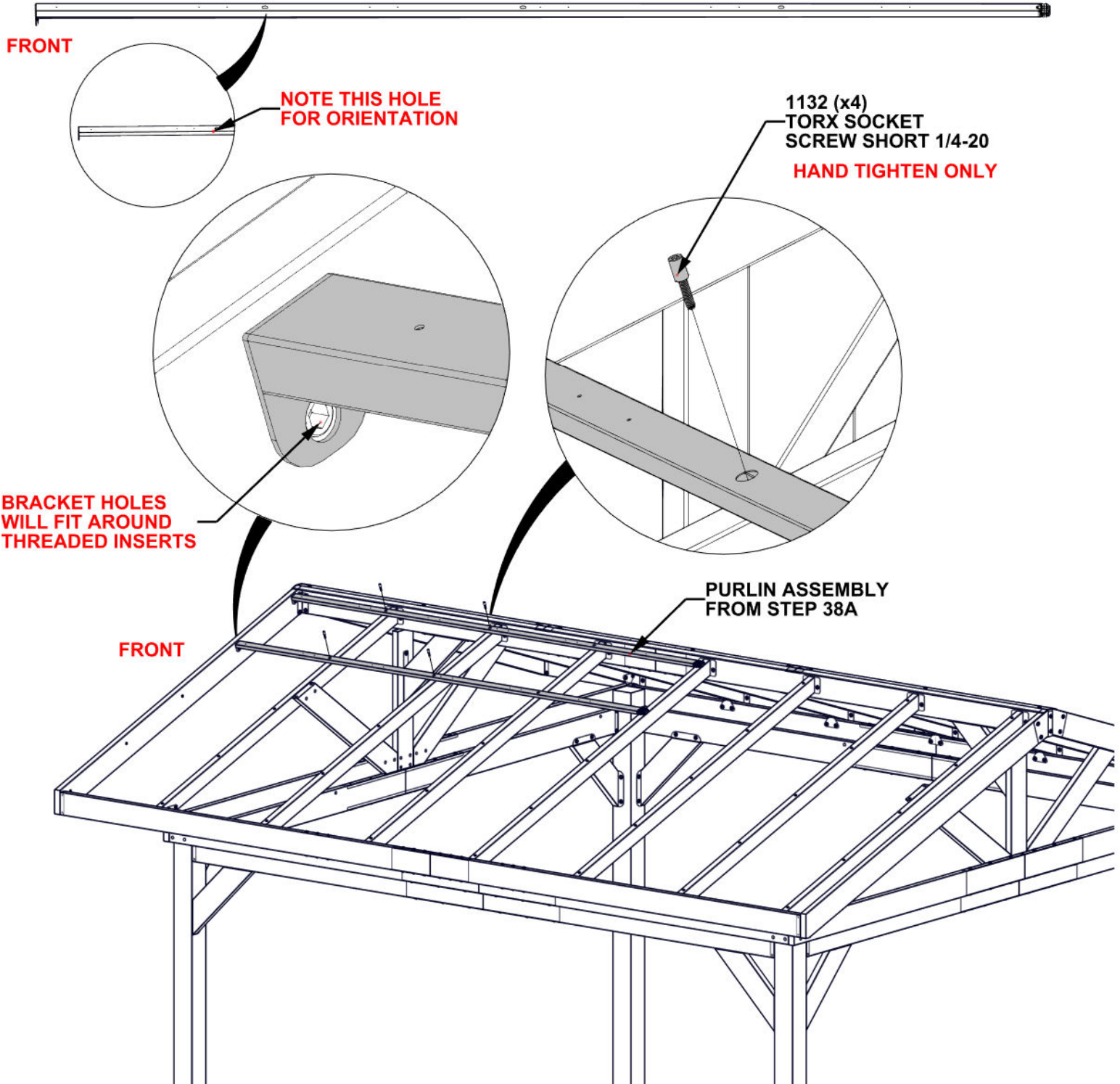

STEP 38C - ROOF ASSEMBLY

Qty	PartNo	Description
10	H101132	TORX SOCKET SCREW SHORT 1/4-20

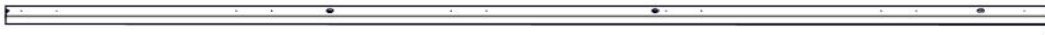

E02 PURLIN ASSEMBLY - A4M04424
 (x2) 86 1/16"x1 15/16"x1 9/16" (40x50x2185.40)

- WITH ONE EXTRA PERSON, ATTACH TWO E02 PURLINS.
- STARTING AT THE RIDGE AND WORKING DOWN WILL MAKE IT EASIER TO INSTALL PURLIN ASSEMBLIES.



NOTE THIS HOLE FOR ORIENTATION

BACK

1132 (x10)
TORX SOCKET
SCREW SHORT 1/4-20
HAND TIGHTEN ONLY

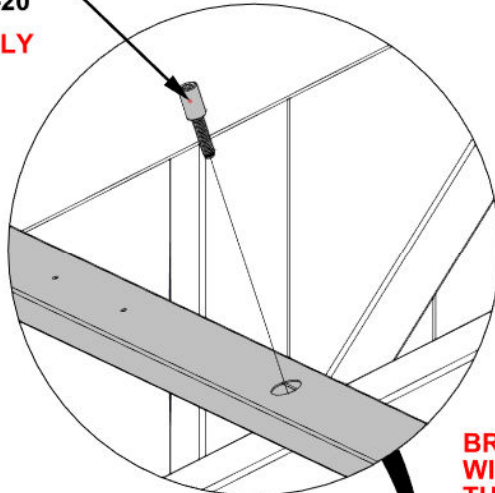

BRACKET HOLES
WILL FIT AROUND
THREADED INSERTS

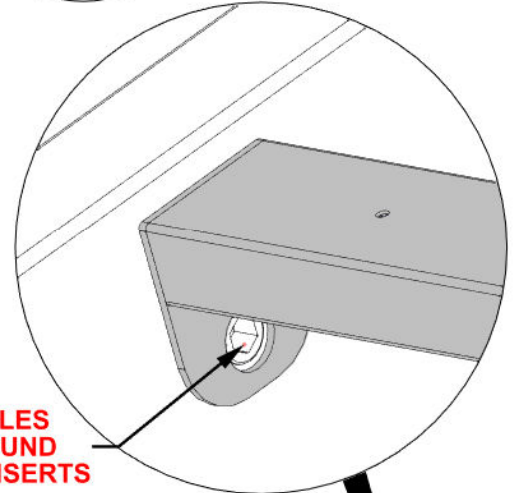

E02 (x2)
PURLIN
ASSEMBLY

FRONT

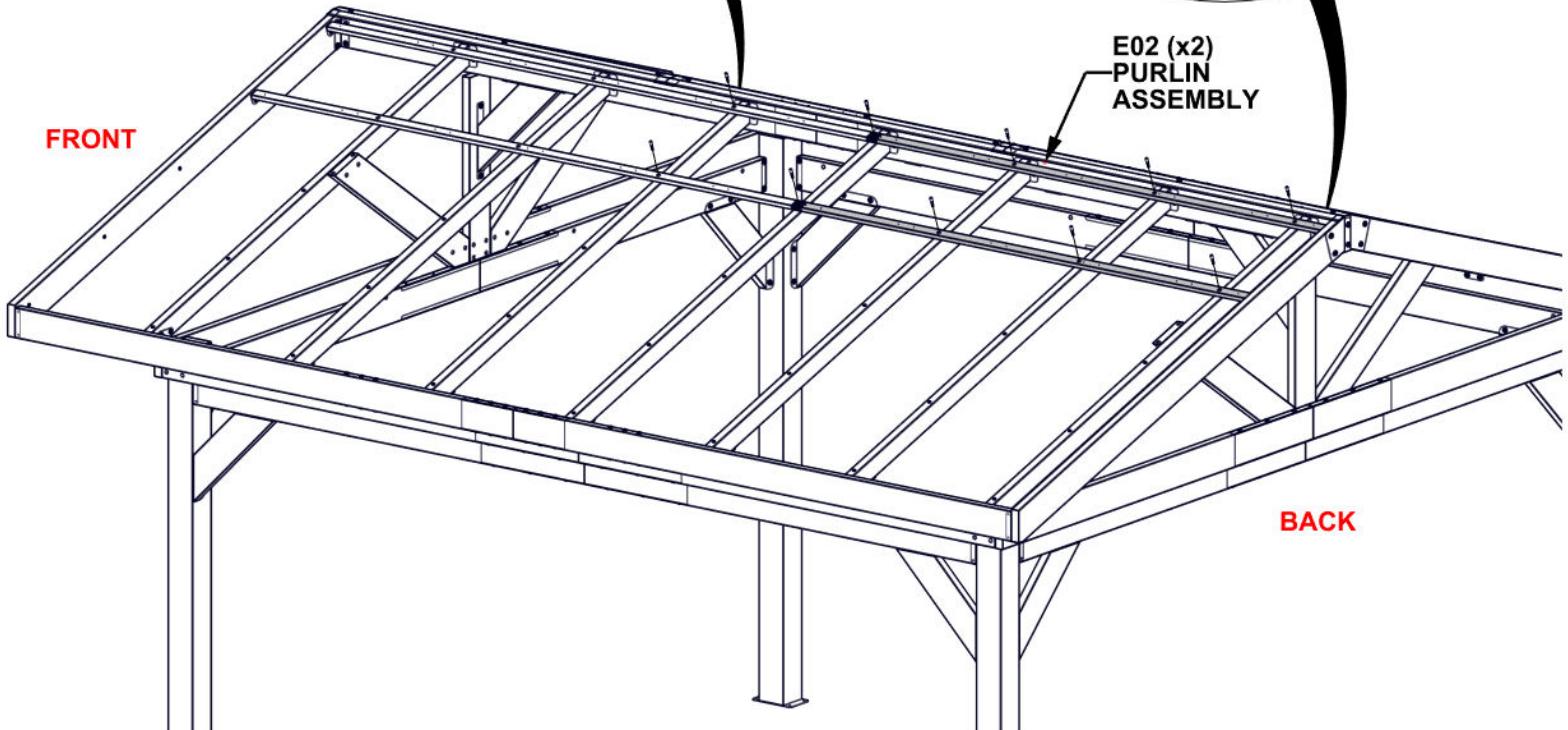

BACK

STEP 38D - ROOF ASSEMBLY

Qty	PartNo	Description
56	H101132	TORX SOCKET SCREW SHORT 1/4-20



PURLIN ASSEMBLY FROM STEP 38A
(x8)



E02 PURLIN ASSEMBLY - A4M04424
(x8) 86 1/16"x1 15/16"x1 9/16" (40x50x2185.40)

- WITH ONE EXTRA PERSON, ATTACH REMAINDER PURLINS IN THE SAME WAY AS PREVIOUS TWO STEPS .
- STARTING AT THE RIDGE AND WORKING DOWN WILL MAKE IT EASIER TO INSTALL PURLIN ASSEMBLIES.

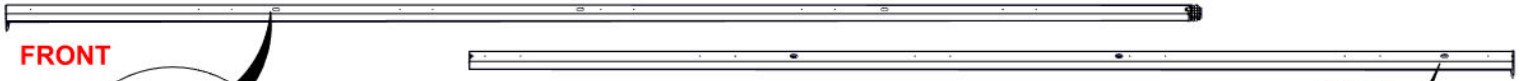

FRONT

BACK

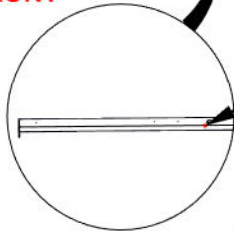

NOTE THIS HOLE FOR ORIENTATION

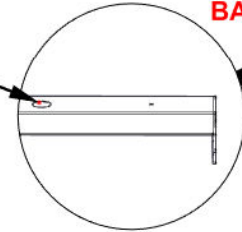

NOTE THIS HOLE FOR ORIENTATION

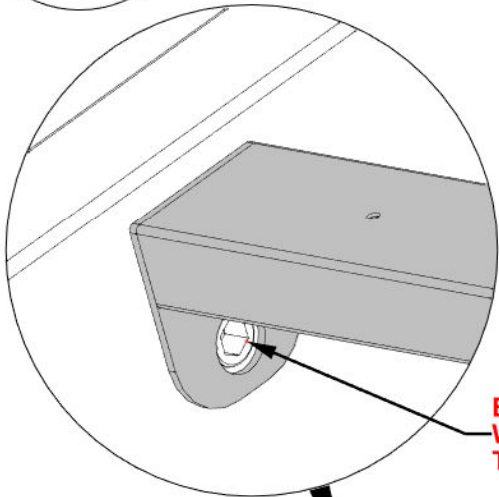

1132 (x56)
TORX SOCKET
SCREW SHORT 1/4-20
HAND TIGHTEN ONLY

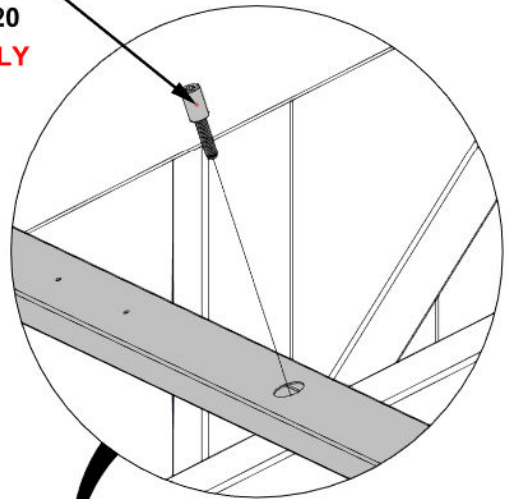

BRACKET HOLES
WILL FIT AROUND
THREADED INSERTS

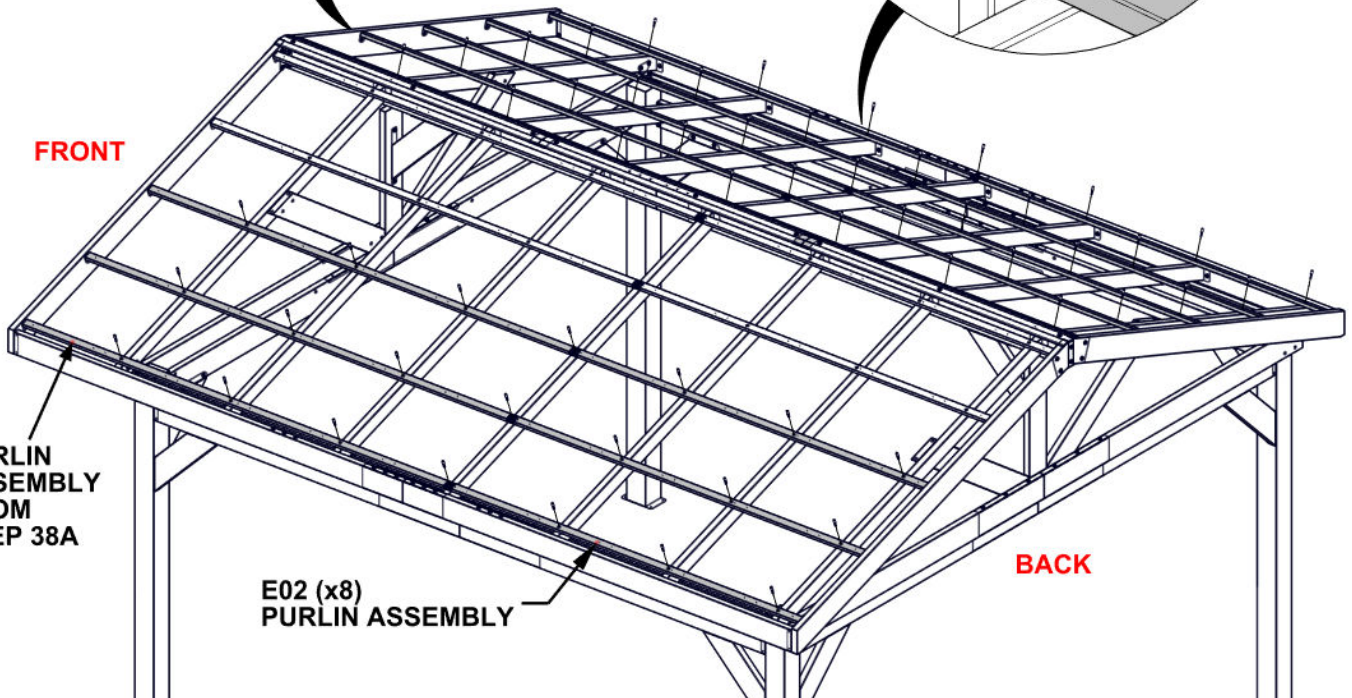

FRONT

BACK

PURLIN ASSEMBLY FROM STEP 38A

E02 (x8) PURLIN ASSEMBLY

STEP 38E - ROOF ASSEMBLY

Qty	PartNo	Description
20	H101202	TORX PAN HEAD 1/4-20x3/4 ASSY

- ONCE PURLINS HAVE BEEN INSTALLED,
TIGHTEN ALL HARDWARE FROM PREVIOUS STEPS.

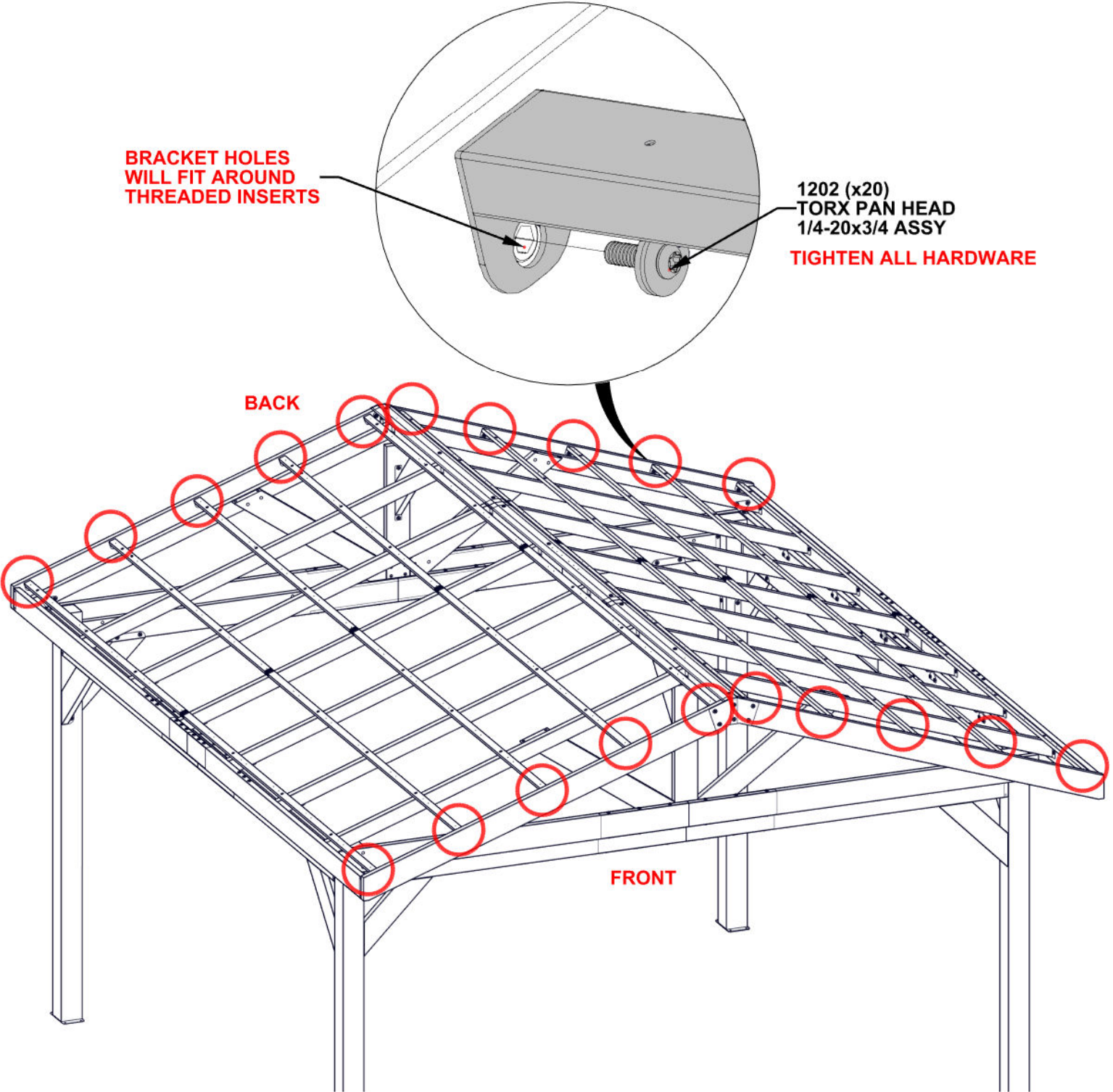

STEP 39 - ROOF ASSEMBLY

Qty	PartNo	Description
8	H101117	SCREW WOODGRIP 10-16x3/4" BLK

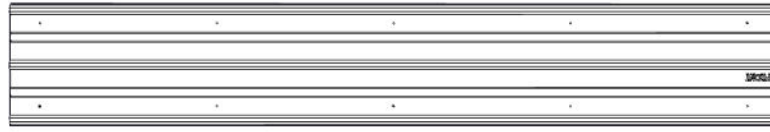

A4M04426 STEEL SHEETING
(x1)

- WARNING: GLOVES ARE RECOMMENDED WHEN HANDLING STEEL ROOF PIECES.

- REMOVE PROTECTIVE FILM.
- SLIDE ROOF SHEET UP, MAKING SURE IT SLIDES UNDERNEATH THE RIDGE CAP.
- STARTING AT THE LEFT SIDE AND WORKING TO THE RIGHT, LINE UP THE HOLES IN THE ROOF SHEET WITH THE PILOT HOLES IN THE PURLINS.

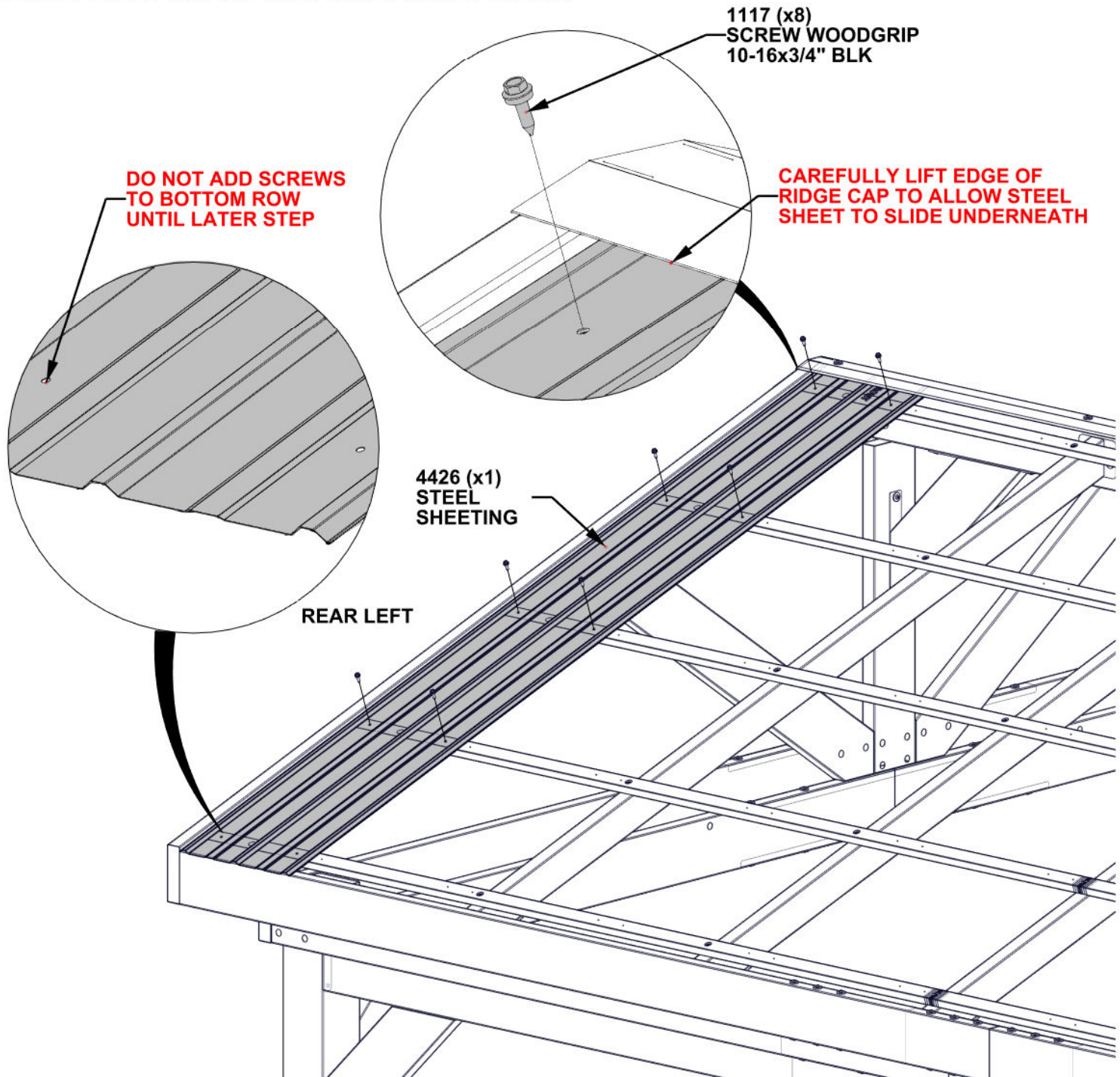

STEP 40 - ROOF ASSEMBLY

Qty	PartNo	Description
8	H101117	SCREW WOODGRIP 10-16x3/4" BLK



A4M03528 STEEL SHEETING
(x1)

- WARNING: GLOVES ARE RECOMMENDED WHEN HANDLING STEEL ROOF PIECES.

- REMOVE PROTECTIVE FILM.
- SLIDE ROOF SHEET UP, MAKING SURE IT SLIDES UNDERNEATH THE RIDGE CAP.
- STARTING AT THE LEFT SIDE AND WORKING TO THE RIGHT, LINE UP THE HOLES IN THE ROOF SHEET WITH THE PILOT HOLES IN THE PURLINS.

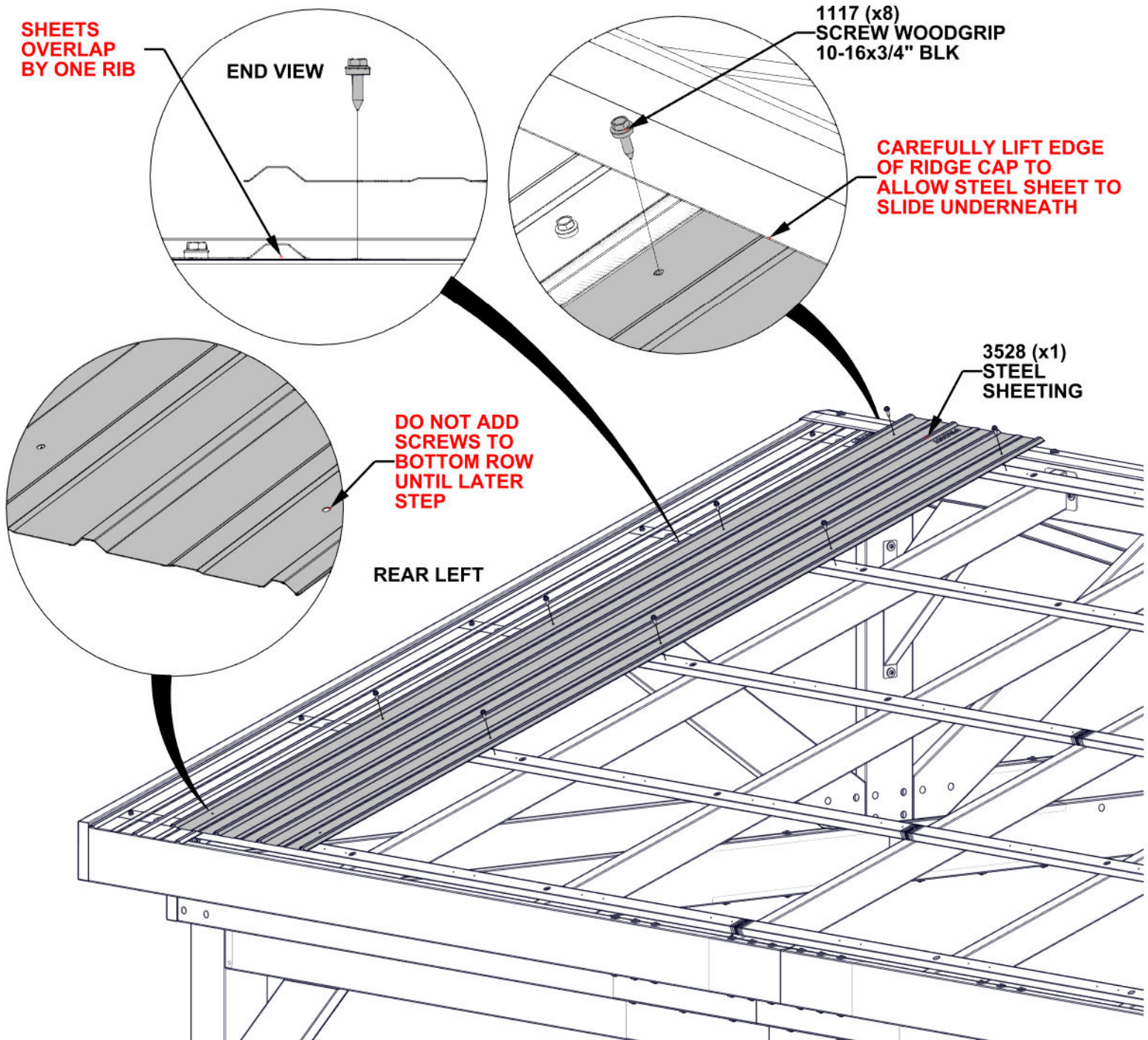

STEP 41 - ROOF ASSEMBLY

Qty	PartNo	Description
72	H101117	SCREW WOODGRIP 10-16x3/4" BLK

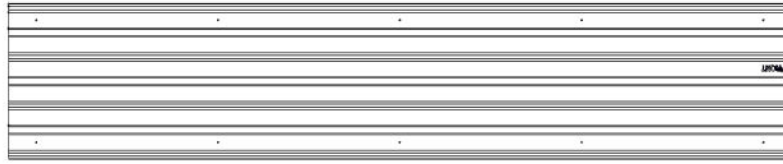

A4M03528 STEEL SHEETING
(x9)

- **WARNING: GLOVES ARE RECOMMENDED WHEN HANDLING STEEL ROOF PIECES.**
- REMOVE PROTECTIVE FILM.
- REPEAT PREVIOUS STEP FOR REMAINDER OF LEFT SIDE.
- ATTACH AND FULLY TIGHTEN ALL SCREWS ON EACH ROOF SHEET BEFORE ATTACHING THE NEXT ONE.

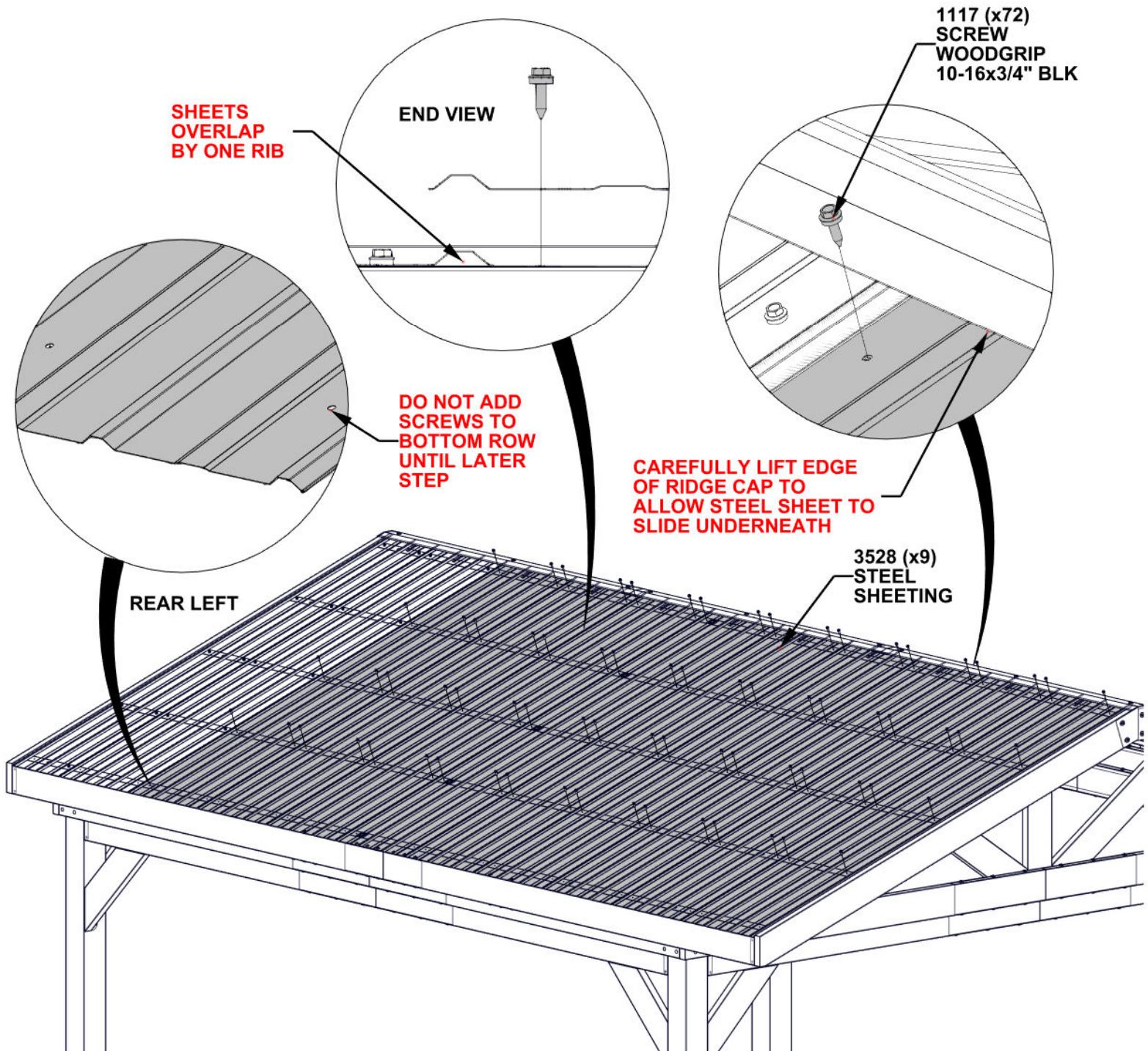

STEP 42 - ROOF ASSEMBLY

Qty	PartNo	Description
8	H101116	SCREW SELF TAPPING 1/4x1 BLK

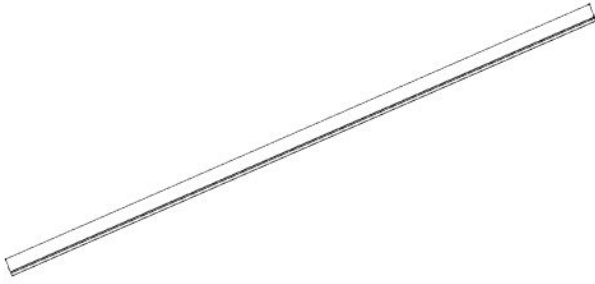

A4M03532 EDGE TRIM
(x2)

- DUE TO MULTIPLE LAYERS OF METAL ON THE DRIP EDGE, IT IS RECOMMENDED THAT A 1/8" (3mm) DRILL BIT BE USED TO CREATE STARTER HOLES.
- WARNING: GLOVES ARE RECOMMENDED WHEN HANDLING STEEL ROOF PIECES.
- REMOVE PROTECTIVE FILM.
- SLIDE EDGE TRIM UNTIL ONE END IS POSITIONED UNDERNEATH RIDGE CAP AND OTHER END IS FLUSH WITH END.
- STARTING AT THE TOP, ALIGN SCREWS WITH SHEET SCREWS.

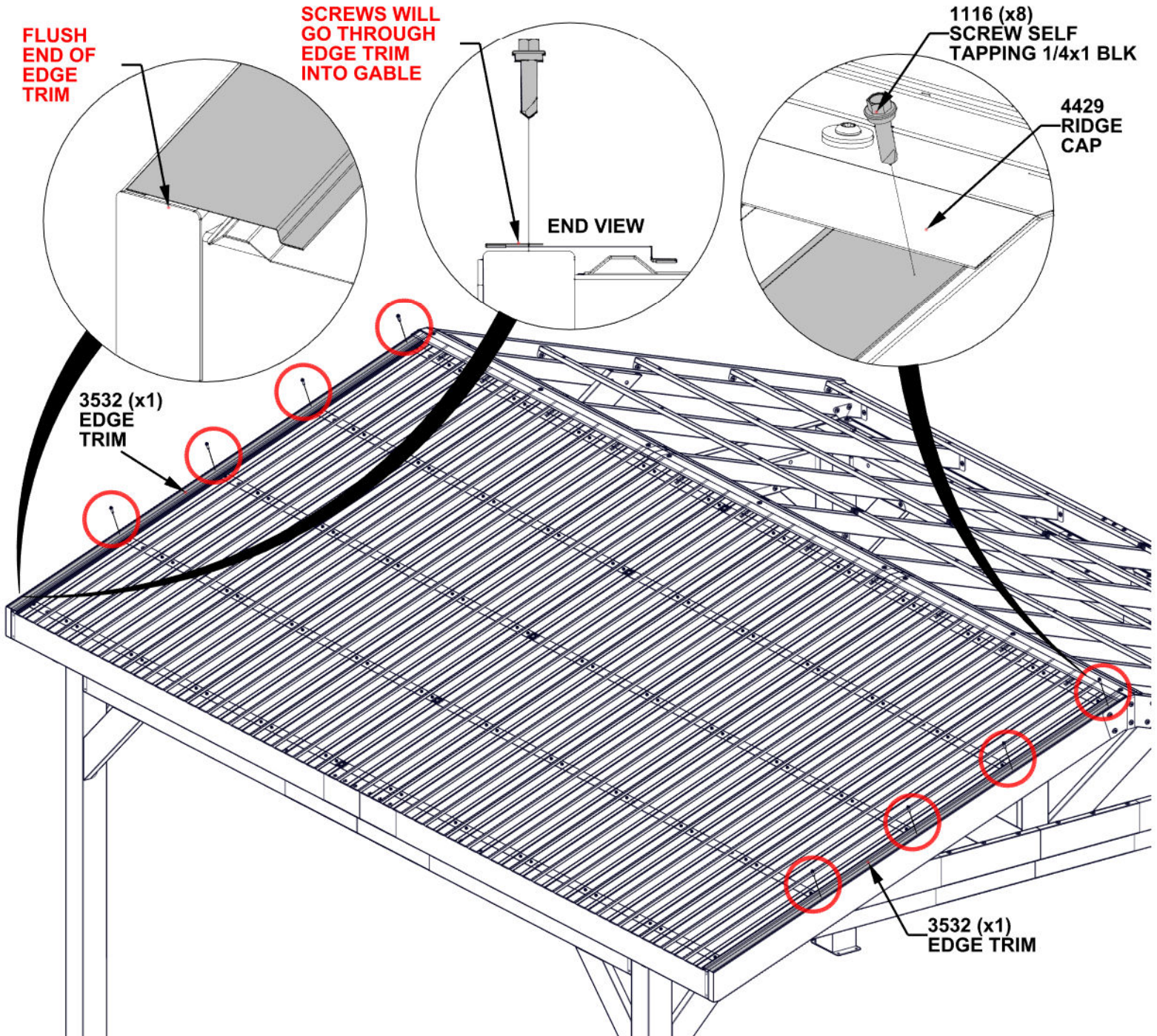

STEP 43A - ROOF ASSEMBLY

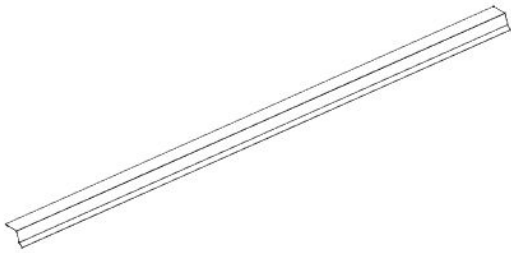

A4M04427 DRIP TRIM
(x3)

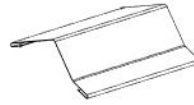

A4M05365 DRIP TRIM SPLICE
(x2)

- REMOVE PROTECTIVE FILM.
- WITH ONE EXTRA PERSON, ORIENT DRIP TRIMS AND DRIP TRIM SPLICES UNDER ALL STEEL SHEETINGS.

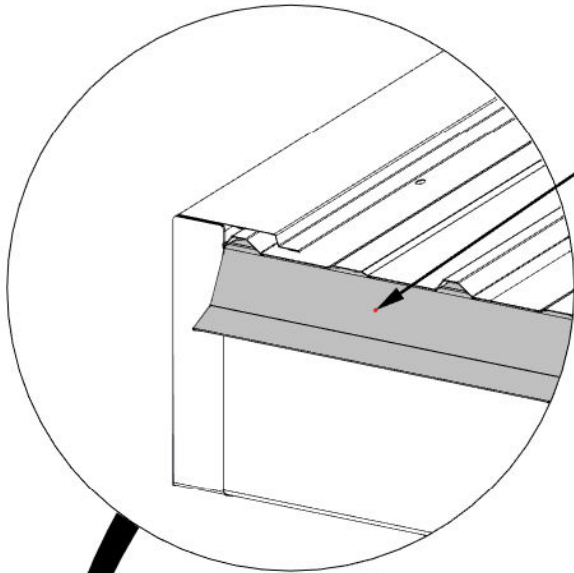

**ALL DRIP TRIMS AND SPLICES
MUST BE UNDER STEEL SHEETING.**

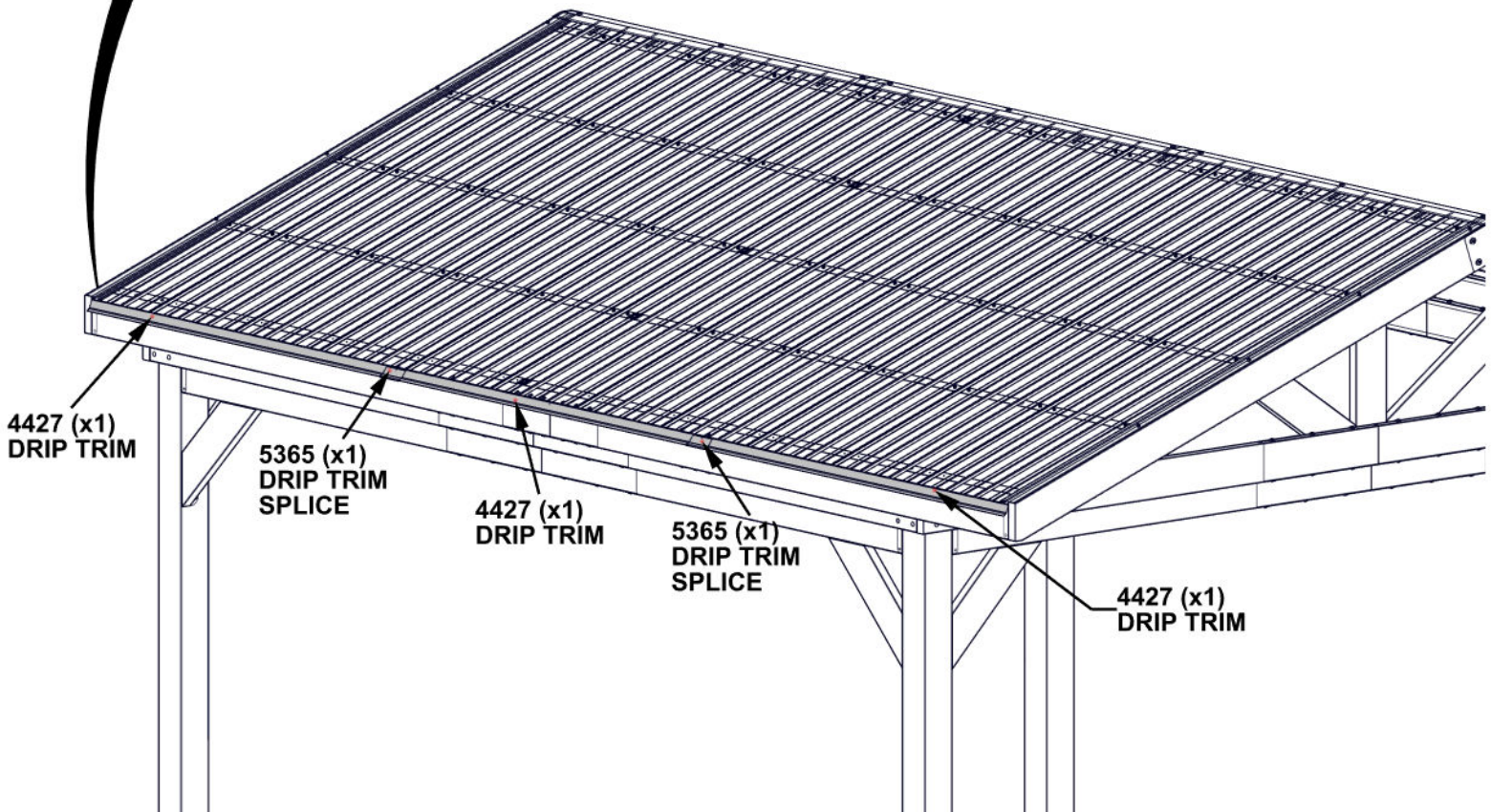

STEP 43B - ROOF ASSEMBLY

Qty	PartNo	Description
18	H101116	SCREW SELF TAPPING 1/4x1 BLK

- DUE TO MULTIPLE LAYERS OF METAL ON THE DRIP EDGE, IT IS RECOMMENDED THAT A 1/8" (3mm) DRILL BIT BE USED TO CREATE STARTER HOLES.
- WARNING: GLOVES ARE RECOMMENDED WHEN HANDLING STEEL ROOF PIECES.
- STARTING IN THE FRONT CORNER, ATTACH SCREWS SPACING EVERY OTHER RIB.

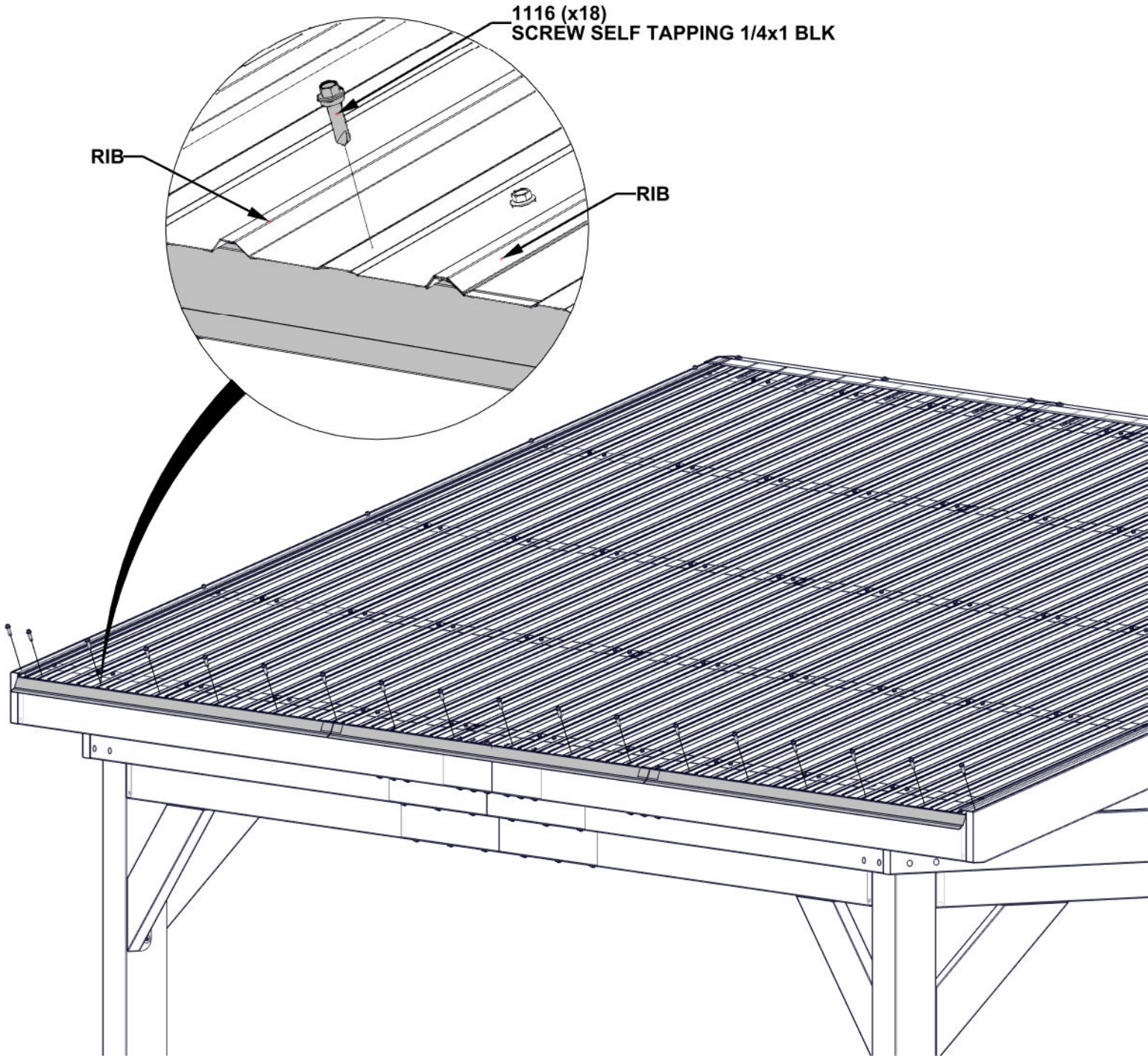

STEP 43C - ROOF ASSEMBLY

Qty	PartNo	Description
22	H101117	SCREW WOODGRIP 10-16x3/4" BLK

- ADD SCREWS TO THE BOTTOM ROW AND TIGHTEN ALL HARDWARE.

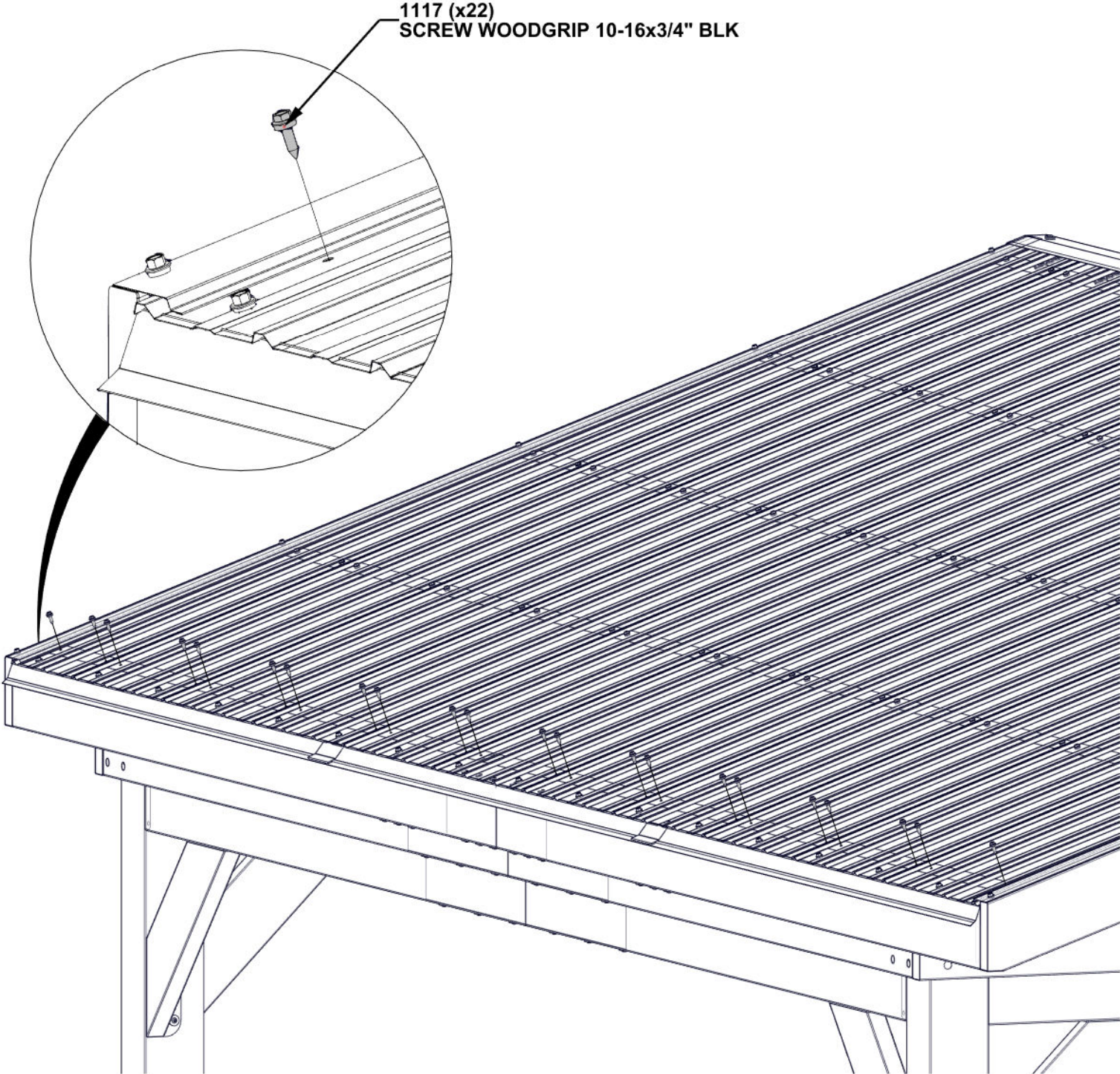

**REPEAT ROOF ASSEMBLY STEPS 39 - 43C
TO INSTALL SHEETMETAL ON OPPOSITE SIDE OF ROOF**

STEP 44 - STRUCTURE ASSEMBLY

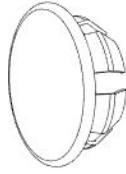

A4M01352 HOLE COVER
(x72)

- USE A SMALL PIECE OF WOOD AND RUBBER Mallet TO TAP HOLE COVERS IN.
- DO NOT TAP DIRECTLY WITH A HAMMER AS YOU MAY DAMAGE THE POWDER COAT FINISH ON PRODUCT.

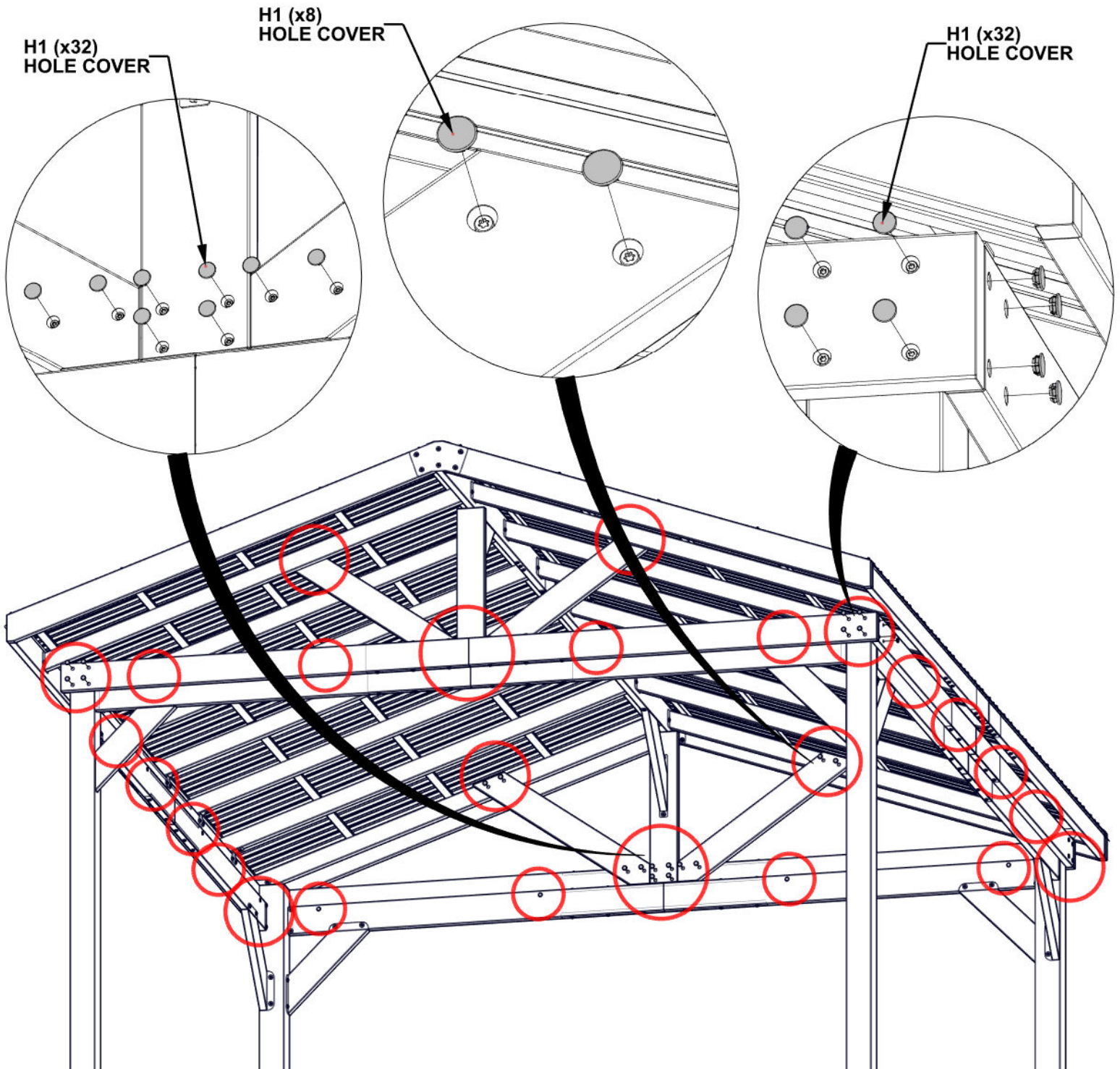

STEP 45 - PERGOLA ANCHORING

Qty	PartNo	Description
16	H100630	WASHER FLAT 8x19 BLK
16	H100120	CONCRETE ANCHOR

- MANUFACTURER RECOMMENDS INSTALLATION ON CONCRETE SURFACE OR CONCRETE POST PADS. SEE BELOW.
- FOR INSTALLATION ON WOOD DECKS, YOU MUST ENSURE THERE IS AMPLE STRUCTURAL SUPPORT UNDER DECK.
- REPEAT THIS STEP FOR ALL FOUR POST.

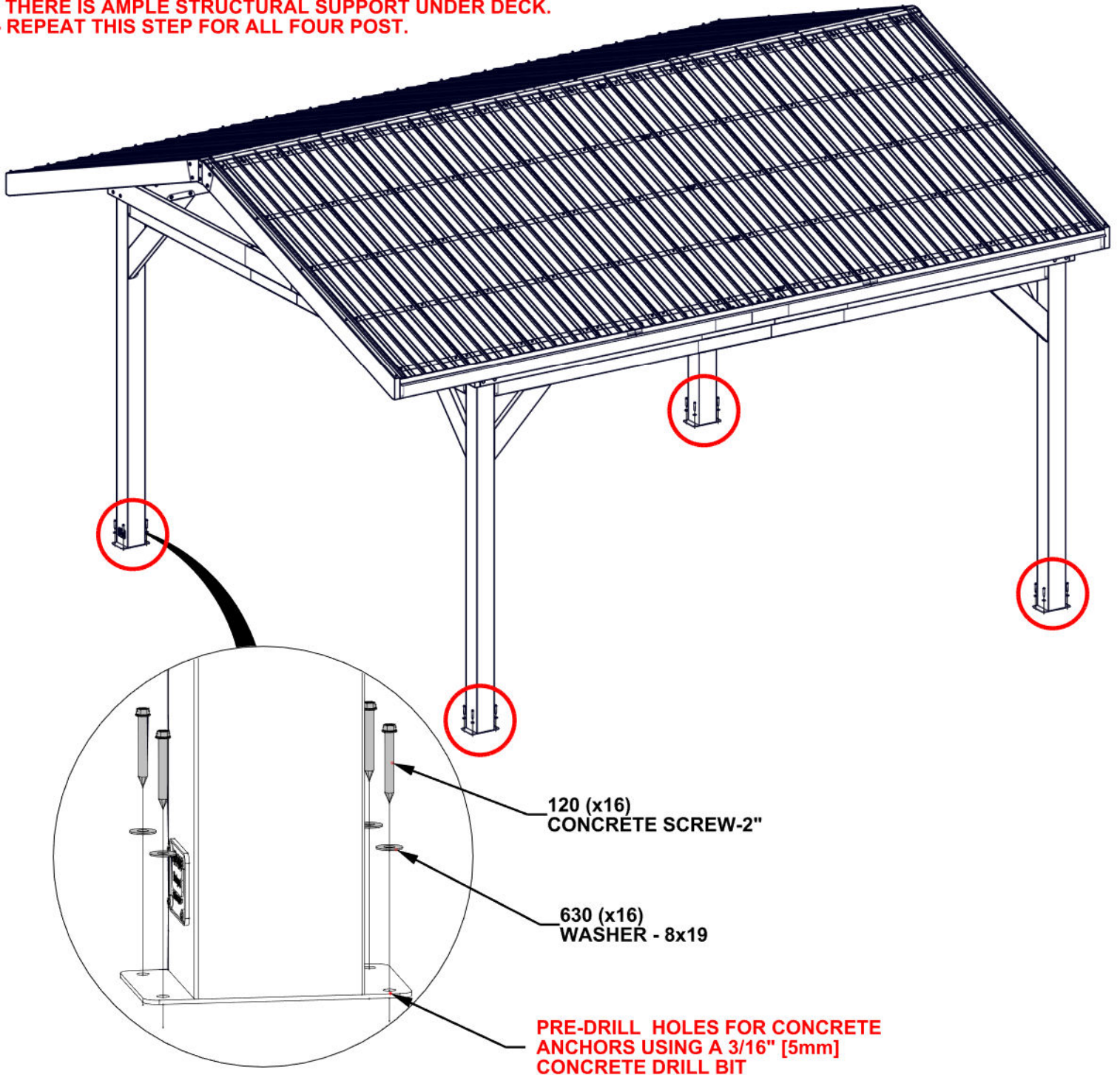

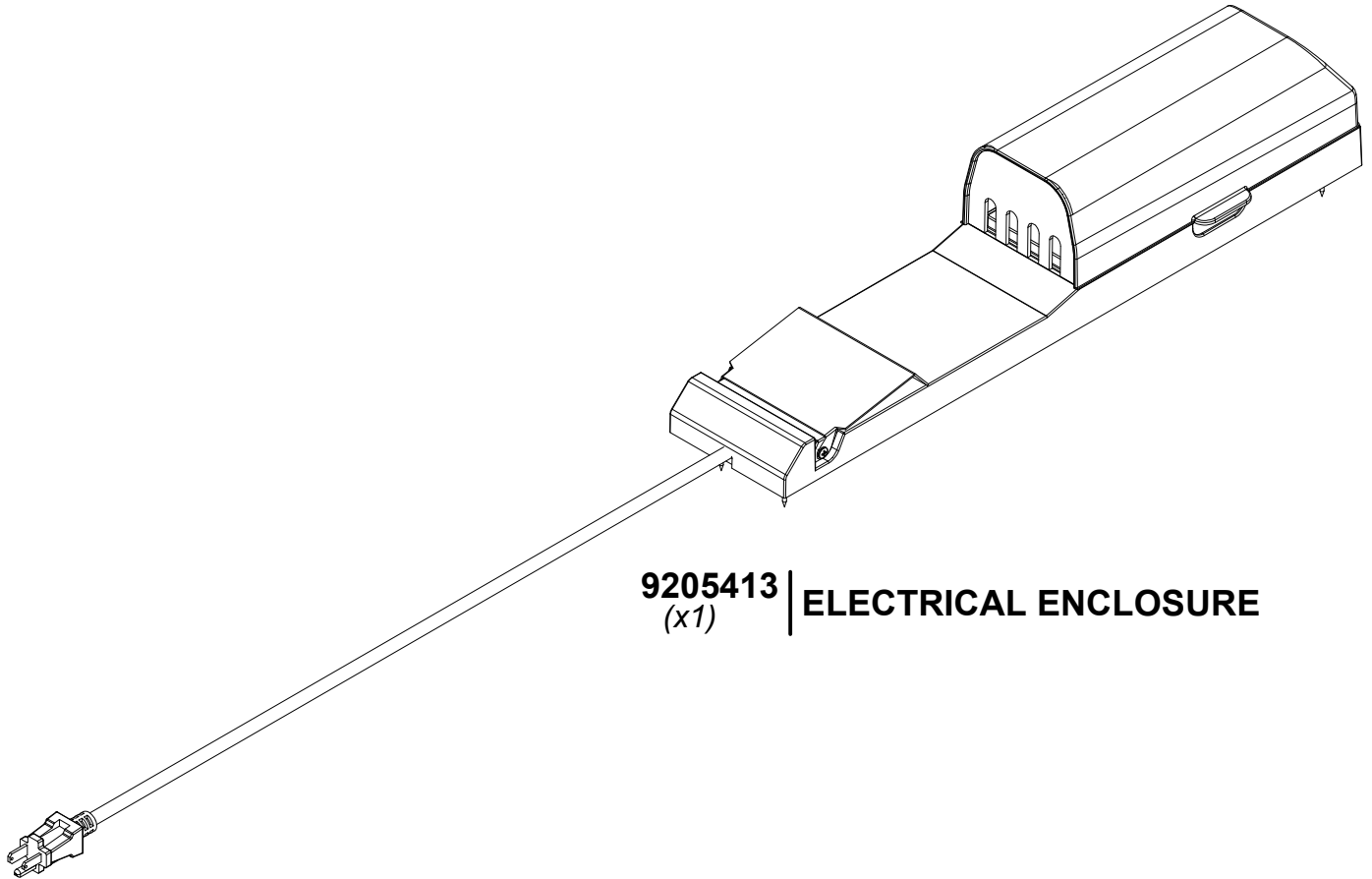

9205413 | **ELECTRICAL ENCLOSURE**
(x1)

FOR POWERPORT INSTALLATION REFER TO ASSEMBLY INSTRUCTIONS THAT COME PACKAGED WITH THE POWERPORT KIT. INSTALL ON ANY EXTERIOR POST THAT IS DESIRED. FOLLOW DIRECTIONS FOR PROPER INSTALLATION.