



Manufactured by:
Backyard Discovery
3305 Airport Drive, Pittsburg, KS 66762
800-856-4445

Basepoint Business Centre: Rivermead Drive, Westlea, Swindon SN5 7EX Phone: 0800-118-2476 J.P. Coenstraat 7, The Bridge, The Hague, 2595 WP, Netherlands Phone: 08005678990

16X14 LANCASTER GAZEBO GUTTER KIT MODEL #: 9250376



Please visit www.backyarddiscovery.com
For the most up to date assembly manual, to register your product, or to order
replacement parts Para obtener instrucciones en español, visite
www.backyarddiscovery.com

OWNER'S MANUAL - PARTS IDENTIFICATION

Hardware Components



H101414 SCREW SELF PIERCING #8x1/2 BLK
(x10) #8 x 1/2

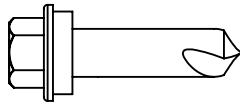

H101480 SCREW SELF TAPPING #9x1 BLK
(x26) 1/4 x 1



A6P01531 10 OZ SILICONE TUBE
(x1)

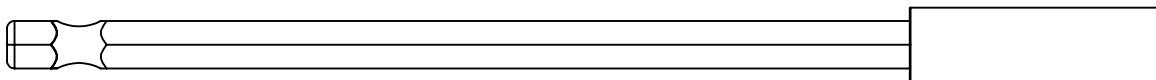

H101278 6" MAGNETIC DRIVER EXTENSION
(x1)

OWNER'S MANUAL - PARTS IDENTIFICATION

Hardware Components

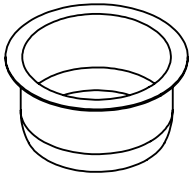

A4M04761 DOWNSPOUT OUTLET
(x2) 1 7/16"x2 7/8" [37x73]

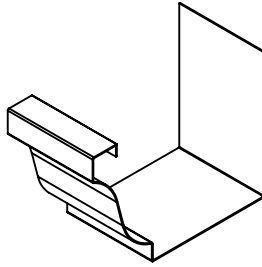

A4M04765 GUTTER SPLICE
(x2) 2 1/2"x3 11/16"x5 1/16" [64x94x129]

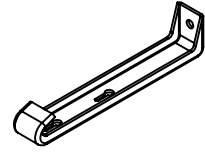

A4M04759 GUTTER HANGER
(x18) 3/4"x1"x4 15/16" [19x25x125]

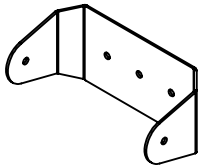

A4M04782 DOWNSPOUT CLIP
(x4) 1 7/16"x1 7/16"x3 1/8" [37x37x79]

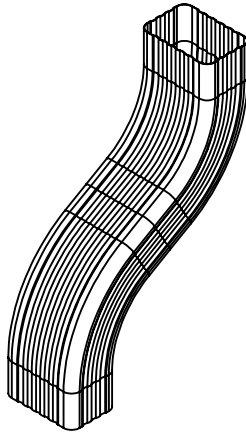

A4M06693 DOWNSPOUT OFFSET - 6"
(x2) 3"x8"x6 7/8" [76x175x203]

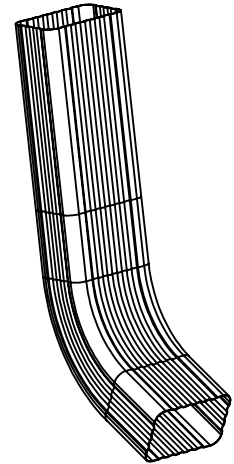

A4M06238 LONG DOWNSPOUT ELBOW
(x2) 3"x10 5/8"x10 11/16" [76x270x271]

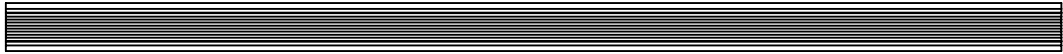

A4M06685 DOWNSPOUT - 66"
(x2) 2"x3"x66" [51x76x1675]

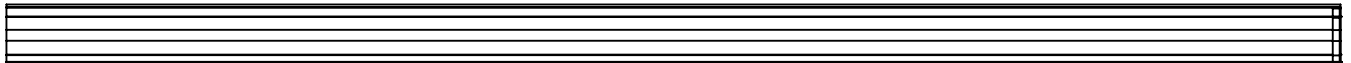

A4M06895 GUTTER
(x1) 3 11/16"x5 1/8"x95 3/16" [94x130x2418]

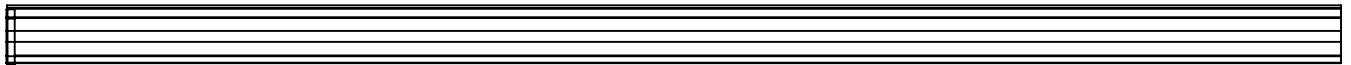

A4M06896 GUTTER W/ OUTLET
(x1) 3 11/16"x5 1/8"x95 3/16" [94x130x2418]

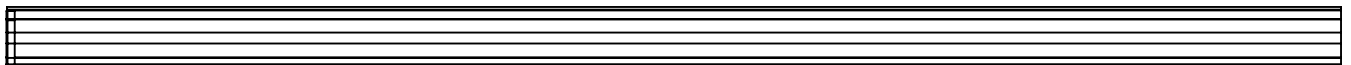

A4M06897 GUTTER W/ OUTLET
(x1) 3 11/16"x5 1/8"x95 3/16" [94x130x2418]

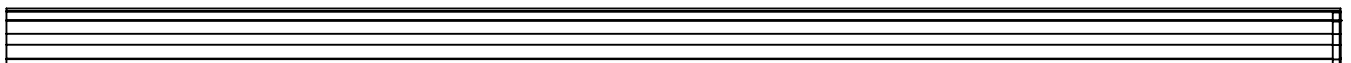

A4M06898 GUTTER
(x1) 3 11/16"x5 1/8"x95 3/16" [94x130x2418]

PRE-ASSEMBLY STEP 1 - SORTING PARTS

It is critical for ease of assembly that you take the time to sort and organize the parts and hardware.

HARDWARE PARTS:

- We recommend that you have a separate table to organize the hardware.
- Hardware bags are printed with a seven-digit, alpha-numeric part number.
- You can organize your hardware by part number or group by hardware type (e.g. bolts, nuts, etc.).
- During assembly you only need to reference the last four digits of the number.



TOOLS REQUIRED:



Cordless Drill or
Electric Drill



1/8" Drill Bit



Tape Measure



Caulk Gun

OFFSET ORIENTATION

TO ENSURE WATER FLOWS PROPERLY, IT IS IMPORTANT TO ORIENT DOWNSPOUT PIPING CORRECTLY. STARTING AT THE TOP, DOWNSPOUTS MUST FEED INTO THE NEXT SECTION AS SHOWN.



IF PIPING IS REVERSED, WATER WILL RUN OUT OF GAPS AROUND JOINTS



GUTTER SPLICE PAGE

- NOTE:**
- APPLY SILICONE TO INSIDE CHANNEL ON BOTH SIDES.
 - ENSURE SILICONE IS EVENLY APPLIED ALONG THE CHANNEL.
 - AFTER GUTTER SPLICE HAS BEEN SLID ONTO GUTTERS AND SILICONE HAS HAD TIME TO CURE, USING HAND PRESSURE ONLY, FOLD THE TOP TAB OVER EDGE OF GUTTER

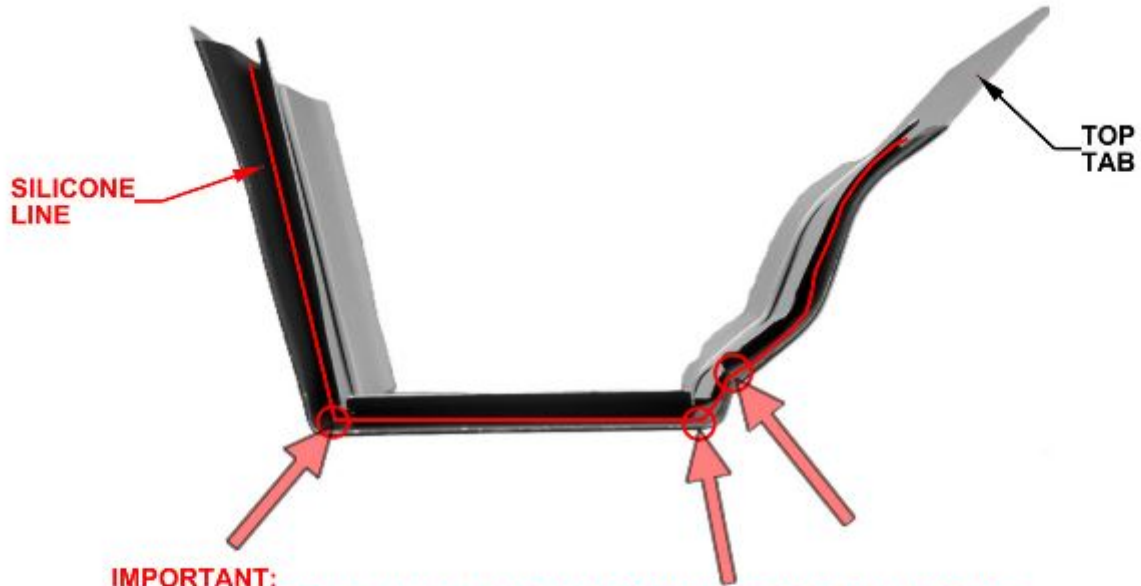

- IMPORTANT:**
- APPLY SILICONE LIBERALLY INTO CORNERS AS INDICATED ABOVE.

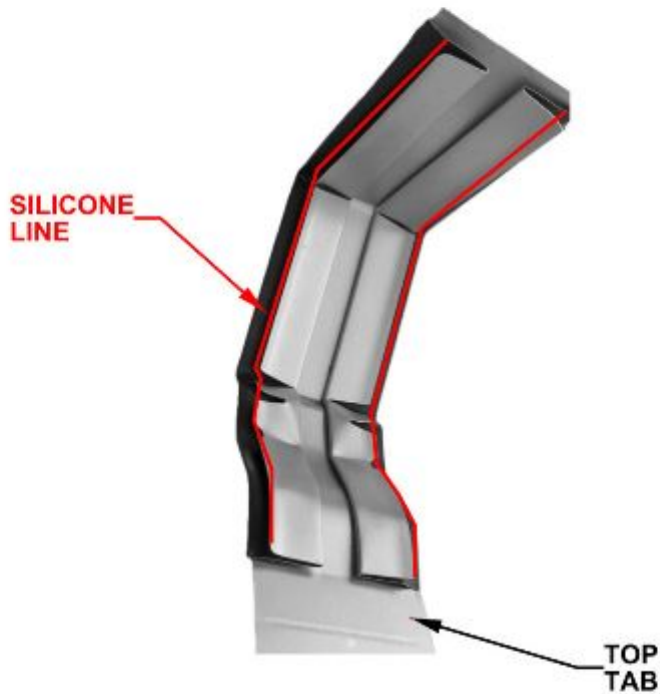

WAIT APPROXIMATELY 45 MINUTES FOR SILICONE TO BE COME TACKY.
AFTER 24 HOURS, SILICONE HAS CURED AND CAN HOLD WATER

STEP 1 - GUTTER ASSEMBLY

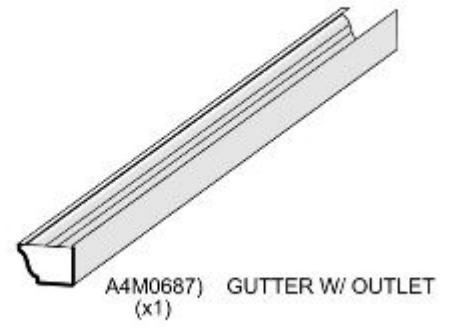
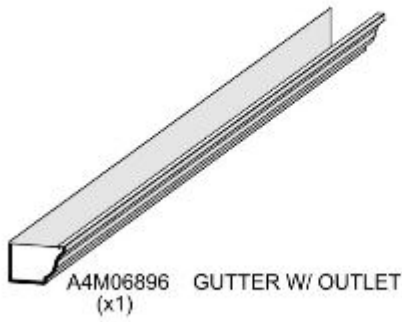

- APPLY A BEAD OF SILICONE AROUND THE BOTTOM LIP OF THE DOWNSPOUT OUTLET AND PLACE OUTLET INSIDE GUTTER.

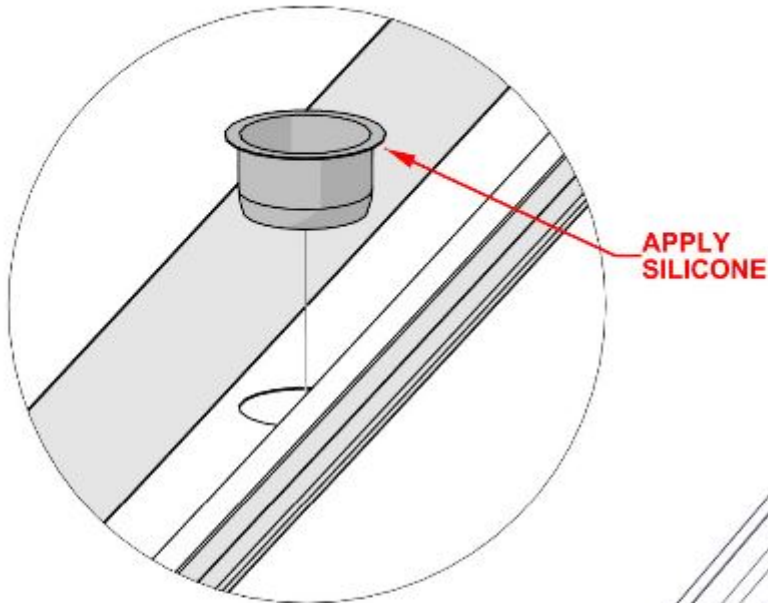

TIP: PRESSURE MAY NEED TO BE APPLIED TO GET OUTLET INTO POSITION. USE A WET FINGER TO FLATTEN SILICONE AFTER INSTALL.

4761 (x2)
DOWNSPOUT OUTLET

6897 (x1)
GUTTER W/ OUTLET

6896 (x1)
GUTTER W/ OUTLET

STEP 2 - GUTTER ASSEMBLY

LAY GUTTERS AROUND STRUCTURE AS SHOWN TO VERIFY CORRECT INSTALLATION.

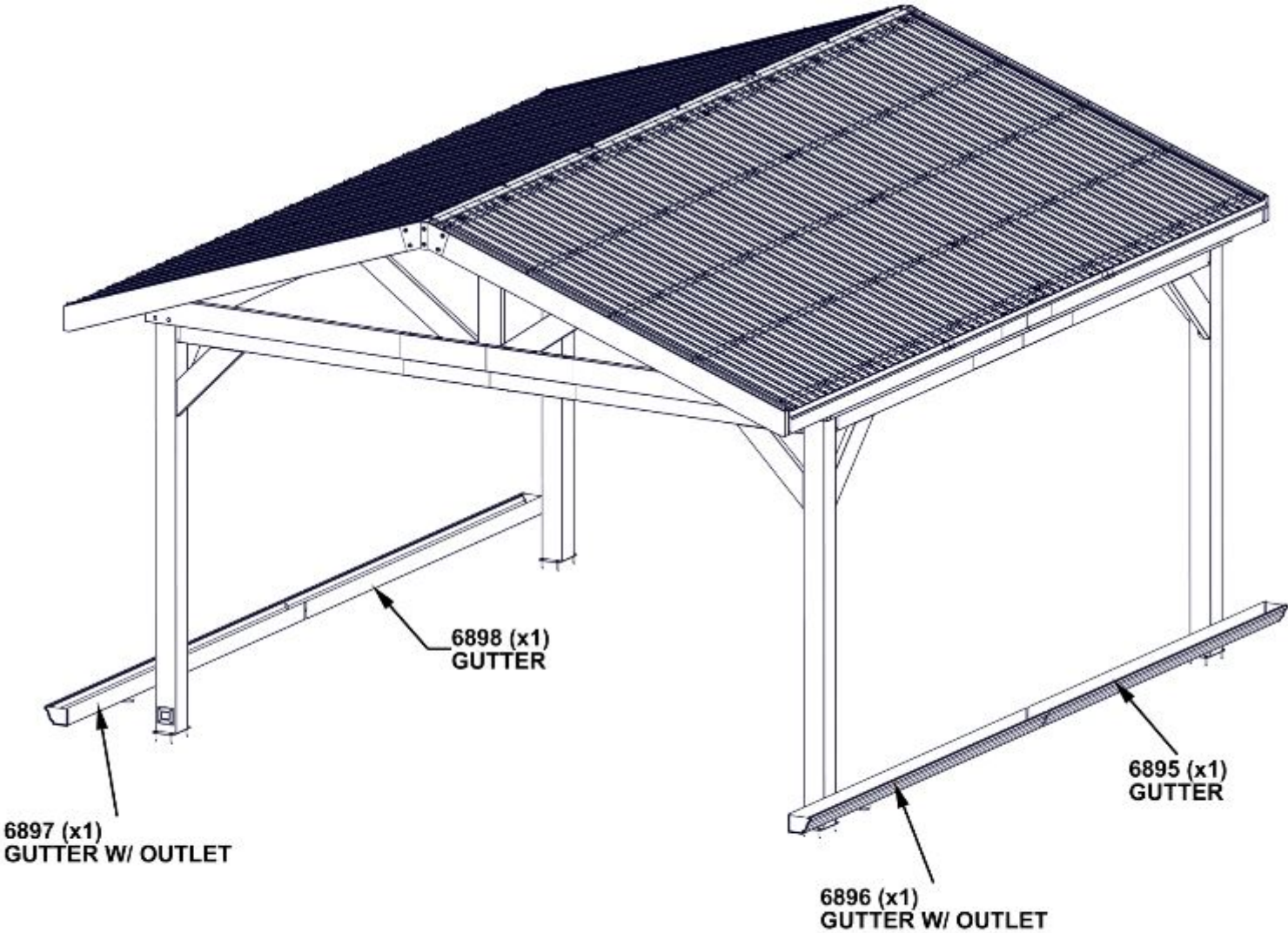

STEP 3 - GUTTER ASSEMBLY

QTY	PART NUMBER	DESCRIPTION
2	H101480	SCREW SELF TAPPING #9x1 BLK

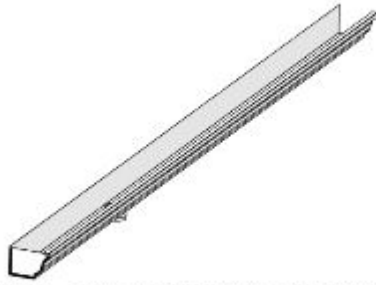

A4M06896 GUTTER W/ OUTLET ASSEMBLY

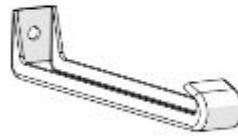

A4M04759 GUTTER HANGER (x2)

- SLIDE GUTTER BEHIND EDGE TRIM AND UP TO ROOF METAL.
- FLUSH INSIDE OF GUTTER WITH INSIDE OF FASCIA BOARD.
- ATTACH THE FIRST HANGER APPROXIMATELY 5" [125mm] FROM THE EDGE.
- ATTACH THE SECOND HANGER AT THE 13TH ROOF RIB.
- USE A CLAMP TO HOLD THE GUTTER TO THE BOARD FOR ASSISTANCE.
- PRE-DRILL 1/8" [3mm] PILOT HOLES FOR EASE OF ASSEMBLY.

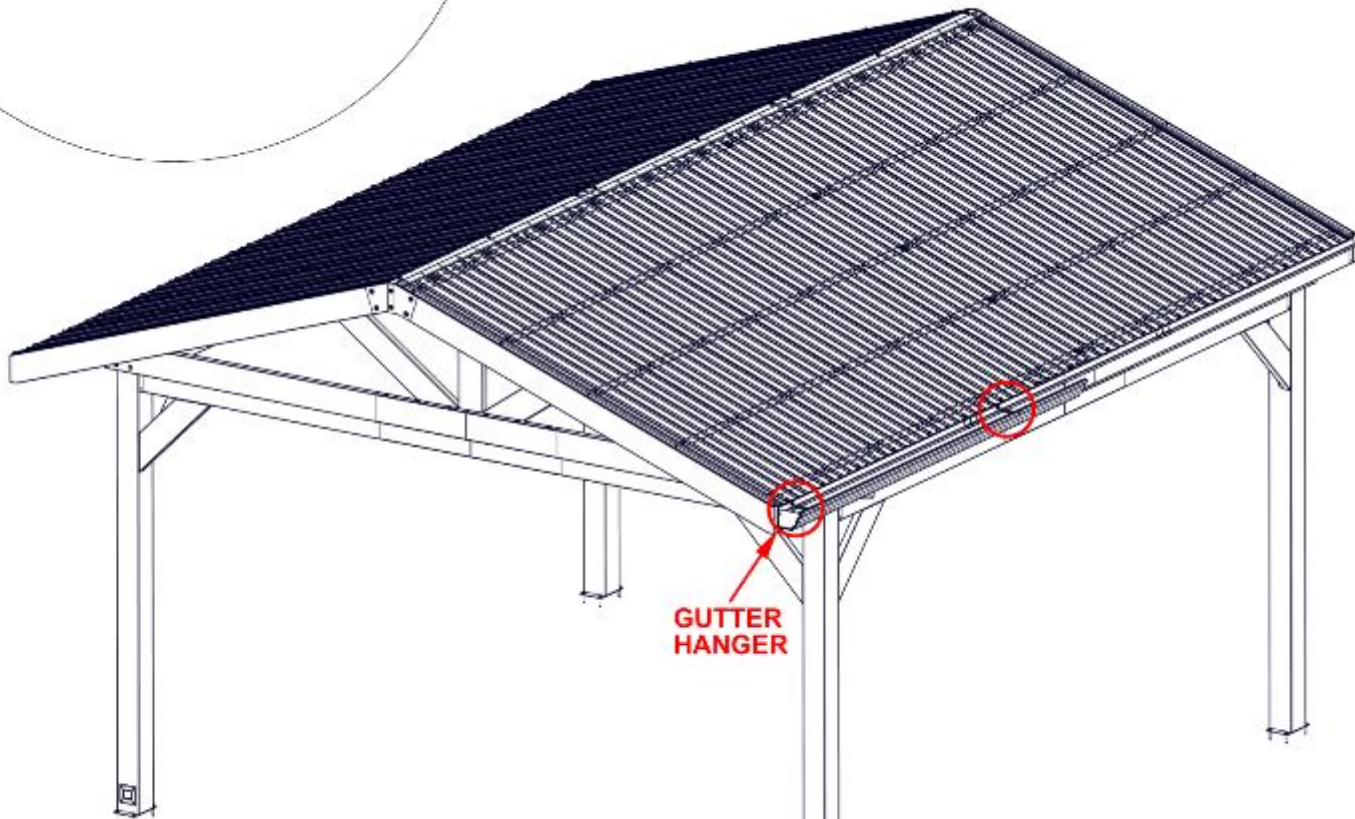
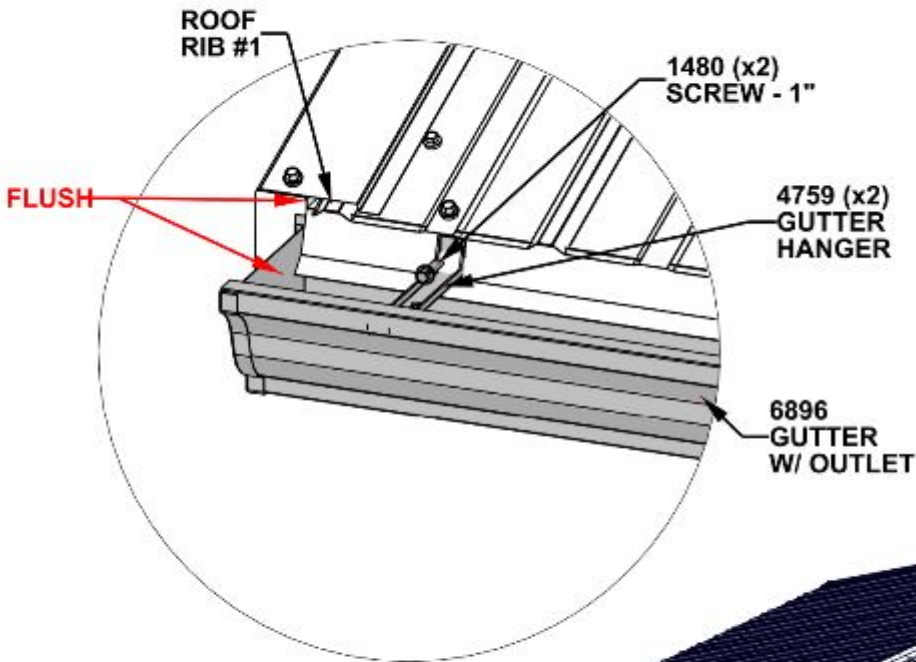

STEP 4 - GUTTER ASSEMBLY

QTY	PART NUMBER	DESCRIPTION
2	H101480	SCREW SELF TAPPING #9x1 BLK

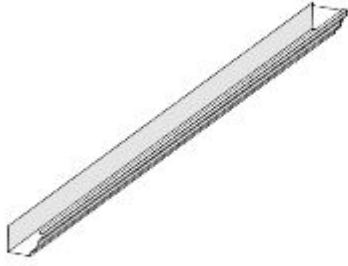

A4M06895 GUTTER
(x1)

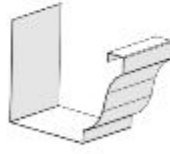

A4M04765 GUTTER SPLICE
(x1)



A4M04759 GUTTER HANGER
(x2)

- SLIDE GUTTER BEHIND EDGE TRIM AND UP TO ROOF METAL.
- FLUSH INSIDE OF GUTTER WITH INSIDE OF FASCIA BOARD.
- ATTACH THE FIRST HANGER APPROXIMATELY 5" [125mm] FROM THE EDGE.
- ATTACH THE SECOND HANGER AT THE 13TH ROOF RIB.
- USE A CLAMP TO HOLD THE GUTTER TO THE BOARD FOR ASSISTANCE.
- PRE-DRILL 1/8" [3mm] PILOT HOLES FOR EASE OF ASSEMBLY.

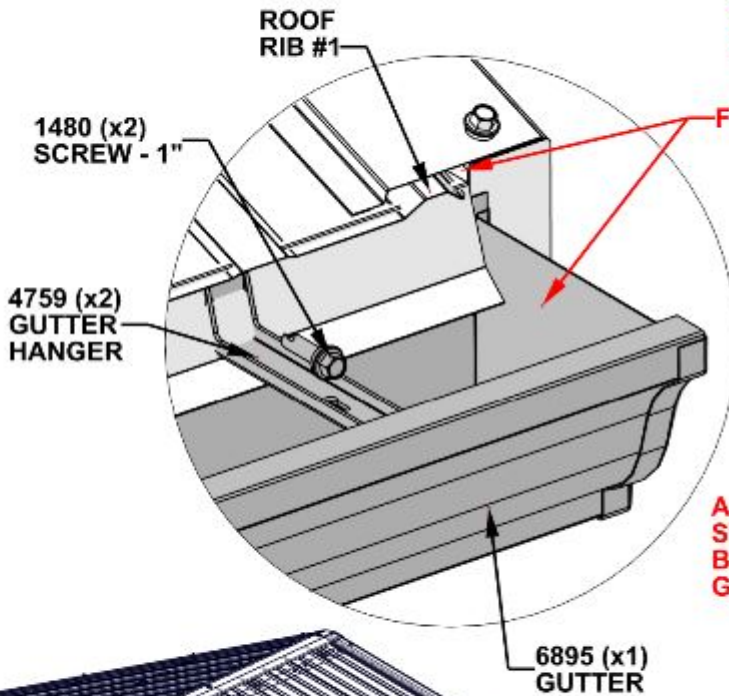

APPLY SILICONE TO SPLICE GROOVE BEFORE INSERTING INTO GUTTER

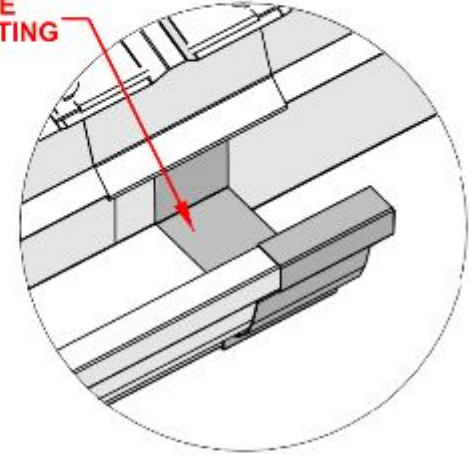

APPLY SILICONE TO SPLICE GROOVE BEFORE INSERTING GUTTER INTO SPLICE

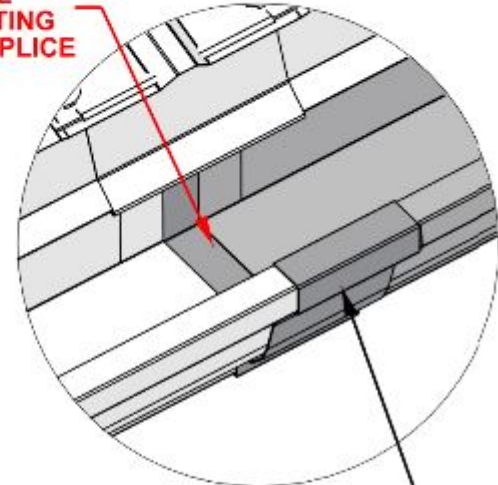

4765 (x1) GUTTER SPLICE

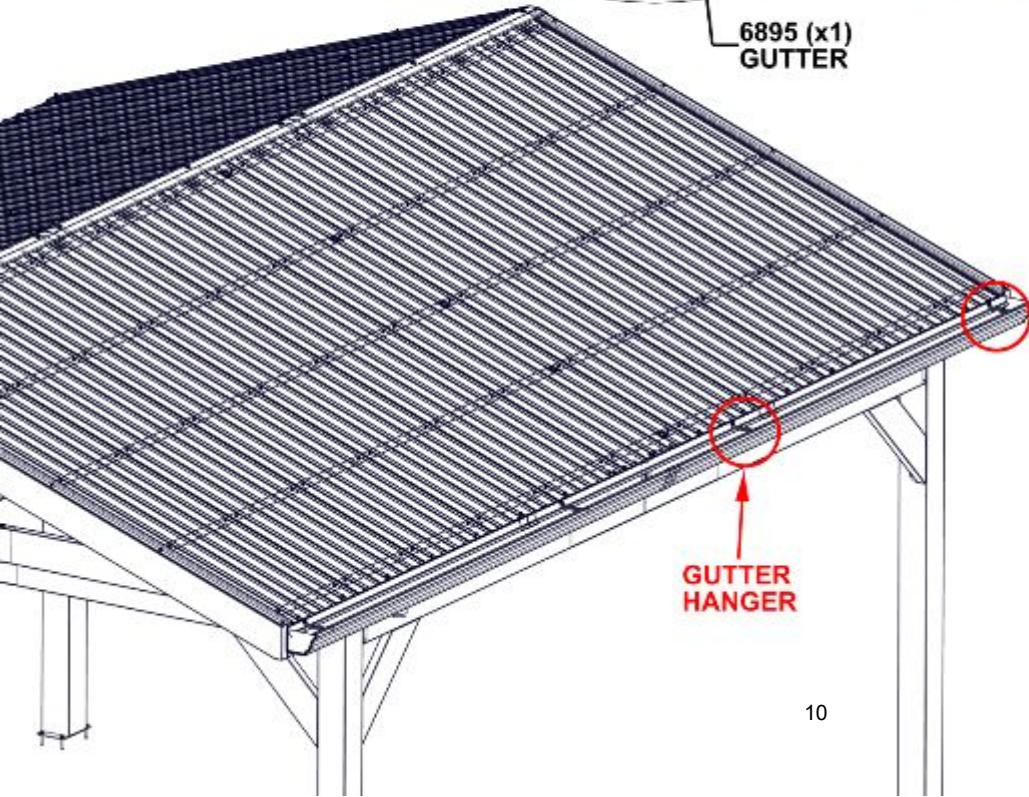

STEP 5 - GUTTER ASSEMBLY

QTY	PART NUMBER	DESCRIPTION
2	H101480	SCREW SELF TAPPING #9x1 BLK

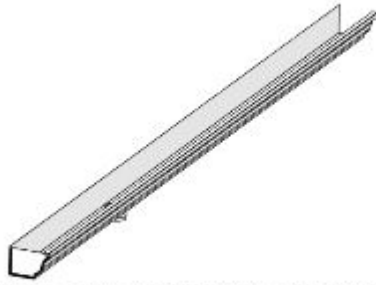

A4M06897 GUTTER W/ OUTLET ASSEMBLY

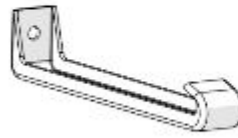

A4M04759 GUTTER HANGER (x2)

- SLIDE GUTTER BEHIND EDGE TRIM AND UP TO ROOF METAL.
- FLUSH INSIDE OF GUTTER WITH INSIDE OF FASCIA BOARD.
- ATTACH THE FIRST HANGER APPROXIMATELY 5" [125mm] FROM THE EDGE.
- ATTACH THE SECOND HANGER AT THE 13TH ROOF RIB.
- USE A CLAMP TO HOLD THE GUTTER TO THE BOARD FOR ASSISTANCE.
- PRE-DRILL 1/8" [3mm] PILOT HOLES FOR EASE OF ASSEMBLY.

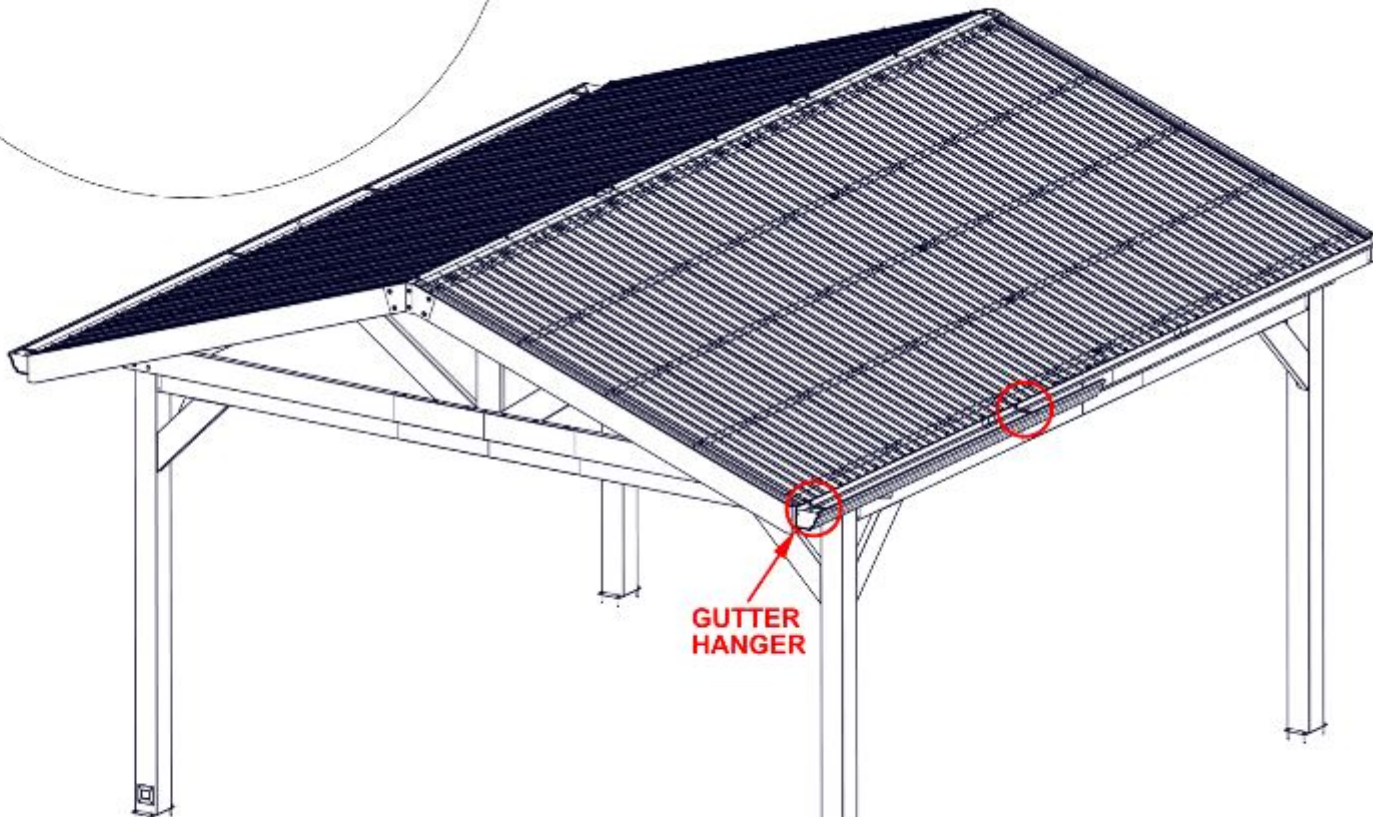
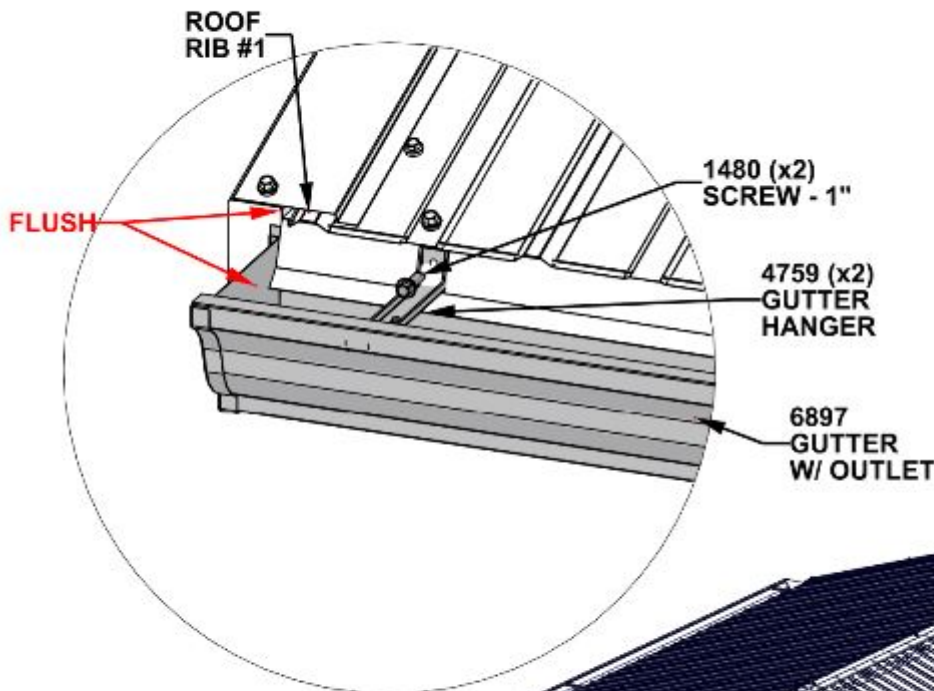

STEP 6 - GUTTER ASSEMBLY

QTY	PART NUMBER	DESCRIPTION
2	H101480	SCREW SELF TAPPING #9x1 BLK

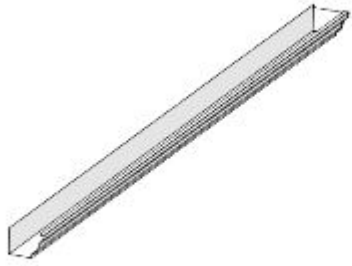

A4M06898 GUTTER (x1)

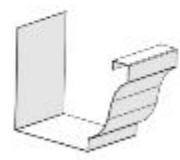

A4M04765 GUTTER SPLICE (x1)

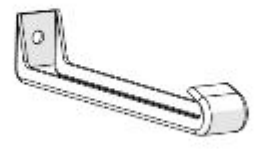

A4M04759 GUTTER HANGER (x2)

- SLIDE GUTTER BEHIND EDGE TRIM AND UP TO ROOF METAL.
- FLUSH INSIDE OF GUTTER WITH INSIDE OF FASCIA BOARD.
- ATTACH THE FIRST HANGER APPROXIMATELY 5" [125mm] FROM THE EDGE.
- ATTACH THE SECOND HANGER AT THE 13TH ROOF RIB.
- USE A CLAMP TO HOLD THE GUTTER TO THE BOARD FOR ASSISTANCE.
- PRE-DRILL 1/8" [3mm] PILOT HOLES FOR EASE OF ASSEMBLY.

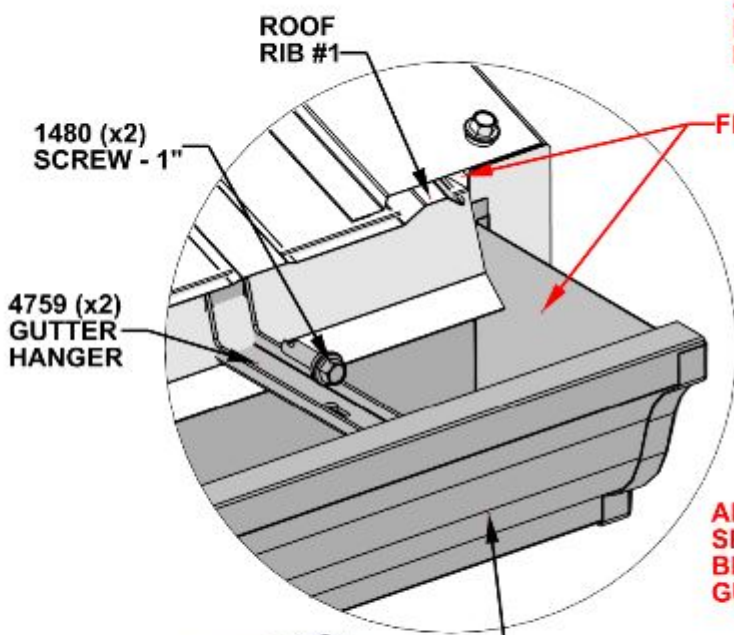

APPLY SILICONE TO SPLICE GROOVE BEFORE INSERTING INTO GUTTER

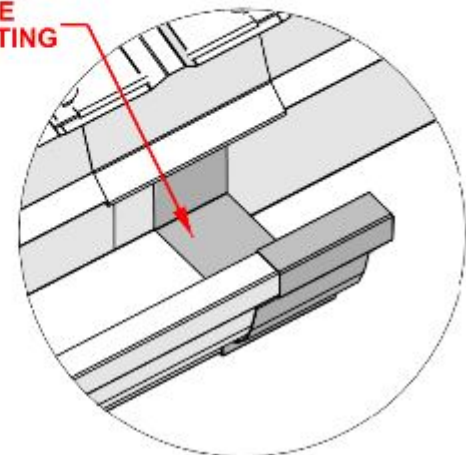

APPLY SILICONE TO SPLICE GROOVE BEFORE INSERTING GUTTER INTO SPLICE

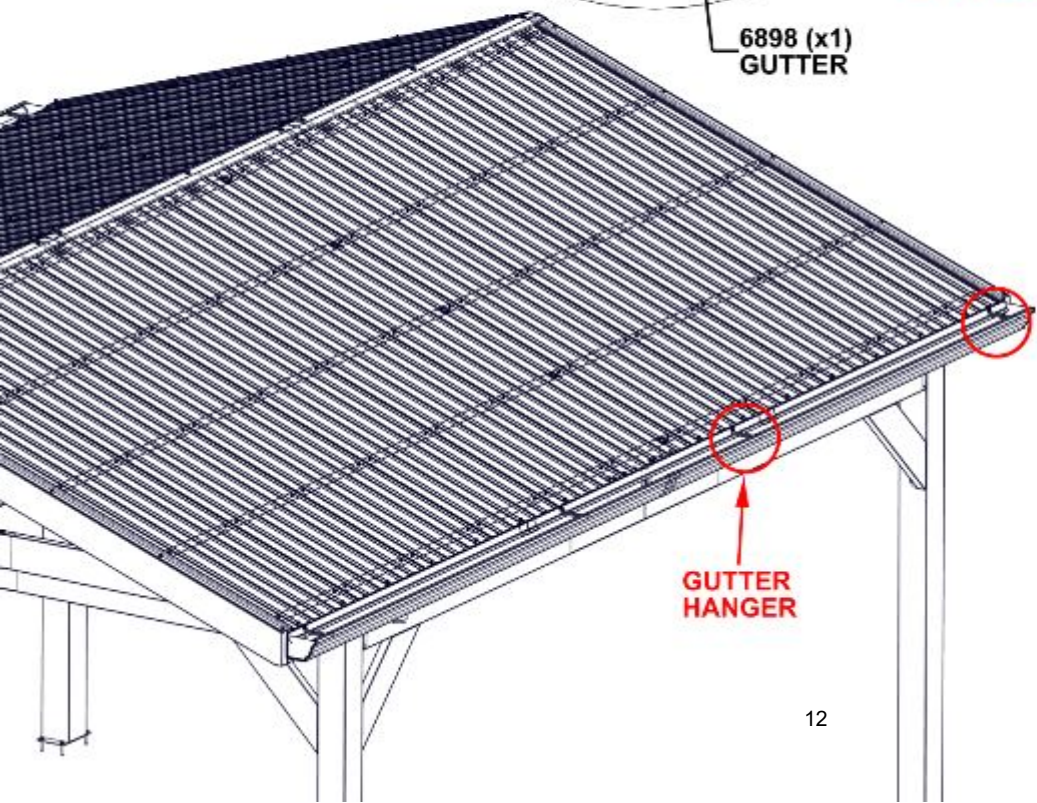
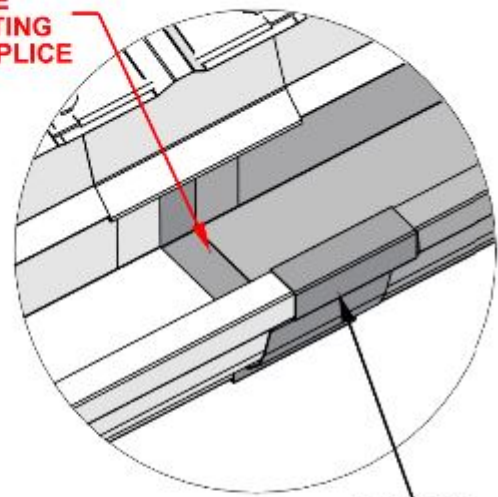

4765 (x1) GUTTER SPLICE

STEP 7 - GUTTER ASSEMBLY

QTY	PART NUMBER	DESCRIPTION
8	H101480	SCREW SELF TAPPING #9x1 BLK

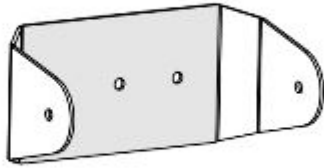

A4M04782 DOWNSPOUT CLIP
(x4)

- IT IS IMPORTANT TO CENTER 4782 DOWNSPOUT CLIPS ON POST.
- COMPLETE ON BOTH POSTS WITH DOWNSPOUT OUTLETS.

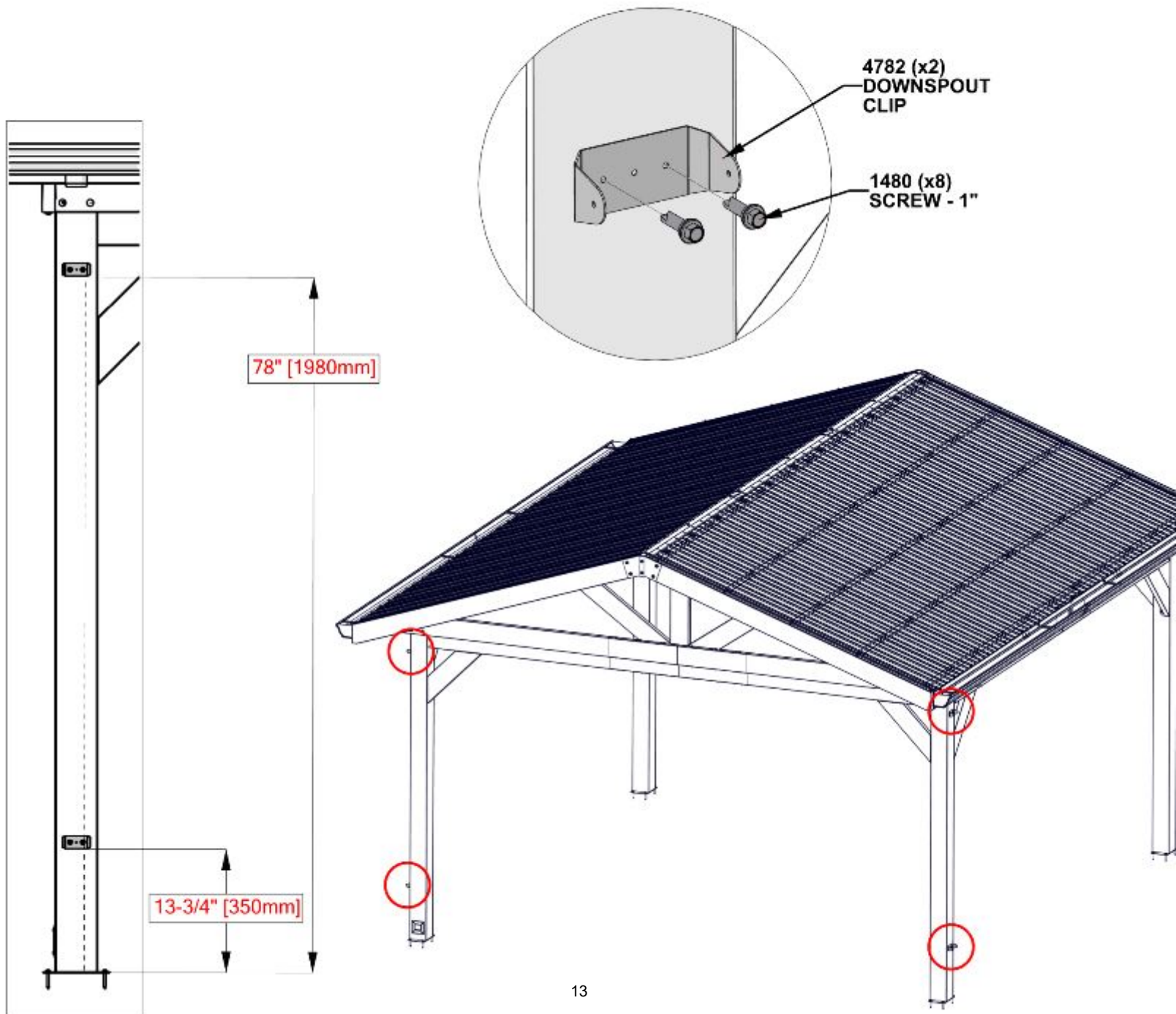

STEP 8 - GUTTER ASSEMBLY



A4M06238 LONG DOWNSPOUT ELBOW (x2)



A4M06685 DOWNSPOUT - 66" (x2)

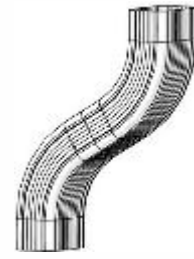

A4M06693 DOWNSPOUT OFFSET - 6" (x2)

- INSERT TAPERED ENDS INTO LARGER ENDS AS SHOWN.
- NOTE ORIENTATION OF DOWNSPOUT OFFSET. SEE DOWNSPOUT OFFSET PAGE FOR DETAIL.
- COMPLETE THIS STEP TWICE.

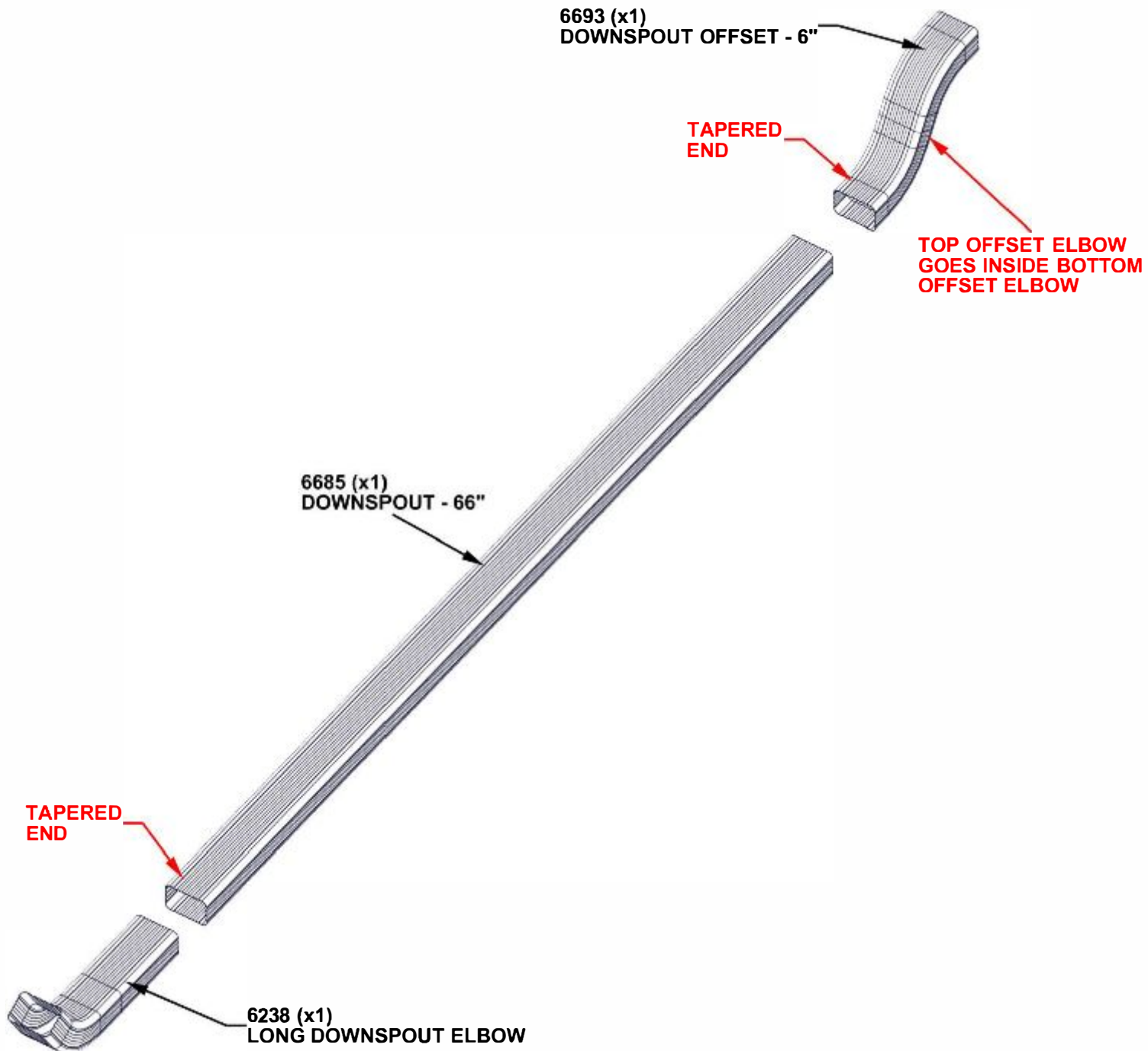

STEP 9 - GUTTER ASSEMBLY



DOWNSPOUT ASSEMBLY - STEP 8

QTY	PART NUMBER	DESCRIPTION
2	H101414	SCREW SELF PIERCING #8x1/2 BLK

- SLIDE DOWNSPOUT ASSEMBLY OVER GUTTER OUTLET AND ATTACH WITH HARDWARE PROVIDED.
- NOTE GUTTER WILL NOT EXTEND TO GROUND, THERE WILL BE FLOATING SPACE.
- COMPLETE THIS AT BOTH CORNERS WITH DOWNSPOUT OUTLET.

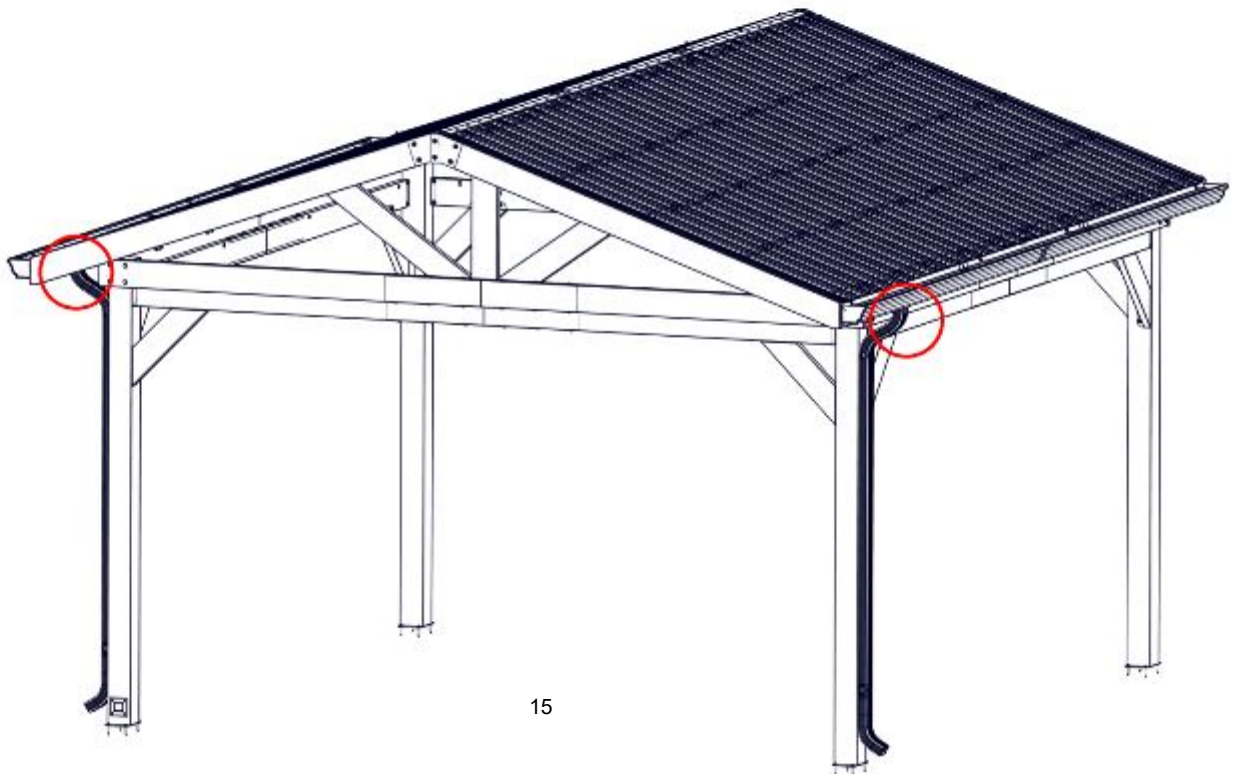
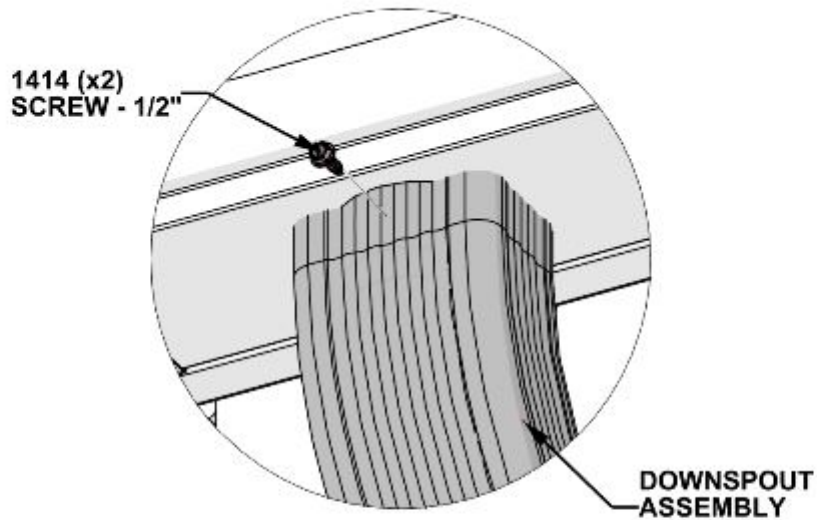

STEP 10 - GUTTER ASSEMBLY

QTY	PART NUMBER	DESCRIPTION
8	H101414	SCREW SELF PIERCING #8x1/2 BLK

- ATTACH DOWNSPOUT CLIPS TO DOWNSPOUTS.

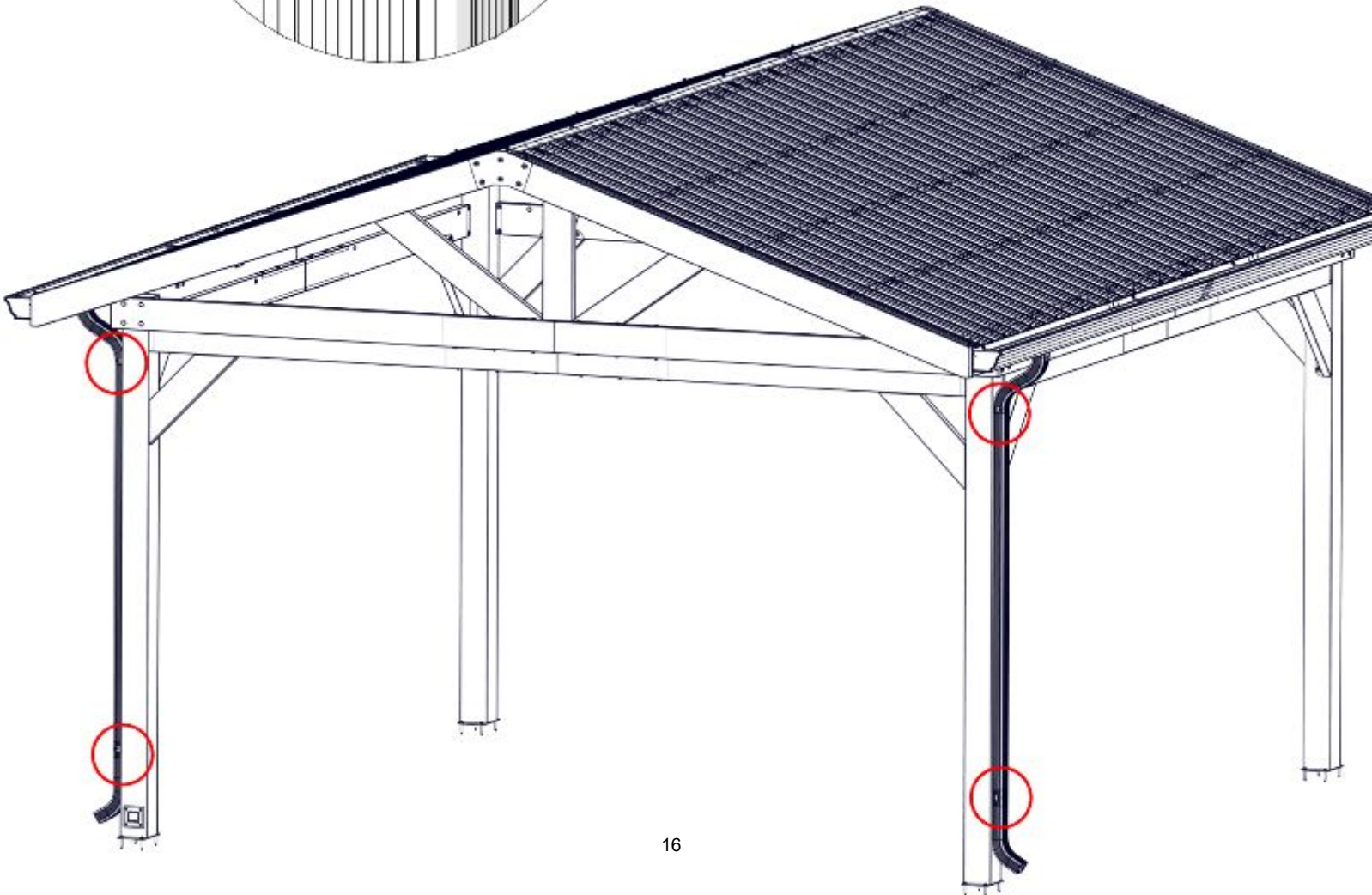
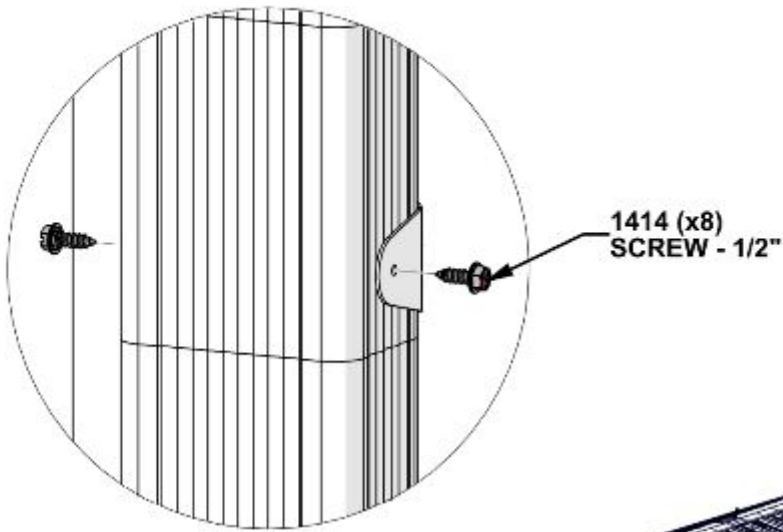

STEP 11 - GUTTER ASSEMBLY

QTY	PART NUMBER	DESCRIPTION
10	H101480	SCREW SELF TAPPING #9x1 BLK

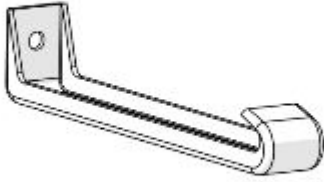

A4M04759 GUTTER HANGER
(x10)

- ATTACH REMAINING GUTTER HANGERS APPROXIMATELY 22" [560mm] APART.

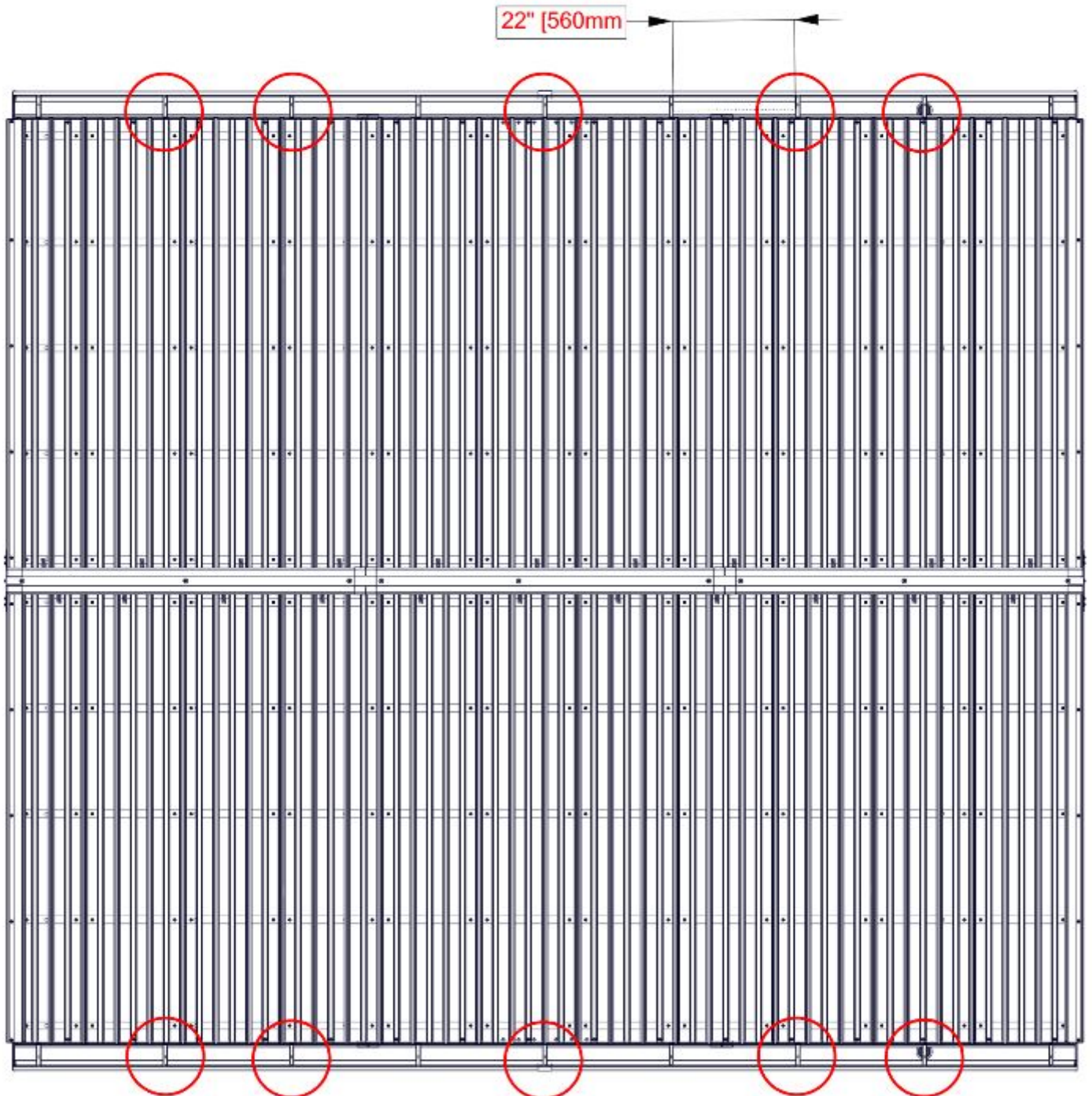

STEP 12 - GUTTER ASSEMBLY

CRITICAL:

AFTER HARDWARE AND GUTTERS ARE INSTALLED IT IS IMPORTANT THAT A HEALTHY BEAD OF SILICONE IS WORKED INTO THE OVERLAPPING JOINTS CIRCLED IN RED. THE RED LINES INDICATE THE SPLICE JOINTS THAT NEED TO BE CAULDED TO AVOID LEAKING. MAKE SURE SILICONE IS APPLIED TO THE CURVED SURFACES OF GUTTERING AS WELL.

TIP: A WET FINGER HELPS WORK SILICONE INTO SPACES.

