

WALKER EDISON
TM

**Sloane 58" 3 Drawer
Solid Wood TV Stand**

SKU# W58IV3D

LOT: AAYYWW-XXX

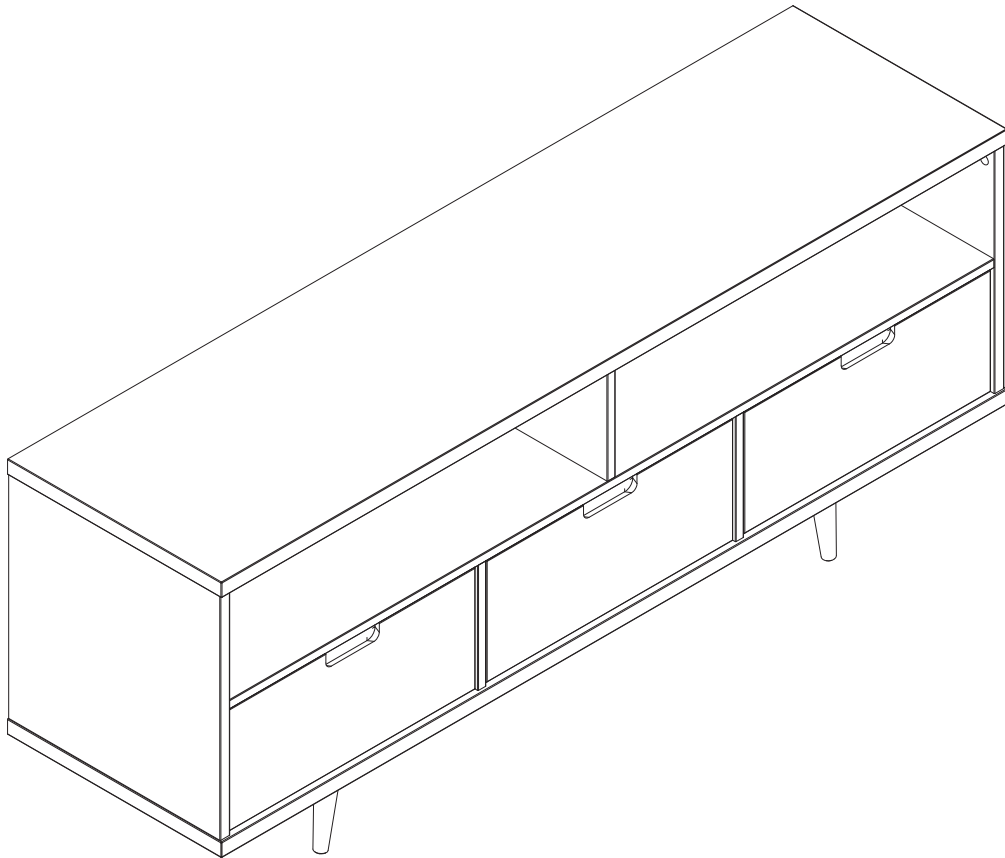

For Residential Use Only

Please visit our website for the most current instructions, assembly tips, report damage, or request parts. www.walkeredison.com

WE Time to get started

Set up a clean and soft workplace to avoid damage during assembly. You can use the box and internal protections as a cover. It also helps to double-check if you have got all the pieces and parts before diving into the assembly.

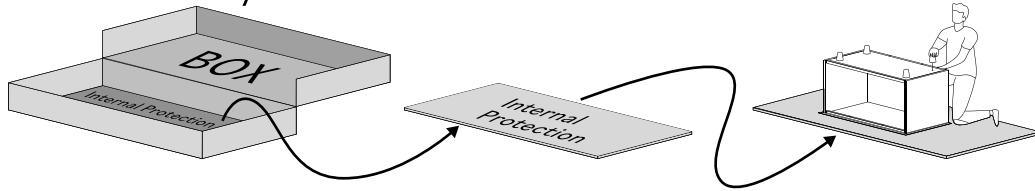

**Estimated time
for assembly**

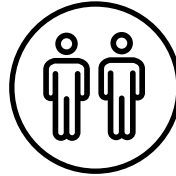

2 People Build

**People recommended
for assembly**

Make it a team effort!
Grab a friend for quicker,
easier assembly.

Tools Needed

Grab a Phillips head screwdriver and a hammer to conquer this assembly.

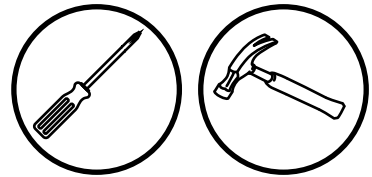

Use power tools with caution

This furniture is made of Solid Wood and Composite Wood, soft materials. If you choose to use power tools, set it to the slower setting. Be careful! Power tools can cause cracking or damage to the furniture, they can also damage the hardware if misused.

Power tool damages are not covered by the Walker Edison warranty.

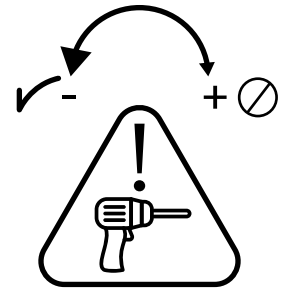

Scan to get assembly tips and help!

WE Parts List

Part Number	Description	Quantity
1	Top Panel	1
2	Shelf	1
3	Base	1
4	Center Upper Panel	1
5	Center Bottom Panel	2
6	Left Side Panel	1
7	Right Side Panel	1
8	Feet	2
9	Upper Back Panel	1
10	Back Panel	1
11	Drawer Front	3
12	Drawer Left Side	3
13	Drawer Right Side	3
14	Drawer Bottom	3
15	Drawer Back	3
17	Drawer Slide	6

WARNING Serious or fatal crushing injuries can occur from tip-over. To help prevent tip-over, install tip restraints per instructions.

If using to support a television or monitor:
 • For use with televisions weighing 55lbs (25kg) or less and no wider than this product. Use with heavier televisions may result in instability causing tip-over, resulting in death or serious injury.
 • Death or serious injury may occur when children climb on audio or video equipment furniture. Remote control or toys placed on the furnishing may encourage a child to climb on the furnishing and as a result the furnishing may tip over on the child.
 • Do not place TV near the front edge of the product.

To further reduce the risk of serious injury and death from tip-overs:
 • Place heaviest items in the lowest compartments or drawers.
 • Never allow children to climb or hang on drawers, doors or shelves.
 • Never open more than one drawer at a time.

The use of tip-over restraints may only reduce, but not eliminate the risk of tip-over.
 For safe mounting, it is essential to use wall anchors appropriate to your wall type (i.e., plaster, drywall, concrete, etc.).
 Mount to wood studs wherever possible. Note: if you are unsure about your wall type or what mounting method you should use, consult a qualified professional or your local hardware store.

TELEVISION MAXIMUM LOAD SHALL EXCEEDING 101.4 KG
PRODUCT WEIGHING 25.5KG MAXIMUM

WALKER EDISON
 Ivy
 Distribution and responsible for the anti-tip hardware:
 Walker Edison Furniture Company
 1553 W 9000 S, West Jordan, UT 84088 United States







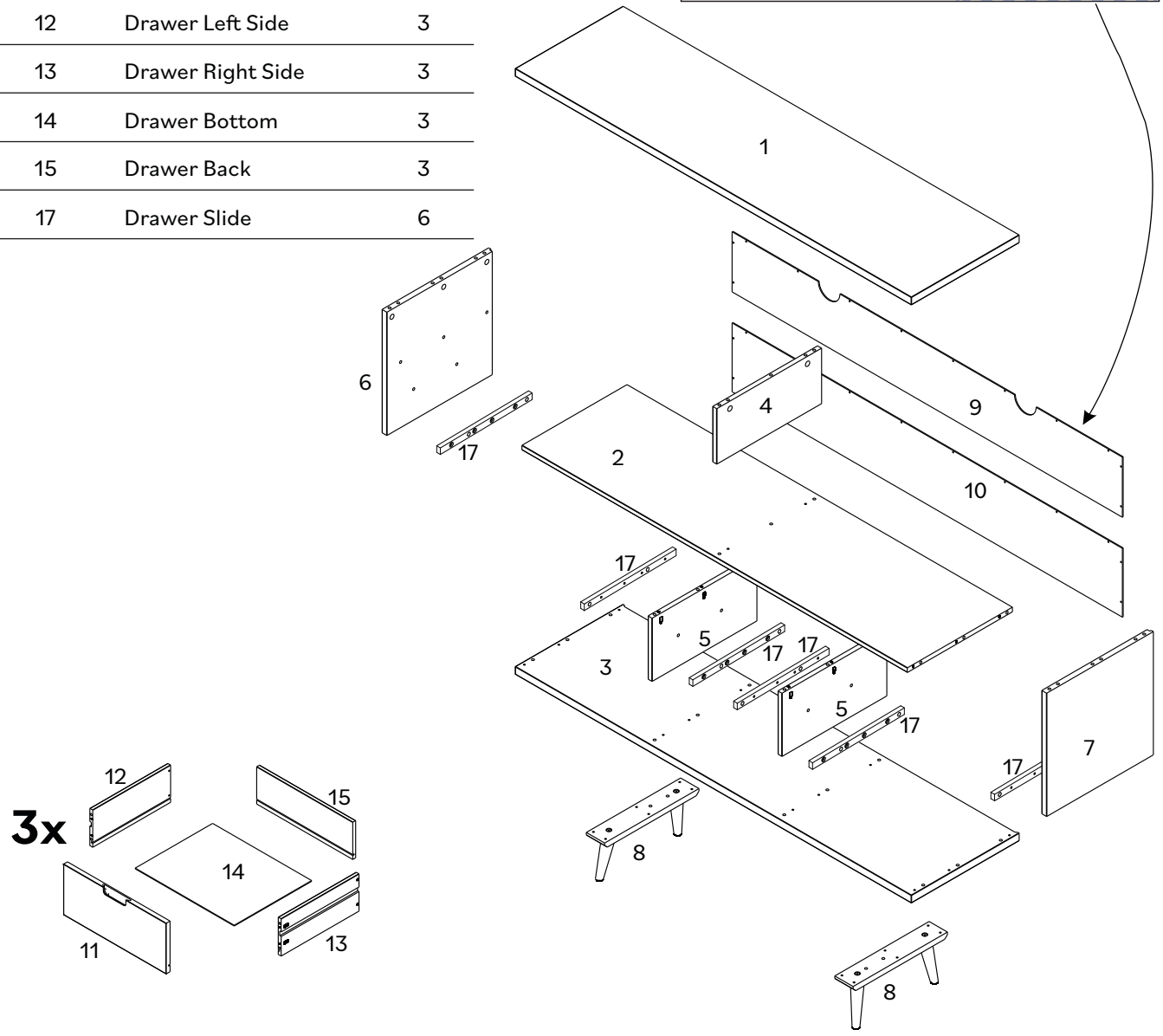

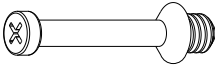

Model: **W581V3DCA**
 LOT: **ST2505-003**
 Date: **29/2025**
 Rev. **12/2024 V1**

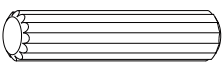
CANFER compliant / conforme au CANFER
 TSCA Title VI compliant / conforme au titre VI de la TSCA
 TSCA Title VI certified / certifié conformément au titre VI de la TSCA
 California 93120 Compliant for Formaldehyde / Conforme à la norme Californie 93120 pour le formaldéhyde.

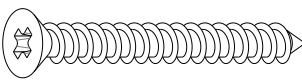
For details on Assembly Videos, Assembly Instructions, Replacement Parts and Customer Service. SCAN HERE.

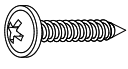
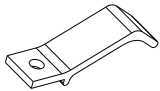

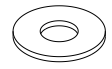
WE Hardware List

Part	Size	Name	Quantity
A 	5,5x28mm	Cam Bolt	8
B 	14x14mm	Cam Lock	8
C 	3,5x30mm	Screw	48
D 	8x30mm	Wooden dowel	51
F 	8x20mm	Wooden dowel	12
G 	4x40mm	Screw	14
H 		Metal Plate	8
I 	4x16mm	Screw	60
J 		Drawer Limiter	3
K 	3,5x30mm	Screw	1
L 		Washer	2
M 	Ø6mm	Plastic Bush	1
N 		Wall Anchor	1

Step 1

Let's start! Insert Wooden dowel (D) into Shelf (2), Center upper panel (4), Center bottom panel (5), Left side panel (6), Right side panel (7), Feet (8), Drawer left side (12) and Drawer right side (13).

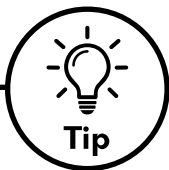
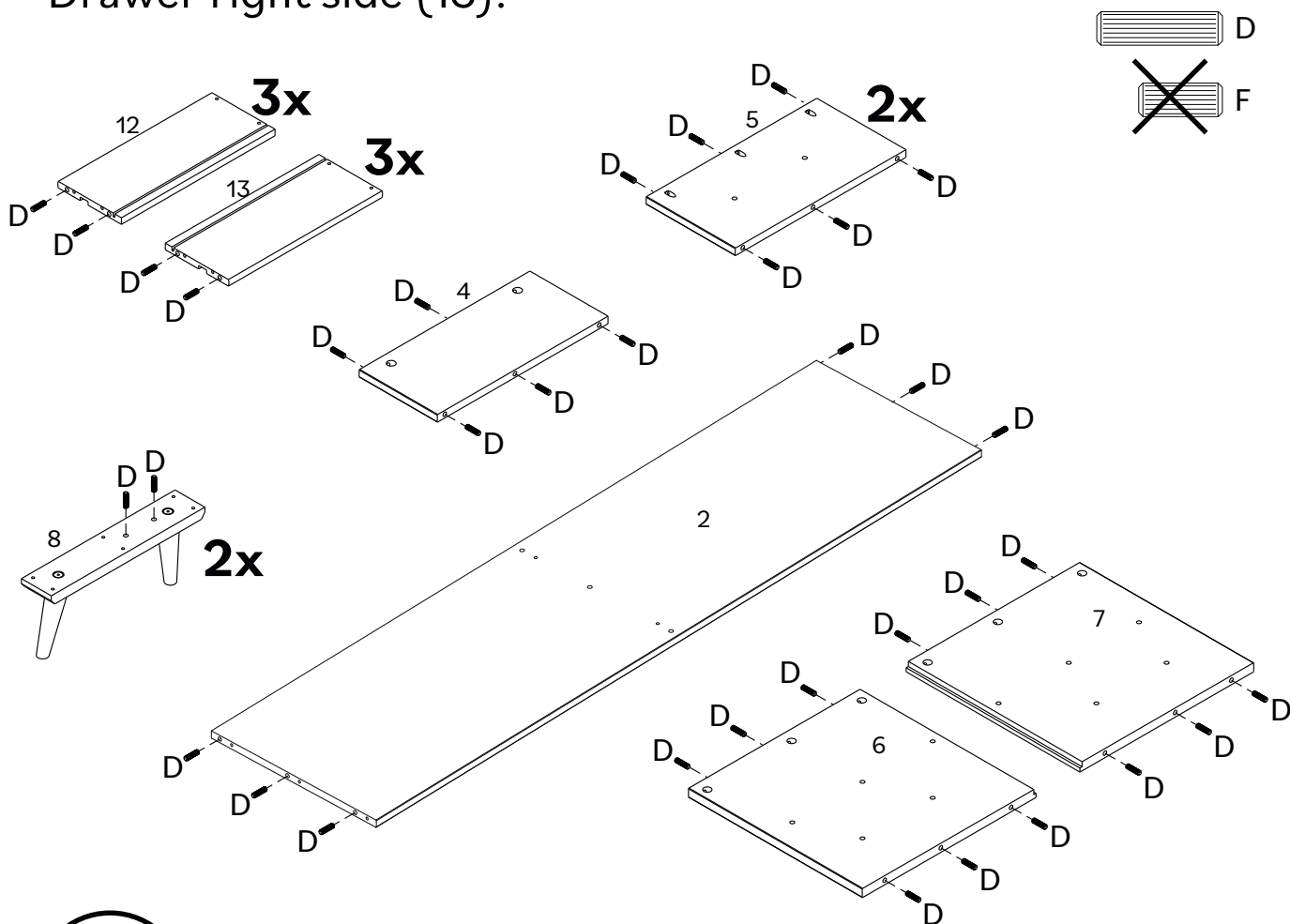

Tip

Wood Dowels

Dowels are essential in furniture assembly to create strong, precise connections. They ensure structural integrity, prevent shifting, and simplify alignment, resulting in sturdier, longer-lasting furniture.

Follow these steps:

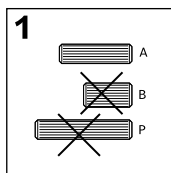

1: Select the appropriate size dowel according with step.

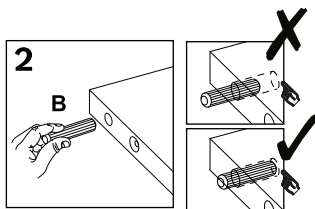

2: Insert into drilled hole and press firmly to ensure placement is set.

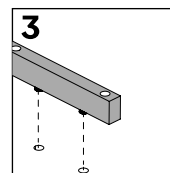

3: Align the dowel with corresponding piece and press together until secure.

Step 2

Insert Wooden dowel (F) into Drawer slide (17). Attach the Drawer Slide (17) to Left side panel (6) and Right side panel (7) using Screw (I) and a Phillips head screwdriver.

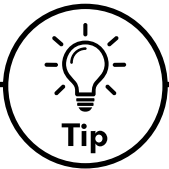
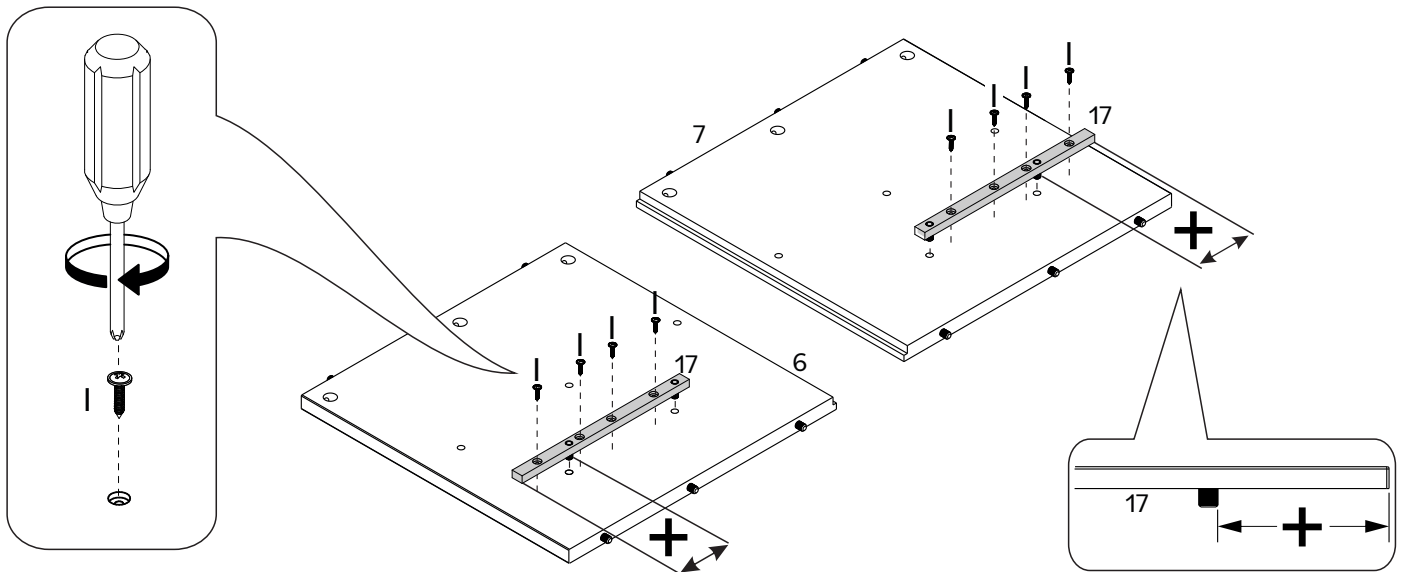
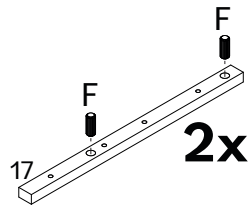
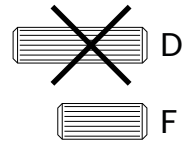

To keep your product looking its best and scratch-free, try assembling it on a soft surface like carpet or a blanket. This helps prevent any accidental scratches and keeps your furniture in top shape!

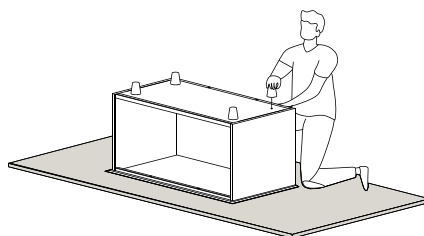

Step 3

Insert Wooden dowel (F) into Drawer slide (17). Then attach the Drawer Slide (17) to Center bottom panel (5) using Screw (I) and a Phillips head screwdriver. Do this on both sides.

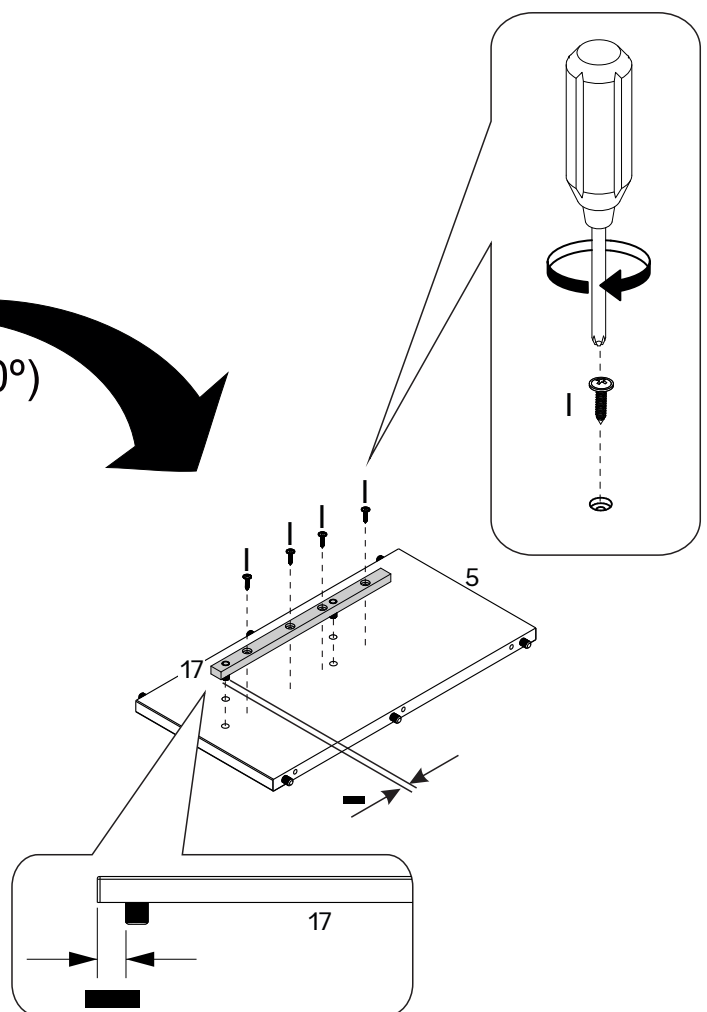
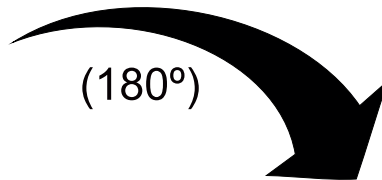
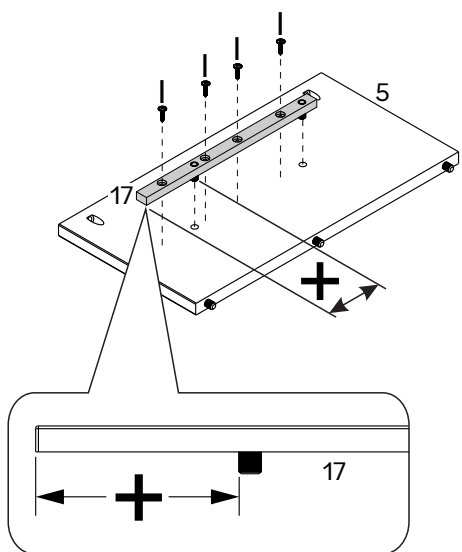
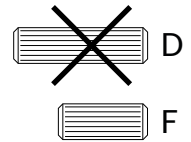
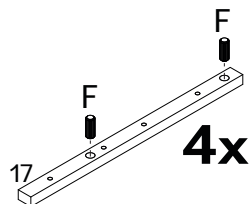
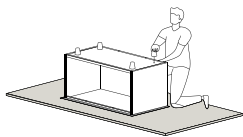

Step 4

Join Center upper panel (4) and Shelf (2) using Screw (G) and a Phillips head screwdriver

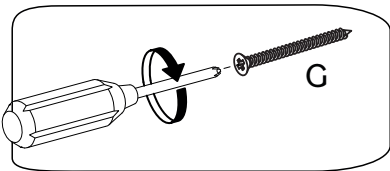
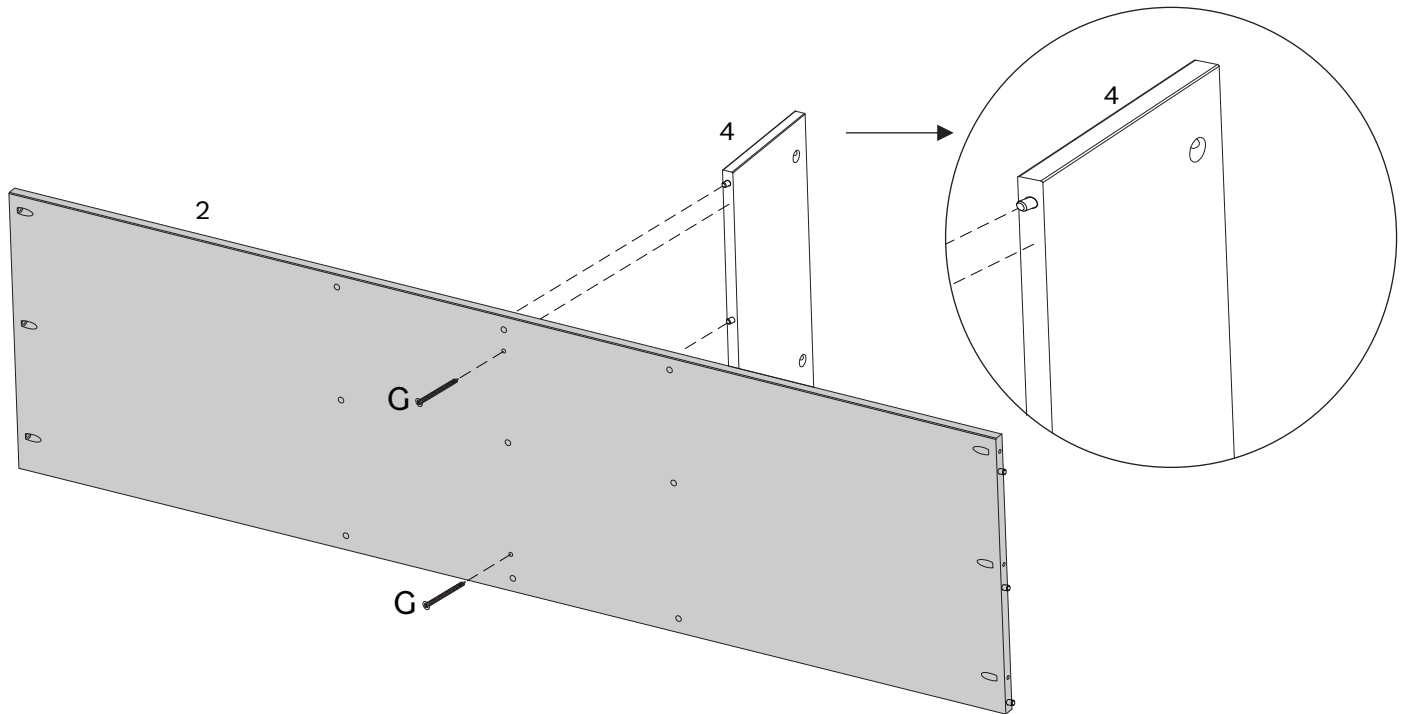
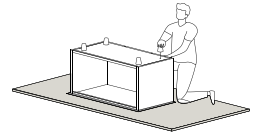

Step 5

Attach Center bottom panel (5) to Shelf (2) using Screw (C) and a Phillips head screwdriver

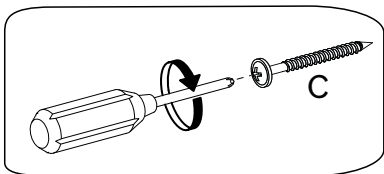
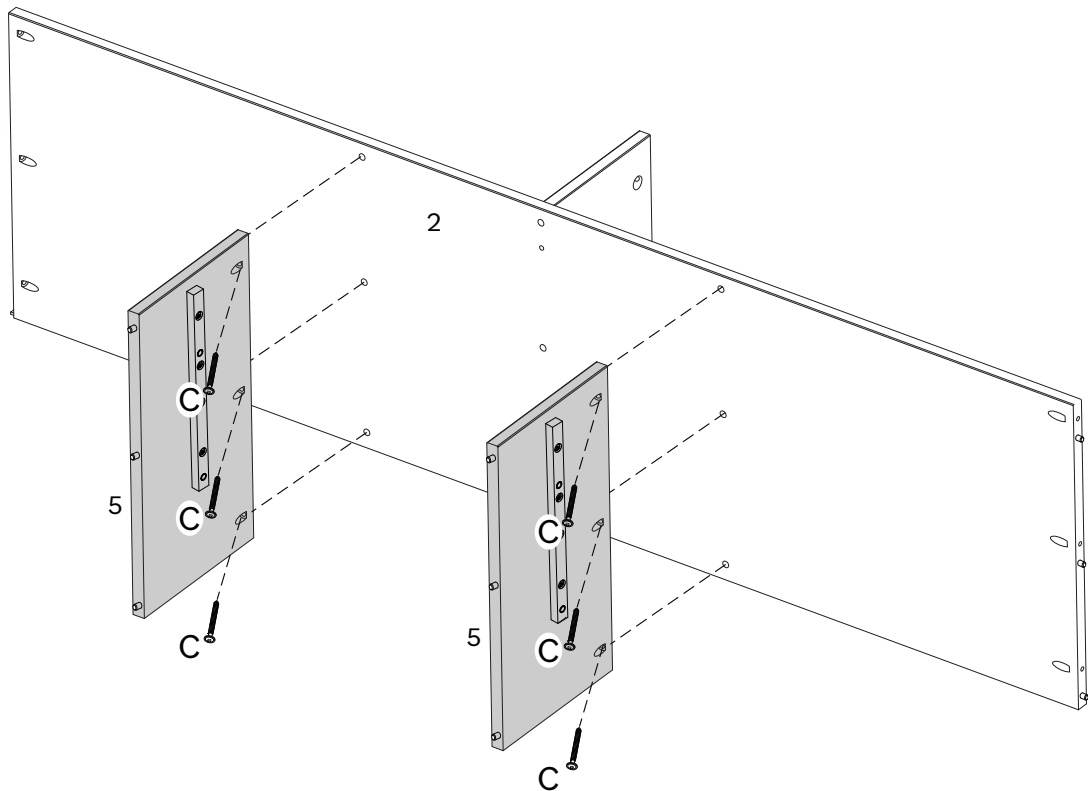
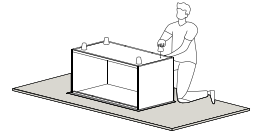

Step 6

Secure Left side panel (6) and Right side panel (7) to Shelf (2) using Screw (C) and a Phillips head screwdriver

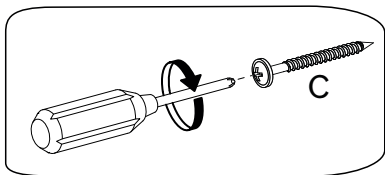
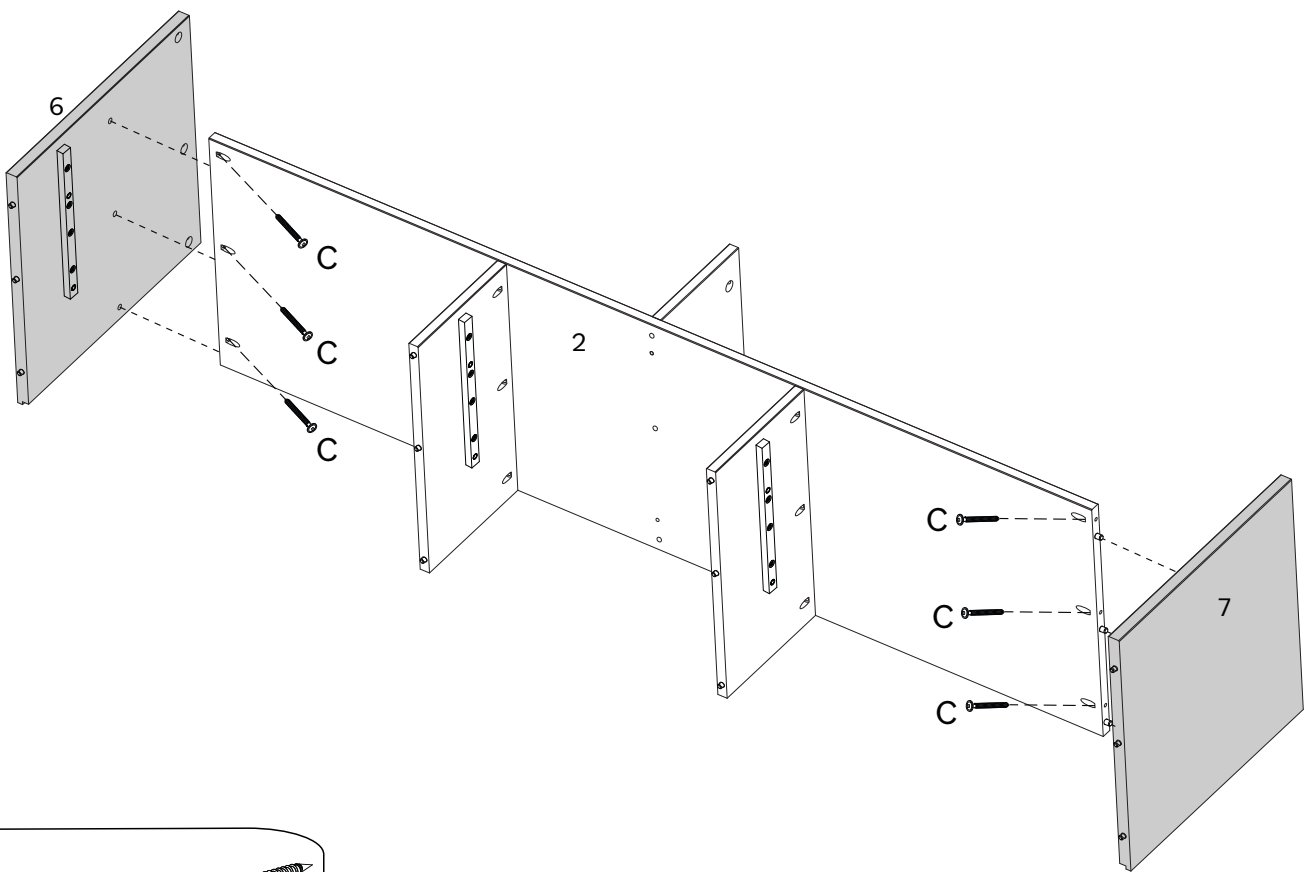
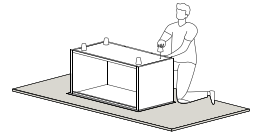

Step 7

Attach Cam Bolt (A) into the holes in Top panel (1).

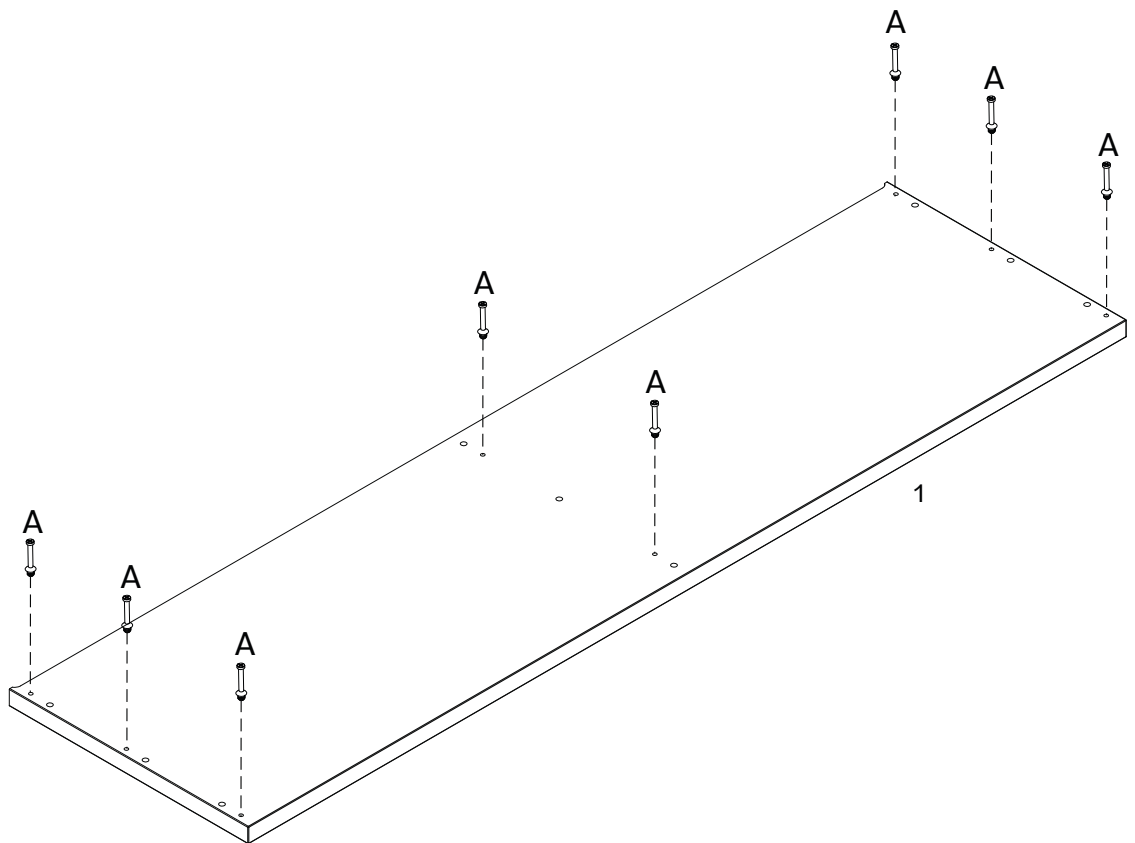
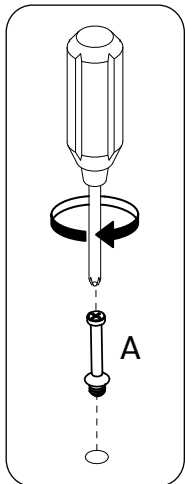
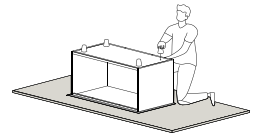

Step 8

Attach Feet (8) to Base (3) using Screw (C) and a Phillips head screwdriver. Also use screw (I) to fix Drawer limiter (J) into Base (3).

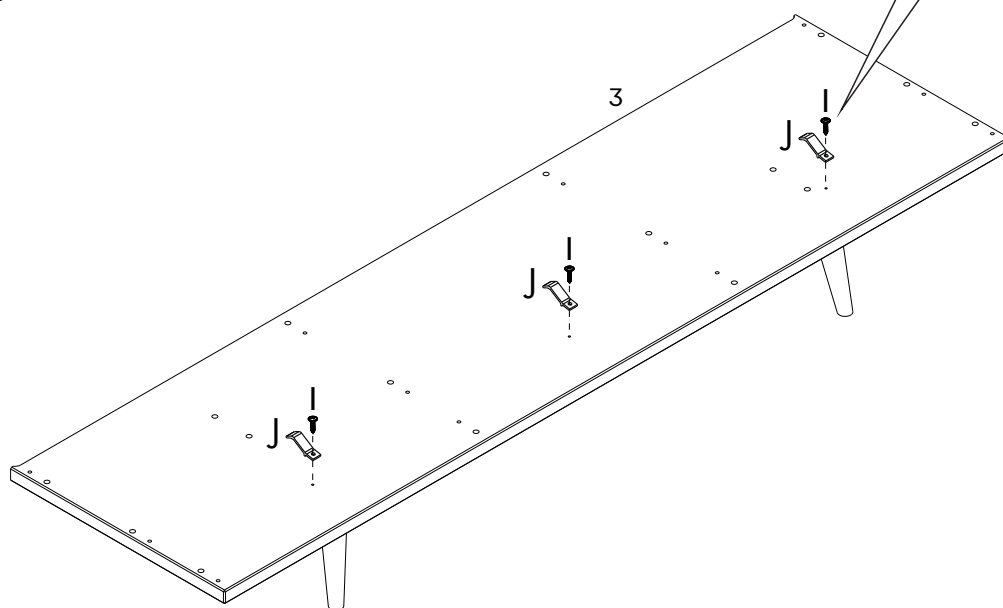
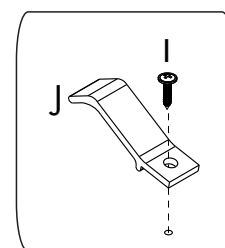
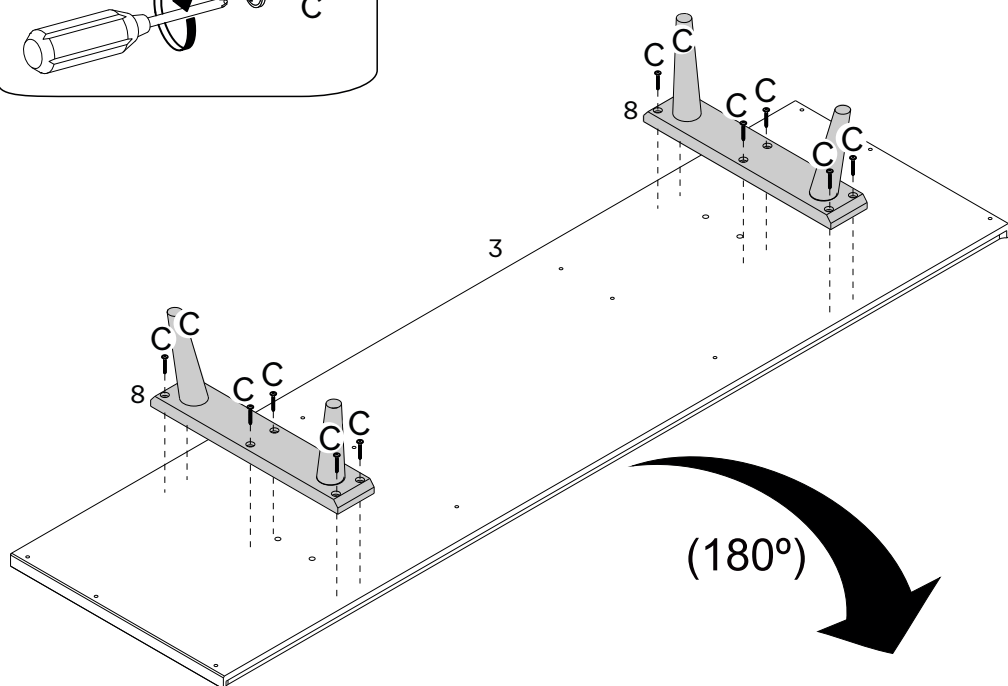
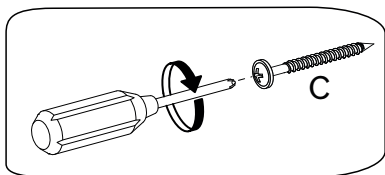
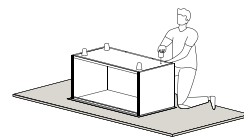

Step 9

Assemble Top panel (1) and Base (3) into Left side panel (6) and Right side panel (7) using Screw (G) and tightening Cam bolt (B) with a phillips head screwdriver.

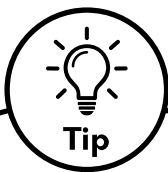
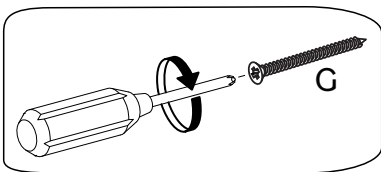
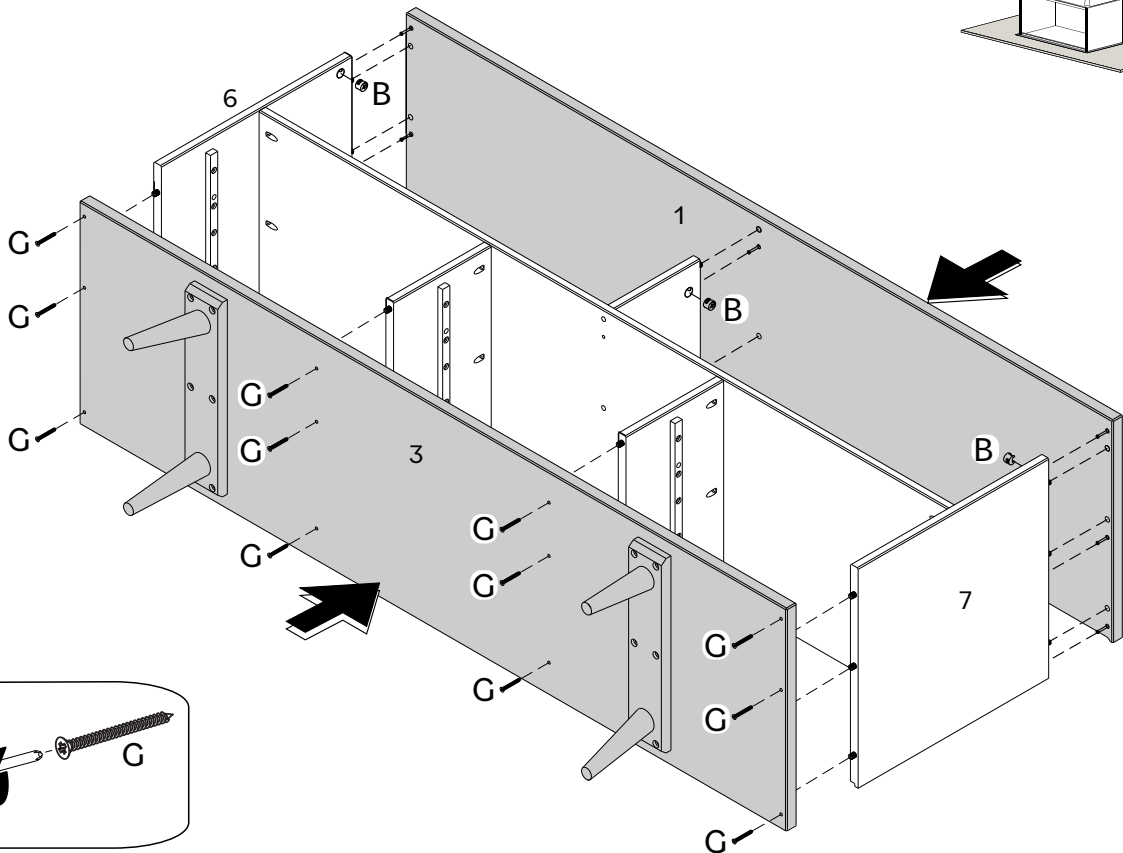
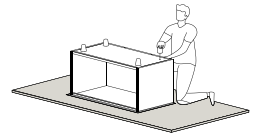

Tip

Cam Locks

Cam Locks help securely join two pieces together.
Follow these easy steps.

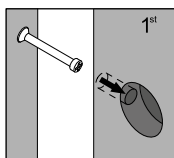

1: Insert Cam Bolt into bolt holes on the flat side. Don't over tighten!

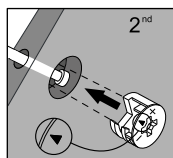

2: Assemble both parts together. The cam bolts goes in the drills holes that have a circular hole on the side, you should be able to see the cam bolt through it. After fitting parts together insert the cam lock on the side holes.

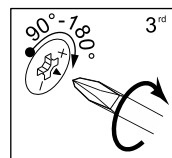

3: On the back of the Cam Lock will be a "C" shape. Insert the Cam Lock so the opening of the "C" fits over the Cam Bolt. Tighten with the screwdriver.

Step 10

Use Metal Plate (H) and Screw (I) to assemble the Back panels (9,10) with a Phillips head screwdriver.

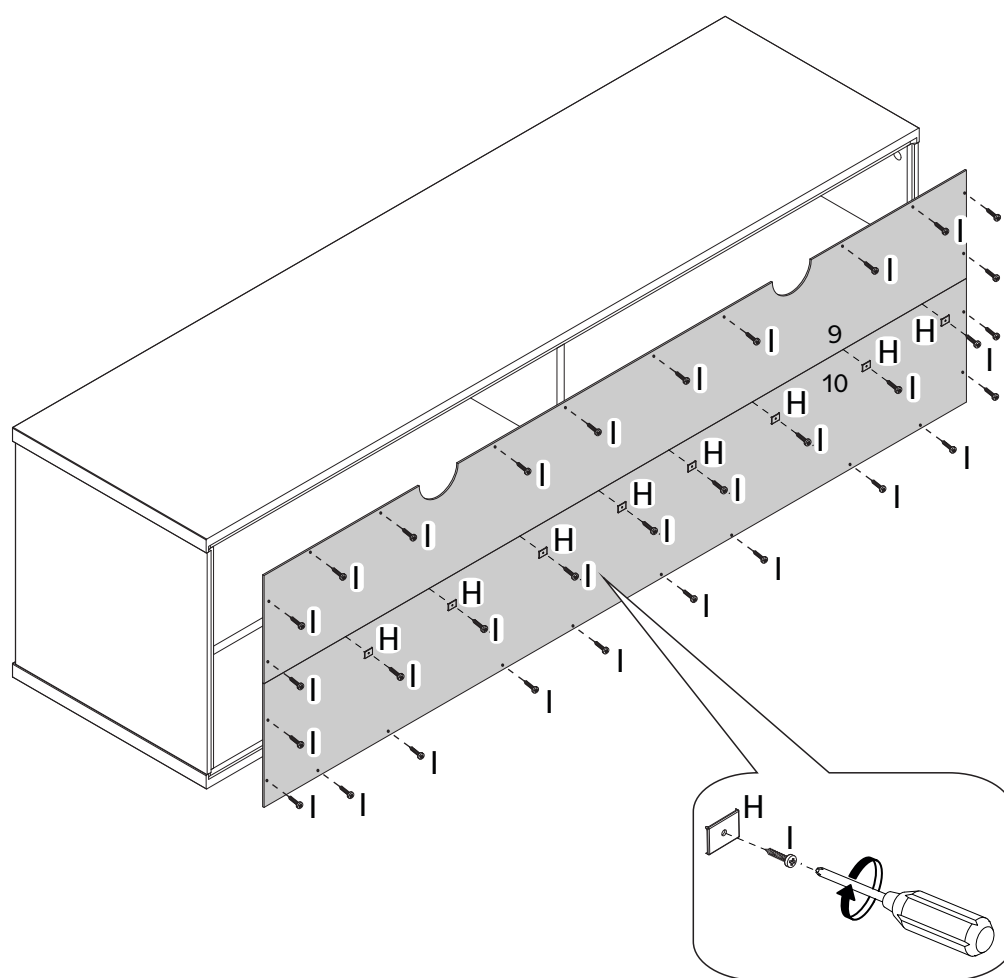

Step 11

Now we will assemble the drawers. Attach Drawer left side (12) and Drawer right side (13) to Drawer front (11) using Screw (C) and a phillips head screwdriver.

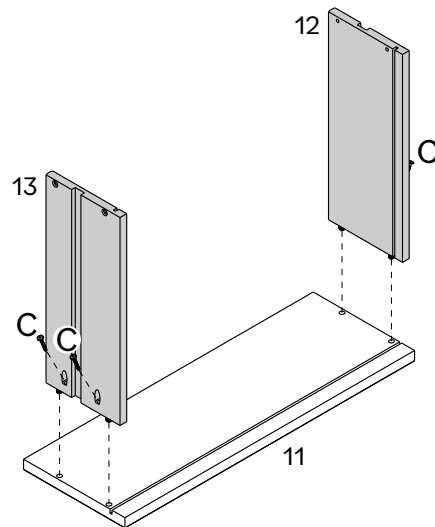
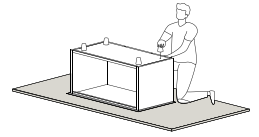

Step 12

Slide Drawer bottom (14) on grooves on Drawer sides (12,13) fitting in Drawer front (11). Then, Secure Drawer back (15) to Drawer Left side (12) and Drawer right side (13) using Screw (C) and a Phillips head screwdriver.

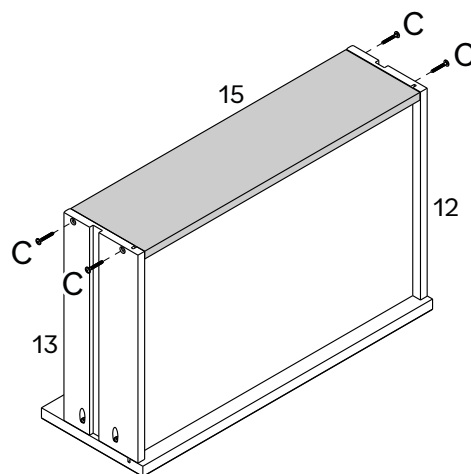
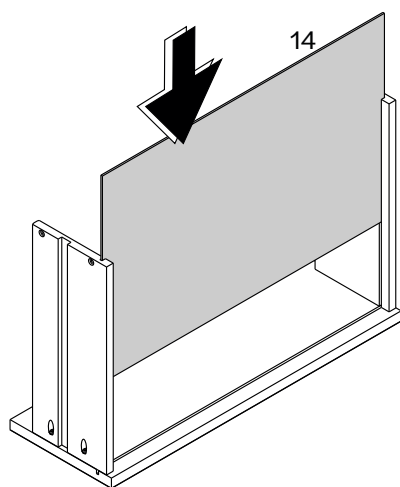
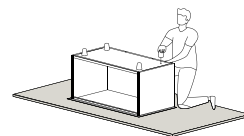

Step 13

To finish this up, let's secure your TV Stand to the wall!
Attach the Wall anchor (N) to your TV Stand using Washer (L), Screw (I) and a Phillips head screwdriver.

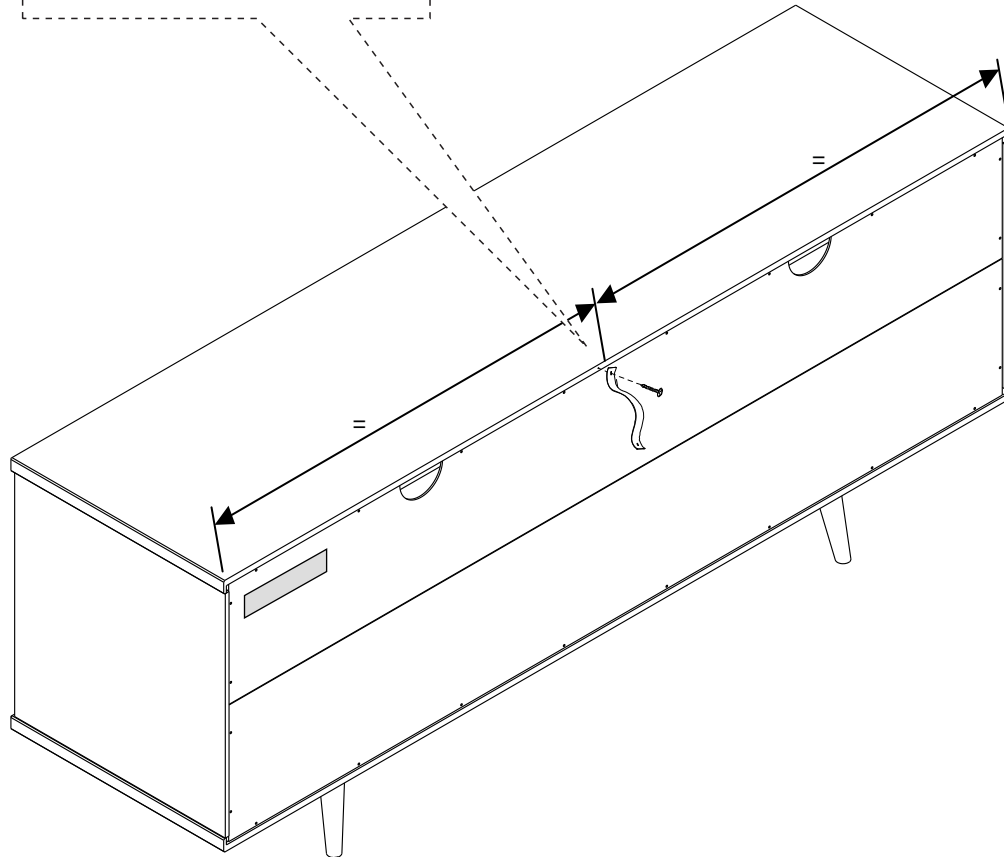
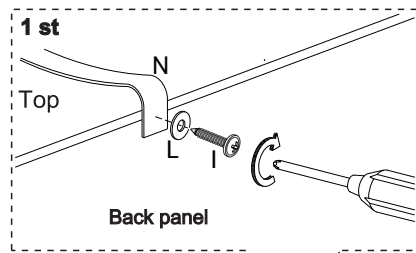

Step 14

Insert the Plastic Bush (M) into the wall. Then, secure the Wall anchor (N) to the wall using a Washer (L), Screw (K) and a Phillips head screwdriver.

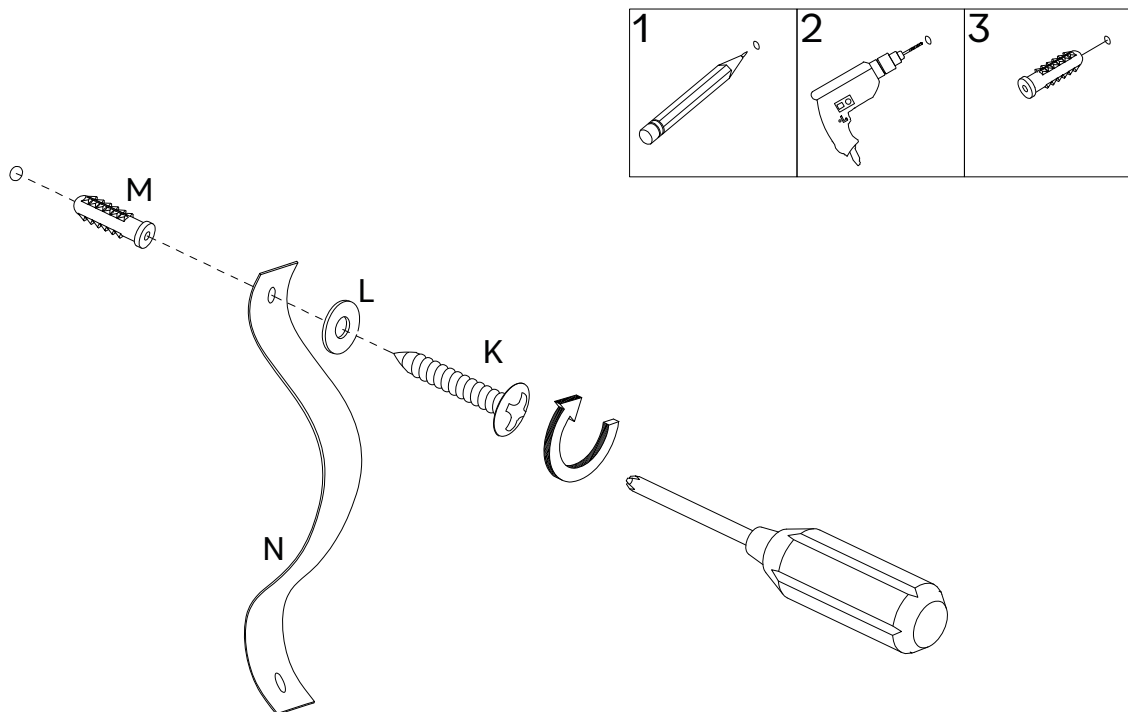

WARNING

Serious or fatal crushing injuries can occur from tip-over. To help prevent tip-over, install tip restraints per instructions. If using to support a television or monitor:

- Death or serious injury may occur when children climb on audio/or video equipment furniture. Remote control or toys placed on the furnishing may encourage a child to climb on the furnishing and as a result the furnishing.
- Do not place TV near front the edge of the product.

To further reduce the risk of serious injury and death from tip-overs:

- Place heaviest items in the lowest compartments or drawers.
- Never allow children to climb or hang on drawers, doors or shelves.
- Never open more than one drawer at a time.

The use of tip-over restraints may only reduce, but not eliminate the risk of tip-over.

For safe mounting, it is essential to use wall anchors appropriate to your wall type (i.e., plaster, drywall, concrete, etc). Mount to wood studs whenever possible. Note: if you are unsure about your wall type or what mounting the method you should use, consult a qualified professional or your local hardware store.

Name and address information for the manufacturer responsible for the anti-tip hardware and date of production can be found on the label on the back of the furniture.

You did it! Enjoy your new TV Stand!

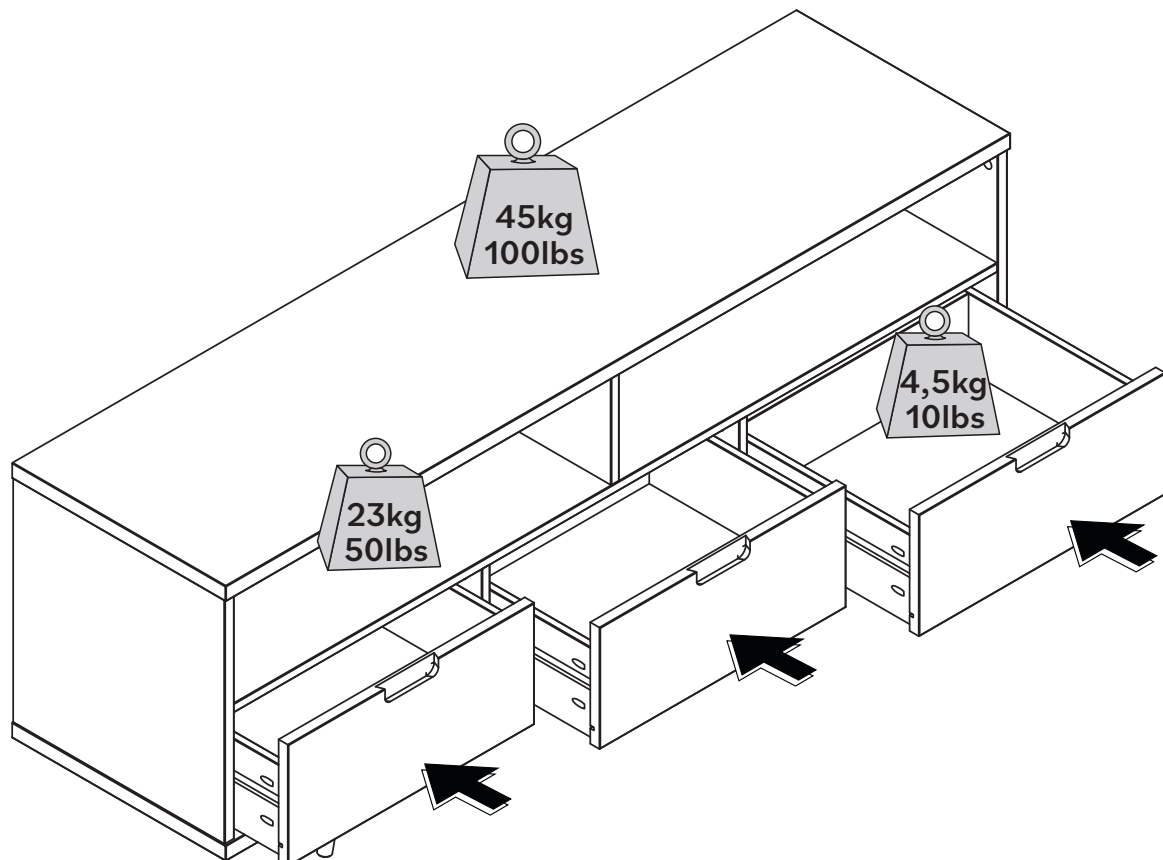

Congratulations on your new piece of furniture!

We would love to hear about it and see it.
Please leave us a review or post a picture with
#mywalkerredisonhome

Assembling furniture can be tricky sometimes.

Our customer service team, located in Utah, is here for product information, help assembling a product, or for any other customer support issue

Call us at **801-433-3008**

Email us at service@walkeredison.com

Visit our Customer Service website at walkeredison.com/pages/customer-service

We are available to help Monday -Thursday 8am-5pm, Friday 8am-3pm MST

For details on Assembly Videos, Assembly Instructions, Replacement Parts, and Customer service,

SCAN HERE

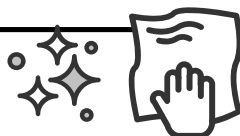

For cleaning, never use abrasives, use a soft cloth and water with neutral soap to clean the furniture.

WALKER EDISON™

Sloane 58" 3 Tiroirs en
bois massif TV Stand

Sloane 58" 3 Cajones de
madera maciza TV Stand

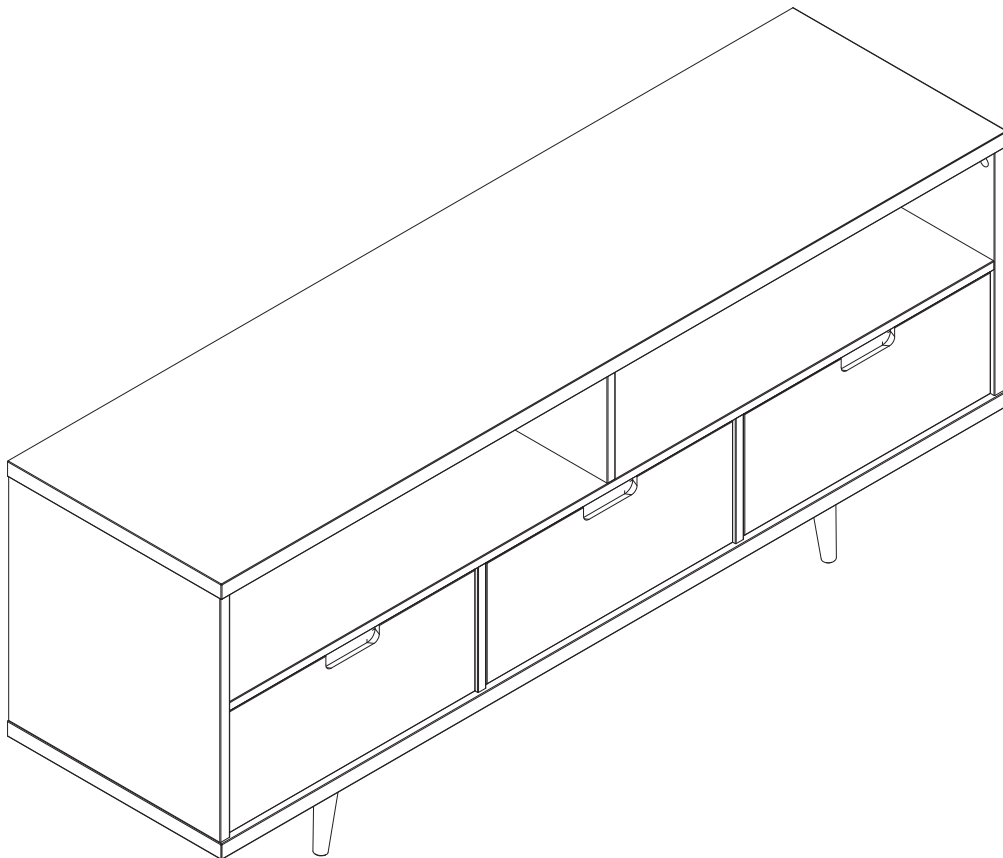

Pour usage résidentiel seulement

Visite notre site Web pour obtenir les instructions les plus récentes, des conseils d'assemblage, signaler des dommages ou commander des pièces. www.walkerredison.com

Sólo para uso residencial

Visite nuestro sitio web para consultar las últimas instrucciones, consejos de montaje, notificar daños o solicitar piezas. www.walkerredison.com

WE Il est temps de commencer / Hora de empezar

Prépare un lieu de travail propre et souple pour éviter tout dommage lors de l'assemblage. Tu peux utiliser la boîte et les protections internes comme base. Vérifie également que tu disposes de toutes les pièces et parties avant de te lancer dans l'assemblage.

Prepárese un lugar de trabajo limpio y blando para evitar daños durante el montaje. Puede utilizar la caja y las protecciones internas como base. Compruebe también que tiene todas las piezas y partes antes de sumergirse en el montaje.

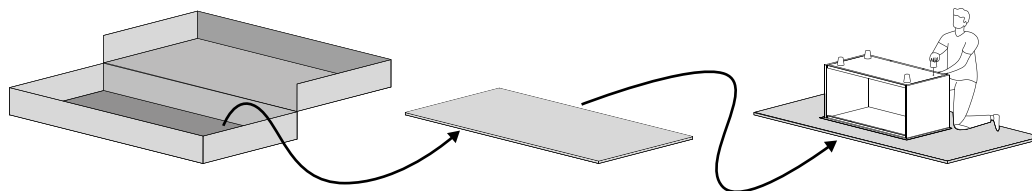

**Temps de montage
estimé**



**Tiempo estimado
de montaje**

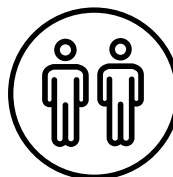

2 Personnes
2 Personas

**Personnes recommandées
pour le montage**

Fais-en un effort d'équipe !
Appelle un ami pour un assemblage
plus rapide et plus facile.

**Personas recomendadas
para el montaje**

¡Hágalo en equipo!
Llame a un amigo para que el montaje
sea más rápido y sencillo.

Outils nécessaires

Munis-toi d'un tournevis cruciforme et marteau pour réaliser cet assemblage.

Herramientas requeridas

Tome un destornillador Phillips y martillo para conquistar este montaje.

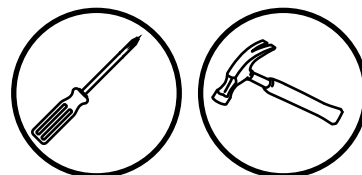

Utilise les outils électriques avec précaution

Ce meuble est réalisé en Bois Massif et Bois Composite, des matériaux souples. Si tu choisis d'utiliser des outils électriques, règle-les sur le mode le plus lent. Fais attention à toi ! Les outils électriques peuvent provoquer des fissures ou endommager les meubles, mais aussi les autres composants s'ils sont mal utilisés. Les dommages causés par un outil électrique ne sont pas couverts par la garantie Walker Edison.

Utilice las herramientas eléctricas con cuidado.

Este mueble está fabricado con madera maciza y madera compuesta, materiales blandos. Si decide utilizar herramientas eléctricas, ajústelas al ajuste más lento. Tenga cuidado. Las herramientas eléctricas pueden causar grietas o daños en el mueble, pero también en los herrajes si se utilizan mal. Los daños causados por una herramienta eléctrica no están cubiertos por la garantía de Walker Edison.

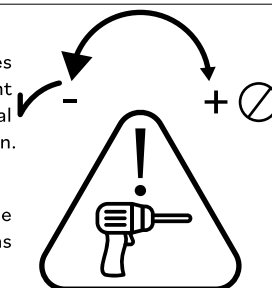

**Scannez pour obtenir des conseils d'assemblage et de l'aide !
¡Escanee para obtener consejos de montaje y ayuda!**

WE Liste de pièces / Lista de piezas

Nombre de pièces Número de pieza	Description Descripción	Quantité Cantidad
1	Panneau Supérieur Panel Superior	1
2	Étagère Prateleira	1
3	Panneau Inférieur Panel Inferior	1
4	Panneau Centrale Supérieur Panel Central Superior	1
5	Panneau Centrale Inférieur Panel Central Inferior	2
6	Panneau Gauche Panel Izquierdo	1
7	Panneau Droit Panel Derecho	1
8	Pied Pie	2
9	Panneau Supérieur Arrière Panel Superior Trasero	1
10	Panneau Arrière Panel Trasero	1
11	Façade du Tiroir Frente del Cajón	3
12	Côté Gauche du Tiroir Lado Izquierdo del Cajón	3
13	Côté Droit du Tiroir Lado Derecho del Cajón	3
14	Fond du Tiroir Inferior del Cajón	3
15	Arrière du Tiroir Trasero del Cajón	3
17	Glissière Corredera	6

WARNING Serious or fatal crushing injuries can occur from tip-over. To help prevent tip-over, install tip restraints per instructions.

If using to support a television or monitor

- For use with televisions weighing 35lbs (15.8kg) or less and no wider than this product. Use with heavier televisions may result in instability causing tip-over, resulting in death or serious injury.
- Death or serious injury may occur when children climb on audio/video equipment furniture. Remote control or toys placed on the furnishing may encourage a child to climb on the furnishing and as a result the furnishing may tip over on the child.
- Do not place TV near the front edge of the product.

To further reduce the risk of serious injury and death from tip-overs:

- Place heaviest items in the lowest compartments or drawers.
- Never allow children to climb or hang on drawers, doors or shelves.
- Never open more than one drawer at a time.

The use of tip-over restraints may only reduce, but not eliminate the risk of tip-over.

For safe mounting, it is essential to use wall anchors appropriate to your wall type (i.e., plaster, drywall, concrete, etc.). Mount to wood studs whenever possible. Note: if you are unsure about your wall type or what mounting method you should use, consult a qualified professional or your local hardware store.

TELEVISION MOUNTING LOADS SHOULD FOLLOW TO UL 1675

PRODUCT WEIGHING 35LBS MAXIMUM









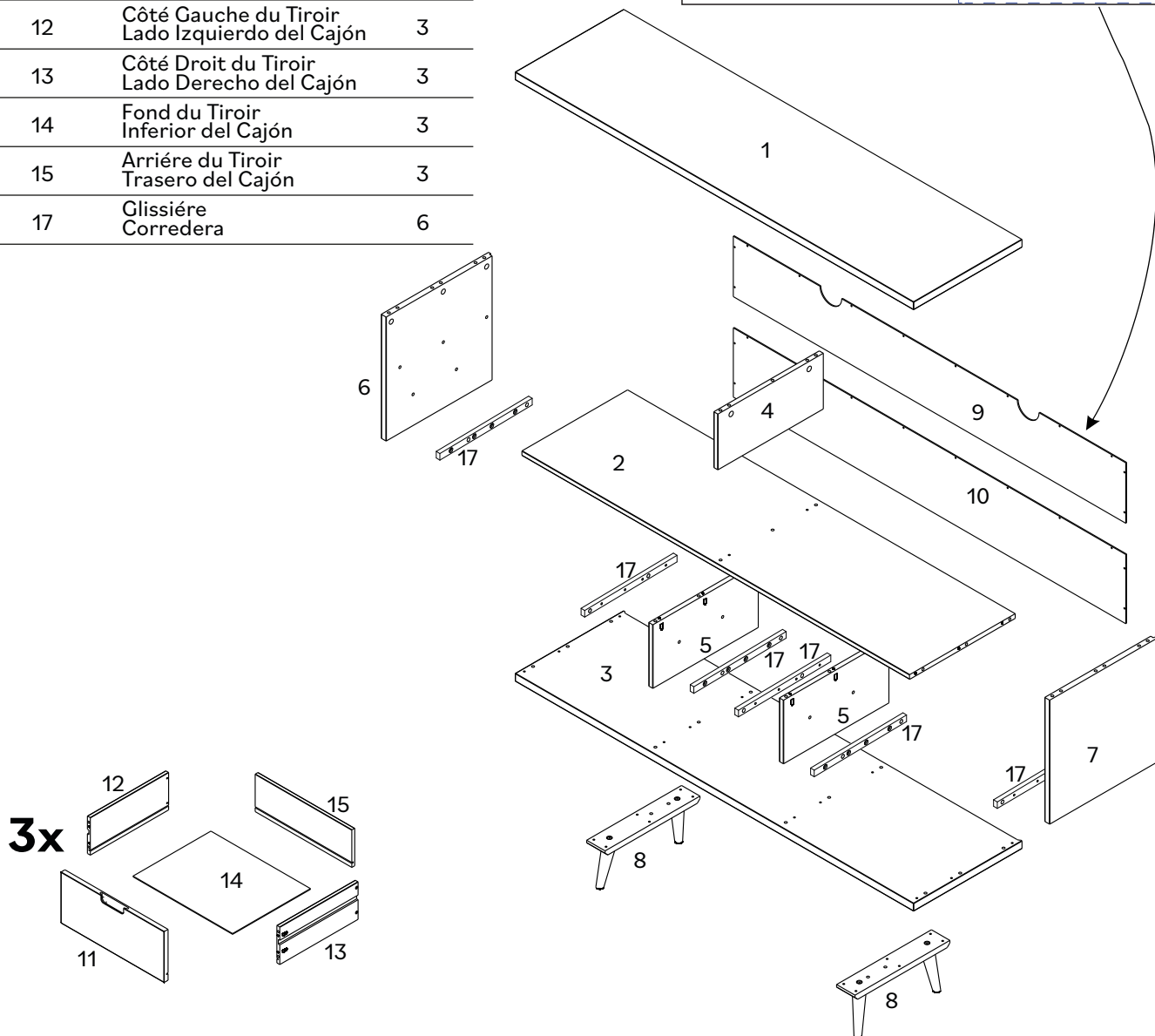

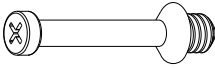
WALKER EDISON
Distribution and responsible for the anti-tip hardware:
Walker Edison Furniture Company
1553 W 9000 S, West Jordan, UT 84088 United States

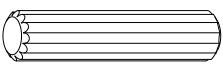
Model: **W581V3DCA**
LOT: **ST2505-003**
Date: **29/2025**
Rev. **12/2024 V1**

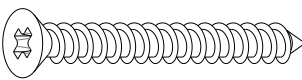
CANFER compliant / conforme au CANFER
TSCA Title VI compliant / conforme au titre VI de la TSCA
TSCA Title VI certified / certifié conformément au titre VI de la TSCA
California 93120 Compliant for Formaldehyde / Conforme à la norme California 93120 pour le formaldéhyde.

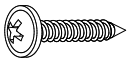
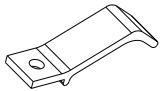
For details on Assembly Videos, Assembly Instructions, Replacement Parts and Customer Service. SCAN HERE.

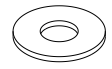

Partie Parte	Taille Tamaño	Nom Nombre	Quantité Cantidad
A 	5,5x28mm	Goujoun de Assemblage Conector	8
B 	14x14mm	Boitier de Assemblage Traba del Conector	8
C 	3,5x30mm	Vis Tornillo	48
D 	8x30mm	Cheville Espiga	51
F 	8x20mm	Cheville Espiga	12
G 	4x40mm	Vis Tornillo	14
H 		Plaque Placa	8
I 	4x16mm	Vis Tornillo	60
J 		Limiteur de Tiroir Limitador del cajón	3
K 	3,5x30mm	Vis Tornillo	1
L 		Rondelle Arandela	2
M 	Ø6mm	Douille Plastique Tapón Plástico	1
N 		Rubán Cinta	1

Étape / Paso 1

(FR)

Commençons! Insérez la Cheville (D) dans l'Étagère (2), Panneau Supérieur Central (4), Panneau Inférieur Central (5), Panneau Latéral Gauche (6), Panneau Latéral Droit (7), Pieds (8), Côté Gauche du Tiroir (12) et Côté Droit du Tiroir (13).

(ESP)

Empecemos! Inserte las Espigas (D) en el Estante (2), Panel Superior Central (4), Panel Inferior Central (5), Panel Lateral Izquierdo (6), Panel Lateral Derecho (7), Pies(8), Lado Izquierdo del Cajón (12) y Cajón Lateral Derecho (13).

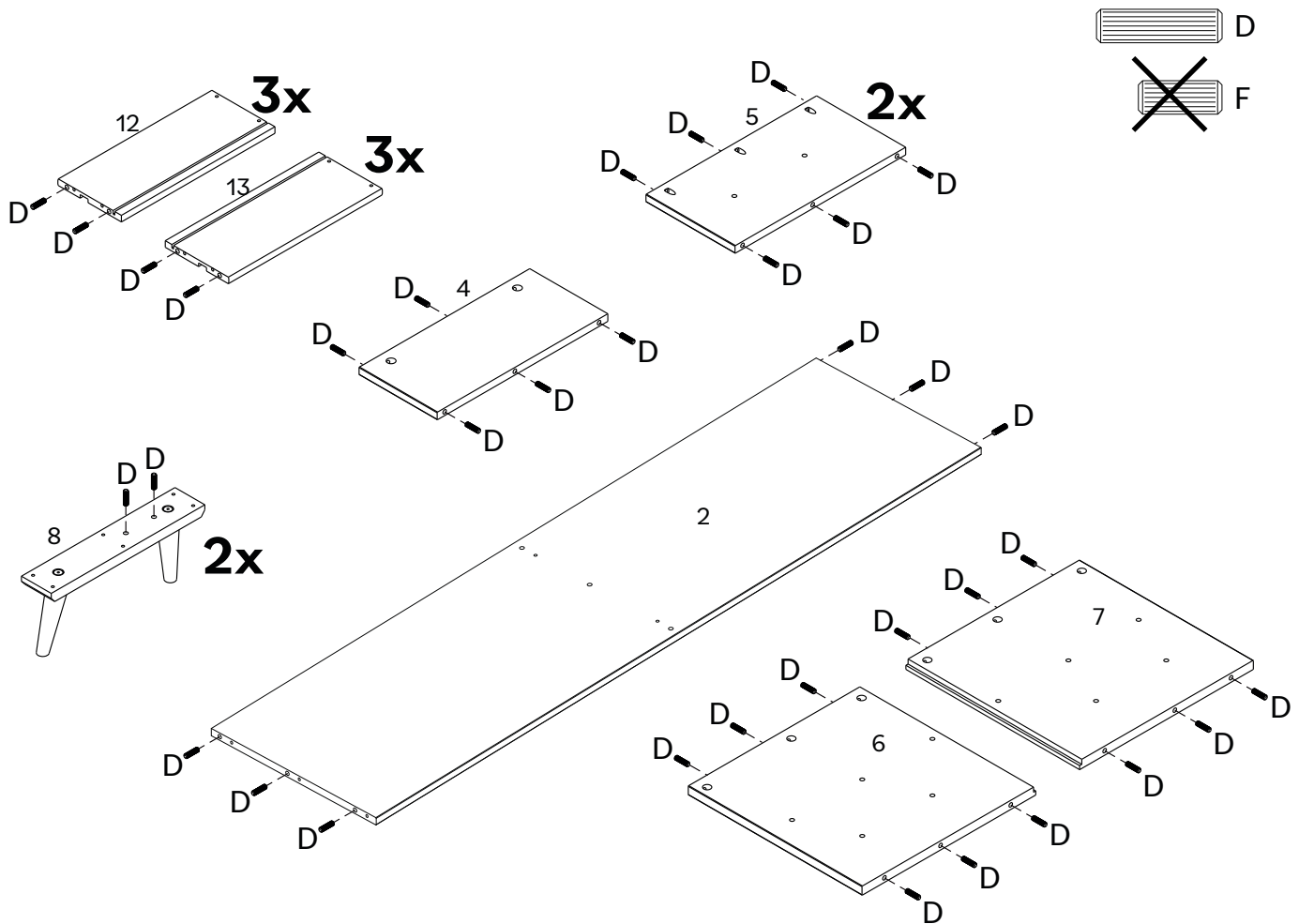

Tip

Cheville en bois

Les chevilles sont essentielles lors de l'assemblage de meubles pour créer des connexions solides et précises. Elles garantissent l'intégrité structurelle, empêchent les déplacements et simplifient l'alignement, ce qui permet d'obtenir des meubles plus résistants et plus durables. suis ces étapes :

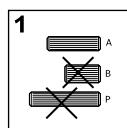

1: Sélectionne la taille de cheville appropriée en fonction de l'étape.
1: Seleccione el tamaño de espiga adecuado según el paso.

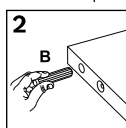

2: Insère dans le trou indiqué et appuie fermement pour assurer un positionnement correct.
2: Insértela en el orificio indicado y presione firmemente para asegurar su correcta colocación.

Espiga de madera

Las espigas son esenciales en el montaje de muebles para crear uniones fuertes y precisas.

Garantizan la integridad estructural, evitan el desplazamiento y simplifican la alineación, lo que se traduce en muebles más resistentes y duraderos.

Sigue estos pasos:

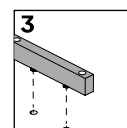

3: Alinee la cheville avec la pièce correspondante et enfonce-la jusqu'à ce qu'elle soit ferme.
3: Alinee el pasador con la pieza correspondiente y presiónelo hasta que encaje.

Étape / Paso 2

(FR)

Insérez la Cheville (F) dans la Glissière (17). Fixez la Glissière (17) dans le Panneau Gauche (6) et le Panneau Droit (7) à l'aide de la Vis (I) et d'un tournevis Phillips.

(ESP)

Inserte la Espiga (F) en la Corredera (17). Fije la Corredera (17) al Panel Izquierdo (6) y al Panel Derecho (7) usando el Tornillo (I) y un destornillador Phillips.

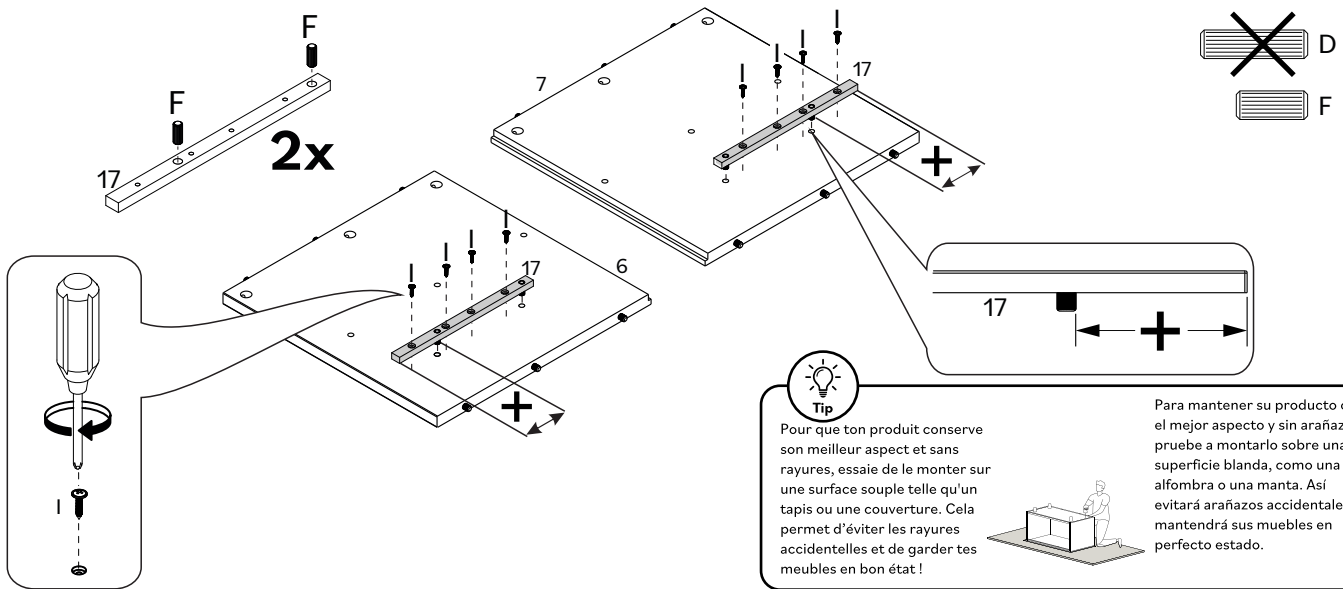

Étape / Paso 3

(FR)

Insérez la Cheville (F) dans la Glissière (17). Fixez la Glissière (17) dans le Panneau Inférieur Central (5) à l'aide de la Vis (I) et d'un tournevis Phillips. Effectuez cette étape deux fois.

(ESP)

Inserte la Espiga (F) en la Corredera (17). Fije la Corredera (17) al Panel Inferior Central (5) usando el Tornillo (I) y un destornillador Phillips. Complete este paso dos veces.

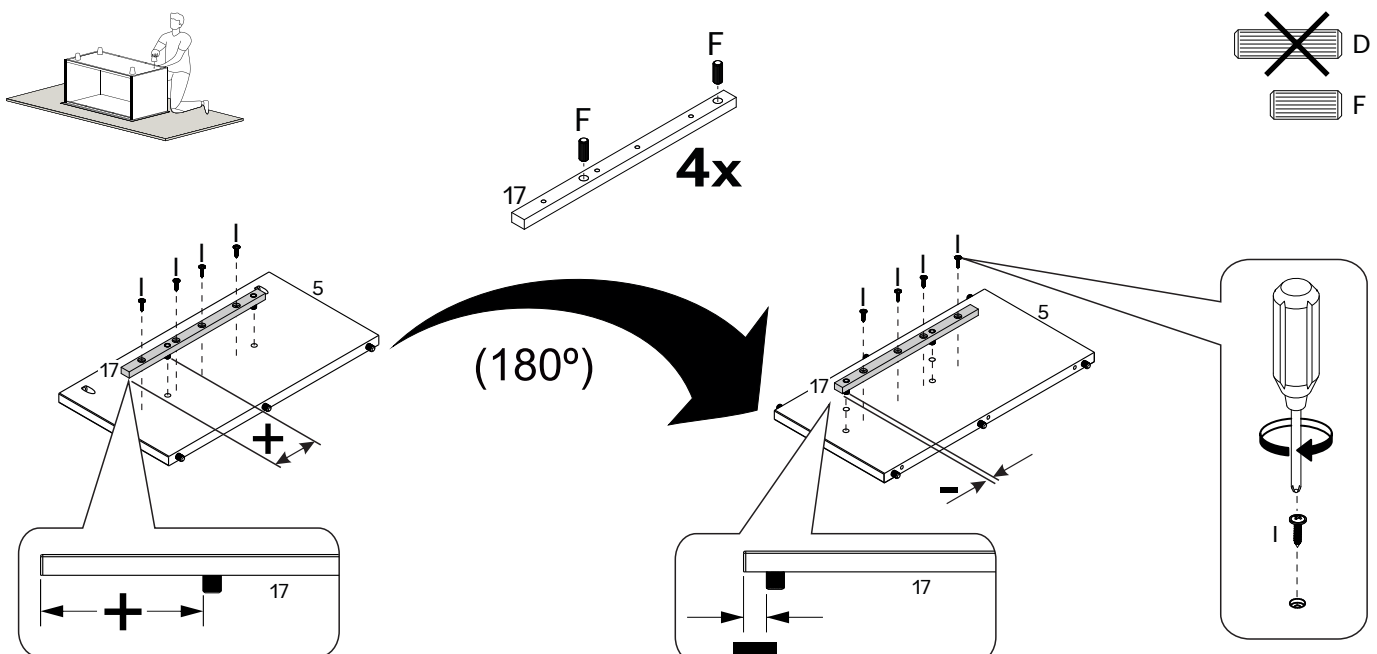

Étape / Paso 4

(FR)

Fixez l'Étagère (2) dans les trous du Panneau Supérieur Central (4) à l'aide de la Vis (G) et d'un tournevis Phillips.

(ESP)

Coloque el Estante (2) en los agujeros del Panel Superior Central (4) usando el Tornillo (G) y un destornillador Phillips.

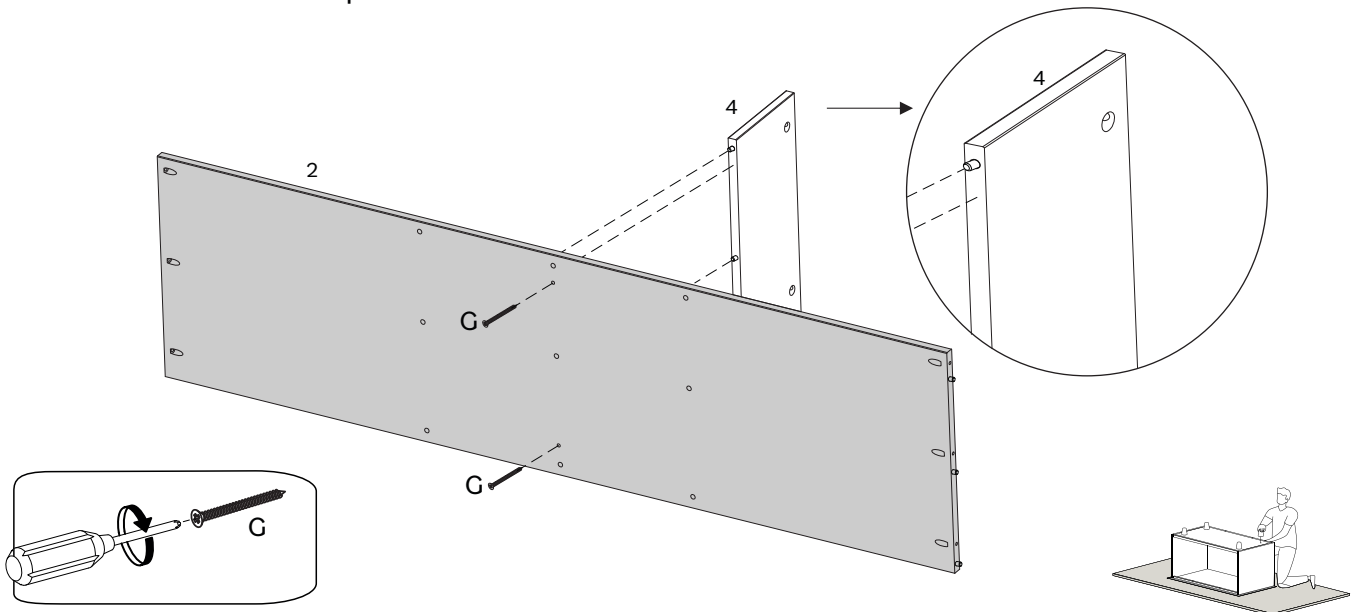

Étape / Paso 5

(FR)

Fixez le Panneau Inférieur Central (5) dans les trous de l'Étagère (2) à l'aide de la Vis (C) et d'un tournevis Phillips.

(ESP)

Coloque el Panel Inferior Central (5) en los agujeros del Estante (2) usando el Tornillo (C) y un destornillador Phillips.

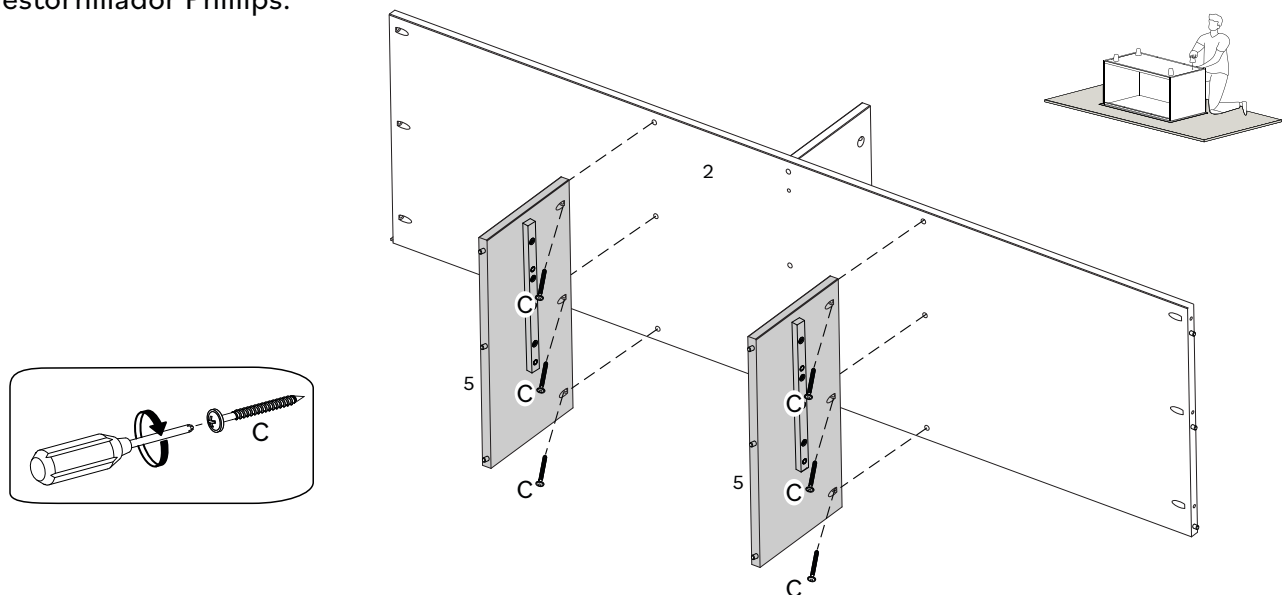

Étape / Paso 6

(FR)

Fixez le Panneau Gauche (6) et le Panneau Droit (7) dans le Étagère (2) à l'aide de la Vis (C) et d'un tournevis Phillips.

(ESP)

Coloque el Panel Izquierdo (6) y el Panel Derecho (7) en la Estante (2) usando el Tornillo (C) y un destornillador Phillips.

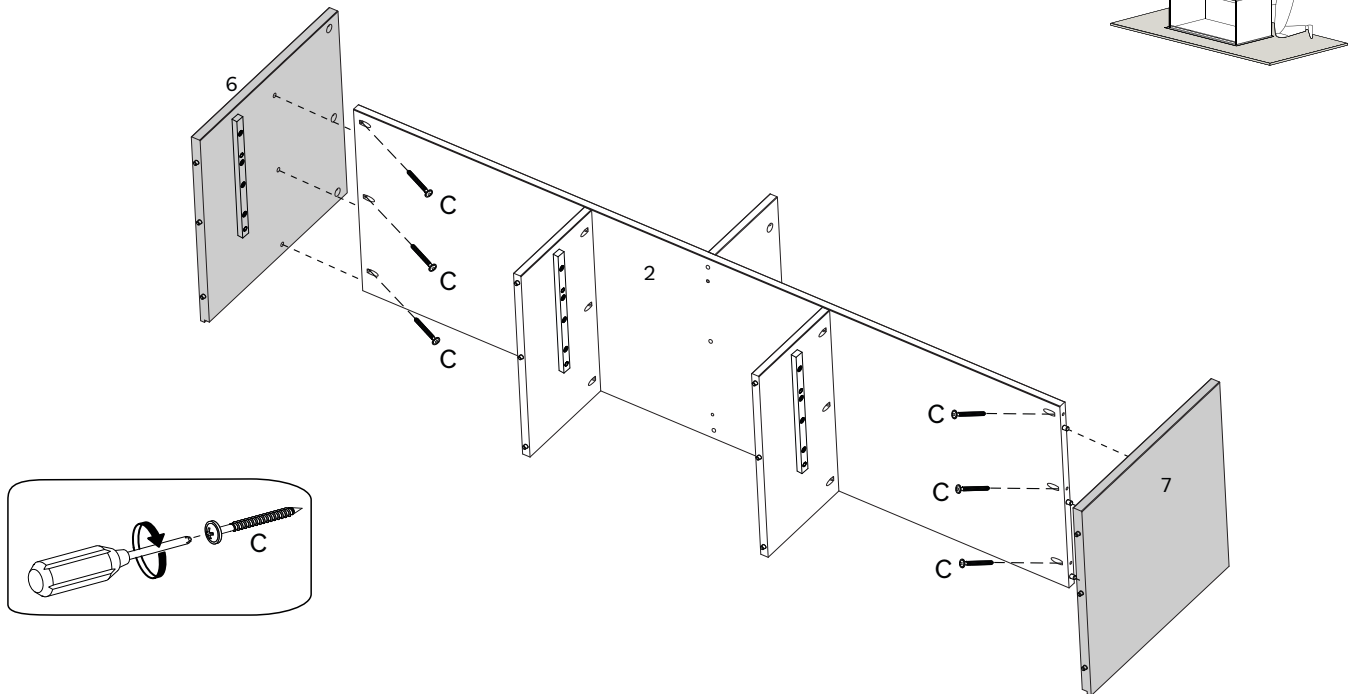

Étape / Paso 7

(FR)

Fixez le Boitier de Assemblage (A) dans les trous du Panneau Supérieur (1) à l'aide d'un tournevis Phillips.

(ESP)

Coloque la Traba del Conector (A) en los agujeros del Panel Superior (1) usando un destornillador Phillips.

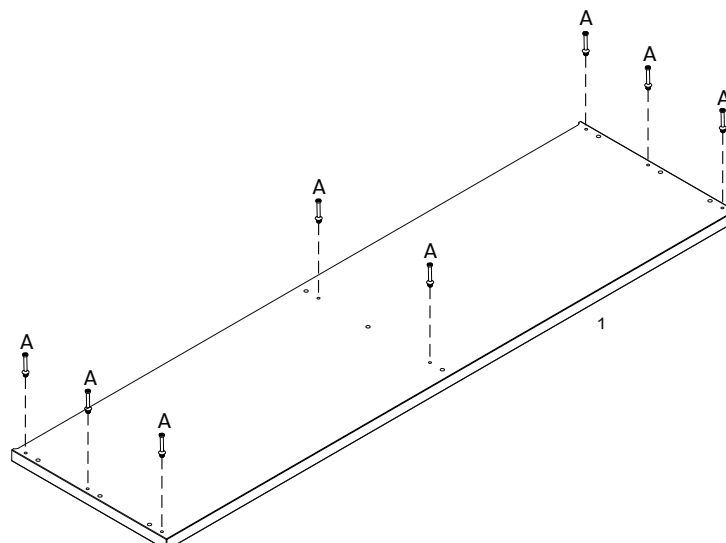
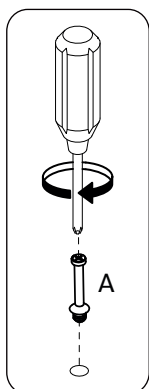

Étape / Paso 8

(FR)

Fixez les Pieds (8) à le Panneau Inférieur (3) à l'aide de la Vis (C) et d'un tournevis Phillips.
Utilisez la Vis (I) pour fixer le Limiteur de Tiroir (J) à le Panneau Central (3).

(ESP)

Coloque los Pies (8) en la Panel Central (3) usando un Tornillo (C) y un destornillador Phillips.
Use el Tornillo (I) para colocar el limitador del cajón (J) en el Panel Inferior (3).

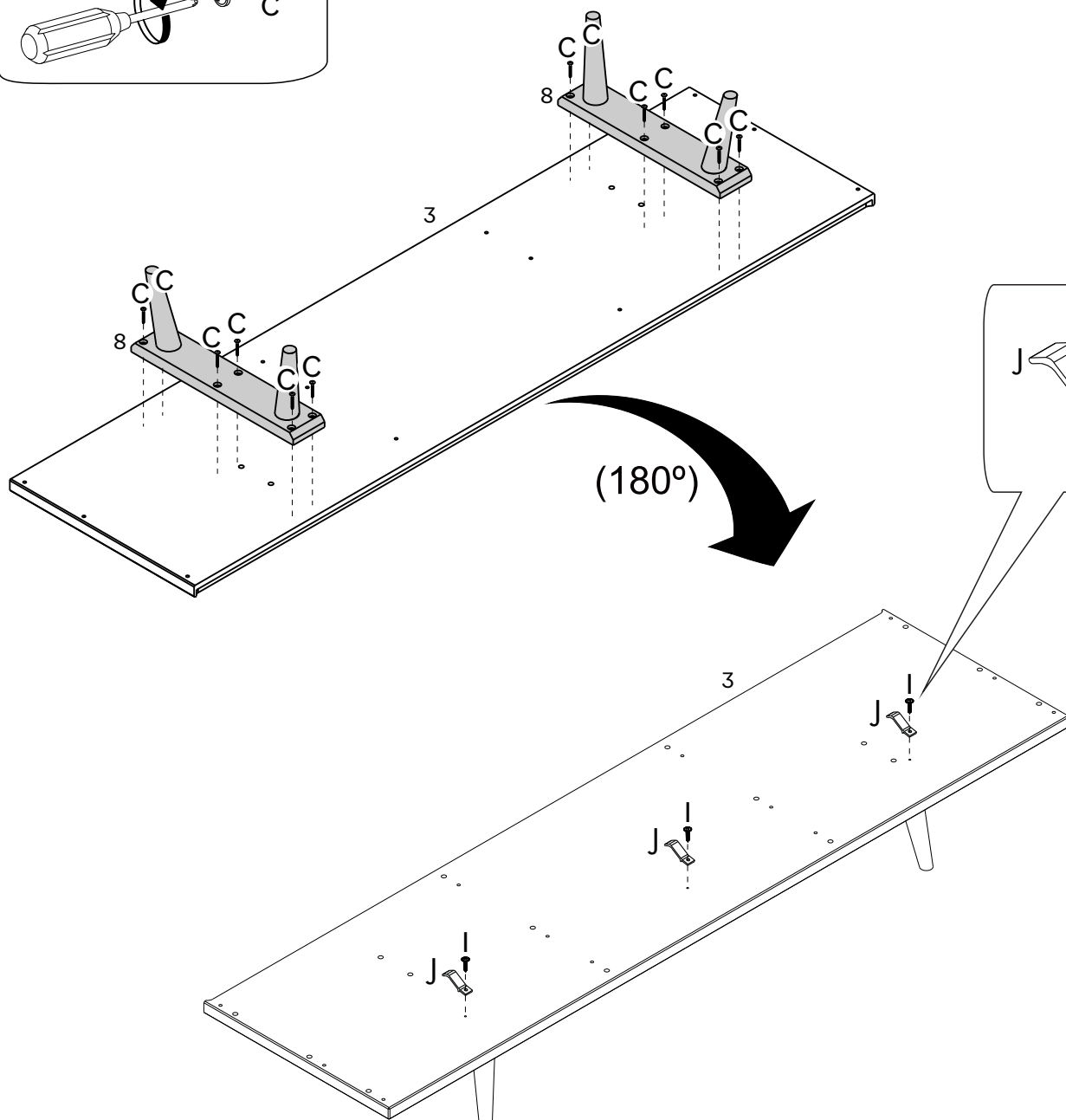
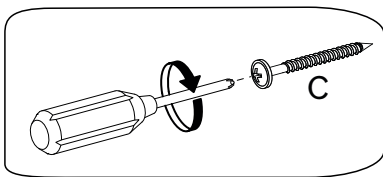
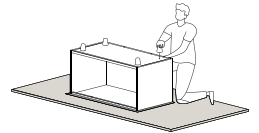

Étape / Paso 9

(FR)

Fixez le Panneau Supérieur (1) et la Panneau Inférieur (3) dans les Chevilles du Panneau Gauche (6) et du Panneau Droit (7) à l'aide de la Vis (G) et du Boitier de Assemblage (B) et d'un tournevis Phillips.

(ESP)

Coloque el Panel Superior (1) y le Panel Inferior (3) en las Espigas del Panel Izquierdo (6) y el Panel Derecho (7) usando el Tornillo (G), la Traba del Conector (B) y un destornillador Phillips.

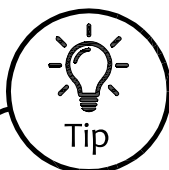
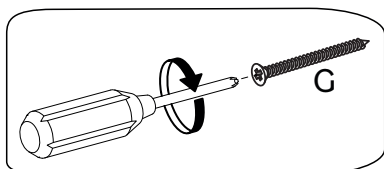
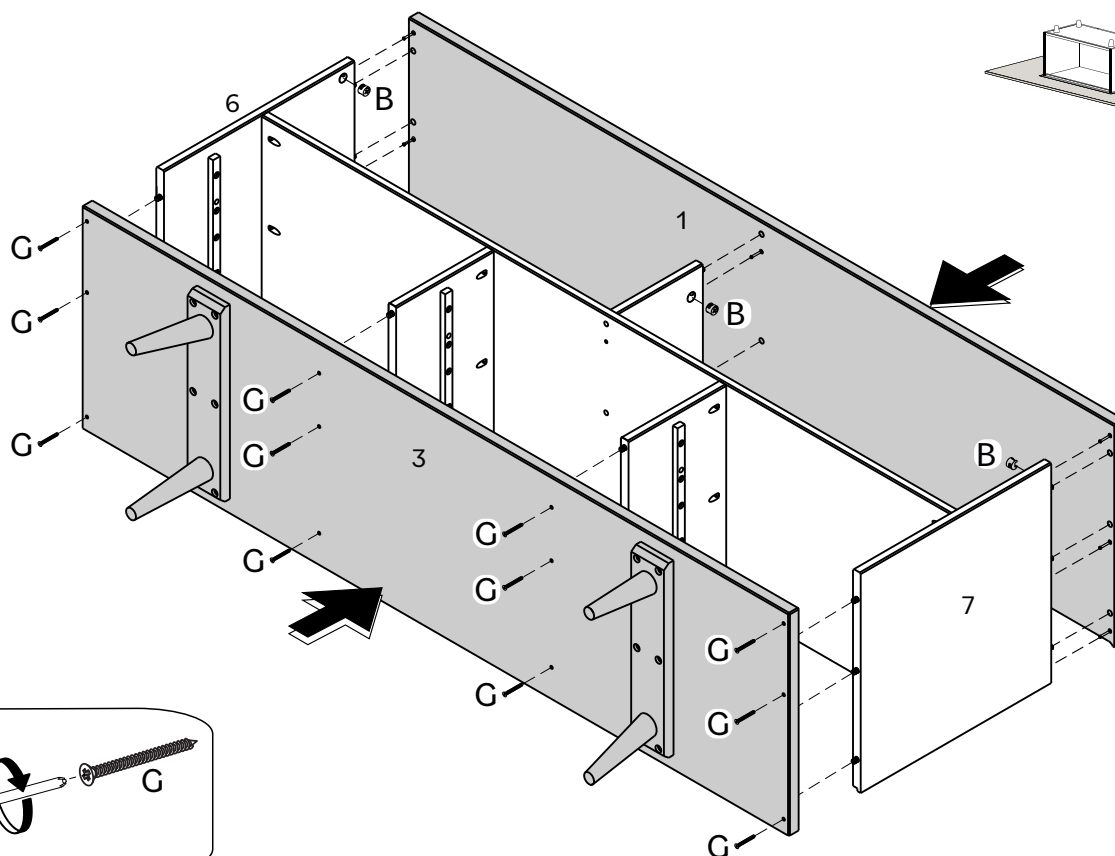

Tip

Goujon

Goujon permet de joindre deux pièces en toute sécurité.

Suis ces étapes simples.

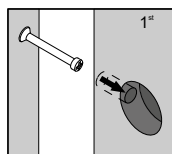

1: Insère le Goujon dans les orifices du côté plat. Ne serre pas trop!

1: Coloca el Conector en los orificios del lado plano. ¡No aprietes demasiado!

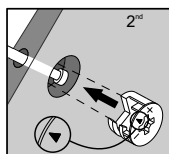

2: Joins les pièces en bois. Les Goujons entrent dans les orifices qui ont des trous sur les côtés, tu dois pouvoir voir les Goujons à travers ceux-ci. Après avoir installé les pièces, insère le Boitier dans les orifices latéraux.

2: Una las piezas de madera. Los Conectores entran en las piezas que tienen agujeros en los lados, por lo que deberías poder ver los Conectores a través de ellos. Después de encajar las piezas, inserta la Traba del Conector en los orificios laterales.

Conector

Los Conectores ayudan a unir de forma segura dos piezas. Sigue estas fáciles etapas.

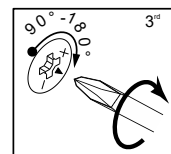

3: Sur la partie arrière du Boitier, il aura la forme d'un « C ». Insère le Boitier de manière à ce que l'ouverture « C » s'emboîte à la Conector. Serre-la avec le tournevis.

3: La parte posterior de la Traba tendrá la forma de "C". Inserta la Traba de modo que la abertura de la "C" encaje en el Conector. Apriétalo con un destornillador.

Étape / Paso 10

(FR)

Fixez le Panneau Arrière Supérieur (9) et le Panneau Arrière (10) à l'aide de la Vis (I) et du Plaque (H) et d'un tournevis Phillips.

(ESP)

Fije el Panel Trasero Superior (9) y el Panel Posterior (10) con el Tornillo (I) y las Placas (H) y un destornillador Phillips.

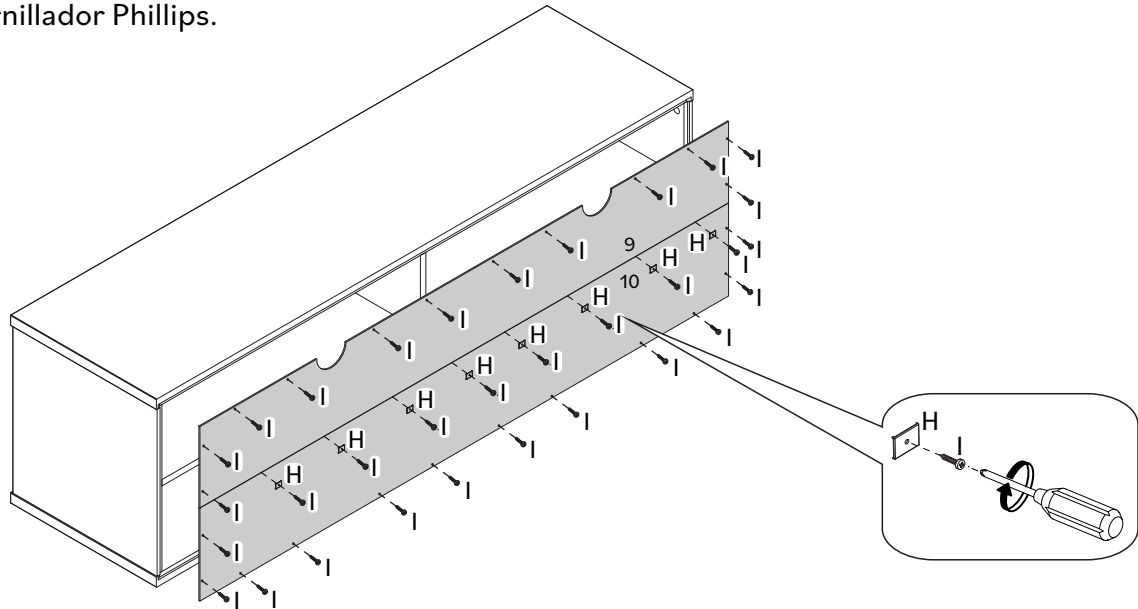

Étape / Paso 11

(FR)

Fixez le côté gauche du tiroir (12) et le côté droit du tiroir (13) dans la façade du tiroir (11) à l'aide de la vis (C) et d'un tournevis cruciforme. Insérez le fond du tiroir (14). Fixez le côté gauche du tiroir (12) et le côté droit du tiroir (13) au Arrière du tiroir (15) à l'aide de la vis (C) et d'un tournevis cruciforme.

(ESP)

Coloque el lado izquierdo del cajón (12) y el lado derecho del cajón (13) en el frente del cajón (11) usando el tornillo (C) y un destornillador Phillips. Inserte la parte inferior del cajón (14). Fije el lado izquierdo del cajón (12) y el lado derecho del cajón (13) en el Trasero del cajón (15) usando el tornillo (C) y un destornillador Phillips.

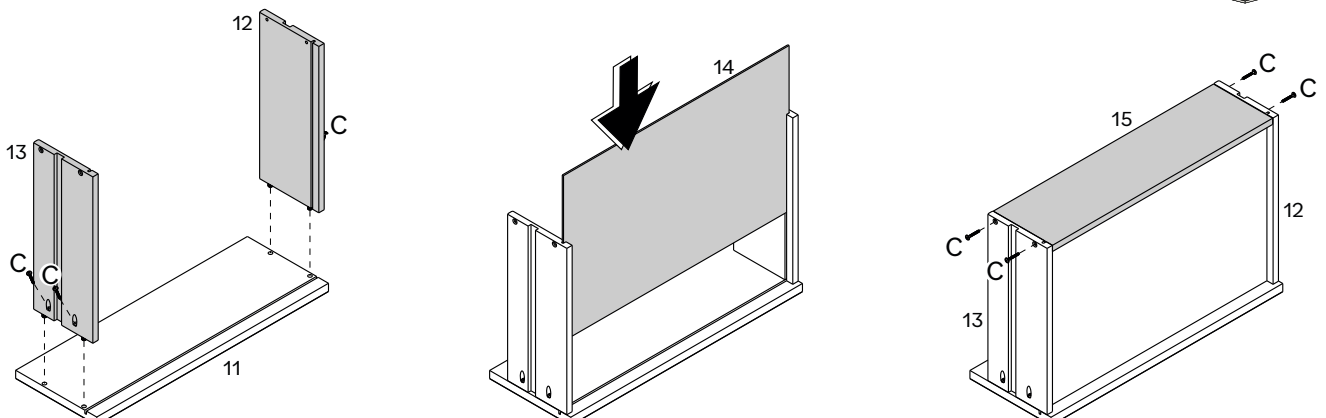
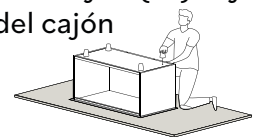

Étape / Paso 12

(FR)

Pour terminer, fixons votre support TV au mur! Fixez l'Rubán(N) à votre support TV à l'aide d'une rondelle (L) et d'une vis (I).

(ESP)

Para finalizar, ¡fijemos el soporte de TV a la pared! Fije la Cinta (N) al soporte de TV con una arandela (L) y un tornillo (I).

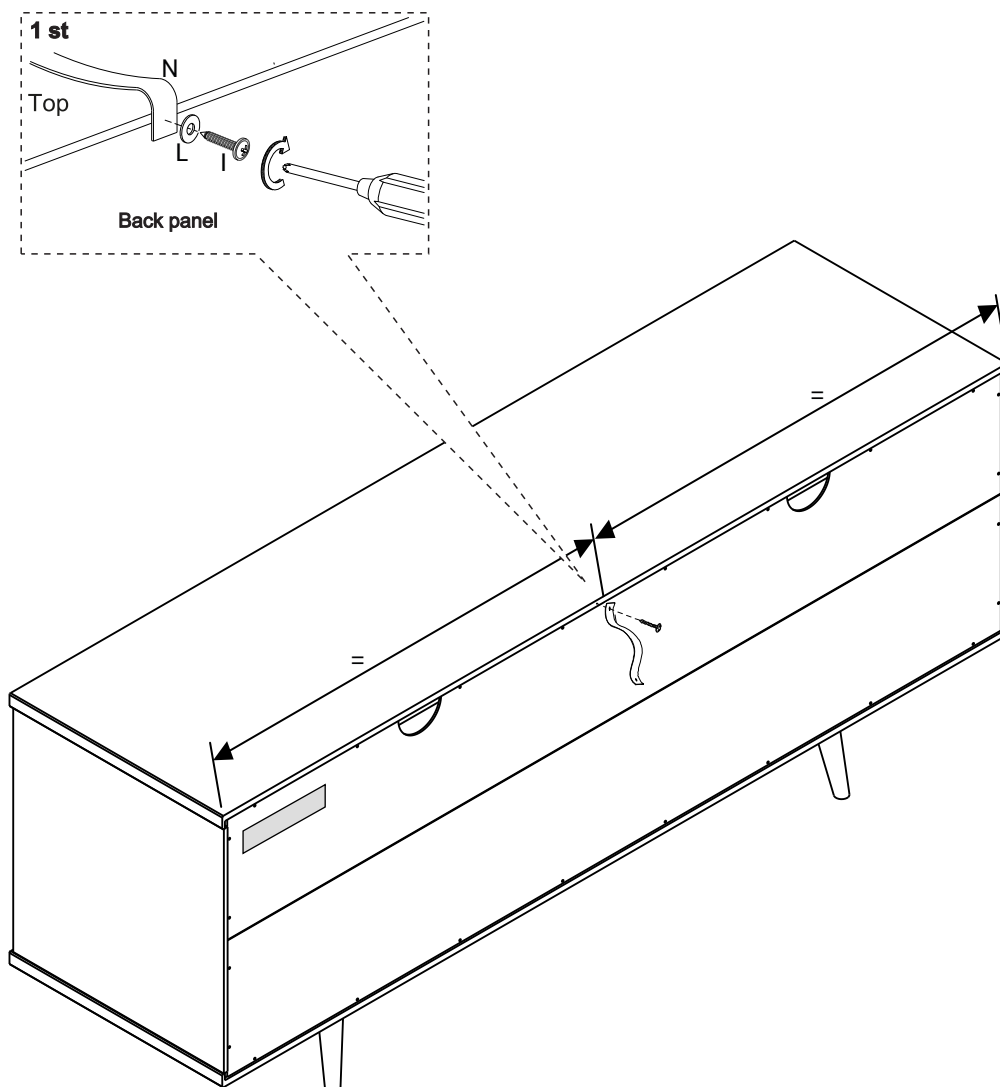

Step 13

(FR)

Insérez la douille en plastique (M) dans le mur. Ensuite, fixez l'ancrage mural (N) au mur à l'aide d'une rondelle (L) et d'une vis (K).

(ESP)

Inserte el Tapón de plástico (M) en la pared. Luego, fije el anclaje de pared (N) a la pared con una arandela (L) y un tornillo (K).

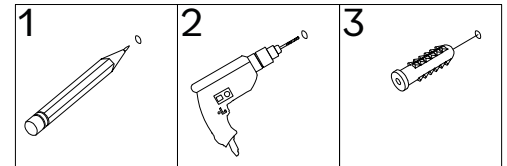
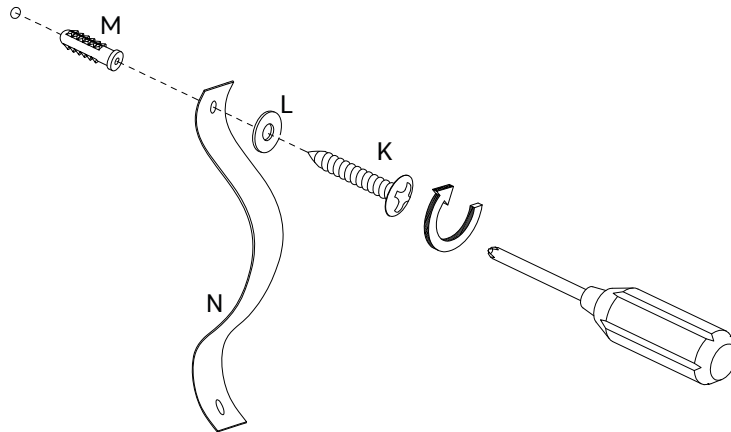

AVERTISSEMENT

Des blessures graves, voire mortelles, peuvent survenir en cas de renversement. Pour éviter le renversement, installez les dispositifs de retenue selon les instructions. Si vous l'utilisez pour prendre en charge un téléviseur ou un moniteur :

- La mort ou des blessures graves peuvent survenir lorsque des enfants grimpent sur des meubles d'équipement audio/vidéo. Des télécommandes ou des jouets placés sur le meuble peuvent inciter un enfant à grimper sur le meuble et par conséquent sur le meuble.
- Ne placez pas le téléviseur près du bord avant du produit.

Pour réduire davantage le risque de blessures graves et de décès dus à un renversement :

- Placez les objets les plus lourds dans les compartiments ou tiroirs les plus bas.
- Ne laissez jamais les enfants grimper ou s'accrocher aux tiroirs, aux portes ou aux étagères.
- N'ouvrez jamais plus d'un tiroir à la fois.

L'utilisation de dispositifs de sécurité en cas de basculement peut seulement réduire, mais pas éliminer, le risque de basculement.

Pour un montage sûr, il est essentiel d'utiliser des ancrages muraux adaptés à votre type de mur (c'est-à-dire plâtre, cloison sèche, béton, etc.). Montez sur des montants en bois autant que possible. Remarque : si vous n'êtes pas sûr de votre type de mur ou de la méthode de montage que vous devez utiliser, consultez un professionnel qualifié ou votre quincaillerie locale.

Informations sur le nom et l'adresse du fabricant responsable du matériel anti-basculement et la date de production se trouvent sur l'étiquette au dos du meuble.

Información de nombre y dirección del fabricante responsable del hardware antivuelco y la fecha de producción se pueden encontrar en la etiqueta en la parte posterior del mueble.

ADVERTENCIA

En caso de vuelco se pueden producir lesiones por aplastamiento graves o mortales. Para ayudar a evitar vuelcos, instale restricciones de vuelco según las instrucciones. Si lo utiliza como soporte para un televisor o monitor:

- Pueden producirse muertes o lesiones graves cuando los niños se suben a los muebles de equipos de audio o vídeo. Los controles remotos o los juguetes colocados sobre los muebles pueden alentar al niño a subirse a los muebles y, como resultado, a los muebles.
- No coloque el televisor cerca del borde frontal del producto.

Para reducir aún más el riesgo de lesiones graves y muerte por vuelcos:

- Coloque los artículos más pesados en los compartimentos o cajones más bajos.
- Nunca permita que los niños trepen o se cuelguen de cajones, puertas o estantes.
- Nunca abra más de un cajón a la vez.

El uso de dispositivos de seguridad contra vuelcos sólo puede reducir, pero no eliminar, el riesgo de vuelco.

Para un montaje seguro, es fundamental utilizar anclajes de pared adecuados para su tipo de pared (es decir, yeso, paneles de yeso, hormigón, etc.). Monte en montantes de madera siempre que sea posible. Nota: si no está seguro del tipo de pared o del método de montaje que debe utilizar, consulte a un profesional cualificado o a su ferretería local.

Tu as réussi! Profite de ton nouveau TV Stand!
¡Lo ha conseguido! ¡Disfrute de su nueva TV Stand!

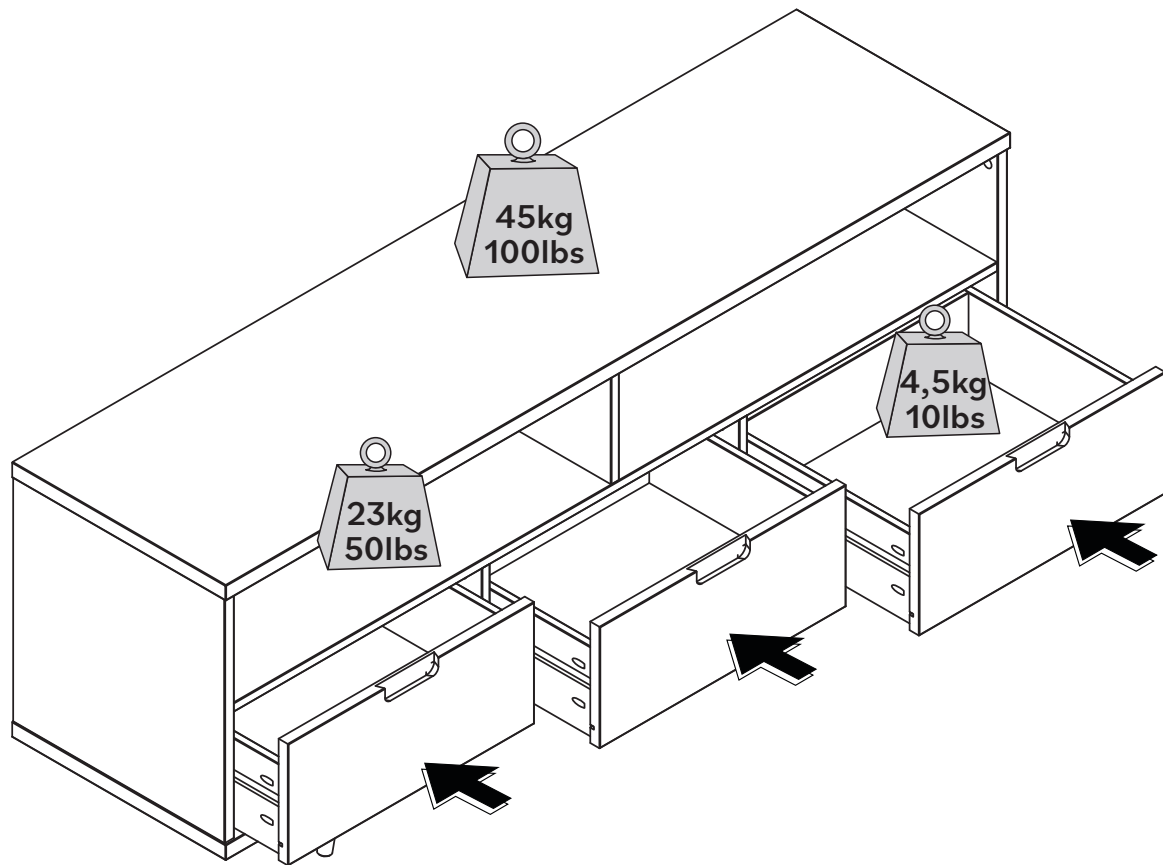

Bravo pour ton nouveau meuble !

Nous aimerions t'en entendre parler et le voir.

S'il te plait, laisse-nous un commentaire ou publie une photo sur

#mywalkerredisonhome

¡Enhorabuena por sus nuevos muebles!

Nos encantaría oírlo y verlo.

Por favor, déjenos un comentario o publique una foto con

#mywalkerredisonhome

Assembler des meubles peut parfois être compliqué.

Notre équipe de service client, située dans l'Utah, est là pour obtenir des informations sur les produits, aider pour l'assemblage d'un produit ou pour tout autre problème de support client.

Appelle-nous **801-433-3008**

Envoie-nous les e-mails à service@walkeredison.com

Visite notre site accueil au client à

walkeredison.com/pages/customer-service

Nous sommes disponibles pour t'aider du Lundi au Jeudi de 8 am - 5 pm, Vendredi de 8 am - 3 pm MST

Pour plus de détails sur les vidéos d'assemblage, les instructions d'assemblage, les pièces de rechange et le service client.

NUMÉRISER ICI.



Pour le nettoyage, n'utilise jamais d'abrasifs, utilise un chiffon doux et de l'eau avec du savon neutre pour nettoyer les meubles.

A veces, montar muebles puede resultar complicado.

Nuestro equipo de atención al cliente, ubicado en Utah, está a su disposición para informarle sobre los productos, ayudarlo a montarlos o resolver cualquier otro problema de atención al cliente.

Llámenos **801-433-3008**

Envíenos un correo electrónico a service@walkeredison.com

Visite nuestra página web de atención al cliente

walkeredison.com/pages/customer-service

Estamos a su disposición para ayudarlo de lunes a jueves de 8:00 a 17:00, viernes de 8:00 a 15:00 MST.

Para más detalles sobre videos de montaje, instrucciones de montaje, piezas de recambio y servicio de atención al cliente

ESCANEE AQUÍ.



Para la limpieza, nunca utilice productos abrasivos, utilice un paño suave y agua con jabón neutro para limpiar los muebles.