

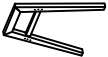









Thank you for purchasing this quality product. Be sure to check all packing materials carefully for small parts, which may have come loose inside the carton during shipment. Identify and count all items and compare with the PARTS LIST and/or HARDWARE LIST shown below.

1. We recommend that you assemble this product with the assistance of another person; this will make the assembly easier, and will help eliminate damage to the product or injury to persons during assembly.
2. Please do not tighten screws or bolts until assembly is completed.
3. To level the chairs or table, before tightening all the screws, the chairs or table must be placed on a flat surface and then tighten the screws.
4. Please put all parts on a non-abrasive floor before assembly and follow the assembly steps to assemble your newly purchased product correctly and efficiently.

PARTS LIST			
NO.	DESCRIPTION	SKETCH	QTY
A	BACKREST		1 PC
B	LEFT SIDE FACING (LSF) LEG		1 PC
C	RIGHT SIDE FACING (RSF) LEG		1 PC
D	FRONT APRON (LONG)		1 PC
E	BACK APRON (SHORT)		1 PC
F	SEAT CUSHION		1 PC

HARDWARE LIST			
NO.	DESCRIPTION	SKETCH	QTY
1	JCBC BOLT 1/4"x2"		12 PCS
2	FLAT WASHER		12 PCS
3	SPRING WASHER		12 PCS
4	ALLEN KEY		1 PC
5	PLASTIC DOWEL		8 PCS

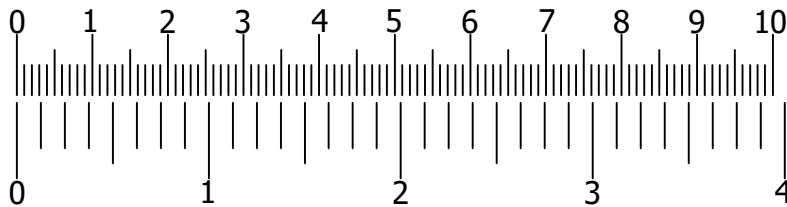

WEIGHT CAPACITY (PER CHAIR)	243 LBS
-----------------------------	---------

STEP 1:

Insert the Plastic Dowels (5) into the pre-drilled holes at each end of the Front Apron (D) and Back Apron (E).

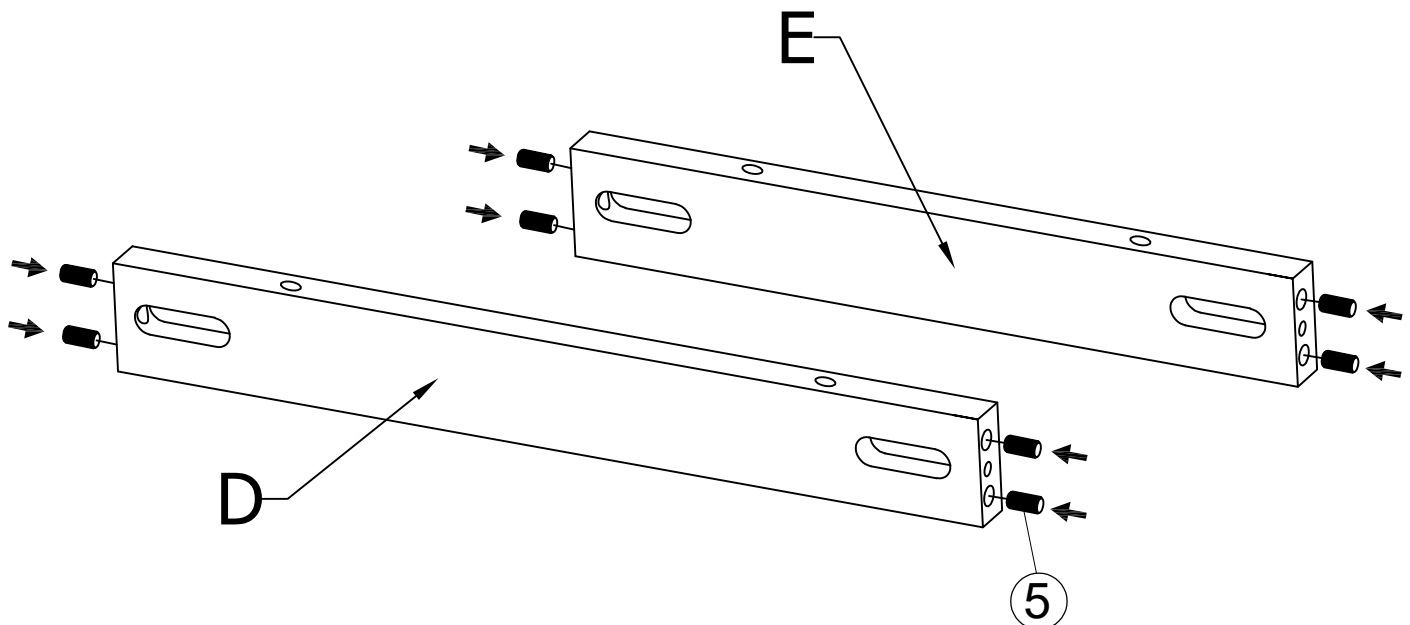

STEP 2:

Assemble the RSF Leg (B) and LSF Leg (C) with the Front Apron (D) and Back Apron (E) by using Allen Key (4) with Hardware 1,2 & 3.

*** DO NOT OVERTIGHTEN THE BOLTS**

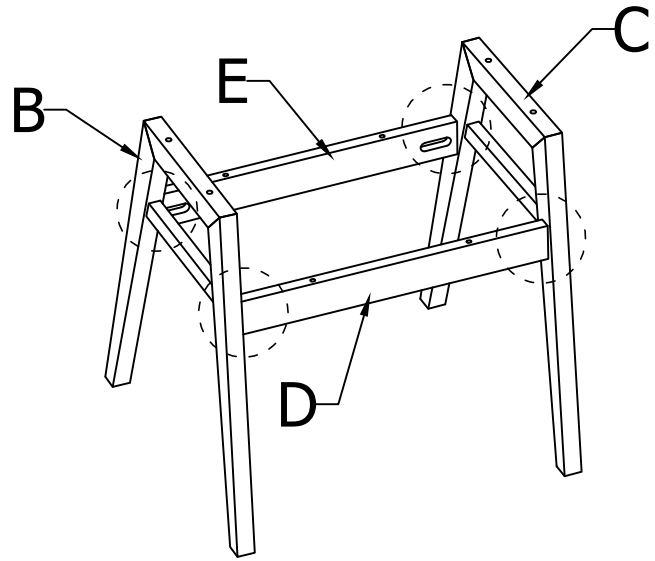
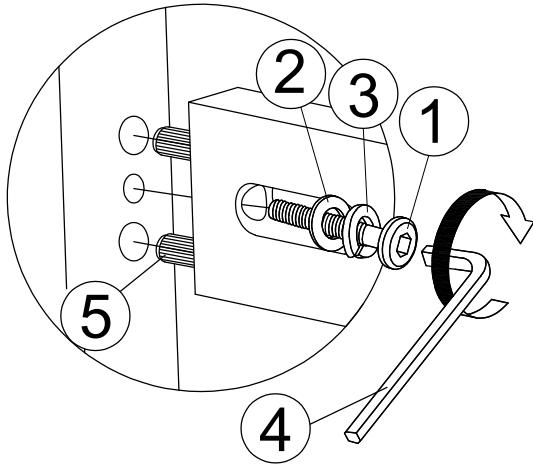

STEP 3:

Place the Backrest (A) on a flat and clean surface. Align and assemble RSF Leg (B) and LSF Leg (C) to the Backrest (A) by using Allen Key (4) with Hardware 1,2 & 3.

*** DO NOT OVERTIGHTEN THE BOLTS**

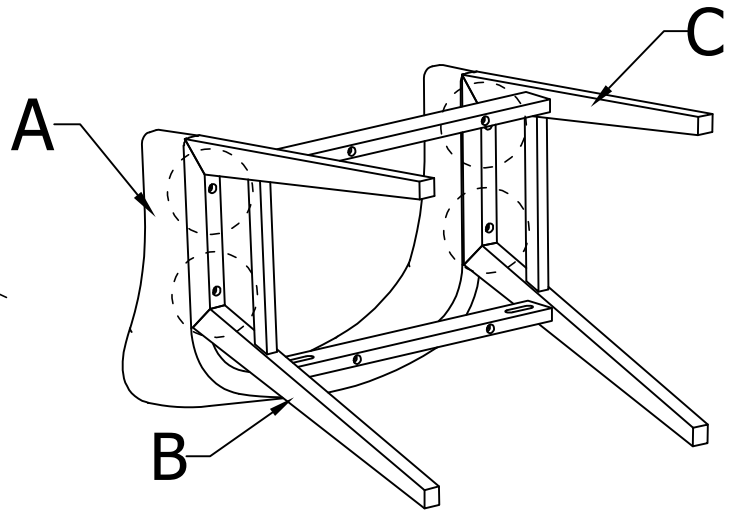
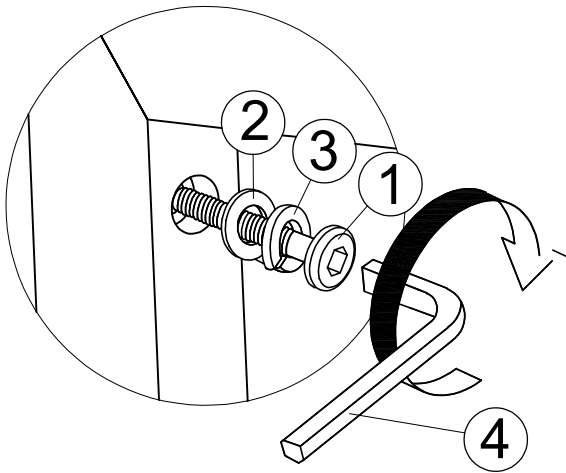

STEP 4:

Place the chair upside down with the legs facing up to assemble the Front Apron (D) and Back Apron (E) to the Backrest (A) by using Allen Key (4) with Hardware 1,2 & 3.

*** DO NOT OVERTIGHTEN THE BOLTS**

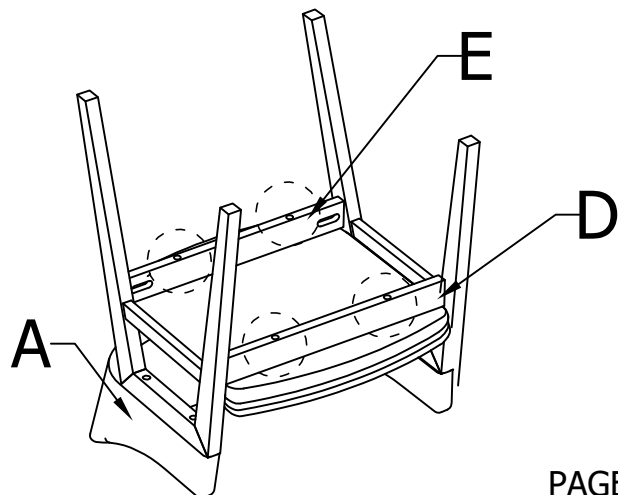
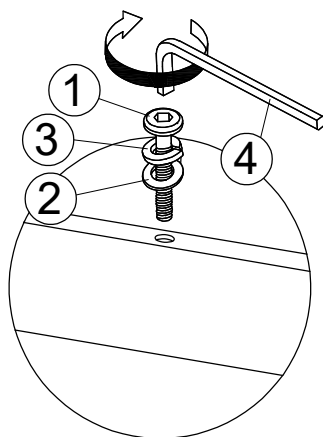

STEP 5:
Complete.

