

# 5.0-Liter Round Container with EZ Cover®

## Multiple Uses

Dry Products

## Product Codes

Container: **K056**

Description: 5.0-liter round can

Cover: **KTDZ**

Description: Tamper-evident, round EZ Cover®

## Features

Gauge: 55 mil.

Nominal capacity: 5.0 L / 1.32 USG

Stack performance: 150 lbs.\*

Tare weights: Body: .51 lbs. / .23 kgs.

Cover: .19 lbs. / .08 kgs.

Note: \*Ratings will be reduced with uneven load distribution.

## Specifications with Cover

Dimensions: 8-3/8"D X 7-15/16"H

Maximum capacity: 5.2 L / 1.37 USG

Tare weight: .70 lbs. / .31 kgs.

## Colors

Standard: White and Natural

Custom: Available at manufacturer's discretion

## Decorating Options

Silk - Screening: 24"W X 4"H

Four or six\* color offset printing

Print area: 24"W X 5"H

Note: \*Where available

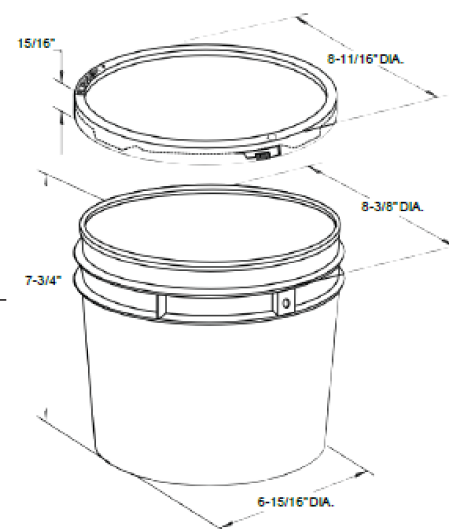

## Shipping Data

Qty. per pallet:

400

3,600 (18 boxes of 200)\*

150 (25 per layer/6 layers high)

Gross Weight (lbs./kgs.)\*\*:

204/92

684/288

Pallet height: 50.9"

Den. (lbs./C.F./kgs./m3):

4.7/74.6

8.6/127.9

Length (in./cm.):

48/121.9

53/134.6

Width (in./cm.):

43/109.2

36/91.4

Height (in./cm.):

36.5/92.7

72/182.9

Estimated truckload quantity of 17,600 bodies and covers\*\*\*

Notes: \*Bulk pack also available

\*\*Weight does not include pallet/packaging

\*\*\*Truckload quantity based on 53' trailer

## Materials

FDA approved materials

Resin: Body: High-Density Polyethylene (HDPE)

Cover: High-Density Polyethylene (HDPE)

MSDS Sheets available upon request

## Optional Carrying Handle

### DISCLAIMER

THIS INFORMATION IS PROVIDED AS A GENERAL GUIDE, INCLUDING DIMENSIONS. IT IS THE CUSTOMER'S RESPONSIBILITIES TO SELECT THE PROPER CONTAINER FOR PRODUCT AND APPLICATION COMPATIBILITY.

DISTRIBUTED BY:



REF NO.:

DWG10140

DESCRIPTION:

5 liter HDPE Open Head Pail