







# HEKMAN

## ASSEMBLY INSTRUCTIONS

23323 - SIDE CHAIR WOOD BACK

**X** A HOWARD MILLER COMPANY

A		13mm	P c
B		5 / 16 " x	1 2 P s 6 x 8 . 5 m m
C		5 / 16 "	9 P s
D		x 3 9 / 16 "	9 P s
E		x 3 8 / 16 "	1 P s
F		x 3 8 / 16 "	4 P s
H		5mm	P c

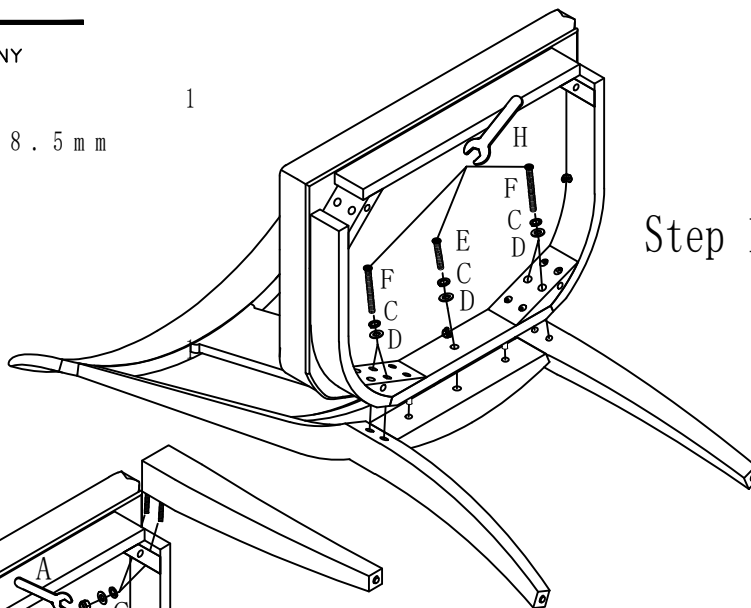

Step 1

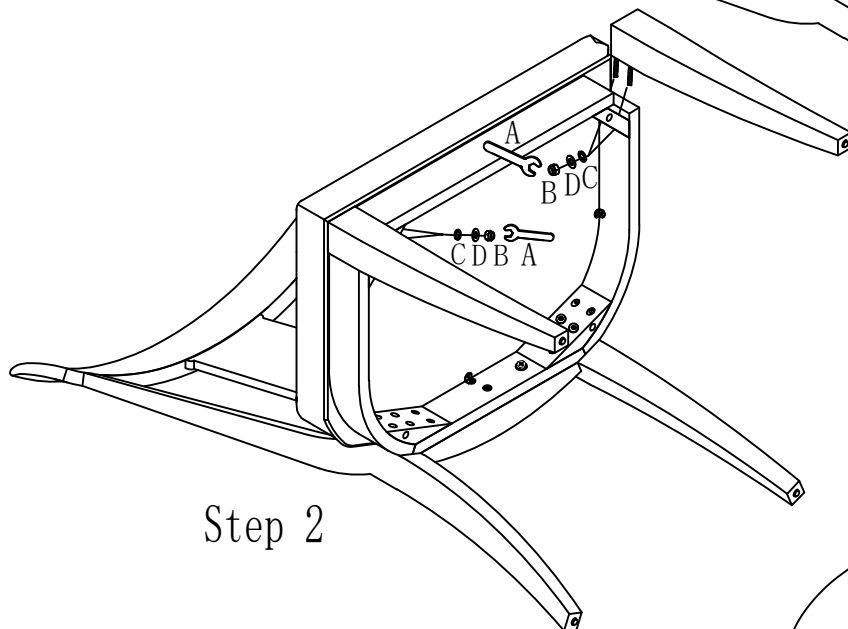

Step 2

Assemble the chair on soft and clean surface to prevent scratching. Loosen screws holding upholstered seat to seat apron assembly, it's not necessary to remove the seat completely.

Step 1: Assemble the back frame and the chair seat together with Bolt (E, F), Spring Washer (C) and Flat washer (D) using Wrench (H).

Step 2: Assemble the front legs to the chair with Hex Nut (B), Spring Washer (C) and Flat washer (D) using Wrench (A). Do Not tighten the screws or nuts completely.

Step 3: Set the chair upright on a flat surface. Adjust the front legs so all four chair legs touch the floor, tighten nuts completely on the front legs. The seat cushion may need to be loosen to adjust the front legs.

Step 4 - tighten screws holding seat cushion to apron assembly.

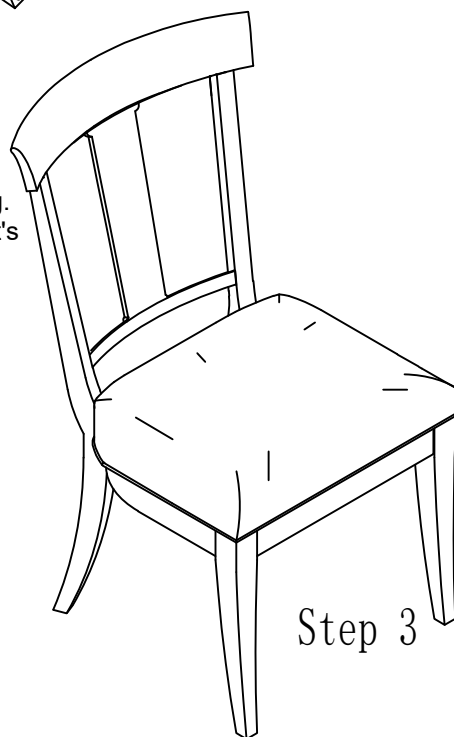

Step 3

MADE IN CHINA