

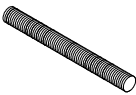







# HEKMAN®

A HOWARD MILLER COMPANY

## 28523 TRESTLE WRITING DESK

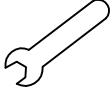
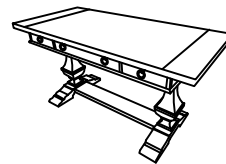
HARDWARE LIST							
A	B	C	D	E	F	G	H
THREADED ROD M8 x 100 (2 PCS.)	HALF WASHER M8 (2 PCS.)	HEXAGON NUTS M8 (2 PCS.)	ALLEN BOLT M8 X 40 (8 PCS)	FLAT W. M8 (8 PCS.)	LOCK W. M8 (8 PCS.)	ALLEN KEY L5 (FOR ALLEN BOLT) (1 PC.)	WRENCH (FOR HEXA BOLT) (1 PC.)
							

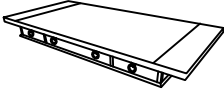

PART INSIDE		
1	2	3
TOP ASSEMBLY (1 Pc)	LEG ASSEMBLY (2 Pcs)	STRETCHER (1 Pc)
		

### Assembly Instruction

#### STEP 1:

INSERT THREADED ROD (A) INTO INSERT IN LEG ASSEMBLIES (2). PLACE STRETCHER (3) IN POSITION AND LOCK WITH HALFMOON WASHER (B), HEXAGON NUTS (C) USING WRENCH (H) PROVIDED.

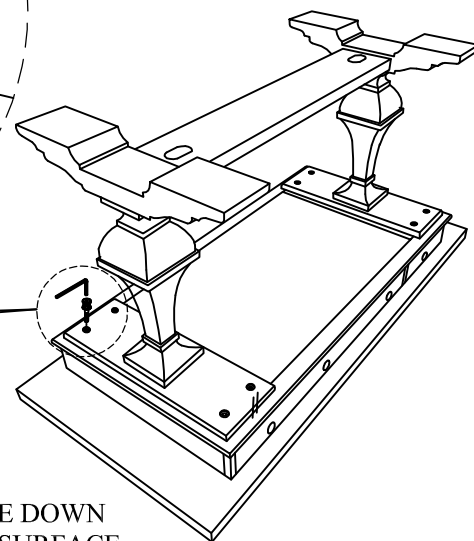
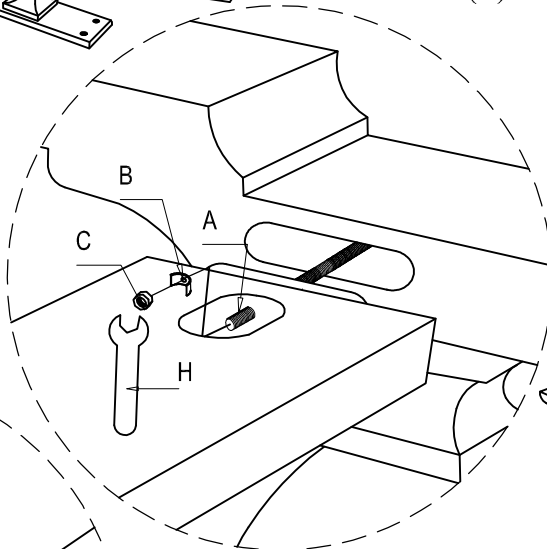
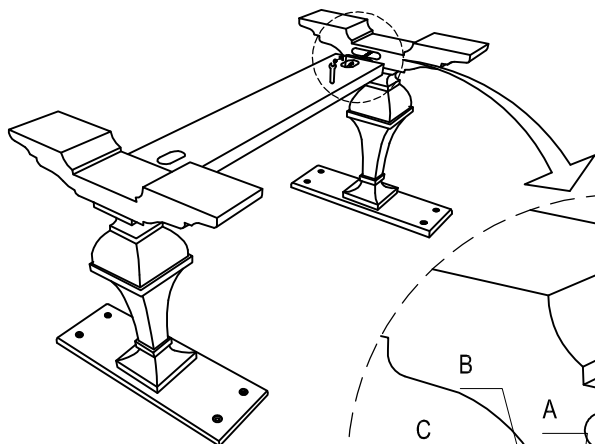

#### STEP 2.

LAY TOP ASSEMBLY (1) UPSIDE DOWN ON A SOFT, CLEAN AND FLAT SURFACE. ALIGN THE HOLES IN THE TOP PLATE OF THE LEG ASSEMBLIES WITH THE INSERT IN THE BOTTOM PANEL OF THE TOP ASSEMBLY. CONNECT USING FLAT WASHER (E), LOCK WASHER (F), ALLEN BOLT (D) AND ALLEN KEY (G) PROVIDED.

