

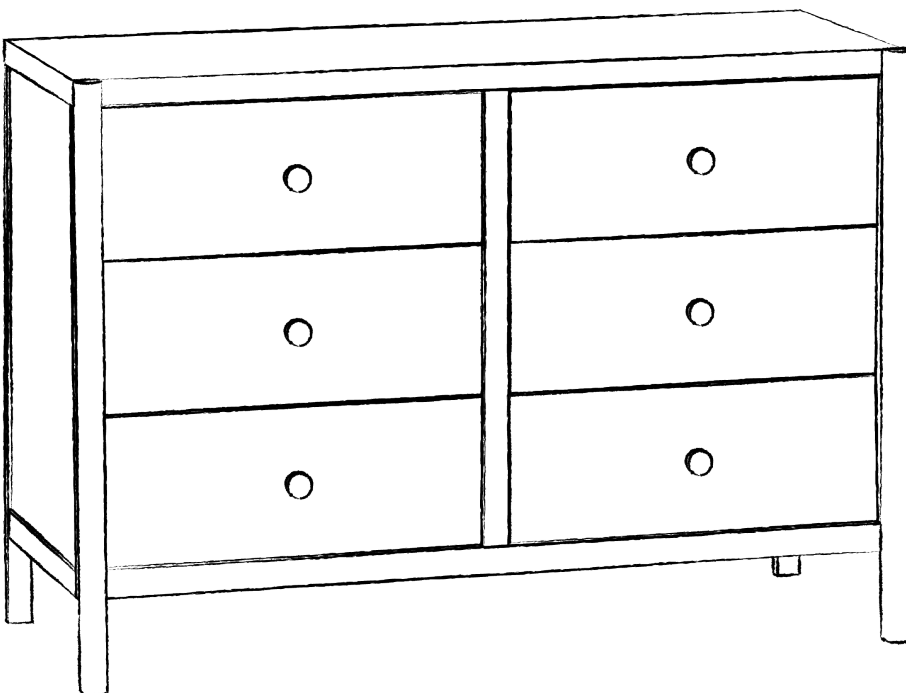

Birdie

M25126





Hi!



Pregnancy is a wild journey. We get it!

At DaVinci we're obsessed with your child's safety, so you can focus on welcoming your baby home. Let's get started—it's time to set up the perfect space for your little one.

When you're settled in, be sure to share your family's milestones @davincibabyusa. We love connecting with our families!

You've got this!
DaVinci



¡Hola!

El embarazo es toda una odisea. ¡Lo entendemos!

En DaVinci estamos obsesionados con la seguridad del bebé, para que usted pueda enfocarse en darle la bienvenida a su hogar. Comencemos—es hora de preparar el espacio perfecto para su pequeño.

Cuando tenga tranquilidad, no olvide compartir sus hitos familiares con @davincibabyusa. ¡Nos encanta conectar con nuestras familias!

¡Eso es!
DaVinci



Bonjour!

La grossesse est ponctuée de hauts et de bas. Nous en sommes conscients!

Chez DaVinci, nous sommes obnubilés par la sécurité de votre enfant, vous pouvez donc vous concentrer sur l'arrivée de votre bébé à la maison. Mettons-nous au travail — il est temps d'aménager l'environnement idéal pour votre tout-petit.

Une fois que vous serez installés, n'hésitez pas à partager les étapes importantes de votre vie de famille sur @davincibabyusa. Nous adorons rester en contact avec les familles!

Voilà!
DaVinci



**GETTING
STARTED**

**PARA
COMENZAR**

**POUR
COMMENCER**

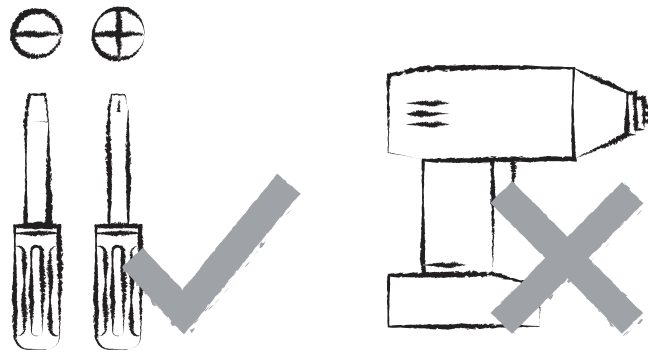
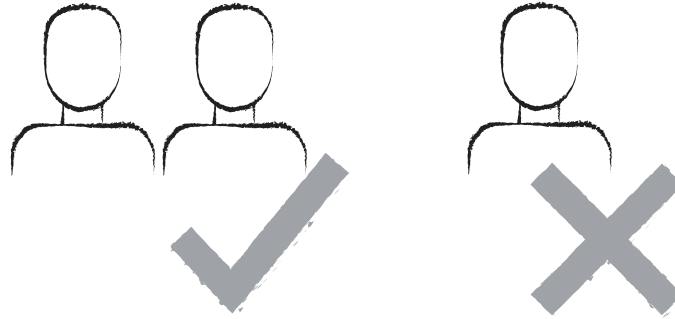

We'd love to chat with you (we're parents ourselves!), so don't hesitate to contact us with whatever questions you have.



Nos encantaría conversar con usted (¡también somos padres!), por eso no deje de contactarnos si tiene alguna pregunta.



Nous adorons discuter avec vous (nous sommes nous-mêmes des parents!), alors n'hésitez pas à nous contacter pour quelque question que ce soit.

DAVINCIBABY.COM/SUPPORT

(323) 768-0183

PARTS

not to scale

PIEZAS

no a escala

PIÈCES

non dessinées à l'échelle

A

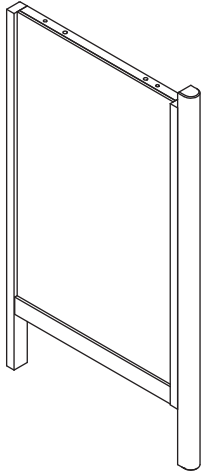

LEFT SIDE PANEL
PANEL LATERAL IZQUIERDO
PANNEAU LATÉRAL GAUCHE

B

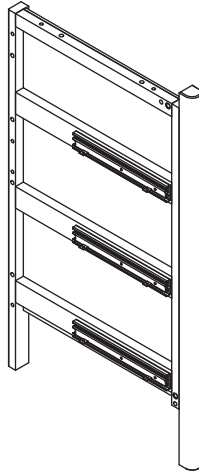

RIGHT SIDE PANEL
PANEL LATERAL DERECHO
PANNEAU LATÉRAL DROIT

C

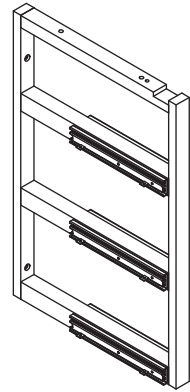

MIDDLE PANEL
PANEL CENTRAL
PANNEAU CENTRE

D

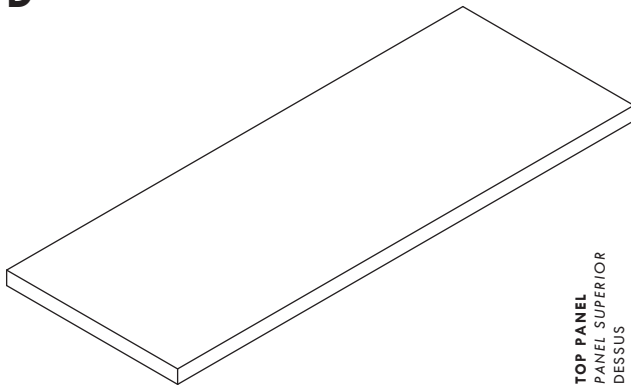

TOP PANEL
PANEL SUPERIOR
DESSUS

E

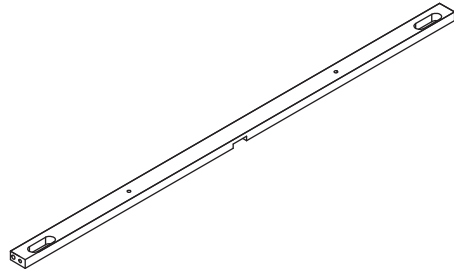

FRONT TOP SUPPORT RAIL
RIEL DE SOPORTE DELANTERO SUPERIOR
TRAVERSÉ DE SUPPORT SUPÉRIEURE AVANT

F

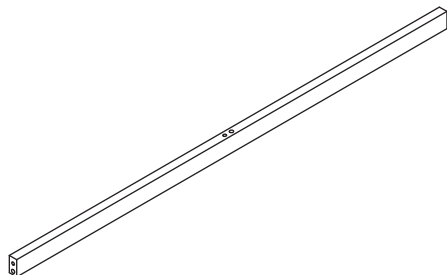

FRONT BOTTOM SUPPORT RAIL
RIEL DE SOPORTE INFERIOR DELANTERO
TRAVERSÉ DE SUPPORT INFÉRIÈRE AVANT

G

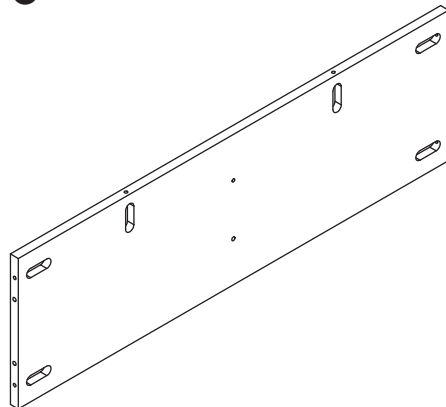

BACK TOP PANEL
PANEL POSTERIOR SUPERIOR
PANNEAU ARRIÈRE SUPÉRIÈRE

J

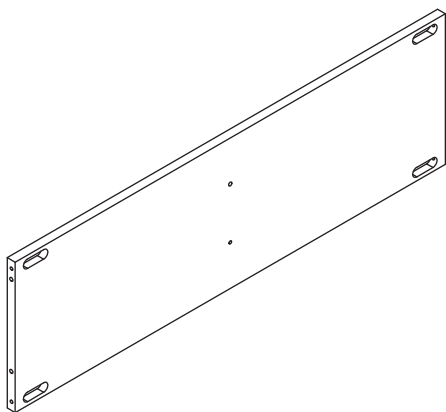

BACK BOTTOM PANEL
PANEL POSTERIOR INFERIOR
PANNEAU ARRIERE INFÉRIEUR

K
x6

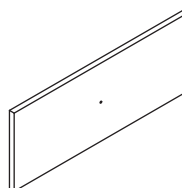

DRAWER FRONT
FRENTE DE CAJÓN
FAÇADE DE TIROIR

L
x6

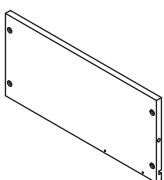

LEFT DRAWER SIDE
LADO DEL CAJÓN IZQUIERDO
CÔTÉ GAUCHE DE TIROIR

M
x6

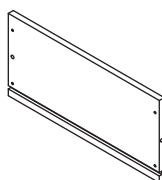

RIGHT DRAWER FRONT
FRENTE DE CAJÓN DERECHO
FAÇADE DROIT DE TIROIR

N
x6

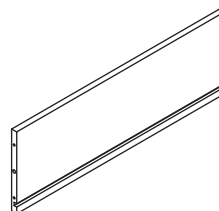

DRAWER BACK
PARTE TRASERA DEL CAJÓN
ARRIÈRE DE TIROIR

P
x6

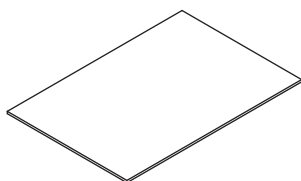

DRAWER BOTTOM
FONDO DE CAJÓN
FOND DE TIROIR

Q



MIDDLE LEG
SOPORTE DEL CENTRO
SUPPORT CENTRAL

HARDWARE

actual size

HERRAJE

tamaño real

MATÉRIEL

taille actuelle

H1
x15

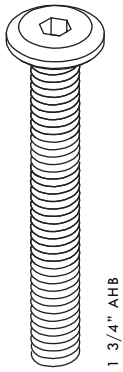

H2
x9

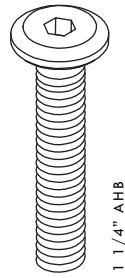

H3
x24

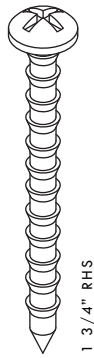

H4
x24

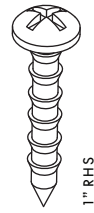

H5
x24



H6
x21



H7
x24



H8
x14

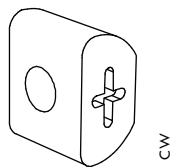

H9
x24



H10
x6

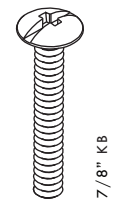

H11

x6

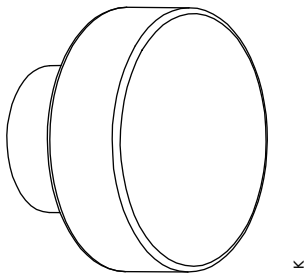

H12

x1

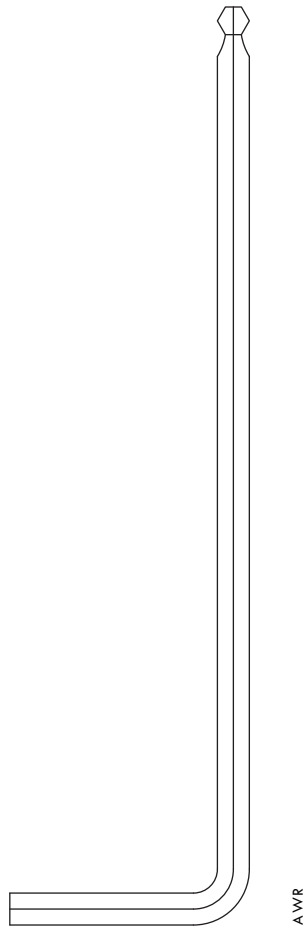

AWR



1

H6
X4

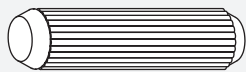

X4

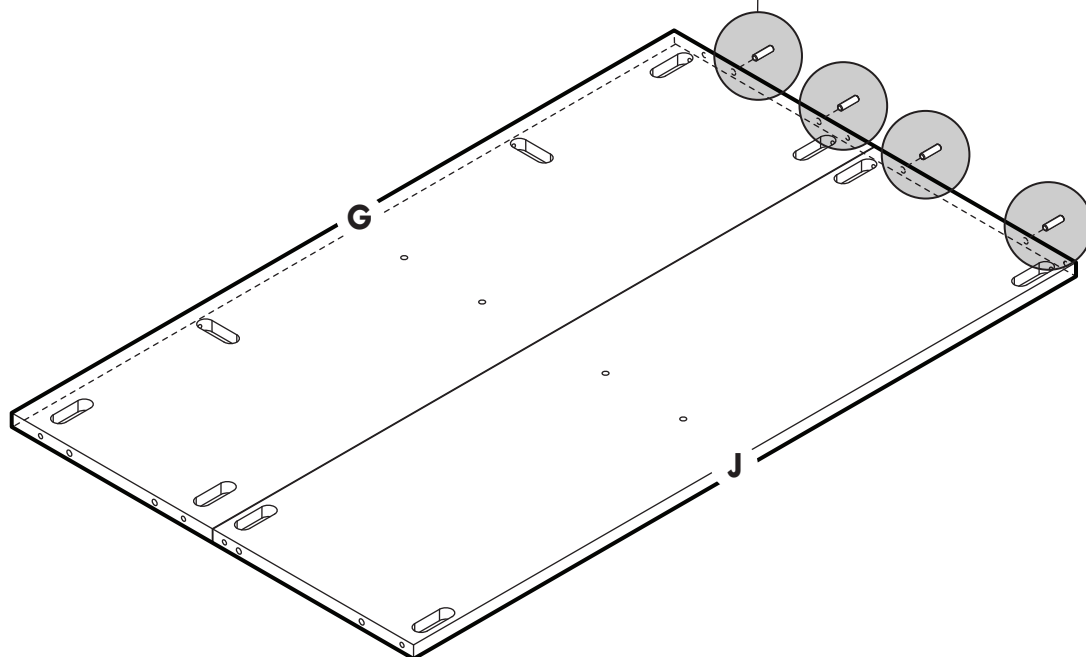
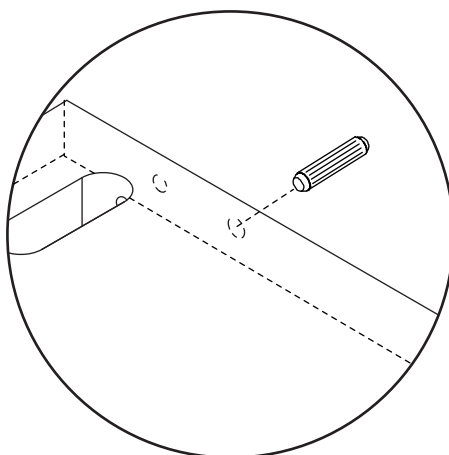

2

H1
X4

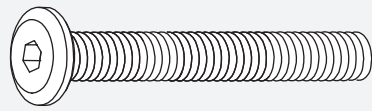

H8
X4

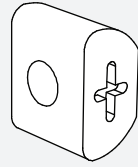

X4

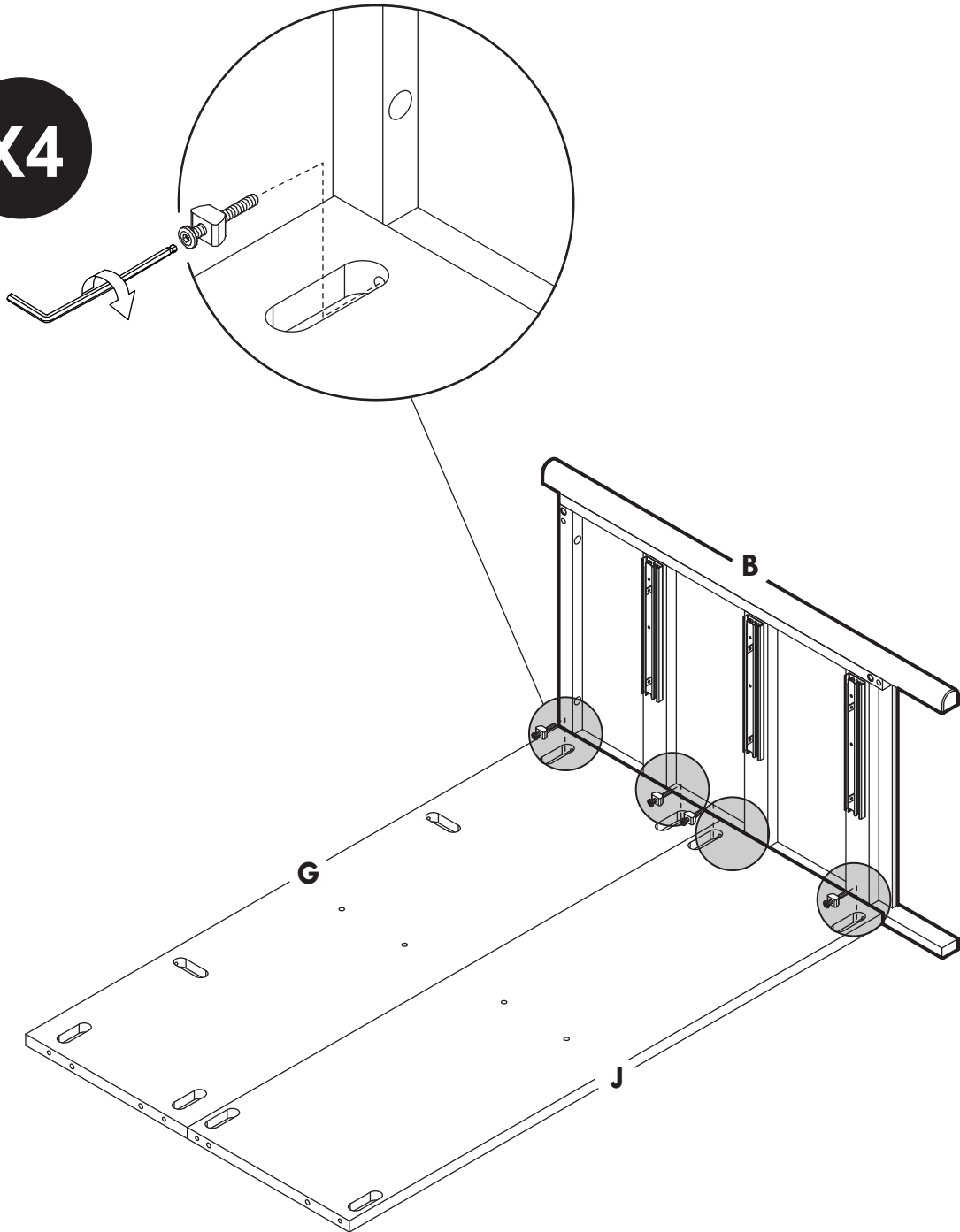

3 OPTIONAL / OPCIONAL / EN OPTION :

Use optional middle leg if you intend to load the dresser with more than 50lbs (22kg) of additional weight or with the changing tray.

Utilice el soporte del centro opcional si tiene la intención de cargar la cómoda con más de 50 libras (22 kg) de peso adicional o con la bandeja para cambiar pañales.

Utilisez le support central optionnel si vous avez l'intention de charger la commode avec plus de 22 kg (50 lb) de poids supplémentaire ou avec le plateau à langer.

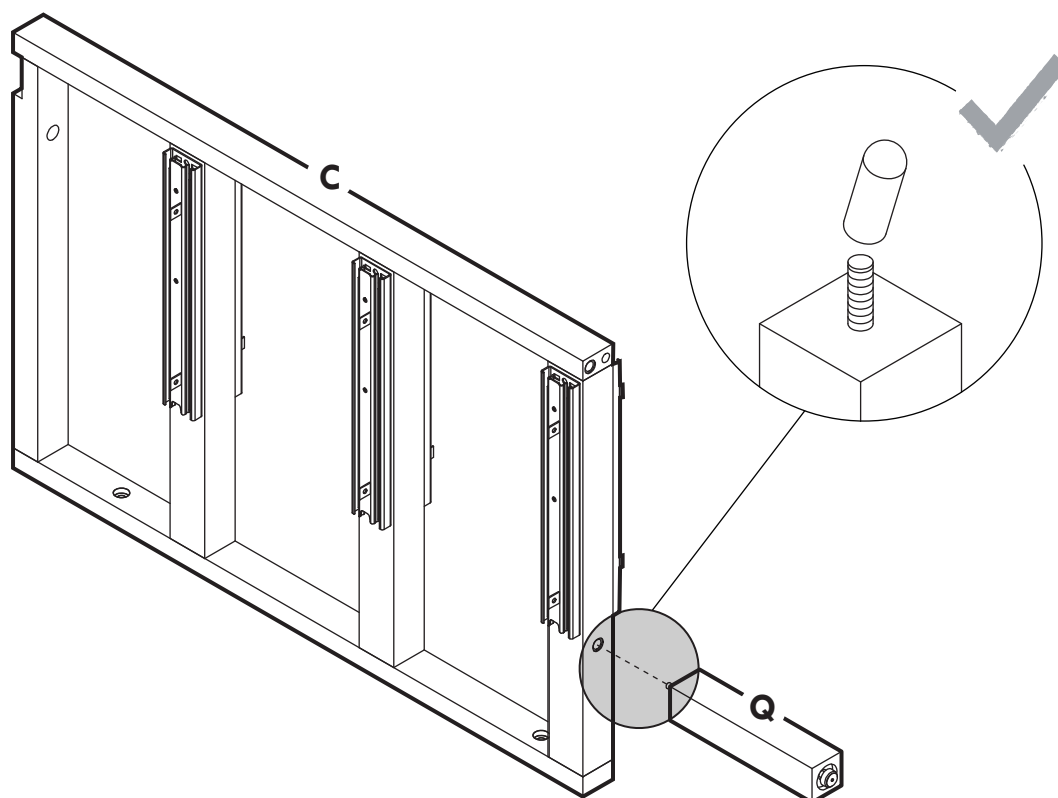

Adjustable screw to help provide stability.

Tornillo ajustable para ayudar a proporcionar estabilidad.

Vis réglable pour aider à assurer la stabilité.

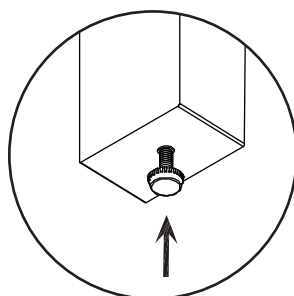

4

H6
X2

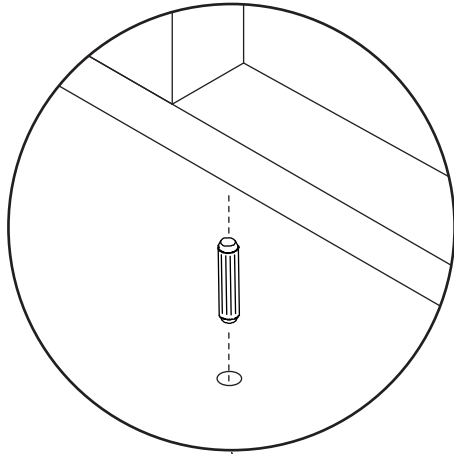
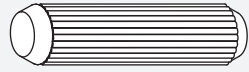

X2

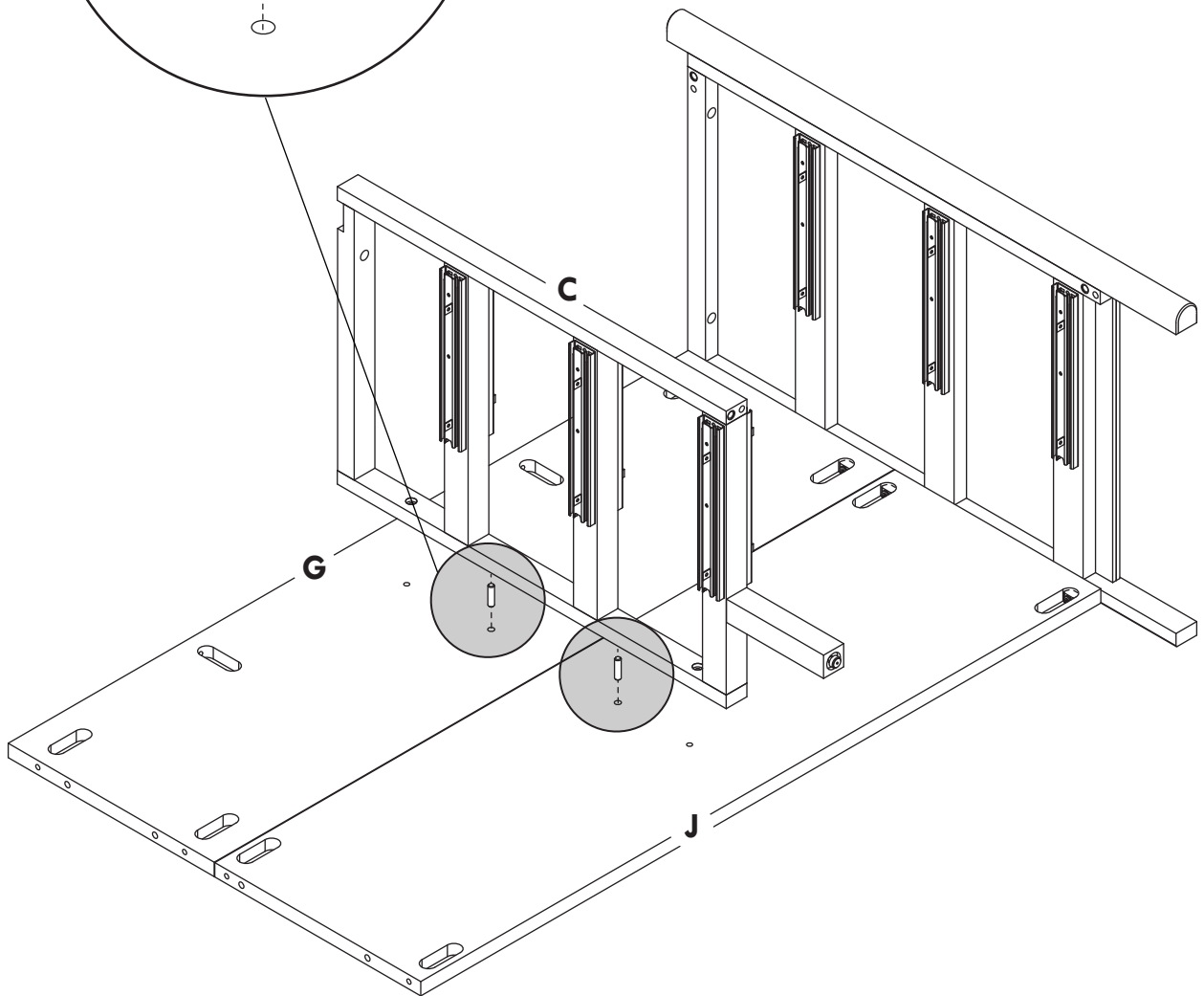

5

H2
X2

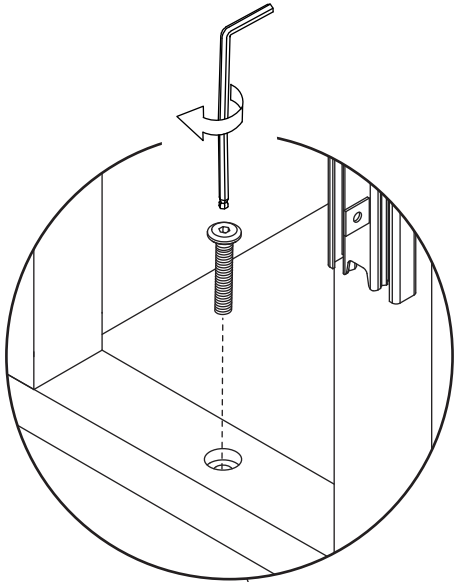
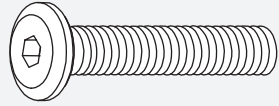

X2

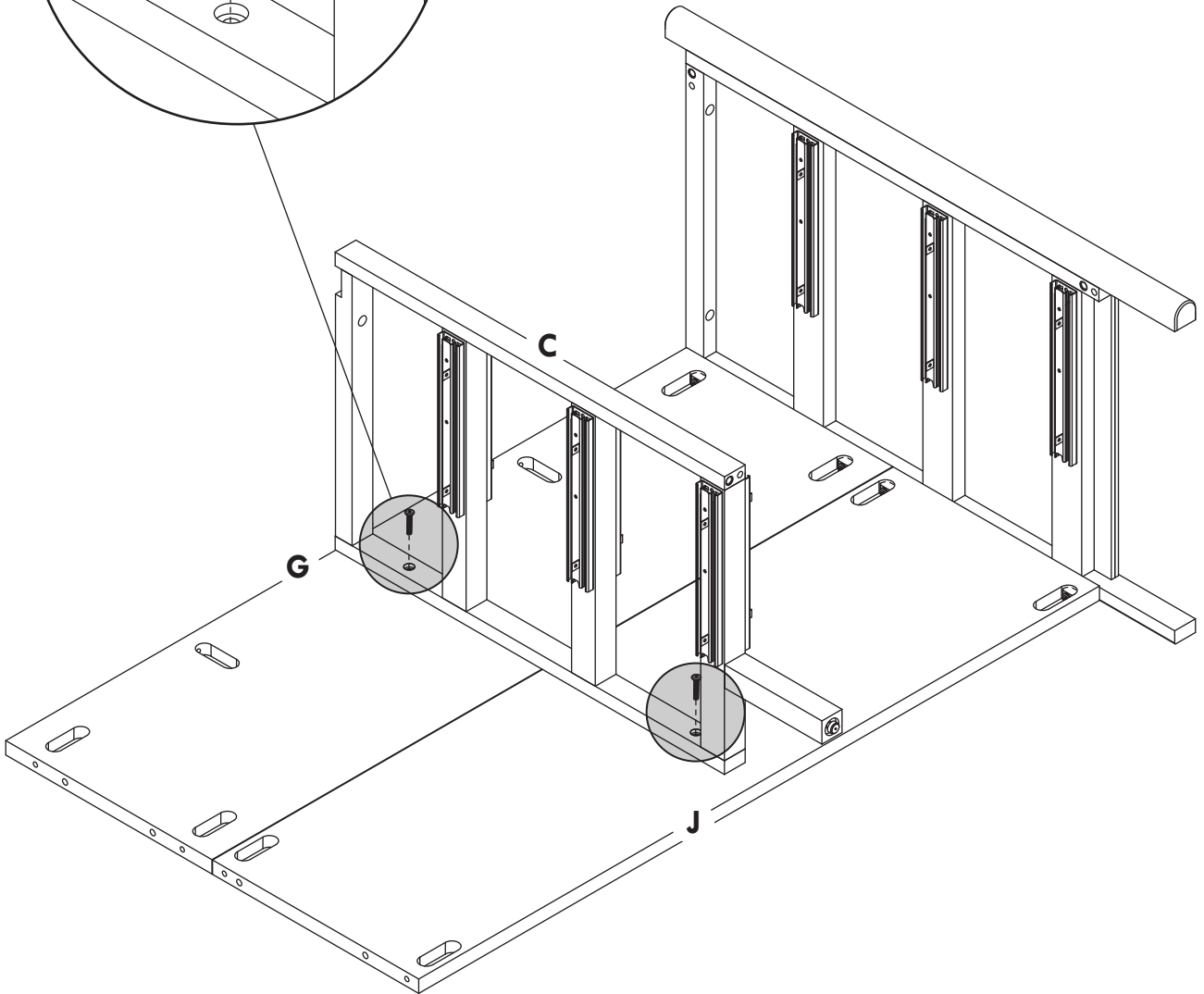

6

H6
X3

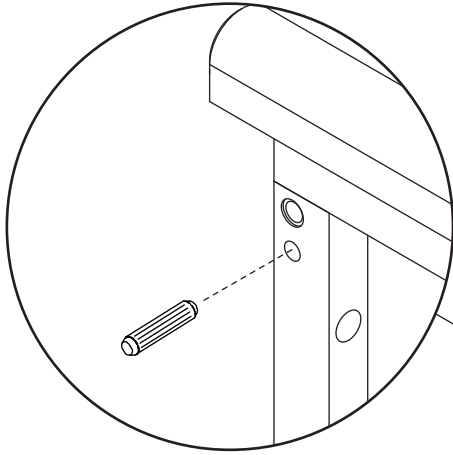

X3

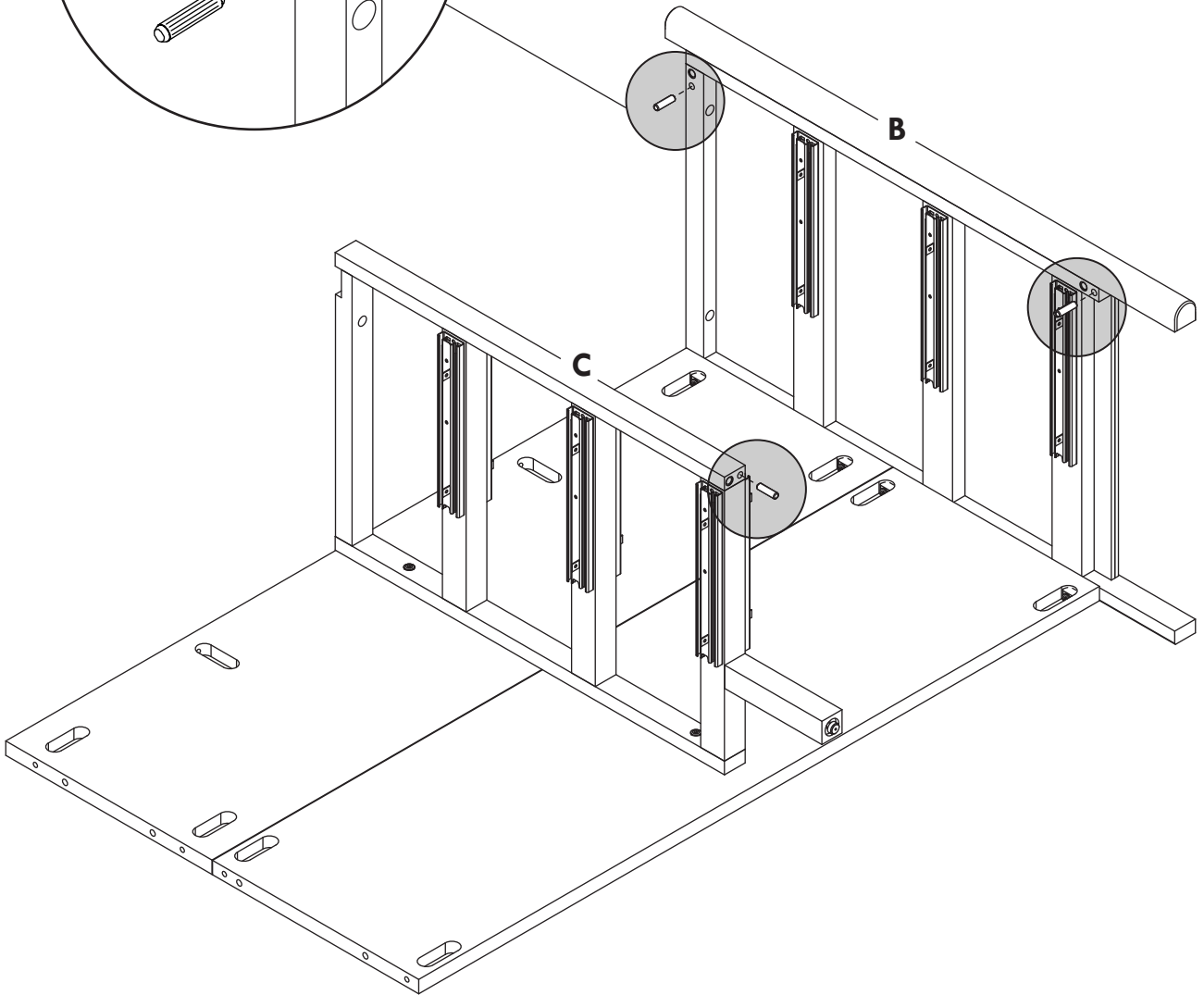

7

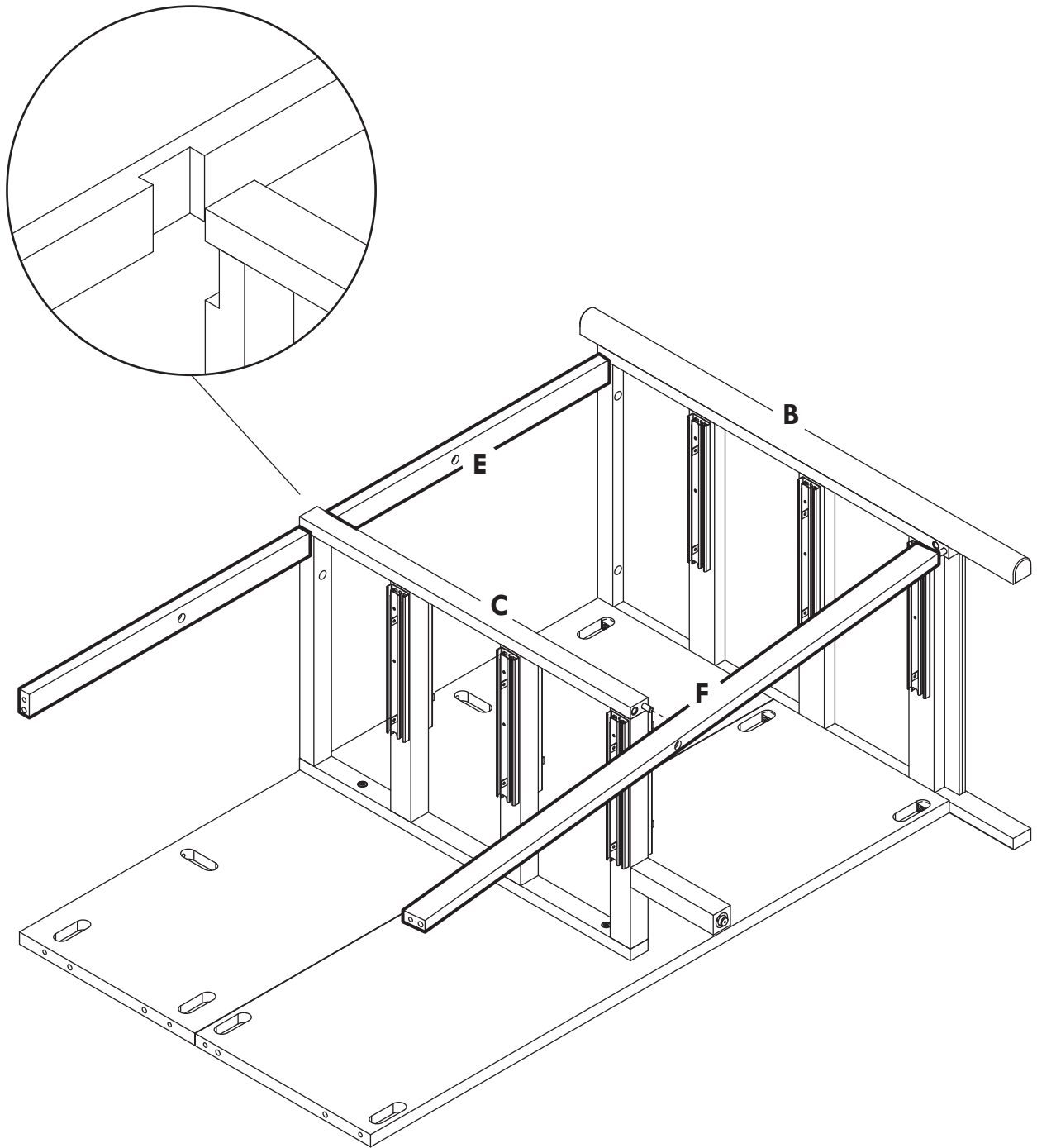

8

H1
X1

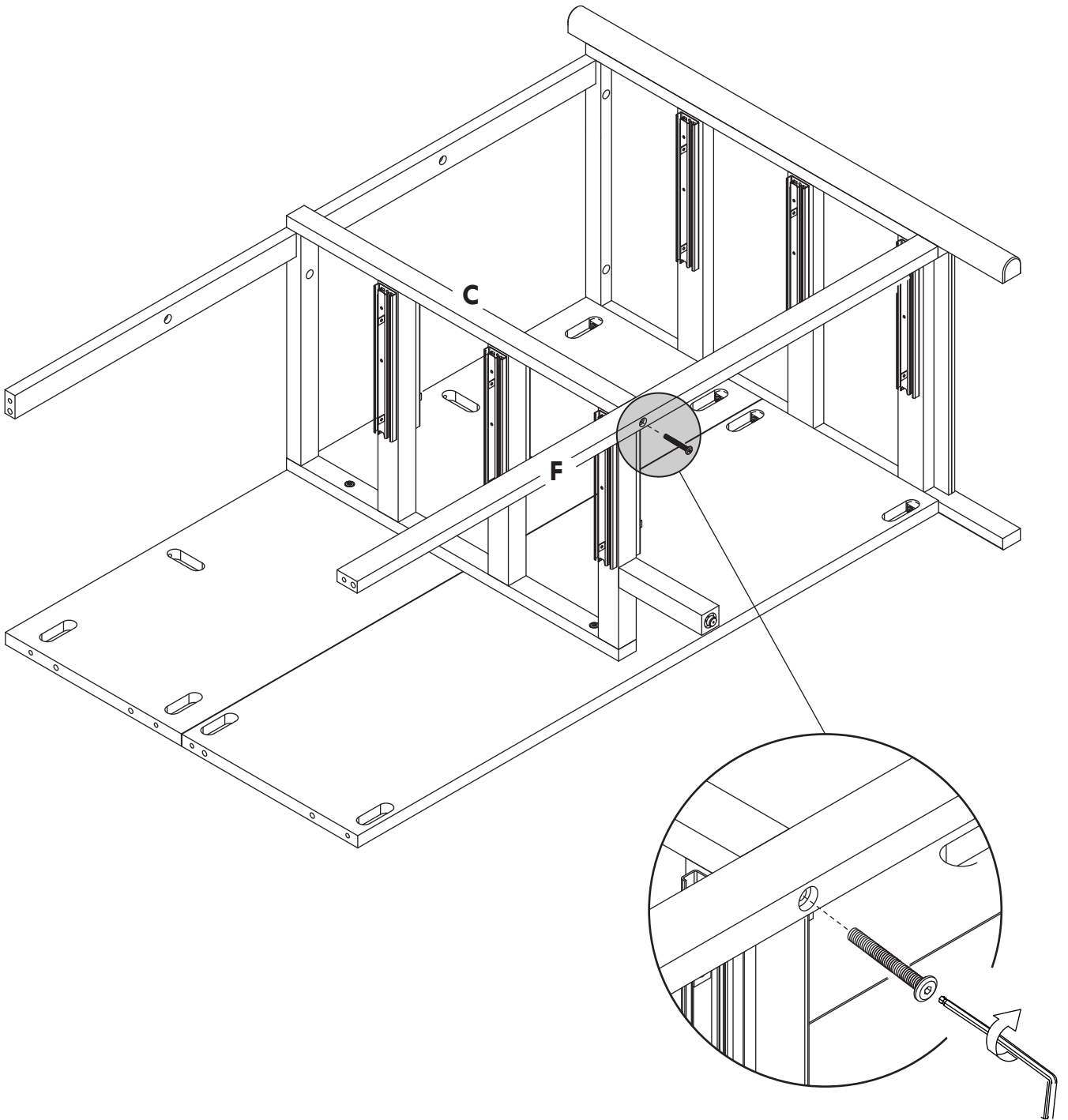
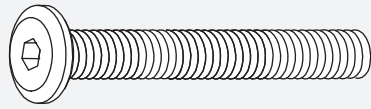

9

H1
X2

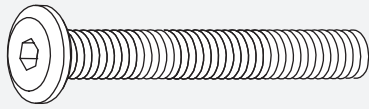

H8
X2

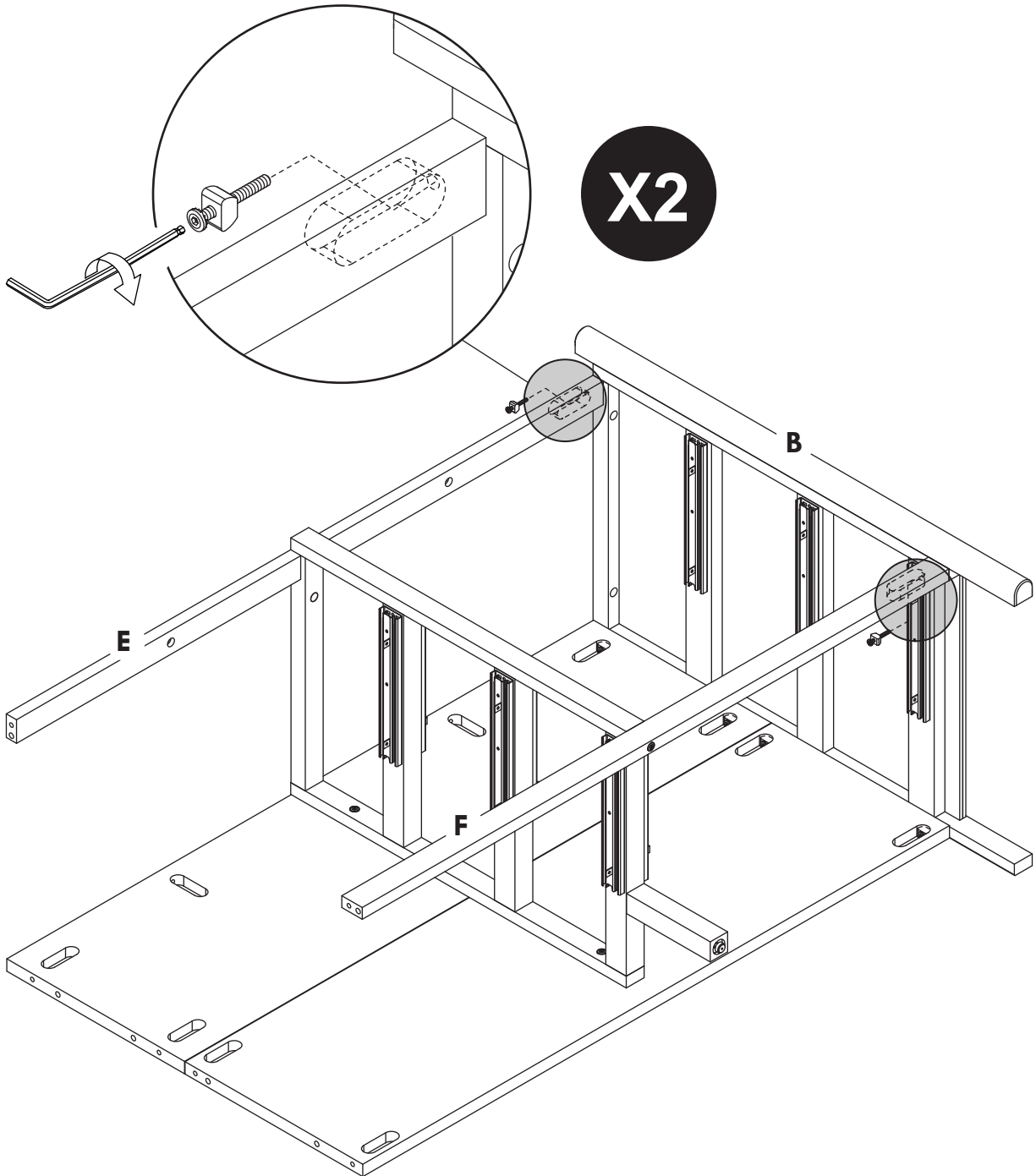
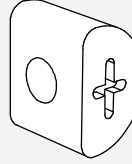

10

H6
X6

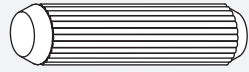

X6

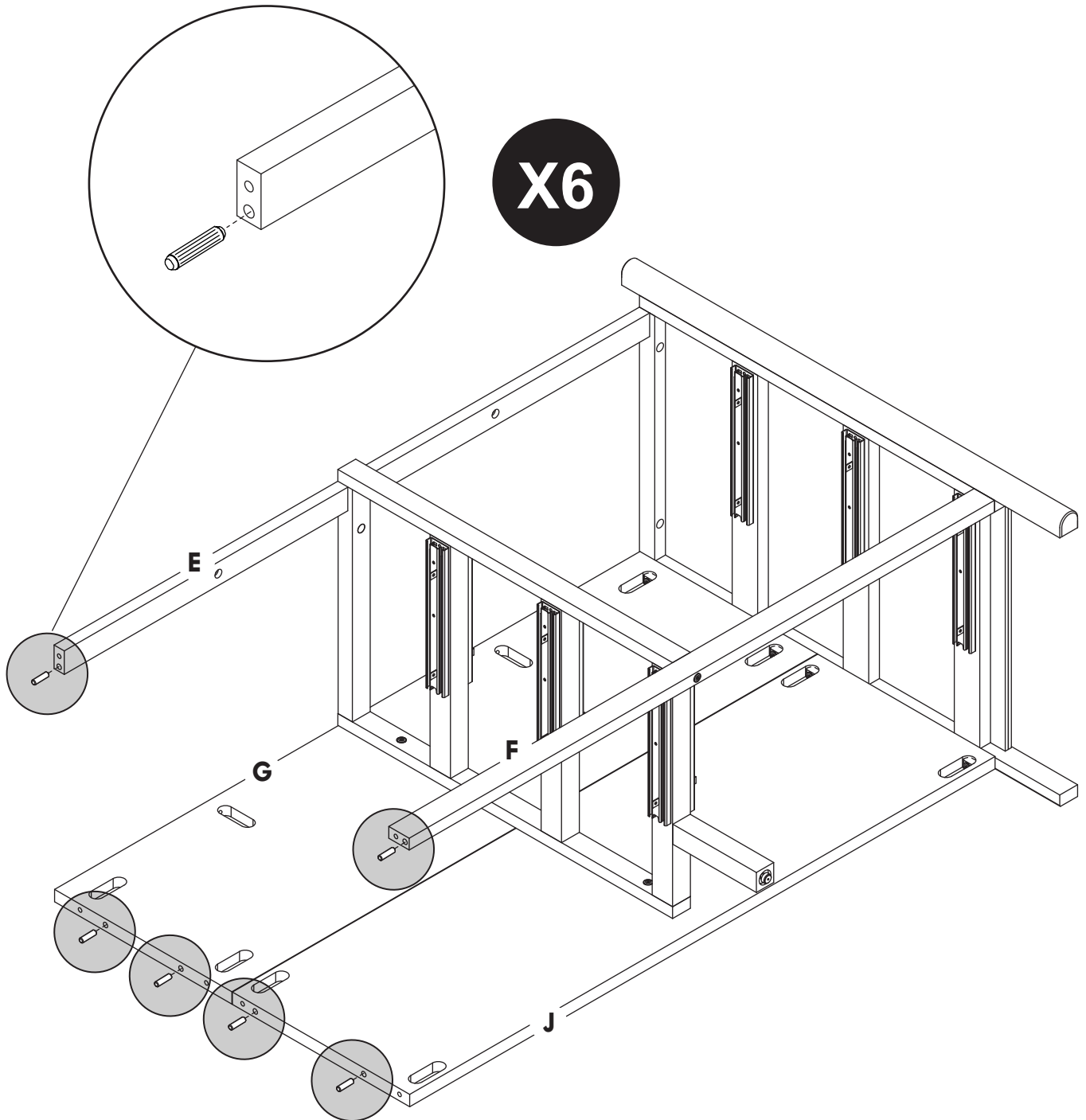

11

H1
X4

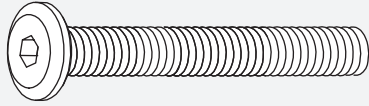

H8
X4

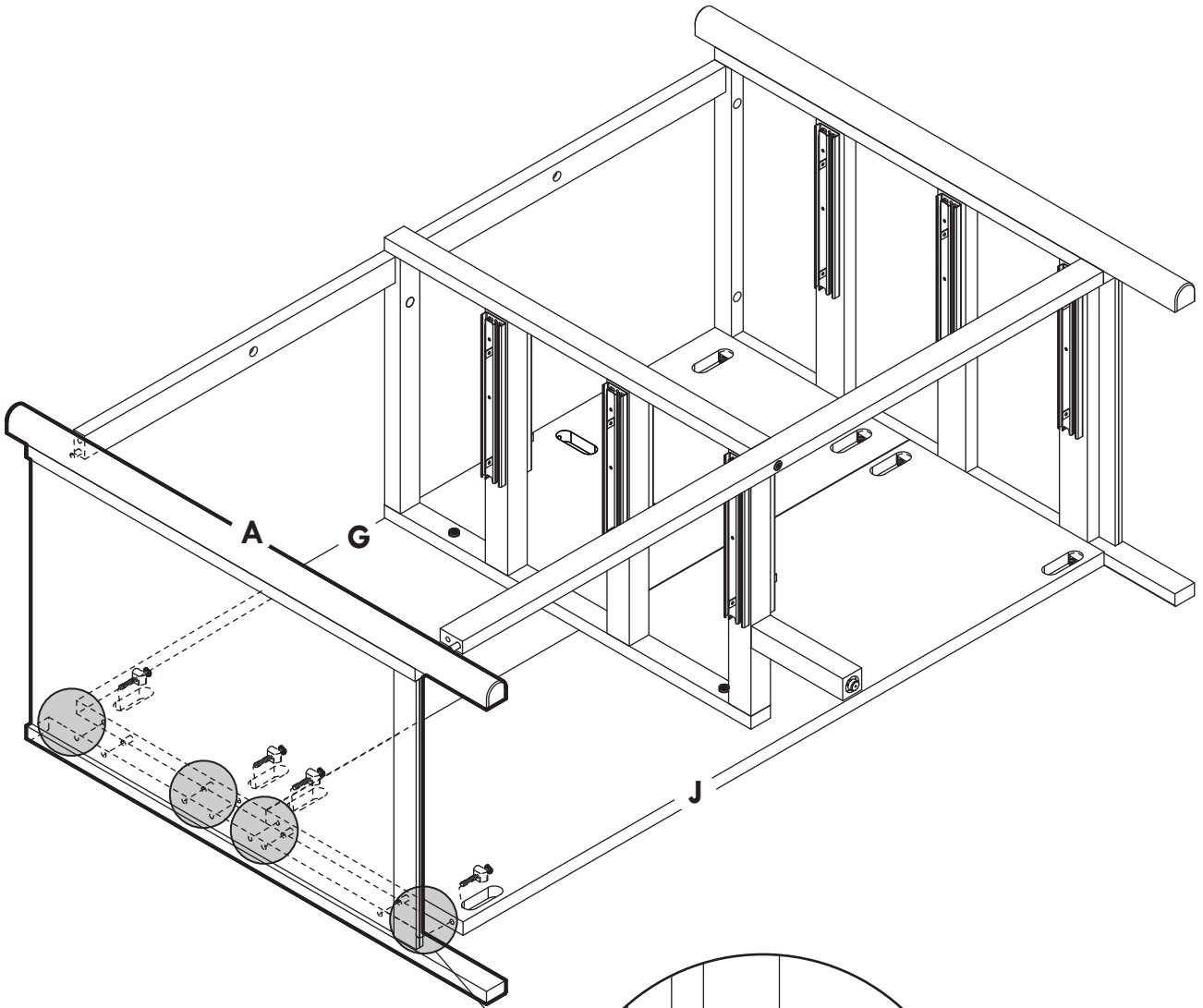
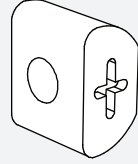

X4

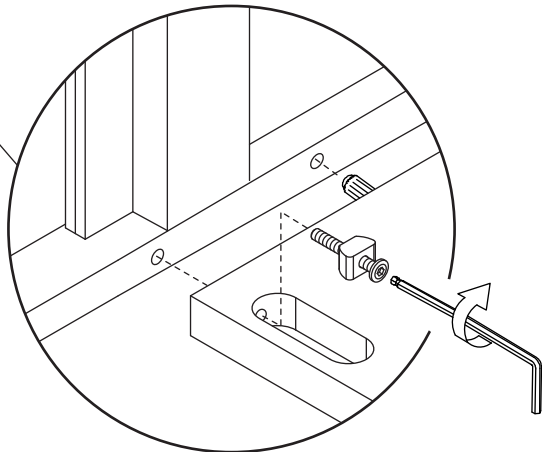

12

H1
X2

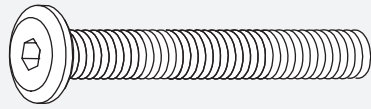

H8
X2

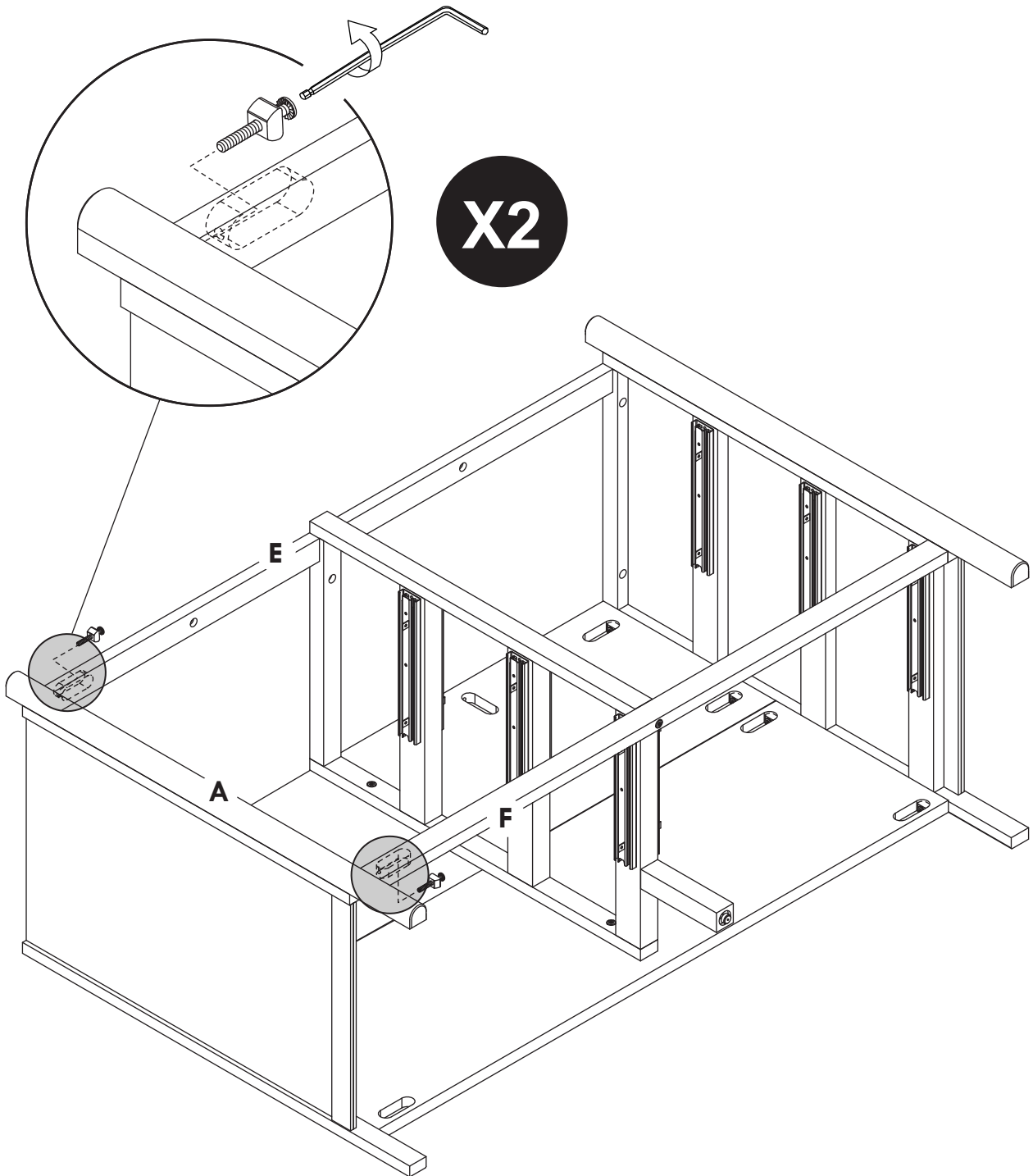
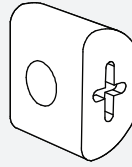

13

H6
X6

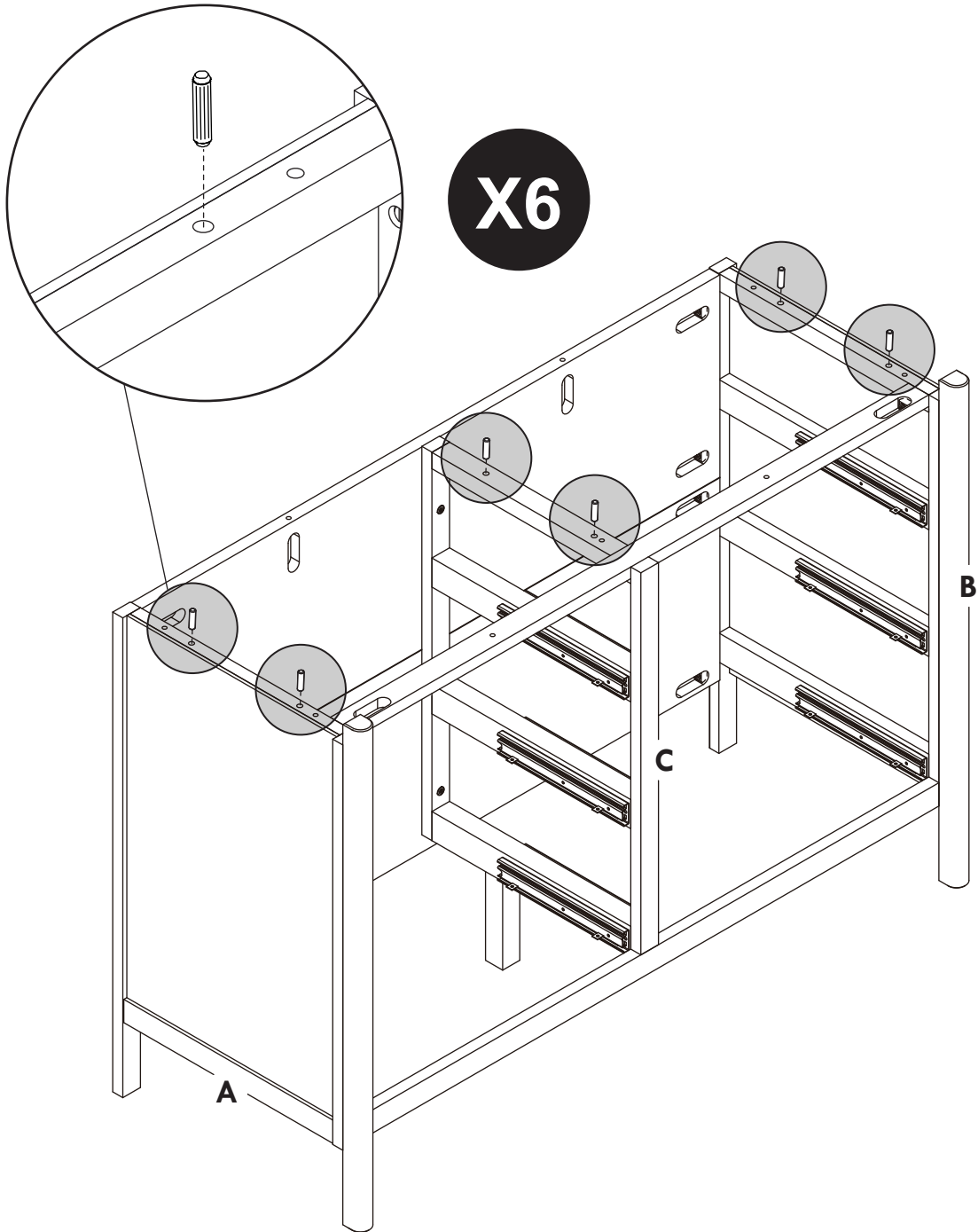
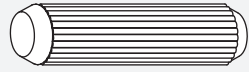

14

H2
X7

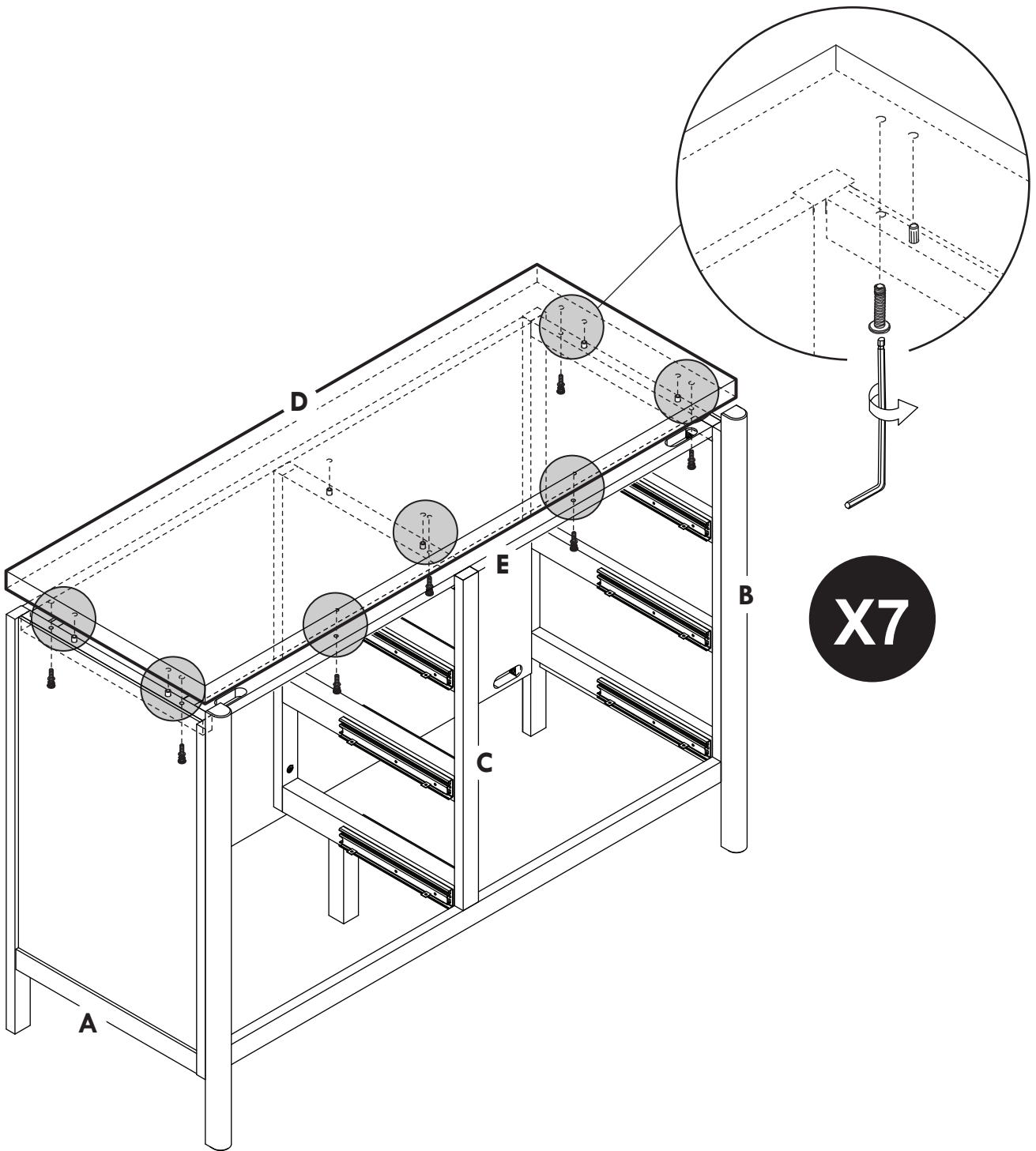
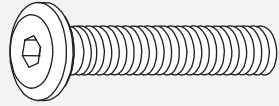

15

H1
X2

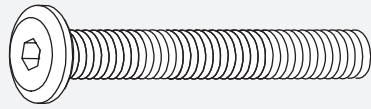

H8
X2

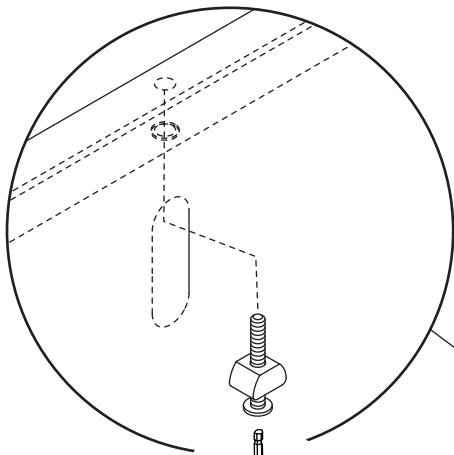
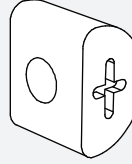

X2

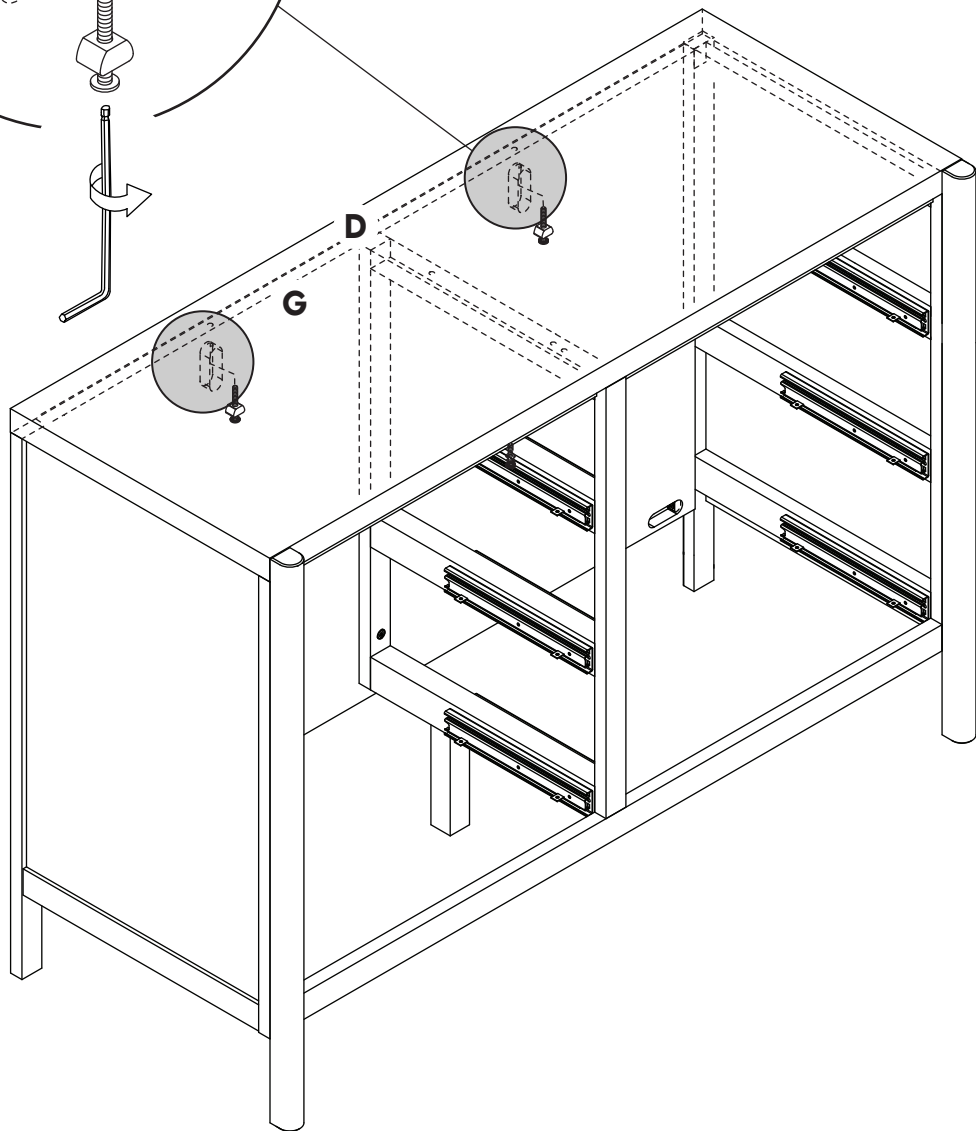

**ANTI-TIP KIT
INSTALLATION**

**INSTALACIÓN DEL KIT
CONTRA VOLCAMIENTOS**

**INSTALLATION DE LA
TROUSSE ANTI-BASCULEMENT**

16

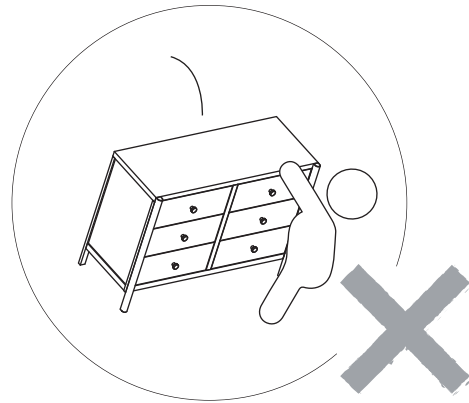
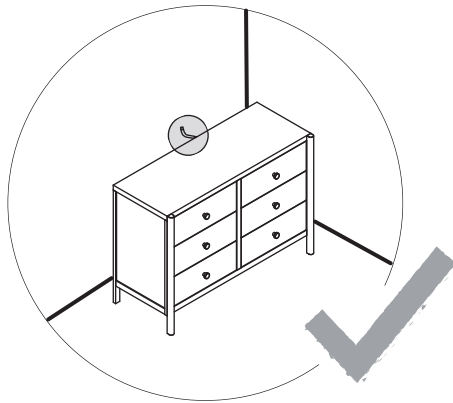

Children have died from furniture tipover. To reduce the risk of furniture tipover, ALWAYS install tip over restraint provided.

Han muerto niños al volcarse los muebles. Para reducir el riesgo de que se vuelque un mueble, SIEMPRE instale la sujeción contra volcamientos incluida.

Des enfants sont morts lors du basculement de meubles. Pour réduire le risque de basculement des meubles, veillez à TOUJOURS installer le dispositif de retenue fourni.

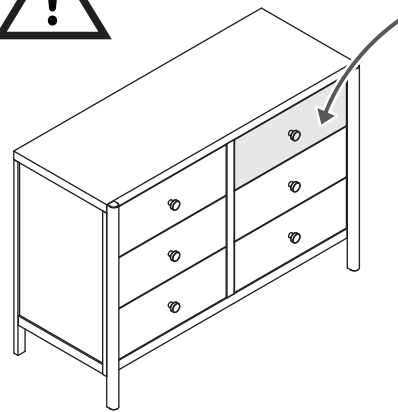

* Every detail of this dresser, including drawer extension, has been thoughtfully constructed in accordance with CPSC's ASTM F2507-23 standard to reduce tip-over risk.

* Cada detalle de esta cómoda, incluida la extensión del cajón, se ha construido cuidadosamente de acuerdo con la norma ASTM F2507-23 de la CPSC para reducir el riesgo de vuelco.

* Chaque détail de cette commode, y compris l'extension du tiroir, a été soigneusement construit selon la norme CPSC ASTM F2507-23 pour réduire le risque de renversement.

HARDWARE

actual size

HERRAJE

tamaño real

MATÉRIEL

taille actuelle



X2

For wall
Para la pared
Pour le mur



X2

For dresser
Para la cómoda
Pour la commode

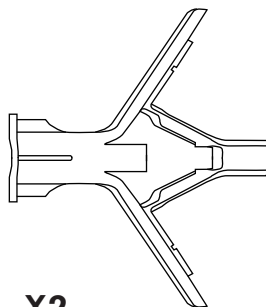

X2

For drywall
Para tablaroca
Pour une cloison en plâtre

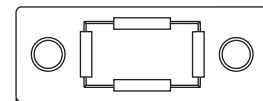

X2

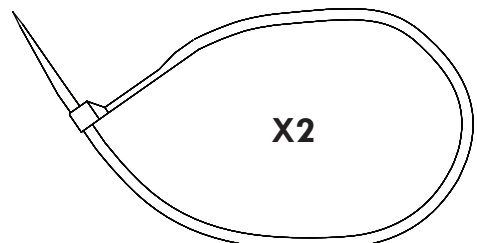

X2

EN

Find your wall material and follow steps to attach the anti-tip kit to your wall.

Drywall or plaster with available wood stud:

- Holding the bracket 1" to 2" (25-50 mm) below top of dresser, mark the attachment holes with a pencil.
- Drill 1/8-inch (3 mm) diameter pilot holes into the wood stud, on the pencil marks.
- Following the appropriate pictogram instructions on the following pages, drive two screws through the bracket and tighten screws firmly into the wood.

Drywall without available wood stud:

- Holding the bracket 1" to 2" (25-50 mm) below top of dresser, mark the attachment holes with a pencil.
- Drill 3/8-inch (9 mm) diameter holes through the wall, on the pencil marks.
- Drive the plastic anchors into the holes, using a hammer if needed.
- Following the appropriate pictogram instructions on the following pages, drive two screws through the bracket and tighten screws firmly into the plastic anchors in the wall. Do not over-tighten.

If your wall material is not listed here, or if you have any questions, consult your local hardware store.

ES

Determine el material de la pared y siga los pasos para instalar el kit anti-volcamientos en la pared.

Tablaroca o panel de yeso con remache de madera disponible:

- Sosteniendo el soporte a 25-50 mm (1-2 pulgadas) bajo la parte superior de la cómoda, marque los agujeros de la instalación con un lápiz.
- Taladre agujeros guía de 3 mm (1/8 pulgada) de diámetro en los remaches de madera, en las marcas hechas con el lápiz.
- Siguiendo las instrucciones correspondientes del pictograma en las páginas siguientes, instale dos tornillos a través de el soporte y apriete los tornillos firmemente en la madera.

Tablaroca sin remache de madera disponible:

- Sosteniendo el soporte a 25-50 mm (1-2 pulgadas) bajo la parte superior de la cómoda, marque los agujeros de la instalación con un lápiz.
- Taladre agujeros de 9 mm (3/8 pulgada) de diámetro en la pared, sobre las marcas hechas con el lápiz.
- Instale las fijaciones de plástico en los agujeros, usando un martillo si es necesario.
- Siguiendo las instrucciones correspondientes del pictograma en las páginas siguientes, instale dos tornillos a través de el soporte y apriete los tornillos firmemente en la pared. No apriete en exceso.

Si no aparece indicado aquí el material de la pared, o si tiene alguna pregunta, consulte con su ferretería local.

FR

Trouvez votre propre matériau mural et suivez les étapes pour fixer la trousse anti-basculement à votre mur.

Cloison sèche et en plâtre avec montants en bois:

- En tenant le support à une distance de 25 à 50 mm (1 à 2 po) sous le dessus de la commode, marquez les trous de fixation à l'aide d'un crayon.
- Percez des avant-trous d'un diamètre de 3 mm (1/8 po) dans le montant en bois, sur les marques de crayon.
- Suivez les instructions sous forme de pictogramme figurant sur les pages suivantes, insérez deux vis dans le support, puis vissez fermement dans le montant en bois.

Cloison sèche sans montant en bois :

- En tenant le support à une distance de 25 à 50 mm (1 à 2 po) sous le dessus de la commode, marquez les trous de fixation à l'aide d'un crayon.
- Percez un avant-trou d'un diamètre de 9 mm (3/8 po) dans le montant en bois, sur les marques de crayon.
- Insérez les ancrages en plastique dans les trous, à l'aide d'un marteau au besoin.
- Suivez les instructions sous forme de pictogramme figurant sur les pages suivantes, insérez deux vis dans le support et serrez les vis fermement dans les ancrages en plastique dans le mur. Ne serrez pas excessivement.

Si le matériau de votre mur ne figure pas dans la liste ci-dessus, ou si vous avez des questions, adressez-vous à votre fournisseur local.

16a

Fasten bracket to back of dresser.

Fije el soporte en la parte posterior de la cómoda.

Fixez le support à l'arrière de la commode.

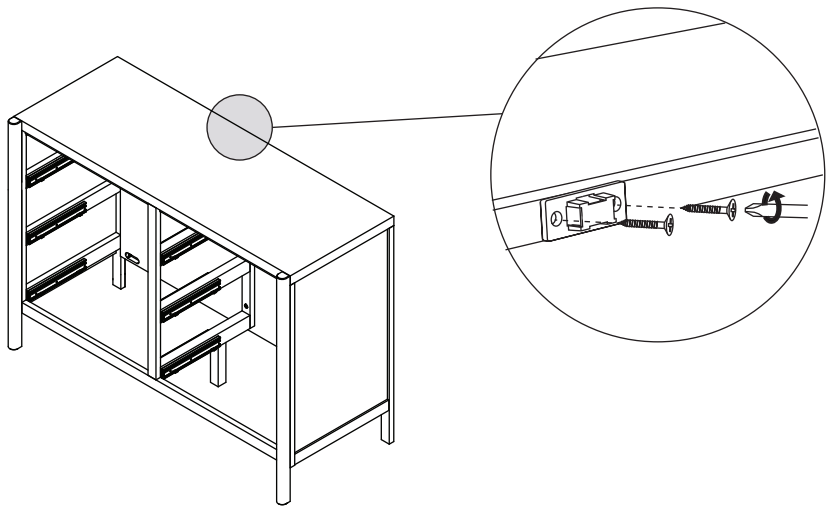

16b

Place second bracket on the wall 1-2" (25-50mm) below the top of the dresser and mark holes.

Ponga el segundo soporte en la pared a 25-50 mm (1-2 pulgadas) debajo de la parte superior de la cómoda y marque los agujeros.

Placez un deuxième support sur le mur à une distance de 25 à 50 mm (1 à 2 po) sous le dessus de la commode et marquez les trous.

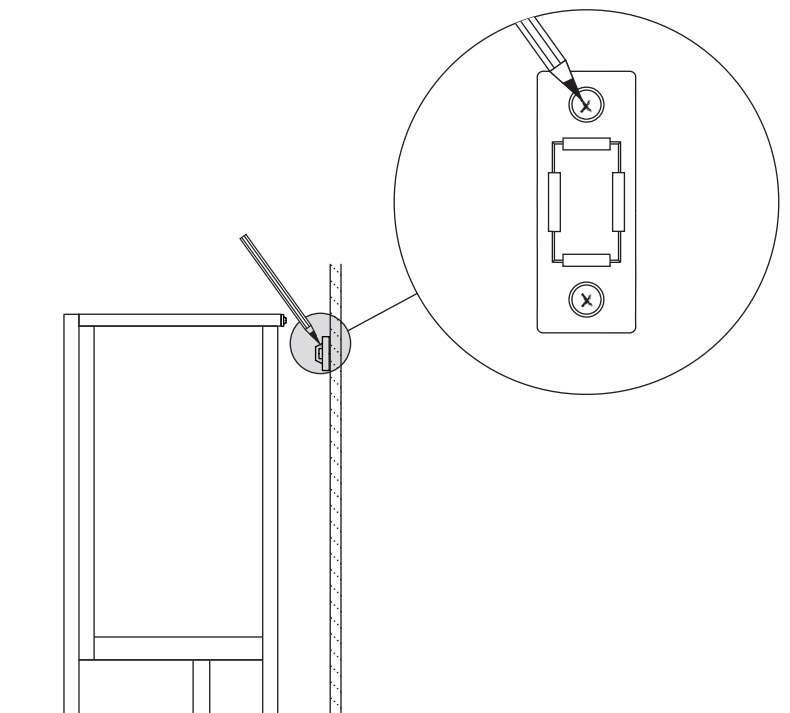

16c

Follow the "Find Your Wall Material" instructions on the previous page.

Drill a 3/8" (9 mm) hole and insert plastic anchor into hole (if needed).

Siga las "Instrucciones según el tipo de material de la pared" en la página anterior.

Taladre un agujero de 9 mm (3/8 pulgada) e inserte la fijación de plástico en el agujero (si es necesario).

Trouvez votre matériau mural et suivez les instructions portant sur le « Type de matériau du mur » de la page ci-dessus. Percez un trou de 9 mm (3/8 po) et insérez l'ancrage en plastique dans le trou (au besoin).

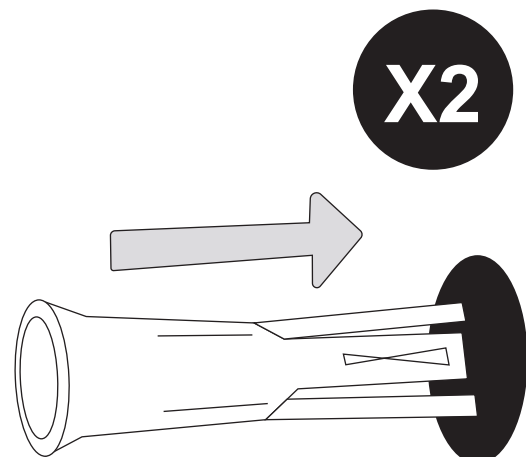

16d

Fasten second bracket by screwing into plastic anchors or wood stud.

Fije el segundo soporte atornillando en las fijaciones de plástico o el remache de madera.

Fixez le deuxième support en vissant dans les ancrages en plastique ou le montant en bois.

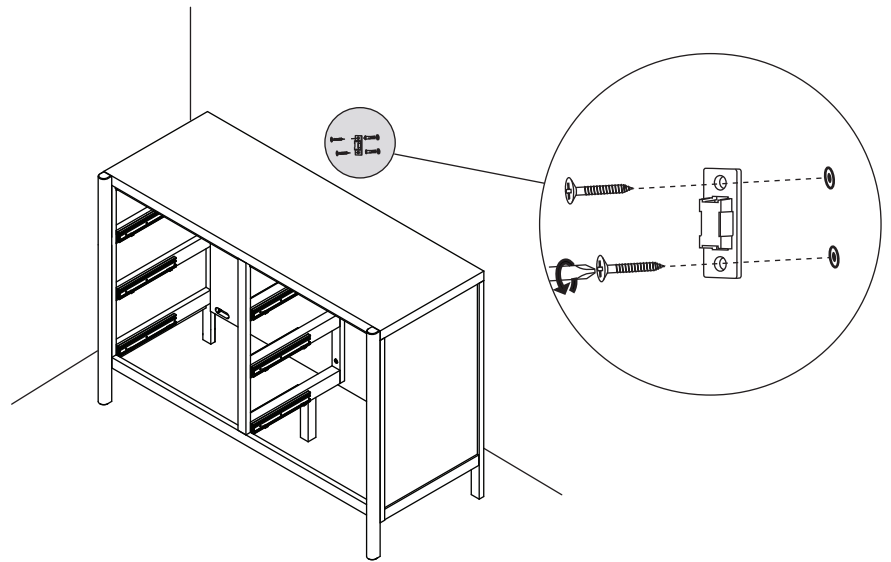

16e

Loop provided 2 ties through both brackets and secure tightly.

Pase los amarra provista a través de ambos soportes y asegure firmemente.

Passez les attachés fournie dans les deux supports et fixez solidement.

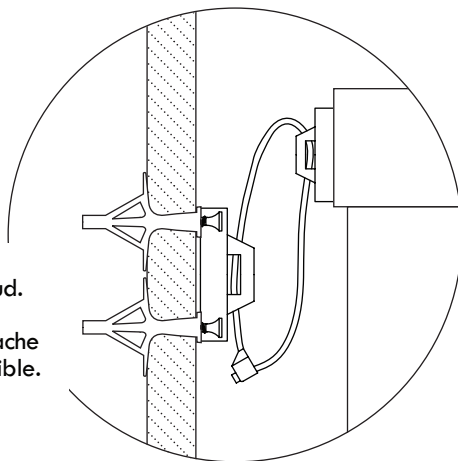

* Drywall without available wood stud.

* Tablaroca sin remache de madera disponible.

* Cloison sèche sans montant en bois.

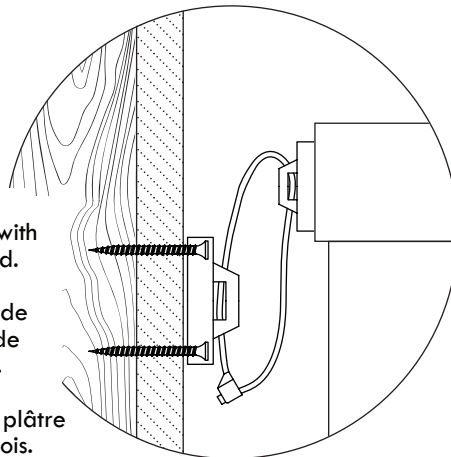

* Drywall or plaster with available wood stud.

* Tablaroca o panel de yeso con remache de madera disponible.

* Cloison sèche et en plâtre avec montants en bois.

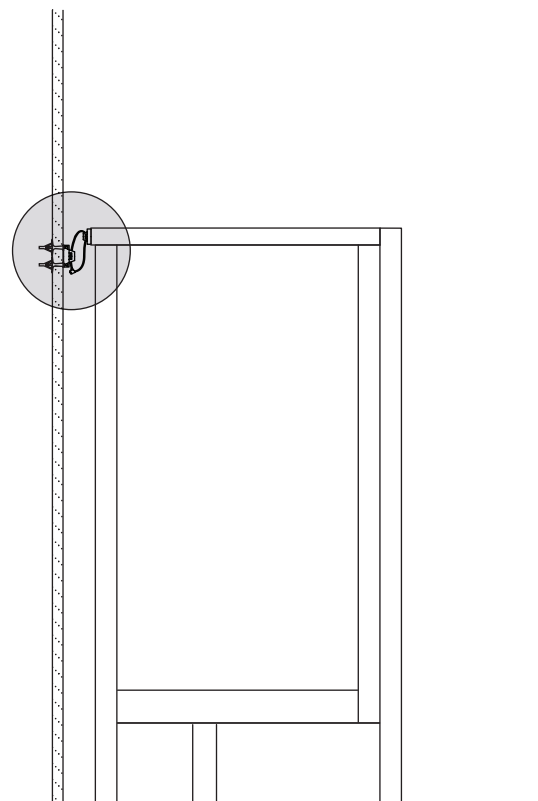

17a

H3
X4

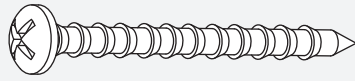

H7
X2

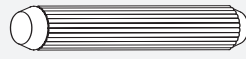

H9
X4

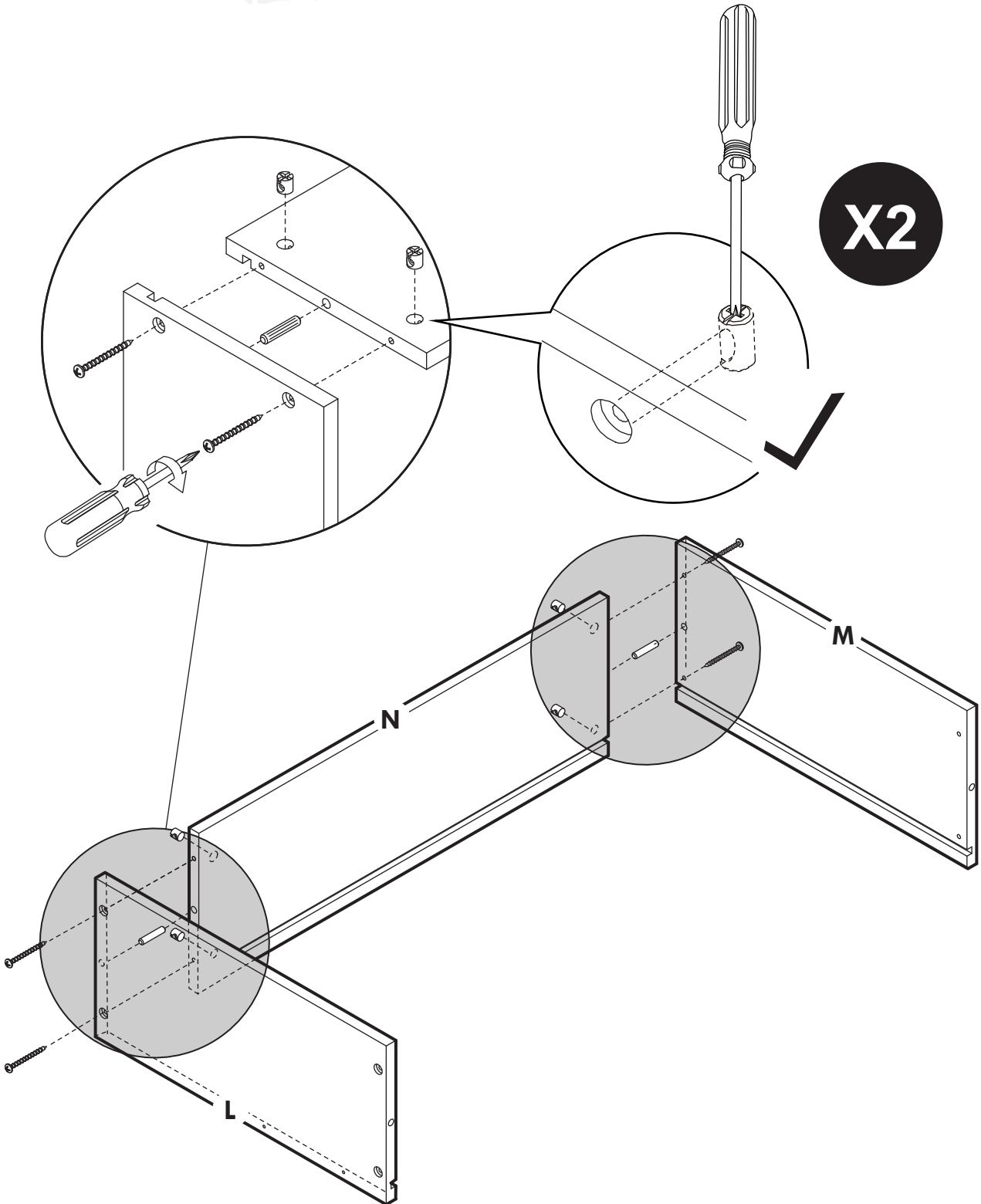

17b

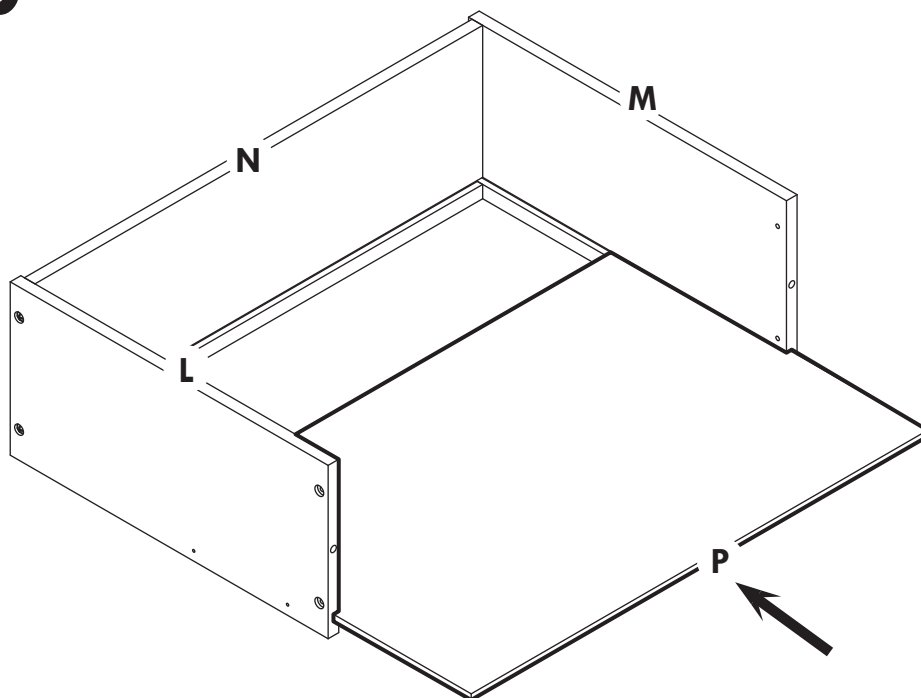

17c

H7
X2

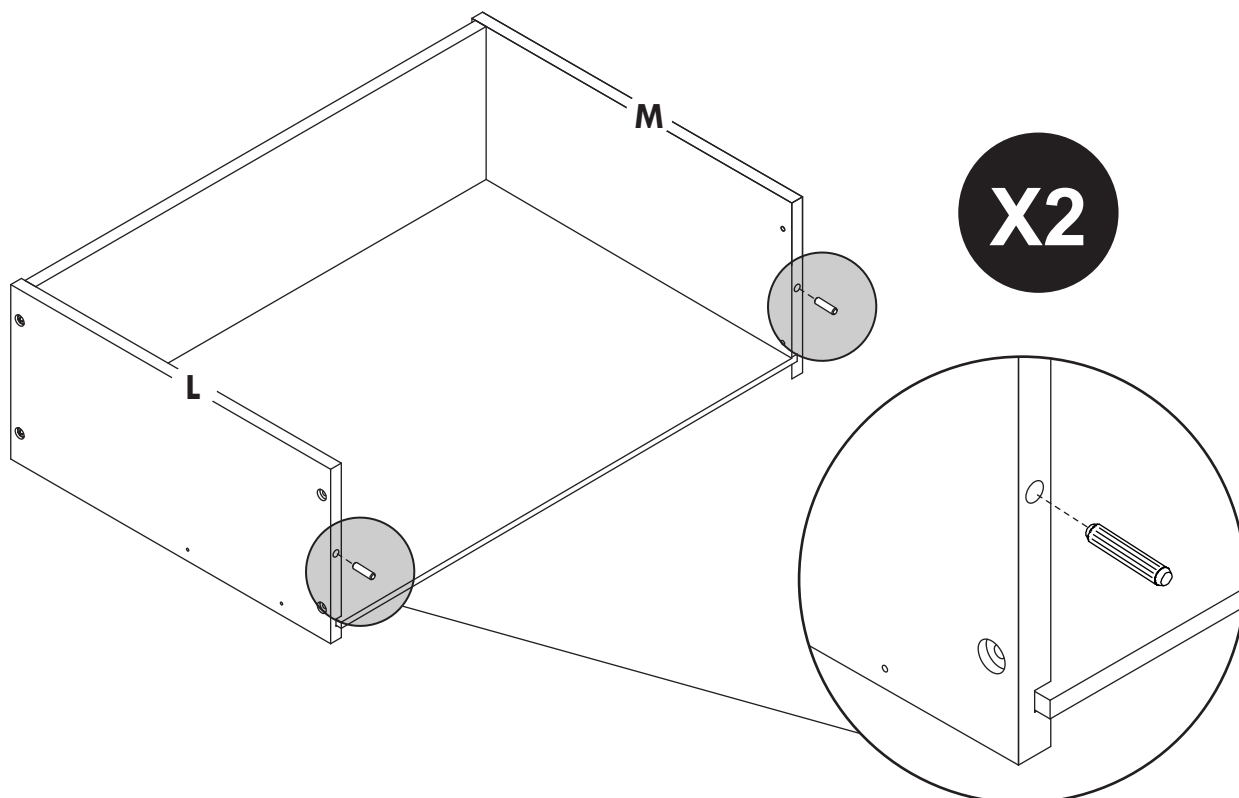

17d

H4
X4

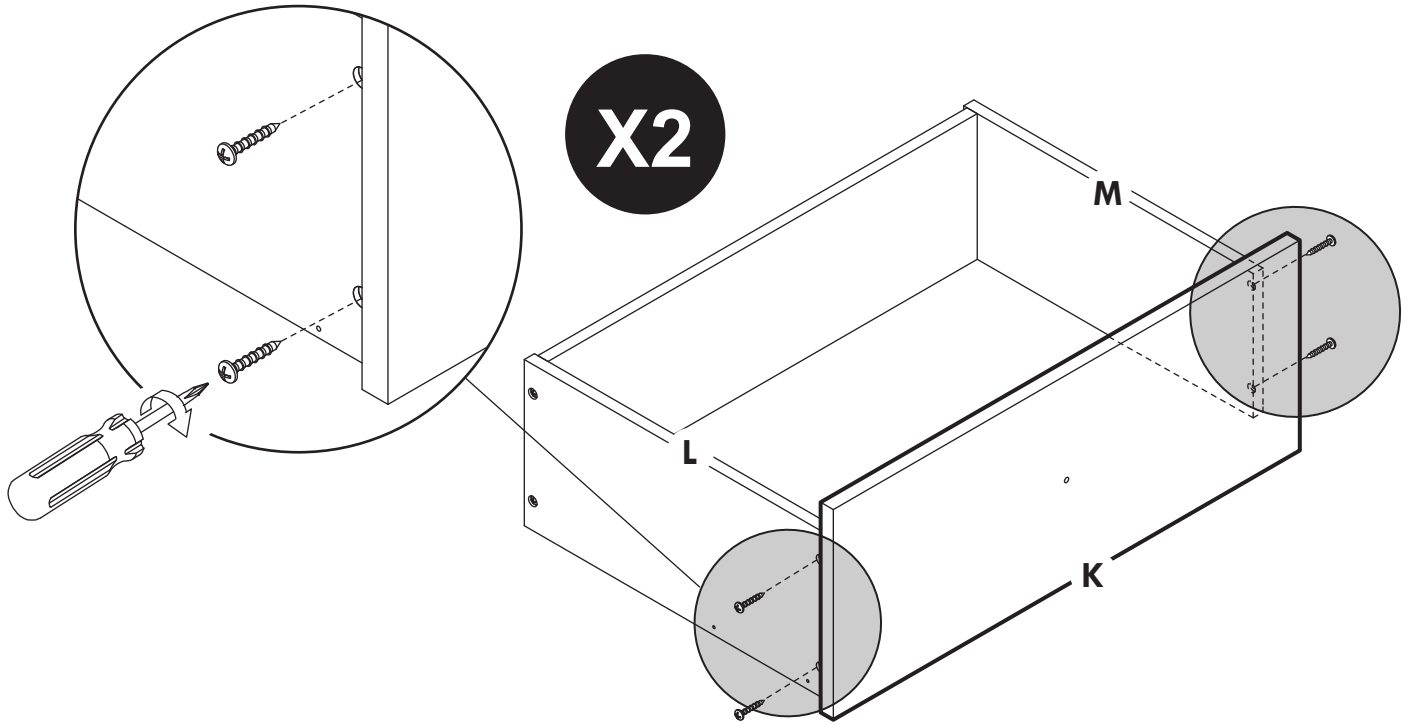
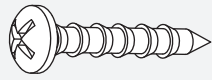

17e

H10
X1



H11
X1

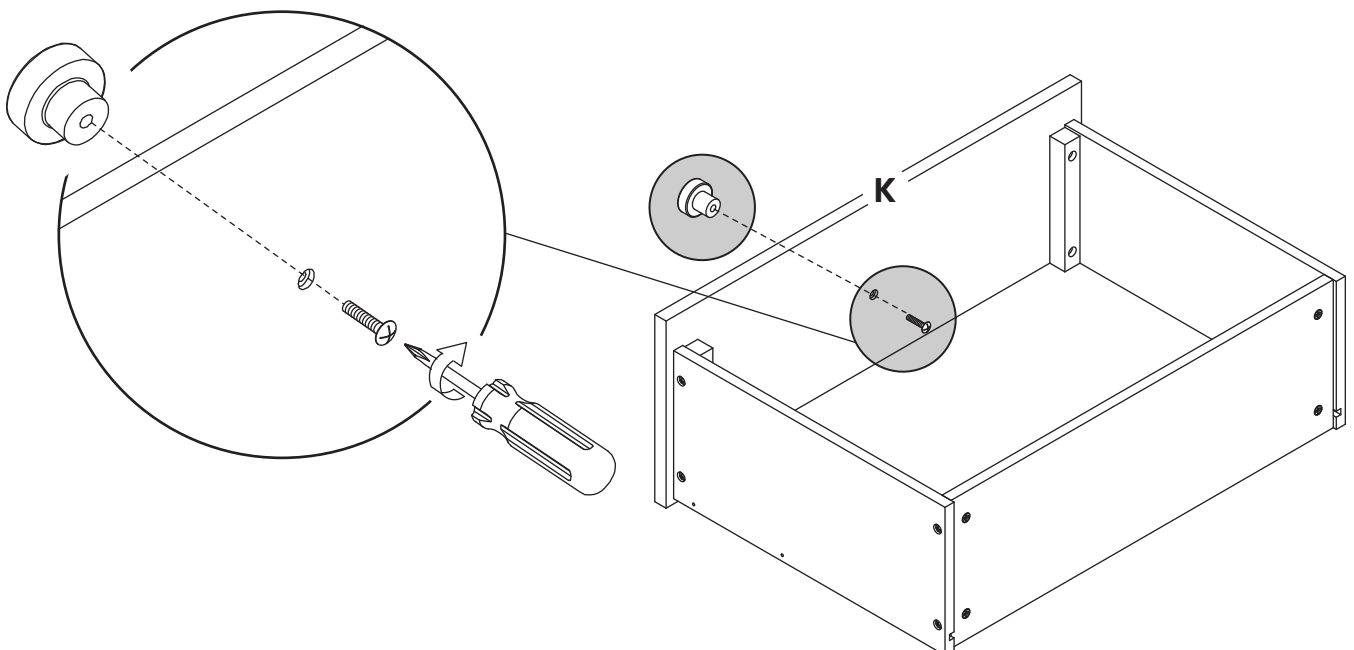
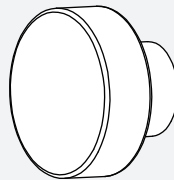

17f

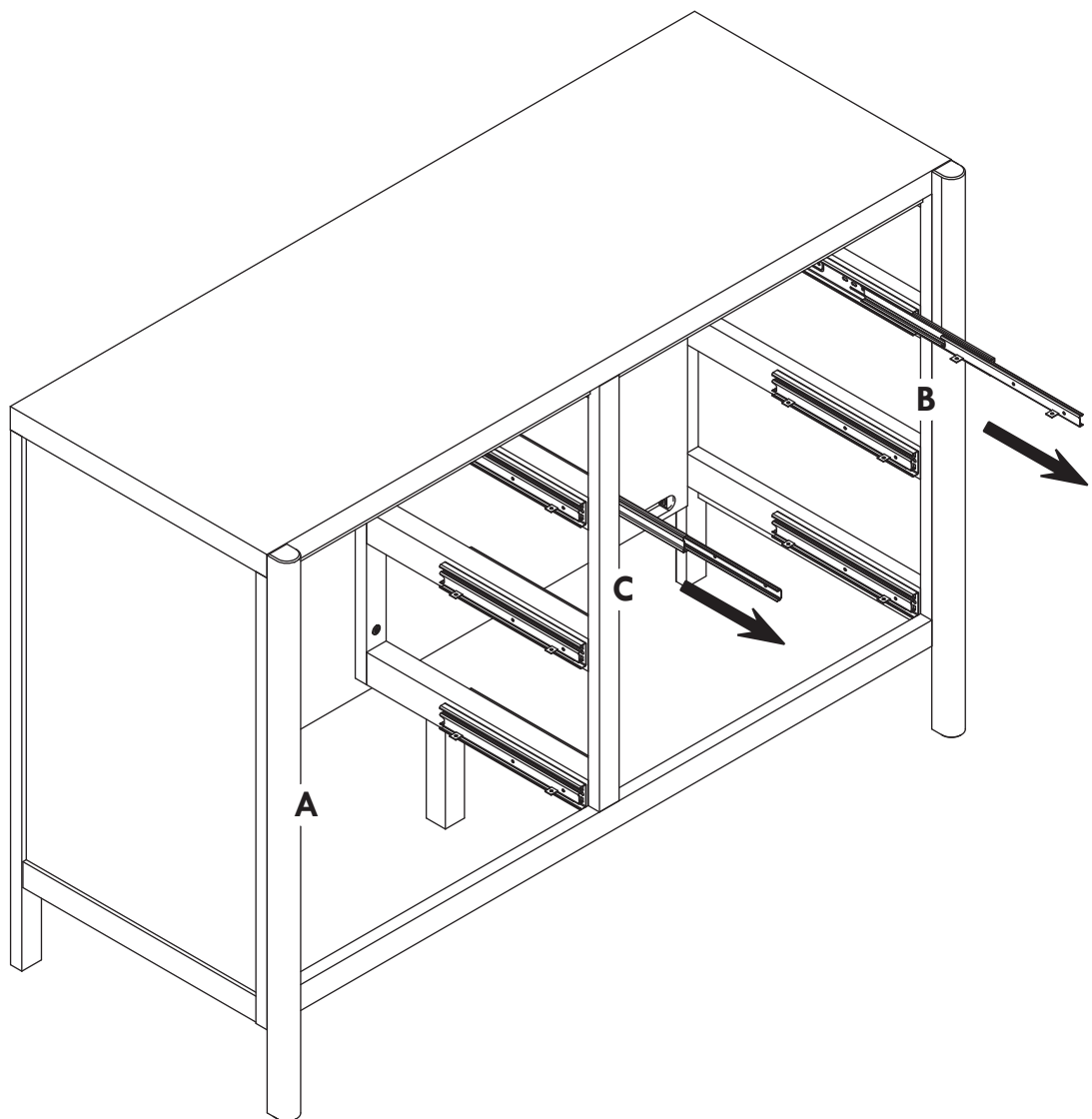

17g

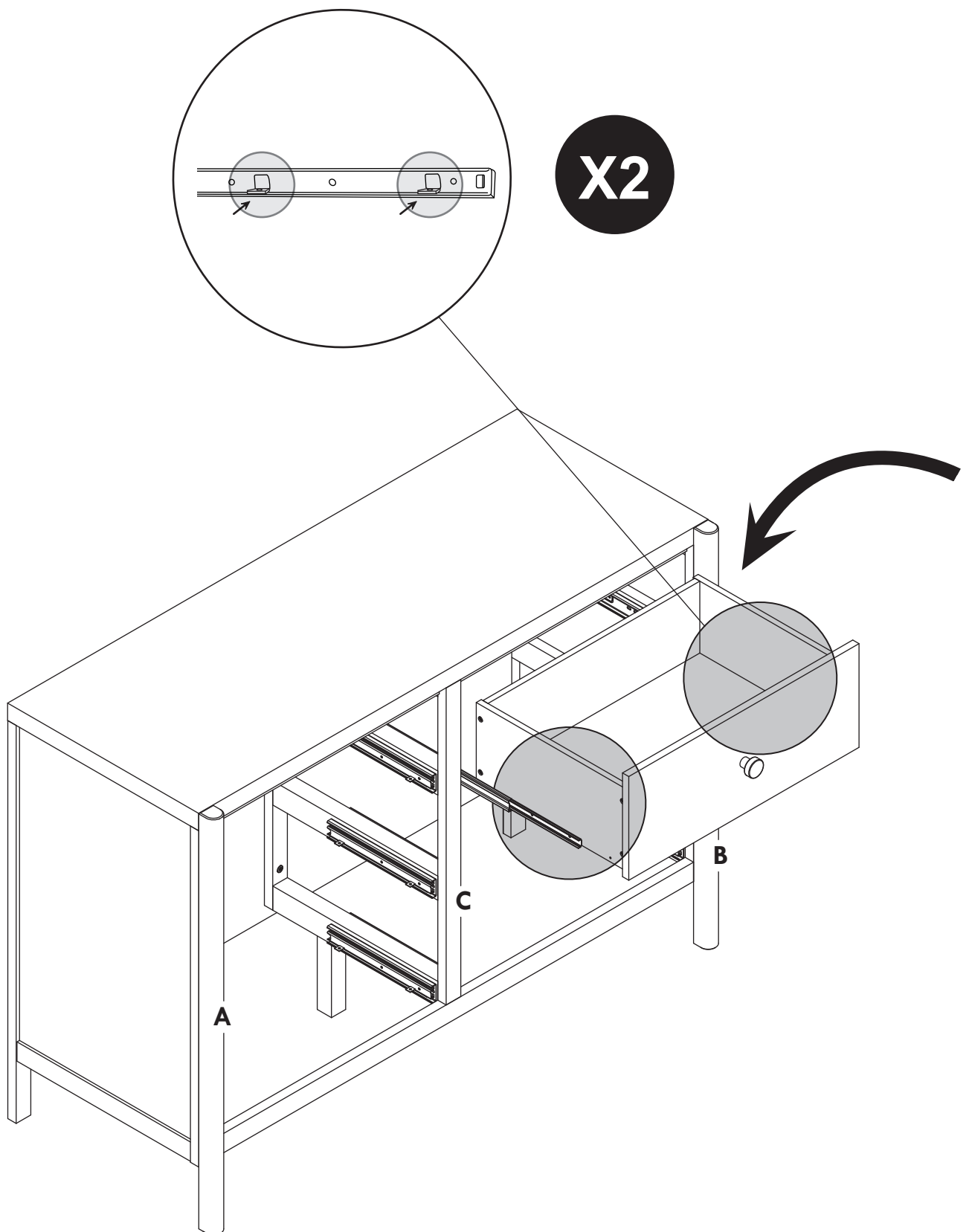

17h

H5
X4

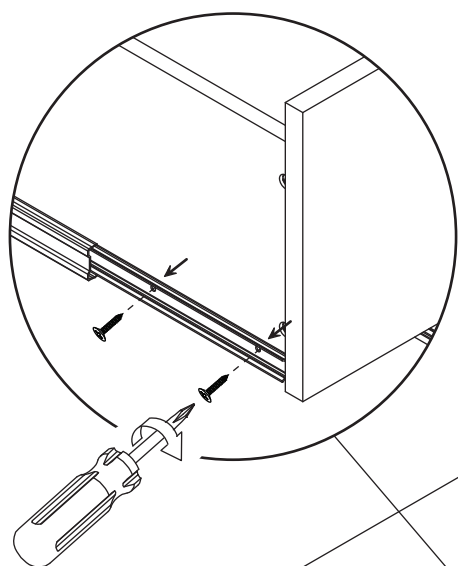

X2

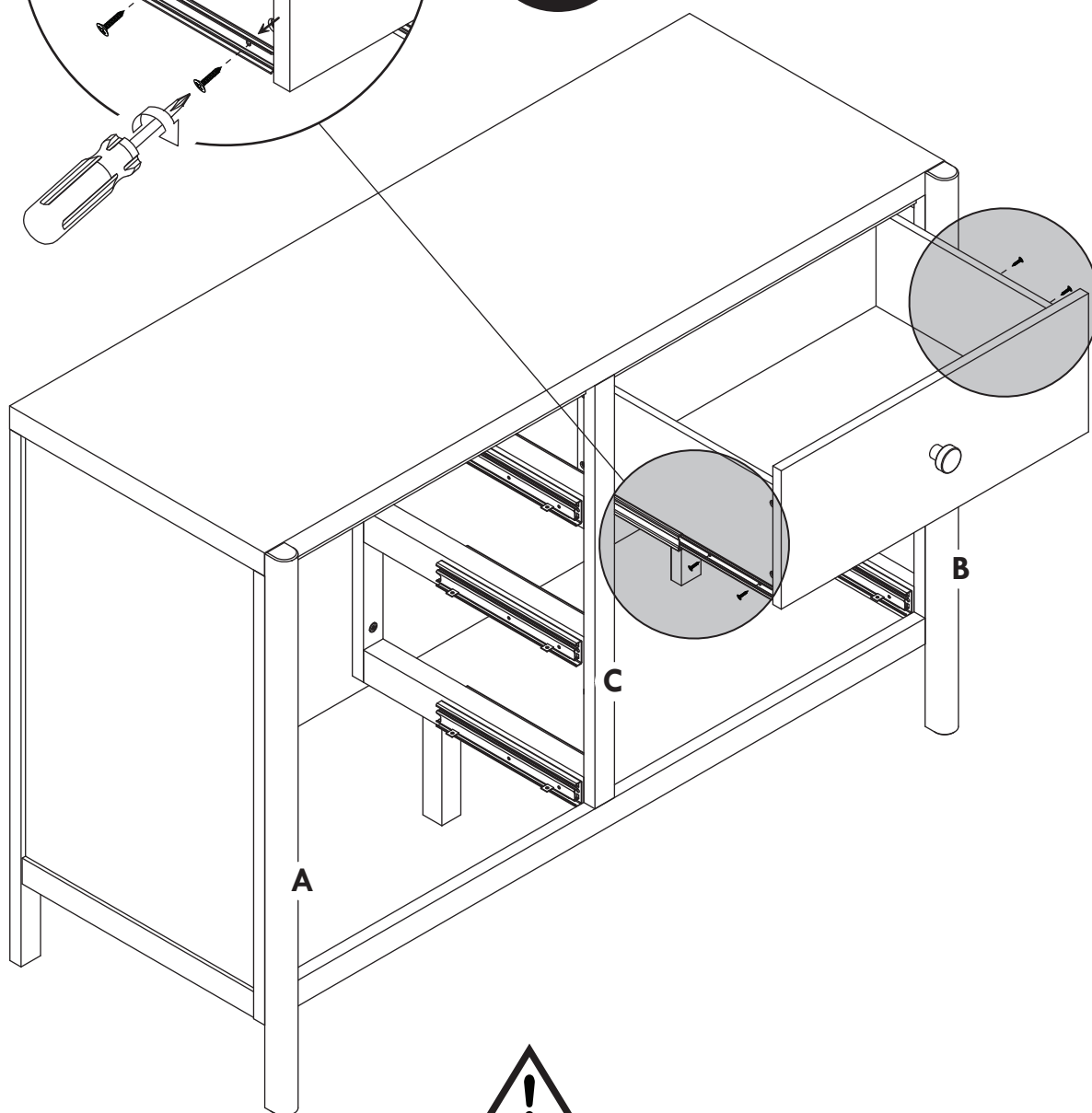

DO NOT OVERTIGHTEN THE SCREWS.

NO APRIETE LOS TORNILLOS EN EXCESO.

NE SERREZ PAS TROP LES VIS.

18

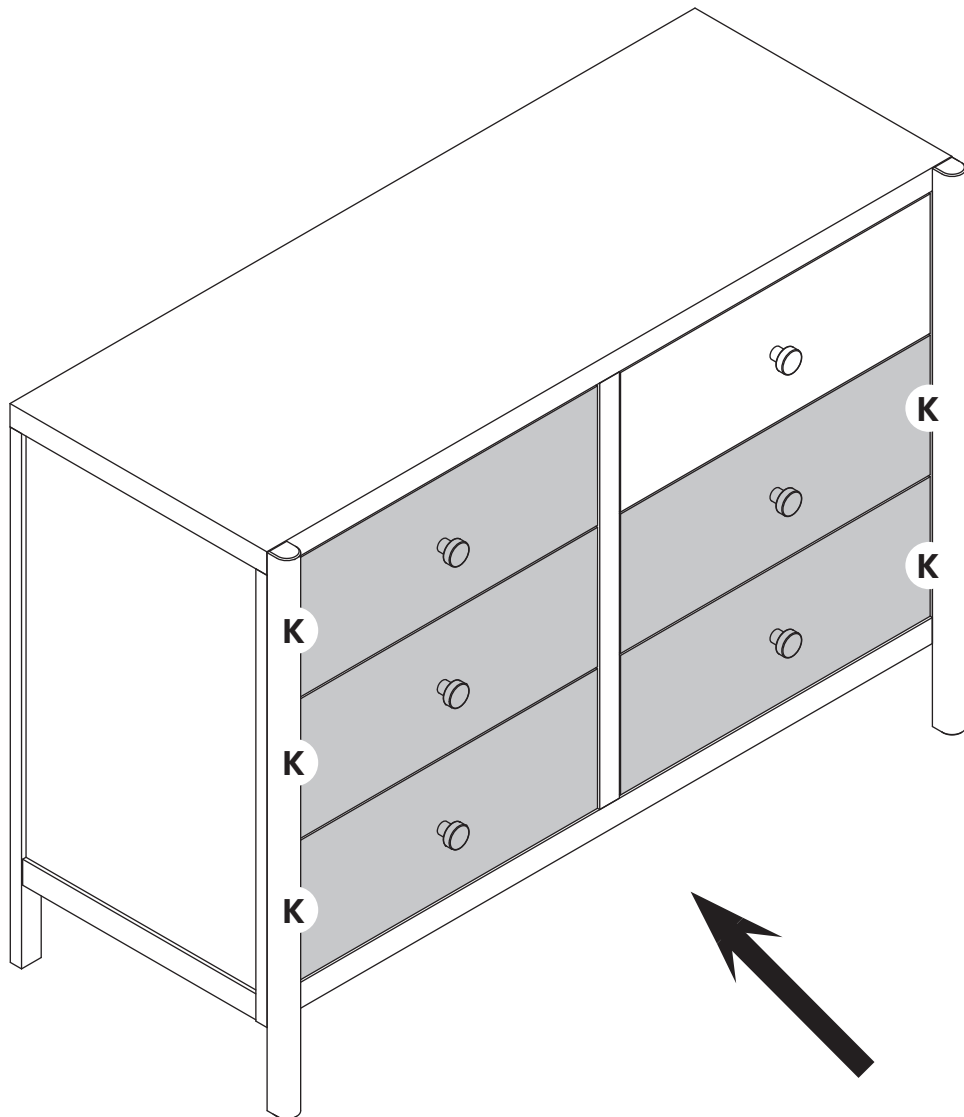
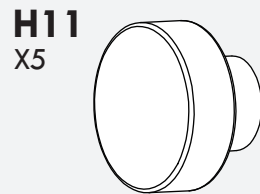
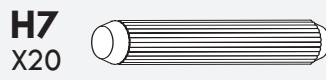
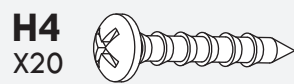
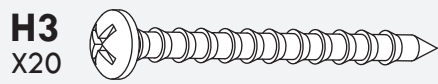

You did it!



¡Lo logró!

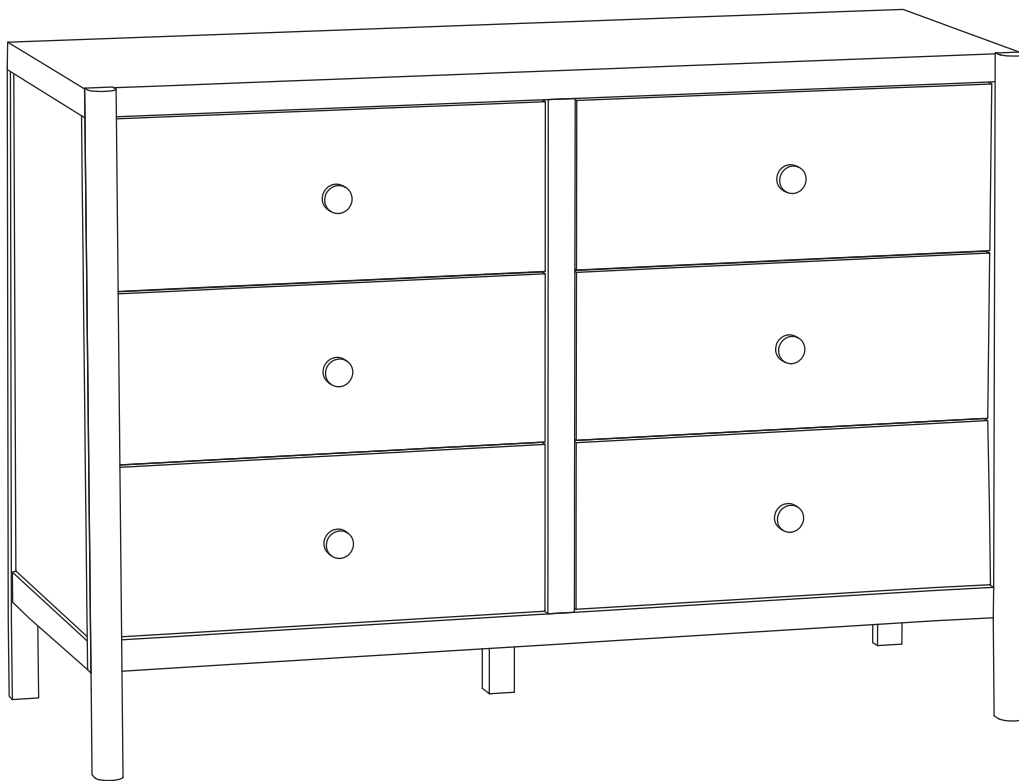

Vous y êtes!



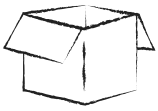

STORAGE

Because materials respond to temperature and humidity, it is important to store furniture in controlled environments. Furniture should not be placed in direct sunlight or near air-conditioning outlets, radiators, heaters, or humidifiers. Any changes such as extreme heat or cold, dampness, or dryness, may cause noticeable shrinkage or swelling of wood. Direct sunlight may affect the coloring of materials over time.



CARE & CLEANING

To clean wood or metal parts, use a lint-free, soft cloth with a non-toxic cleaner. Wipe dry immediately. To avoid scratches or other damages, do not use abrasive chemicals or materials. For fabrics, we recommend using a non-toxic foaming fabric cleaner or leather cleaner where appropriate. Touch up kits are available for purchase by contacting us:

323-768-0183

davincibaby.com/parts



REGISTRATION

Registering your product is simple:

davincibaby.com/registrations



PART REPLACEMENT

If you would like to order replacement or missing parts, please visit us:

davincibaby.com/parts

You can contact us by mail at,
8700 Rex Rd. Pico Rivera, CA 90660

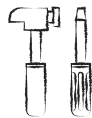

ONE YEAR LIMITED WARRANTY

Have an issue? We're here to help. Your DaVinci product is covered under warranty for one year after the date of purchase. Visit us for more details on our warranty policy:

davincibaby.com/warranty

*** CHANGER TRAY IS NOT INCLUDED, SOLD SEPARATELY.
CHANGER TRAY M0219 OR M0619 IS RECOMMENDED.**

**READ ALL INSTRUCTIONS BEFORE USING THE PRODUCT.
KEEP THE INSTRUCTIONS FOR FUTURE USE.**

KEEP THIS MANUAL IN A SAFE PLACE FOR FUTURE REFERENCE.
Recheck all screws and bolts to be sure they are fastened securely. **Do not overtighten.**



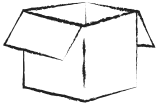

ALMACENAMIENTO

Dado que los materiales responden a la temperatura y la humedad, es importante guardar muebles en ambientes controlados. No deben ponerse los muebles a la luz solar directa ni cerca de salidas de aire acondicionado, radiadores, calefactores ni humidificadores. Cualquier cambio como los extremos de calor o frío, humedad o sequedad, pueden causar notoriamente encogimiento o hinchazón en la madera. La luz solar directa puede afectar la coloración de los materiales con el paso del tiempo.



CUIDADO Y LIMPIEZA

Para limpiar piezas de madera o metal, use un paño suave sin pelusa con un limpiador no tóxico. Seque con un paño inmediatamente. Para evitar rayar o dañar la superficie, no use agentes químicos ni materiales abrasivos. En cuanto a las telas, recomendamos usar una espuma limpiadora no tóxica para telas o un limpiador para cuero según corresponda. Hay kits para retocar disponibles para la venta contactándonos:

323-768-0183

davincibaby.com/parts



REGISTRARSE

Es sencillo registrar su producto:
davincibaby.com/registrations



RECAMBIO DE PIEZAS

Si quisiera pedir repuestos o piezas faltantes, visítenos en:

davincibaby.com/parts

o puede contactarnos por correo en:
8700 Rex Rd. Pico Rivera, CA 90660

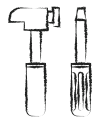

GARANTÍA LIMITADA DE UN AÑO

¿Tiene algún problema? Estamos aquí para ayudar. Su producto DaVinci está cubierto por una garantía de un año a partir de la fecha de compra. Para conocer más detalles sobre nuestra política de garantía, visite:

davincibaby.com/warranty

*** LA BANDEJA DEL MUDADOR NO ESTÁ INCLUIDA, SE VENDE POR SEPARADO. SE RECOMIENDA LA BANDEJA DEL MUDADOR M0219 O M0619.**

LEA TODAS LAS INSTRUCCIONES ANTES DE USAR EL PRODUCTO. GUARDE LAS INSTRUCCIONES PARA USO FUTURO.

MANTENGA ESTE MANUAL EN UN LUGAR SEGURO PARA REFERENCIA A FUTURO. Vuelva a revisar todos los tornillos y pernos para asegurarse de que estén bien sujetos. **No apriete demasiado.**



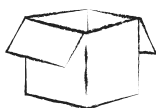

RANGEMENT

Compte tenu que les matériaux réagissent à la température et à l'humidité, il importe de ranger le mobilier dans des environnements contrôlés. Le mobilier ne doit pas être placé en plein soleil ni près des sorties d'air climatisé, des radiateurs, des appareils de chauffage ou des humidificateurs. Tout changement comme un froid ou une chaleur extrême, de l'humidité ou de la sécheresse pourrait causer la contraction ou le gonflement du bois. La lumière directe du soleil peut altérer la couleur des matériaux au fil du temps.



NETTOYAGE ET ENTRETIEN

Pour nettoyer le bois ou les pièces métalliques, utilisez un chiffon doux sans peluche et un produit nettoyant non toxique. Essuyez immédiatement. Pour éviter les égratignures ou autres dommages, veillez à ne pas utiliser des produits chimiques ou des matériaux abrasifs. Pour les tissus, il est recommandé d'utiliser un produit nettoyant pour tissus non toxique ou pour cuir le cas échéant. Il est possible de se procurer des nécessaires de retouches en nous contactant:

323-768-0183

davincibaby.com/parts



ENREGISTREMENT

L'enregistrement du produit est simple à réaliser:

davincibaby.com/registrations



PIÈCES DE RECHANGE

Pour commander des pièces de rechange ou manquantes, veuillez visiter:

davincibaby.com/parts

ou communiquer avec nous par courriel à l'adresse:

8700 Rex Rd. Pico Rivera, CA 90660

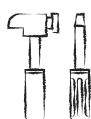

GARANTIE LIMITÉE D'UN AN

Vous avez un problème? Nous sommes là pour vous aider. Votre produit DaVinci est couvert par une garantie d'un an à compter de la date d'achat. Pour plus de détails sur la politique de garantie, veuillez visiter:

davincibaby.com/warranty

*** LA TABLE À LANGER N'EST PAS INCLUSE. ELLE EST VENDUE SÉPARÉMENT. IL EST RECOMMANDÉ D'UTILISER LA TABLE À LANGER M0219 OU M0619.**

LISEZ ATTENTIVEMENT TOUTES LES INSTRUCTIONS AVANT D'UTILISER CE PRODUIT. CONSERVER CES INSTRUCTIONS POUR UN USAGE ULTÉRIEUR.

GARDER CE MANUEL EN LIEU SÛR POUR UN USAGE ULTÉRIEUR. Procéder à une nouvelle vérification des vis et des boulons pour s'assurer qu'ils sont bien fixés. **Ne pas trop serrer.**



