





HEKMAN®

A HOWARD MILLER COMPANY

ASSEMBLY INSTRUCTION FOR 24901 COFFEE TABLE

HARDWARE LIST

NO.	ITEM	DESCRIPTIN	QTY.
1		JCB Bolt M6 X20 MM	16
2		Flat washer M6X18 MM	8
3		Flat washer M6X25 MM	8
4		Allen wrench	1

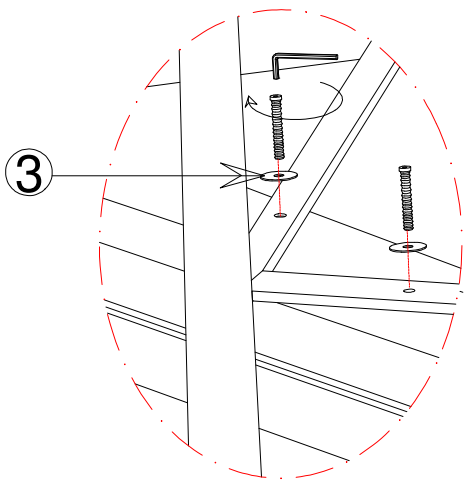
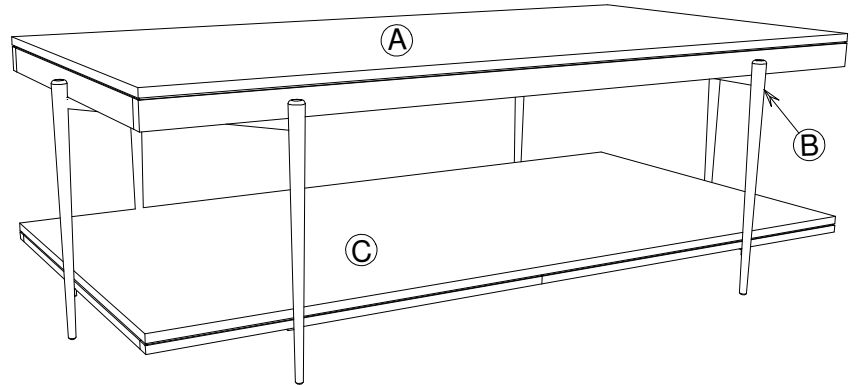

DETAIL: 2.1

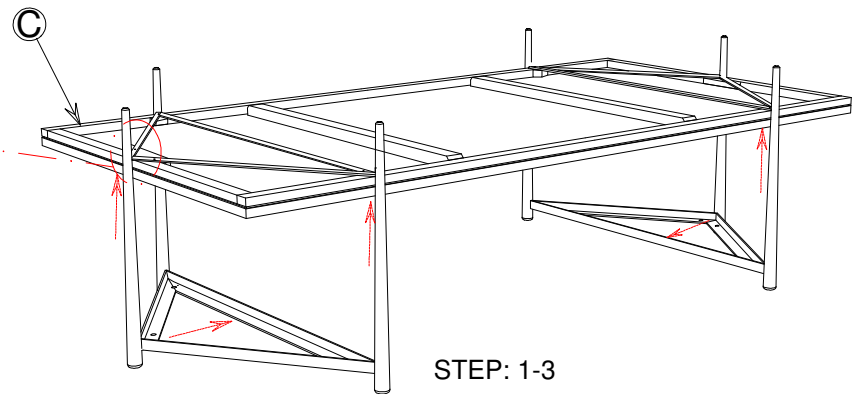

STEP: 1-3

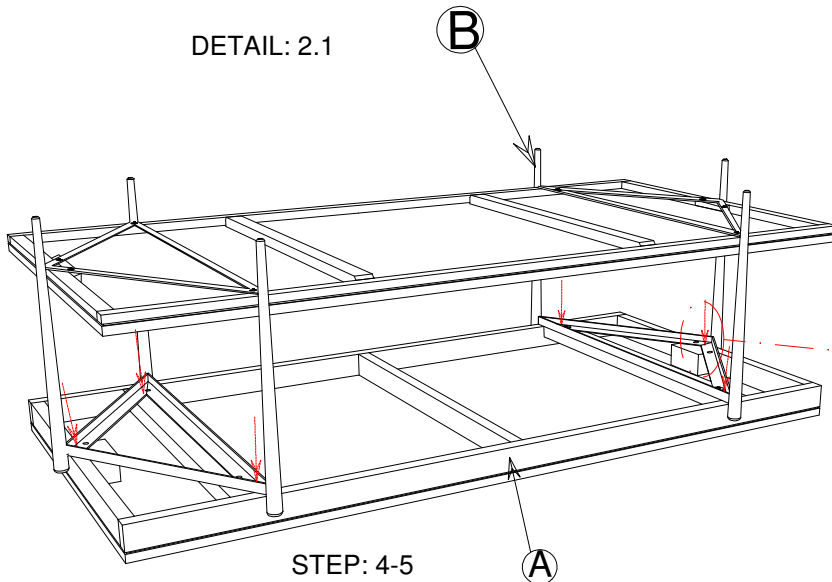

STEP: 4-5

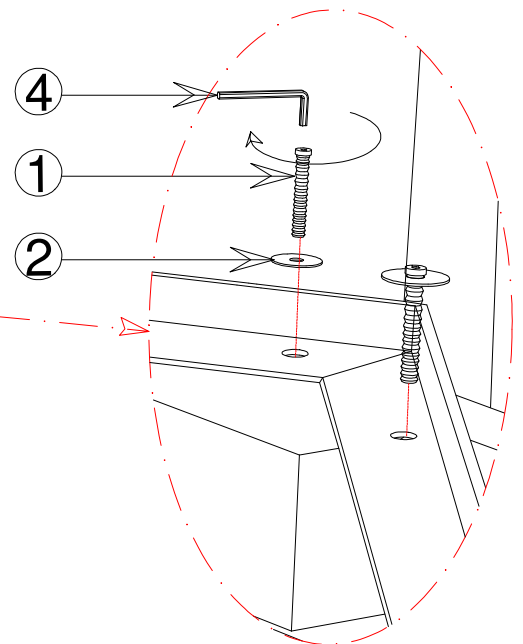

TO ASSEMBLY :

- STEP 1 : Unpack rect table and turn the bottom shelf (c) upside down .
- STEP 2 : Align holes in legs (B) with holes on side of bottom shelf (c) as shown in detail:2.1
- STEP 3 : Thread JCB bolt (1) to leg (B), using flat washer(3) . Do not tighten end assemblies fully
- STEP 4 : Attach the top (A) to legs (B) , and align the holes
- STEP 5 : Thread JCB bolt (1) to leg (B), using flat washer(2) . Do not tighten end assemblies fully
- STEP 6 : Tighten bolts in step 3 & 5 fully with allen wrench (4) then carefully turn the table upright.