

# ELKAY®

## Installation/Care/Use Manual ezH2O® In Wall Bottle Filling Station

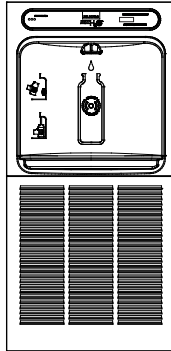

LZWSM8\*  
EZWSM8\*

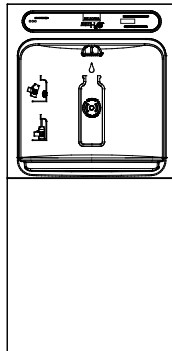

LZWSMD\*  
EZWSMD\*

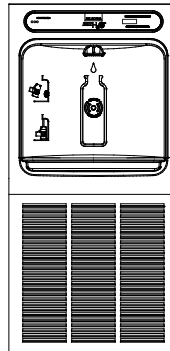

LZWSM8P\*  
EZWSM8P\*

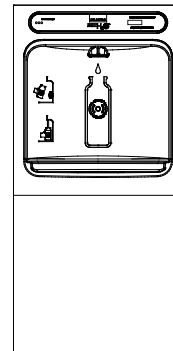

LZWSMDP\*  
EZWSMDP\*

### Installer

To assure you install this model easily and correctly, PLEASE READ THESE SIMPLE INSTRUCTIONS BEFORE STARTING THE INSTALLATION. CHECK YOUR INSTALLATION FOR COMPLIANCE WITH PLUMBING, ELECTRICAL AND OTHER APPLICABLE CODES. After installation, leave these instructions inside the fountain for future reference.

### IMPORTANT

ALL SERVICE TO BE PERFORMED BY AN AUTHORIZED SERVICE PERSON

### IMPORTANT! INSTALLER PLEASE NOTE.

THE GROUNDING OF ELECTRICAL EQUIPMENT SUCH AS TELEPHONE, COMPUTERS, ETC. TO WATER LINES IS A COMMON PROCEDURE. THIS GROUNDING MAY BE IN THE BUILDING OR MAY OCCUR AWAY FROM THE BUILDING. THIS GROUNDING CAN CAUSE ELECTRICAL FEEDBACK INTO A FOUNTAIN, CREATING AN ELECTROLYSIS WHICH CAUSES A METALLIC TASTE OR AN INCREASE IN THE METAL CONTENT OF THE WATER. THIS CONDITION IS AVOIDABLE BY USING THE PROPER MATERIALS AS INDICATED. ANY DRAIN FITTINGS PROVIDED BY THE INSTALLER SHOULD BE MADE OF PLASTIC TO ELECTRICALLY ISOLATE THE FOUNTAIN FROM THE BUILDING PLUMBING SYSTEM. WE SUGGEST THAT THE BOTTLE FILLER BE PROTECTED BY A GROUND FAULT CIRCUIT INTERRUPTER (GFCI)

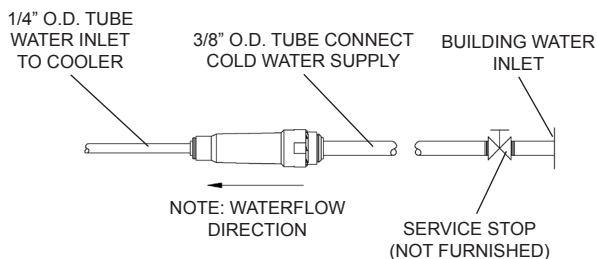

Fig. 1

### OPERATION OF QUICK CONNECT FITTINGS

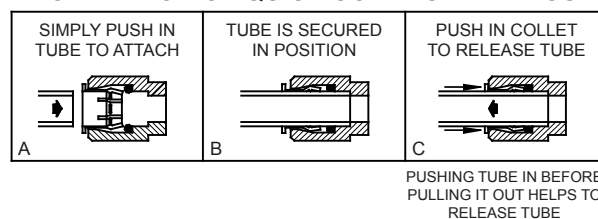

Fig. 2

# LZWSM8\*, LZWSMD\* EZWSM8\*, EZWSMD\* ROUGH-IN

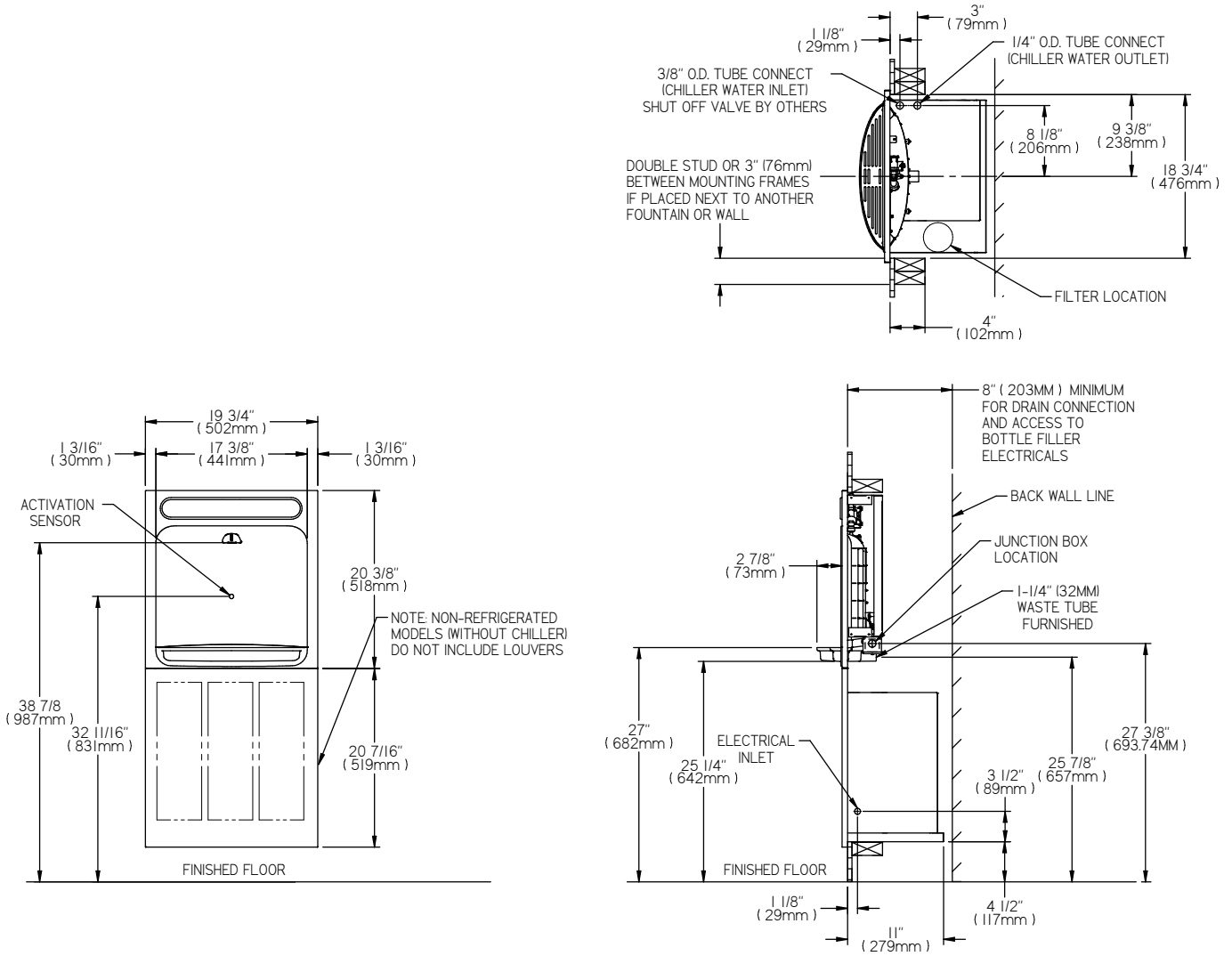

Fig. 3

# LZWSM8P\*, LZWSMDP\* EZWSM8P\*, EZWSMDP\* ROUGH-IN

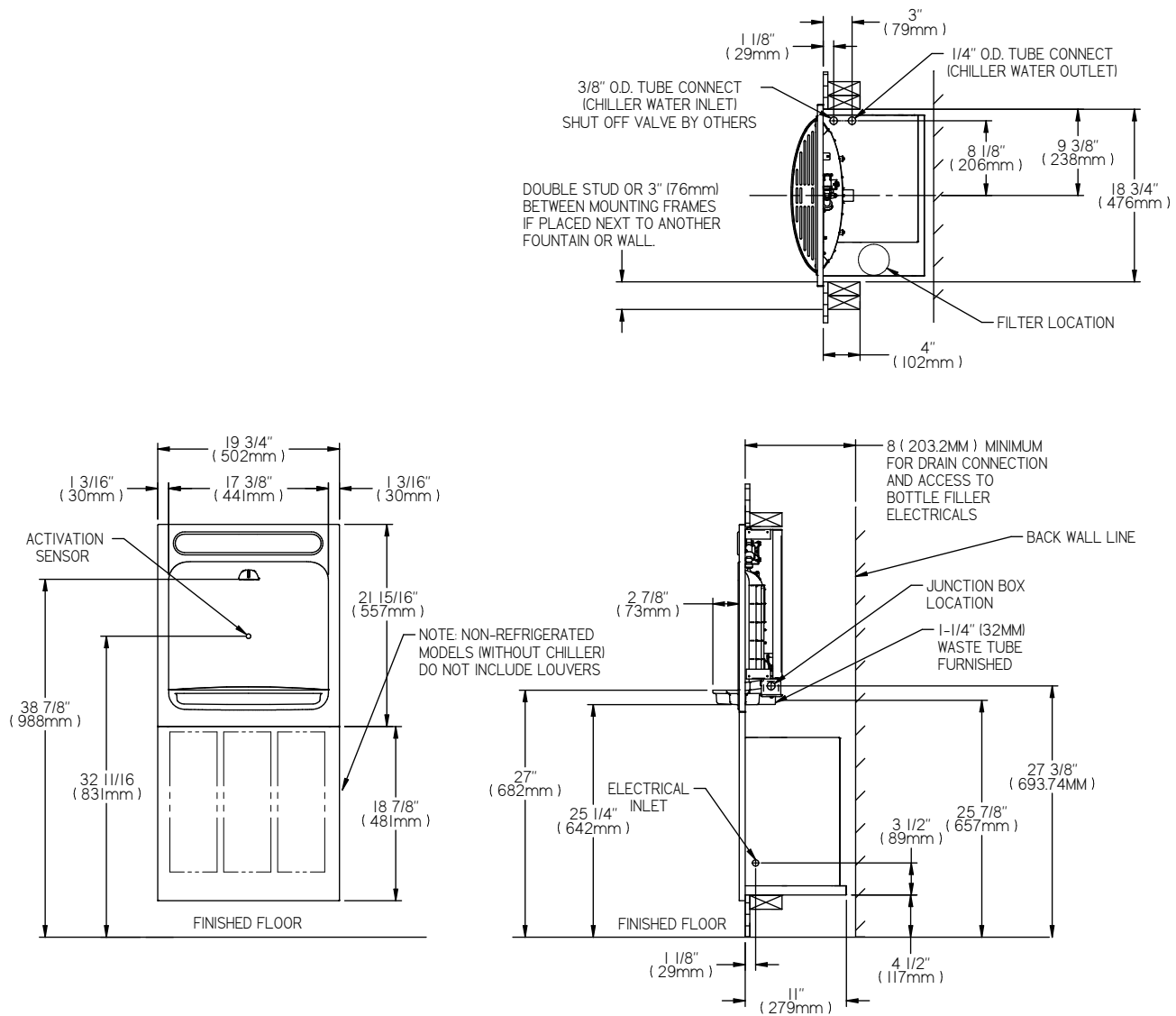
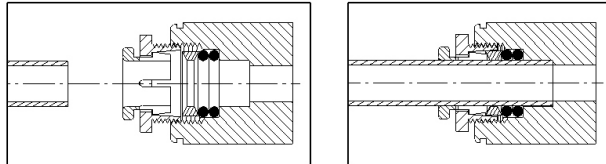

Fig. 4

## INSTALLATION INSTRUCTIONS

1. **Install** mounting frame and chiller shelf. See mounting frame instructions.
2. **Mount the upper BF panel to the mounting frame:** Mount upper panel by aligning holes in the hinge brackets with holes in the mounting frame (three places). Mount with adequate size screws (not provided). Close the door and verify that the lock brackets on the side and bottom of the panel align with the slots on the mounting frame. Also verify that the panel is hanging high enough that it covers the top of the mounting frame.
3. **Mount the lower Chiller panel to the mounting frame:** Mount the lower panel by aligning holes in the hinge brackets with holes in the mounting frame (three places). Mount with adequate size screws (not provided). Close the door and verify that the lock brackets on the side of the panel align with the slots on the mounting frame. If adjustments need to be made, open the doors to make adjustments. Open panels for adjustments. Loosen the (4) screws on the hinges of each panel and adjust accordingly and then re-tighten screws. Close and Lock the top panel in place using two set screws (provided) on the side of the panel, and a ¼ x 20 bolt through the front of the panel into the nut in the frame.
4. **Attach drain:** Attach the drain fittings to drain tube. Attach elbow to p-trap and cut waste tube to required length using plumbing hardware and trap as a guide.
5. **Install remote chiller:** See chiller instructions. Remove protective caps from water lines on chiller.



**NOTE: SCREW THE LOCK-NUT HAND TIGHT TO SEAL**  
Fig. 5

**EW3000 WATERSENTRY PLUS FILTER INSTALLATION** (Fig. 6): (Filter units only. For non-filtered units proceed to step 15)

**NOTICE:** Do not use water that is microbiologically unsafe or of unknown quality without adequate disinfection before or after the system.

**CAUTION:** If supply pressure will ever exceed 100 psi, install a pressure regulator set to 100 psi or below.

**DO NOT ATTACH HOT WATER LINE TO FILTER HEAD.**

Filter kits must be installed in compliance with all state and local laws and regulations governing the installation and use of this product.

Maximum inlet water temperature: 100°F (38°C).

**See filter instructions for filter head assembly.**

6. **Connect Filter Kit:** Using the filter mounting bracket and screws supplied, mount filter head using the (3) screw holes on the side of the chiller. Allow enough room under the filter head for the installation and removal of the filter cartridge (13" minimum). To make tube connections on the filter head, loosen locknut. Push the tube end past both O-rings to a positive stop in the filter head recess - approx. 1". Screw the locknut hand tight to seal (See Fig. 5). Ends of tubing must be cut square and free of burrs and sharp ends that could cut or nick the O-rings.
7. **Connect filter water outlet:** Connect the outlet of the filter head to the inlet of the chiller using the ¼" O.D. poly tubing and ¼" elbow union supplied.
8. **Place Chiller on Shelf:** When mounting unit in a cavity or behind a wall maintain a minimum space of 4" (102mm) on top, sides and a depth of 12" (305mm).
9. **Connect bottle filter line:** Connect water line from BF station by inserting the ¼" O.D. poly tubing into union on the chiller outlet.
10. **Remove Chiller Front panel:** Remove the (10) screws securing chiller front panel.

### PLUMBING DIAGRAM

Fig. 6

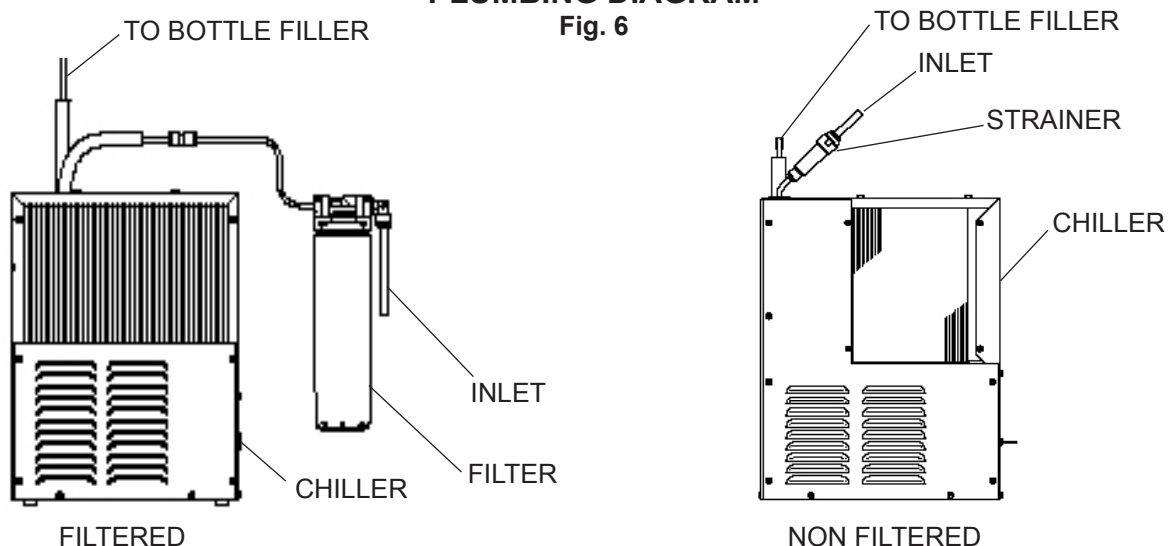

11. **Connect electrical to chiller:** Make sure power supply is identical in voltage, cycle and phase to that specified on cooler serial plate. Never wire Compressor directly to the power supply. While chiller panel is off, adjust cold control if needed.
  12. **Replace chiller panel:** Using the (10) screws re-secure the panel.
  13. **Plug bottle filler into wall box receptacle.**
  14. **Install a shut-off valve:** Install a shut-off valve and union connection to building water supply (valve and union not provided). Connect 3/8" shut-off valve to 3/8" copper tubing inlet of filter head.
  15. **Install filter cartridge:** remove filter from carton, remove protective cap, and attach filter to filter head by firmly inserting into head and rotating filter clockwise.
  16. **Go to step 18.**
- EW3000 WATERSENTRY STRAINER INSTALLATION (Fig. 6):**
17. **For non-filtered units:** Install a shut-off valve and union connection to building water supply (valve and union not provided). Turn on the water supply and flush the line thoroughly. Turn off water supply. Install the in-line strainer between the valve and the chiller. The in-line strainer is not installed on filtered units.
  18. **Connect water supply line:** Connect 3/8" shut-off valve to 3/8" copper tubing to inlet of strainer. Connect water line from BF station by inserting the 1/4" O.D. poly tubing into union on the chiller outlet. Turn on water supply and check for leaks.
  19. **Place Chiller on Shelf:** When mounting unit in a cavity or behind a wall maintain a minimum space of 4" (102mm) on top, sides and a depth of 12" (305mm).
  20. **Remove Chiller Front panel:** Remove the (10) screws securing chiller front panel.
  21. **Connect electrical to chiller:** Make sure power supply is identical in voltage, cycle and phase to that specified on cooler serial plate. Never wire Compressor directly to the power supply. While chiller panel is off, adjust cold control if needed. Replace chiller panel: Using the (10) screws re-secure the panel.
  22. **Turn on water supply:** Turn on the water supply, plug unit into wall (power cord not supplied on 220V models) and activate the electronic eye on in-wall bottle filler until approximately 1 gallon of water is dispensed. Be sure to reinstall fuse to the circuit or switch the circuit breaker back to the "ON" position. Once power is applied to Bottle Filler, the GREEN LED LIGHT and/or LCD Bottle Counter should illuminate, the green light showing good filter status Please. note that the electric eye activation times out at 20 seconds and will need to be activated repeatedly until 1 gallon has been passed. This flushing procedure purges air and fine carbon particles from filter and strainer. When 1 gallon of water has been purged through the bottle filler, carefully inspect all water connections for leaks.
  23. **Verify** proper dispensing by placing cup, hand, or any opaque object in front of sensor area and verify water dispenses.
  24. **Close** and lock the lower panel in place using two set screws (provided) on the side of the panel.
  25. **Installation Complete.**

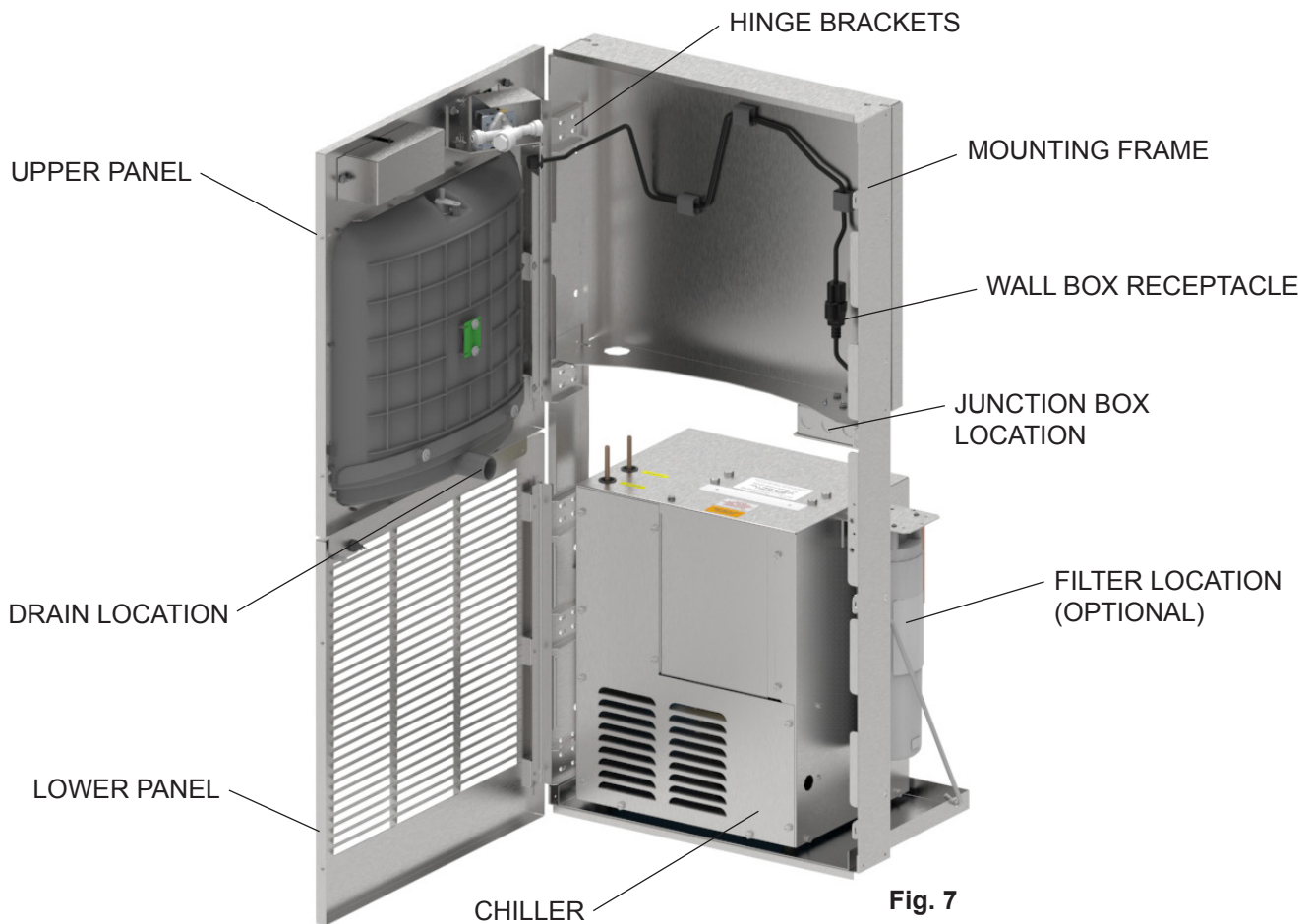

Fig. 7

## **BF6-BF7-BF8 PROGRAMS** **SETTING THE CONTROL BOARD**

### **VERIFY CONTROL BOARD SOFTWARE**

- 1) To verify the software program of the control board the unit will need to be shut down and restarted. The chiller (if present) does not need to be shut down and restarted.
- 2) The units lower panel must be open to access the power cord and wall outlet.
- 3) Shut down the unit by unplugging the power cord from the wall outlet.
- 4) Restart the unit by plugging the power cord back into the wall outlet.
- 5) Upon start up the bottle count display will show the software designation of BF6, BF7, BF8, BF9 or BF11.
- 6) Reference the BF6-BF7-BF8-BF9 or BF11 instructions for setting the control board.

### **ACCESSING THE PROGRAMMING BUTTON**

- 1) To access the program button the lower panel of the unit must be opened. The programming button is located at the bottom right corner of the upper panel. This area of the unit is concealed by the lower panel.

### **RESET THE FILTER MONITOR**

- 1) Instructions apply to filtered units only.
- 2) Depress the program button for approximately 2 seconds until the display changes then release. The display will change and scroll through three messages:  
**"RST FLTR"** – Reset Filter Status LED  
**"RST BCNT"** – Reset Bottle Count  
**"RNG SET"** – Range Set for IR Sensor  
 If the program button is not pushed again the display will scroll through the three messages above for three cycles and then default back to bottle count and be back in run mode.
- 3) When the display changes to "RST FLTR", depress the button again. The display will change to show "FLT=". Depress the button again and the display will show "FLTR=0".
- 4) The green LED should now be illuminated indicating that the visual filter monitor has been reset.

### **SETTING RANGE OF THE IR SENSOR**

- 1) Depress the program button for approximately 2 seconds until the display changes then release. The display will change and scroll through three messages:  
**"RST FLTR"** – Reset Filter Status LED  
**"RST BCNT"** – Reset Bottle Count  
**"RNG SET"** – Range Set for IR Sensor
- 2) If the program button is not pushed again the display will scroll through the two messages above for three cycles and then default back to bottle count and be back in run mode.
- 3) When display shows "RNG SET" push program button once the display will show current value (can be 1 – 10) e.g. **"RNG = 3"**.
- 4) Once display shows current value push the program button to scroll through value of 1 – 10. Select the desired range setting.
- 5) Once range is selected allow approximately 4 seconds to pass and then the display will go back to bottle counter and be in run mode.
- 6) Test bottle filler by placing bottle or hand in front of sensor to make sure water is dispensed.

### **RESETTING BOTTLE COUNT**

- 1) Depress the program button for approximately 2 seconds until the display changes then release. The display will change and scroll through two messages:  
**"RST FLTR"** – Reset Filter Status LED  
**"RST BCNT"** – Reset Bottle Count  
**"RNG SET"** – Range Set for IR Sensor  
 If the program button is not pushed again the display will scroll through the two messages above for three cycles and then default back to bottle count and be back in run mode.
- 2) When the display changes to "RST BCNT", depress the button again. The display will change to show current bottle count value e.g. "00033183".
- 3) Depress the button again and the display will change to "BTLCT=0" for approximately 2 seconds and then return to run mode displaying 00000000.
- 4) You can test the bottle counter by running water approximately 5 seconds to see bottle counter advance 1.

## **BF9 PROGRAM**

### **SETTING THE CONTROL BOARD**

#### **VERIFY CONTROL BOARD SOFTWARE**

- 1) To verify the software program of the control board the unit will need to be shut down and restarted. The chiller (if present) does not need to be shut down and restarted.
- 2) The units lower panel must be open to access the power cord and wall outlet.
- 3) Shut down the unit by unplugging the power cord from the wall outlet.
- 4) Restart the unit by plugging the power cord back into the wall outlet.
- 5) Upon start up the bottle count display will show the software designation of BF6, BF7, BF8, BF9 or BF11.
- 6) Reference the BF6-BF7-BF8-BF9 or BF11 instructions for setting the control board.

#### **ACCESSING THE PROGRAMMING BUTTON**

- 1) To access the program button the lower panel of the unit must be opened. The programming button is located at the bottom right corner of the upper panel. This area of the unit is concealed by the lower panel.

#### **RESET THE FILTER MONITOR**

- 1) Instructions apply to filtered units only.
- 2) Depress the program button for approximately 2 seconds until the display changes then release. The display will change and scroll through two messages:  
"RST FLTR" – Reset Filter Monitor  
"SETTINGS" – System Settings Sub Menu  
If the program button is not pushed again the display will scroll through the two messages above for three cycles and then default back to bottle count and be back in run mode.
- 3) When the display changes to "RST FLTR", depress the button again. The display will change to show "FLTR =". Depress the button again and the display will show "FLTR =0"
- 4) The Green LED should be illuminated indicating that the visual filter monitor has been reset.

#### **SETTING RANGE OF THE IR SENSOR**

- 1) Depress the program button for approximately 2 seconds until the display changes then release. The display will change and scroll through two messages:  
"RST FLTR" – Reset Filter Status LED  
"SETTINGS" – System Settings Sub Menu  
If the program button is not pushed again the display will scroll through the two messages above for three cycles and then default back to bottle count and be back in run mode.
- 2) When the display changes to "SETTINGS", depress the button again. The display will change to show "RNG SET"- Range set for IR sensor.  
"UNIT TYP" - Type of unit (REFRIG or NON-RFRG)  
"RST BCNT" - Reset bottle count
- 3) When display shows "RNG SET" push program button once the display will show current value (can be 1 – 10) e.g. "RNG = 3".
- 4) Once display shows current value push the program button to scroll through value of 1 – 10. Select the desired range setting.
- 5) Once range is selected allow approximately 4 seconds to pass and then the display will go back to bottle counter and be in run mode.
- 6) Test bottle filler by placing bottle or hand in front of sensor to make sure water is dispensed.

#### **SETTING UNIT TYPE**

- 1) Depress the program button for approximately 2 seconds until the display changes then release. The display will change and scroll through two messages:  
"RST FLTR" – Reset Filter Status LED  
"SETTINGS" – System Settings Sub Menu  
If the program button is not pushed again the display will scroll through the two messages above for three cycles and then default back to bottle count and be back in run mode.
- 2) When the display changes to "SETTINGS", depress the button again. The display will change to show "RNG SET"- Range set for IR sensor.  
"UNIT TYP" - Type of unit (REFRIG or NON-RFRG)  
"RST BCNT" - Reset bottle count
- 3) When display shows "UNIT TYPE" push program button once the display will show current value  
Can be REFRIG or NON-RFRG
- 4) Push button once to change value. Once value is selected the display will show the new value.  
(Can be REFRIG or NON-RFRG)  
"REFRIG" - stands for refrigerated product. In this setting the flow rate is estimated at 1.0 gallon per minute.  
"NON-RFRG" - stands for nonrefrigerated product. In this setting the flow rate is estimated at 1.5 gallons per minute.  
Both "REFRIG" and "NON-RFRG" simulate 1 bottle equal to 20 oz.
- 5) Allow approximately 4 seconds to pass and the display will return to bottle counter and be in run mode.

#### **RESETTING BOTTLE COUNT**

- 1) Depress the program button for approximately 2 seconds until the display changes then release. The display will change and scroll through two messages:  
"RST FLTR" – Reset Filter Status LED  
"SETTINGS" – System Settings Sub Menu  
If the program button is not pushed again the display will scroll through the two messages above for three cycles and then default back to bottle count and be back in run mode.
- 2) When the display changes to "SETTINGS", depress the button again. The display will change to show "RNG SET"- Range set for IR sensor.  
"UNIT TYP" - Type of unit (REFRIG or NON-RFRG)  
"RST BCNT" - Reset bottle count  
If the button is not pushed again the display will scroll through the three messages above for the cycles and return to run mode.
- 3) When display shows "RST BCNT" push program button once the display will show current value e.g. "00033183".
- 4) Once display shows current value push the program button once more to reset back to 0. The display will show BTLCT = 0 for approximately 2 seconds and then return to run mode showing 00000000 bottles.
- 5) Testing the bottle counter:  
REFRIG units: Place bottle or hand in front of sensor for 9.4 seconds to see bottle counter count 00000001.  
(This is based on filling a 20 oz. bottle)  
NON-RFRG units: Place bottle or hand in front of sensor for 6.25 seconds to see bottle counter count 00000001.  
(This is based on filling a 20 oz bottle)

## BF11 - BF12 PROGRAM

### SETTING THE CONTROL BOARD

#### VERIFY CONTROL BOARD SOFTWARE

- 1) To verify the software program of the control board the unit will need to be shut down and restarted. The chiller (if present) does not need to be shut down and restarted.
- 2) The units lower panel must be open to access the power cord and wall outlet.
- 3) Shut down the unit by unplugging the power cord from the wall outlet or switching off the circuit breaker to the unit.
- 4) Restart the unit by plugging the power cord back into the wall outlet or by switching on the circuit breaker to the unit.
- 5) Upon start up, the bottle count display will show the software designation of BF11 or BF12.

#### ACCESSING THE PROGRAMMING BUTTON

- 1) To access the program button, open the lower panel. Reset button is located at the lower right hand side of the top panel.

#### RESET THE FILTER MONITOR

- 1) Instructions apply to filtered units only.
- 2) Depress the program button for approximately 2 seconds until the display changes then release. The display will change and scroll through two messages:  
"RST FLTR" – Reset Filter Monitor  
"SETTINGS" – System Settings Sub Menu  
If the program button is not pushed again the display will scroll through the two messages above for three cycles and then default back to bottle count and be back in run mode.
- 3) When the display changes to "RST FLTR", depress the button again. The display will change to show "FLTR =". Depress the button again and the display will show "FLTR =0"
- 4) The Green LED should be illuminated indicating that the visual filter monitor has been reset.

#### SETTING RANGE OF THE IR SENSOR

- 1) Depress the program button for approximately 2 seconds until the display changes then release. The display will change and scroll through two messages:  
"RST FLTR" – Reset Filter Status LED  
"SETTINGS" – System Settings Sub Menu  
If the program button is not pushed again the display will scroll through the two messages above for three cycles and then default back to bottle count and be back in run mode.
- 2) When the display changes to "SETTINGS", depress the button again. The display will change to show  
"RNG SET" - Range set for IR sensor.  
"UNIT TYP" - Type of unit (REFRIG or NON-RFRG)  
"FLT SIZE" - Select filter capacity  
"RST BCNT" - Reset bottle count
- 3) When display shows "RNG SET" push program button once the display will show current value (can be 1 – 10) e.g. "RNG = 3".
- 4) Once display shows current value push the program button to scroll through value of 1 – 10. Select the desired range setting, "1" being closest to sensor and "10" being farthest away.
- 5) Once range is selected allow approximately 4 seconds to pass and then the display will go back to bottle counter and be in run mode.
- 6) Test bottle filler by placing bottle or hand in front of sensor to make sure water is dispensed.

#### SETTING UNIT TYPE

- 1) Depress the program button for approximately 2 seconds until the display changes then release. The display will change and scroll through two messages:  
"RST FLTR" – Reset Filter Status LED  
"SETTINGS" – System Settings Sub Menu  
If the program button is not pushed again the display will scroll through the two messages above for three cycles and then default back to bottle count and be back in run mode.

Continued from below:

- 2) When the display changes to "SETTINGS", depress the button again.  
The display will change to show  
"RNG SET" - Range set for IR sensor.  
"UNIT TYP" - Type of unit (REFRIG or NON-RFRG)  
"FLT SIZE" - Select filter capacity  
"RST BCNT" - Reset bottle count
- 3) When display shows "UNIT TYPE" push program button once the display will show current value. Can be REFRIG or NON-RFRG
- 4) Push button once to change value. Once value is selected the display will show the new value. (Can be REFRIG or NON-RFRG)  
"REFRIG" - stands for refrigerated product. In this setting the flow rate is estimated at 1.0 gallon per minute.  
"NON-RFRG" - stands for nonrefrigerated product. In this setting the flow rate is estimated at 1.5 gallons per minute. Both "REFRIG" and "NON-RFRG" simulate 1 bottle equal to 20 oz.
- 5) Allow approximately 4 seconds to pass and the display will return to bottle counter and be in run mode.

#### RESETTING BOTTLE COUNT

- 1) Depress the program button for approximately 2 seconds until the display changes then release. The display will change and scroll through two messages:  
"RST FLTR" – Reset Filter Status LED  
"SETTINGS" – System Settings Sub Menu  
If the program button is not pushed again the display will scroll through the two messages above for three cycles and then default back to bottle count and be back in run mode.
- 2) When the display changes to "SETTINGS", depress the button again.  
The display will change to show:  
"RNG SET"- Range set for IR sensor.  
"UNIT TYP" - Type of unit (REFRIG or NON-RFRG)  
"FLT SIZE" - Select filter capacity  
"RST BCNT" - Reset bottle count  
If the button is not pushed again the display will scroll through the four messages above for three cycles and return to run mode.
- 3) When display shows "RST BCNT" push program button once the display will show current value, e.g. "0033183".
- 4) Once display shows current value push the program button once more to reset back to 0. The display will show BTLCCT = 0 for approximately 2 seconds and then return to run mode showing 00000000 bottles.  
**NOTE: Once the bottle count is reset to zero there is no way to return to the previous bottle count.**
- 5) Testing the bottle counter:  
REFRIG units: Place bottle or hand in front of sensor for approximately 9 seconds to see bottle counter count 00000001,  
(This is based on filling a 20 oz. bottle).  
NON-RFRG units: Place bottle or hand in front of sensor for approximately 6 seconds to see bottle counter count 00000001,  
(This is based on filling a 20 oz bottle).

#### SETTING FILTER CAPACITY

- 1) Depress the program button for approximately 2 seconds until the display changes then release. The display will change and scroll through two messages:  
"RST FLTR" – Reset Filter Status LED  
"SETTINGS" – System Settings Sub Menu  
If the program button is not pushed again the display will scroll through the two messages above for three cycles and then default back to bottle count and be back in run mode.
- 2) When the display changes to "SETTINGS", depress the button again.  
The display will change to show:  
"RNG SET"- Range set for IR sensor.  
"UNIT TYP" - Type of unit (REFRIG or NON-RFRG)  
"FLT SIZE" - Select filter capacity  
"RST BCNT"- Reset bottle count  
If the button is not pushed again the display will scroll through the four messages above for three cycles and return to run mode.
- 3) When display shows "FLT SIZE" push program button once. The display will show current value. Can be 3000GAL or 6000GAL.
- 4) Push program button again to display the desired "FLT SIZE".
- 5) Allow approximately 4 seconds to pass and the display will return to bottle counter and be in run mode.

FILTER PARTS LIST (See Fig. 8)		
ITEM NO.	PART NO.	DESCRIPTION
1	51300C	Filter Assy-3000 Gal.
2	98926C	Kit-Filter Head Fittings-includes John Guest Fittings
3	51469C	Assy-Filter & Brkt includes Filtr Head/Mtg Bkt/ John Guest Ftgs/Screws

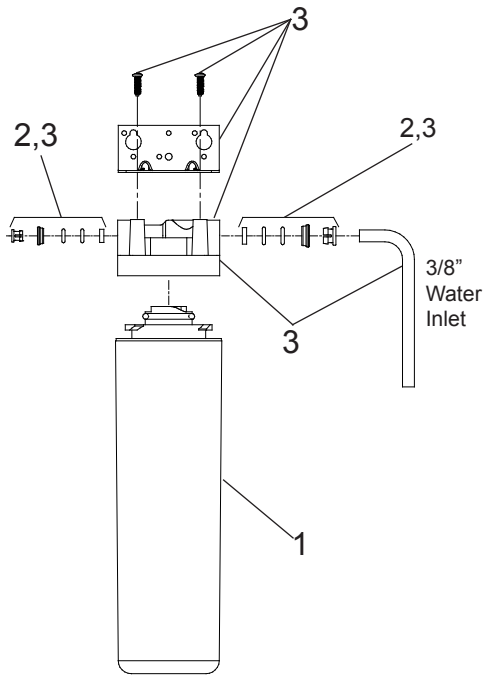

**WATER FILTER EXPLODED VIEW**  
Fig. 8

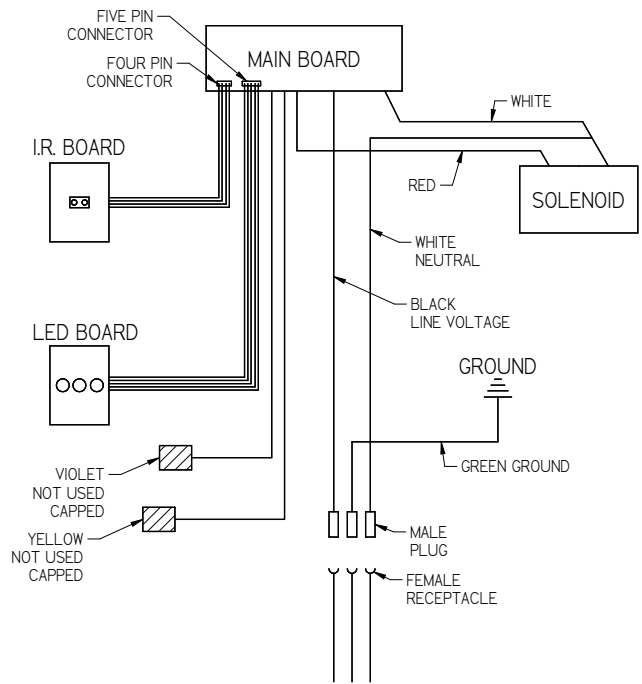

**ELECTRICAL DIAGRAM**  
Fig. 9

REPLACEMENT PART KITS	
PART NO.	DESCRIPTION
98543C	Kit - Electrical Package
98544C	Kit - EE Sensor
98545C	Kit - Solenoid Valve Replacement
98546C	Kit - Aerator Replacement
98549C	Kit - Hardware & Waterway Parts
98631C	Kit - Electrical Package 220V
98632C	Kit - Solenoid Valve Replacement 220V

FOR PARTS, CONTACT YOUR LOCAL DISTRIBUTOR OR CALL 1.800.834.4816  
 PARA PIEZAS, CONTACTE A SU DISTRIBUIDOR LOCAL O LLAME AL 1.800.834.4816  
 POUR OBTENIR DES PIÈCES, CONTACTEZ VOTRE DISTRIBUTEUR LOCAL OU COMPOSEZ LE 1.800.834.4816

REPAIR SERVICE INFORMATION TOLL FREE NUMBER 1.800.260.6640

NÚMERO GRATIS DE SERVICIO 1.800.260.6640  
 INFORMATIONS POUR LE SERVICE PAR NUMERO SANS FRAIS 1.800.260.6640

ELKAY MANUFACTURING COMPANY • 2222 CAMDEN COURT • OAK BROOK, IL 60523 • 630.574.8484 • www.elkay.com

PRINTED IN U.S.A.  
 IMPRESO EN LOS E.E.U.U.  
 IMPRIME AUX E.-U.

# MFWS100 MOUNTING FRAME INSTRUCTIONS

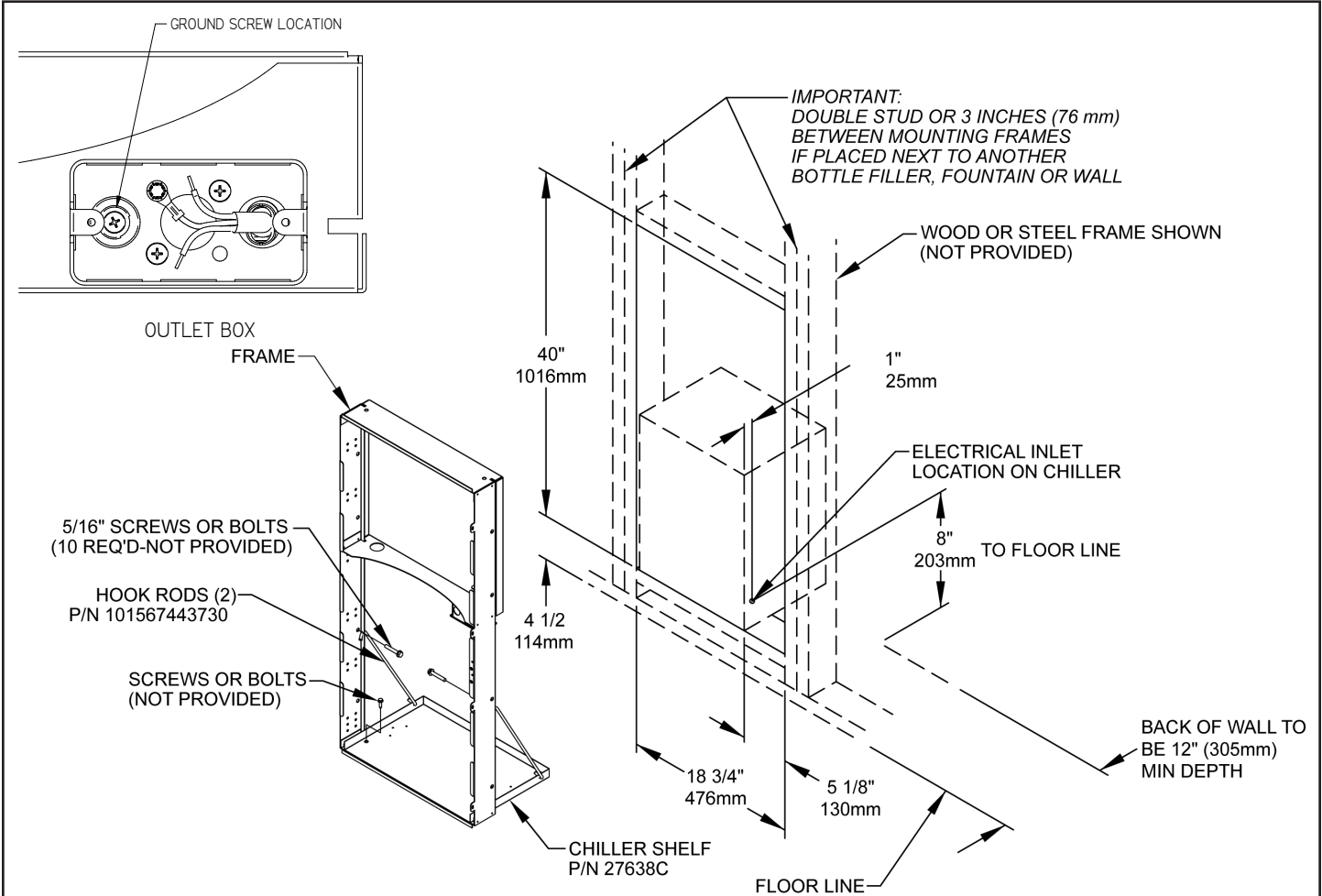

1. Cut a square rectangular wall opening 18 3/4" (476mm) W x 40" (1016mm) H and 4 1/2" (114mm) above the floor line. These dimensions are required to obtain proper rim and bubbler heights for compliance with ANSI standard A117.1.
2. Reinforce the wall opening on all sides so that it will adequately support the water fountain. This reinforcement must support up to 150 lbs static load and provide a means for securing the frame assembly in place.  
**NOTE:** Building construction must allow for adequate air flow on both sides and top of remote chiller unit. Minimum of 4" (102mm) is required.
3. Install plumbing and electrical rough-ins. A junction box for a (3) wire, 10-amp branch circuit is provided on the inside of the chiller. An additional junction box for a (3) wire, 10-amp branch circuit for the Bottle Filler dispenser is included with the mounting frame. (Standard 120 Volts, 60 Hz and single phase for both circuits).
4. Remove frame assembly and related hardware from packaging. Install the frame squarely in wall opening with frame upright edges flush with the finished wall face. Place shelf inside frame and line up the (2) holes on each. Insert loose ends of rods into holes on sides of shelf panel. Using appropriately sized screws or bolts (not provided), fasten the shelf and frame to bottom of wall opening. Secure the frame sides and top to the wall using (10) 5/16" bolts or screws (not provided). Tighten securely.  
**NOTE:** Be sure that frame is squared in location. Do not use less than required screw quantity and size.
5. Mounting Frame Wiring Instructions:
  - a. Turn off electrical supply to installation location circuit.
  - b. Remove Junction Box Cover to gain access to electrical box.
  - c. Connect electrical supply using conduit, wiring, and connectors per local and national codes.
  - d. Connect ground wire to ground screw (provided).
  - e. Connect black wire to "hot" power supply line 120V 60Hz, 1 phase.
  - f. Connect white wire to Neutral line.
  - g. Replace Junction Box Cover.
  - h. Connect electrical power to installation location circuit.

Patent [zurn-elkay.com/patents](http://zurn-elkay.com/patents)

⚠ **WARNING:** Cancer and Reproductive Harm - [www.P65Warnings.ca.gov](http://www.P65Warnings.ca.gov)

⚠ **ADVERTENCIA:** Cáncer y daño reproductivo - [www.P65Warnings.ca.gov](http://www.P65Warnings.ca.gov)

⚠ **AVERTISSEMENT:** Cancer et effets néfastes sur la reproduction - [www.P65Warnings.ca.gov](http://www.P65Warnings.ca.gov)

FOR PARTS, CONTACT YOUR LOCAL DISTRIBUTOR OR CALL 1.800.323.0620

98560C (Rev. F - 04/2023)

# ELKAY® Refrigeration Package

## INSTALLATION, CARE & USE MANUAL

**Note: Danger! Electric shock hazard. Disconnect power before servicing unit.**

USES HFC-134A REFRIGERANT

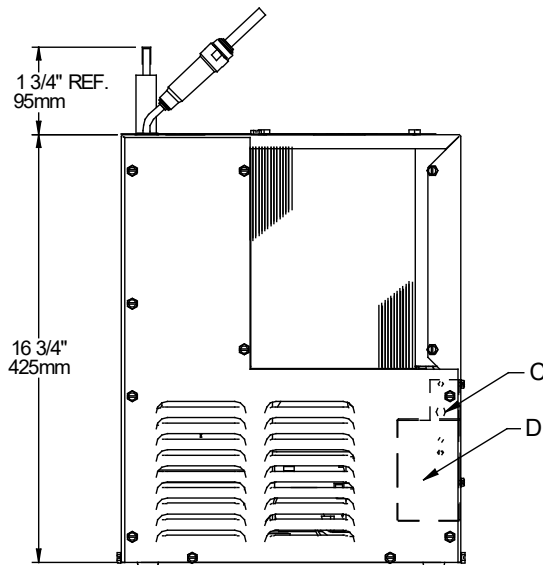
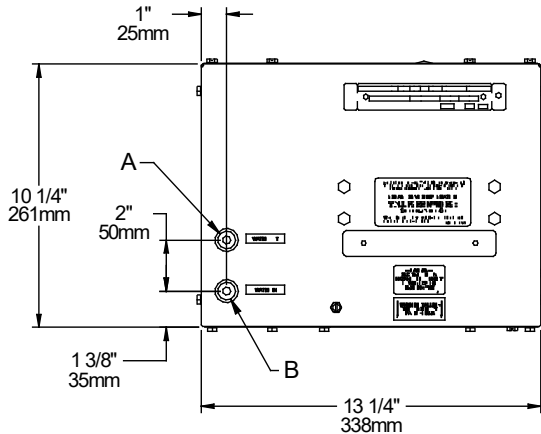

**LEGEND**  
**A = 1/4" O.D. TUBE WATER OUTLET**  
**B = 1/4" O.D. TUBE WATER INLET**  
**C = TEMPERATURE ADJUSTMENT**  
**D = ELECTRICAL**

### INSTALLATION

1. When mounting unit in an open area, to insure proper ventilation, maintain a 4" (102mm) clearance from cabinet louvers on each side of cooler. When mounting unit in a cavity or behind a wall maintain minimum space of 4" (102mm) on each side, 4" (102mm) on the top and a depth of 12" (305mm).
2. Water inlet is 1/4" (6 mm) O.D. tube. Contractor to supply the connections as required.
3. Connecting lines to be of unplated copper, thoroughly flushed to remove all foreign matter before being connected to cooler. If flushing does not remove all particles, a water strainer should be installed in supply line. This cooler is manufactured in such a manner that it does not in any way cause taste, odor, color or sediment problems.
4. Connect cooler to building supply line with a shut-off valve and install the in-line strainer between the valve and cooler.
5. Electrical: Make sure power supply is identical in voltage, cycle, and phase to that specified on cooler serial plate. Never wire compressor directly to the power supply.
6. This chiller has been designed for use with potable water **ONLY**.

### START-UP

1. Open supply line valve.
2. Purge air from all water lines by operating bubbler valve of fountain to which cooler is connected. Steady stream assures all air is removed.
3. Rotate fan to insure proper clearance and free fan action.
4. Connect to electrical power.

### TROUBLE SHOOTING & MAINTENANCE

**Temperature Control:** Factory set at 50°F (± 5°) under normal conditions. For colder water, adjust screw on item no. 9 in clockwise direction.

**Ventilation:** Cabinet louvers and condenser fins should be periodically cleaned with brush, air hose or vacuum cleaner. Excess dirt or poor ventilation can cause no cold water and compressor cycling on the compressor overload protector.

**Lubrication:** Motors are lifetime lubricated.

**Actuation of Quick Connect Water Fittings:** Cooler is provided with lead-free connectors which utilize an o-ring seal. To remove tubing from the fittings, relieve water pressure, push in on gray collar while pulling on the tubing. To insert tubing, push tube straight into fitting until it reaches a positive stop, approximately 3/4".

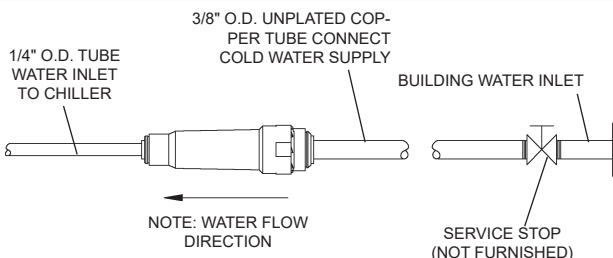

### OPERATION OF QUICK CONNECT FITTINGS

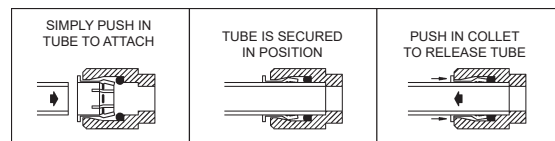

PUSHING TUBE IN BEFORE PULLING IT OUT HELPS TO RELEASE TUBE

Patent [zurn-elkay.com/patents](http://zurn-elkay.com/patents)

⚠ **WARNING:** Cancer and Reproductive Harm - [www.P65Warnings.ca.gov](http://www.P65Warnings.ca.gov)

⚠ **ADVERTENCIA:** Cáncer y daño reproductivo - [www.P65Warnings.ca.gov](http://www.P65Warnings.ca.gov)

⚠ **AVERTISSEMENT:** Cancer et effets néfastes sur la reproduction - [www.P65Warnings.ca.gov](http://www.P65Warnings.ca.gov)

115V ITEMIZED PARTS LIST

ITEM NO.	PART NO.	DESCRIPTION
1	98724C	KIT - EVAP REPLACE ASSY
2	28478C	CABINET
3	98776C	KIT - CONDENSER/DRIER
4	98775C	KIT - FAN MTR/BLADE/NUT/SHROUD
5	20282C	BRACKET - FAN MOUNTING
6	98778C	KIT - HEAT EXCHANGER/DRIER
7	66703C	DRIER
*8	36322C	COMPRESSOR SERVICE PAK
9	98773C	KIT - COLD CONTROL/SCREWS
10	28477C	PANEL - FRONT
11	0000000238	KIT - ELECT/RELAY/COVER/OL
12	98777C	KIT - COMPRESSOR MTG HDWE
13	50930C	BUMPER
14	27303C	BASEPLATE
15	22300C	PANEL - REAR
16	55996C	IN-LINE STRAINER

**\*INCLUDES RELAY & OVERLOAD. IF UNDER WARRANTY, REPLACE WITH SAME COMPRESSOR USED IN ORIGINAL ASSEMBLY.**

NOTE: All correspondence pertaining to any of the above water cooler or orders for repair parts MUST include model number and serial number of cooler, name and part number of replacement part.

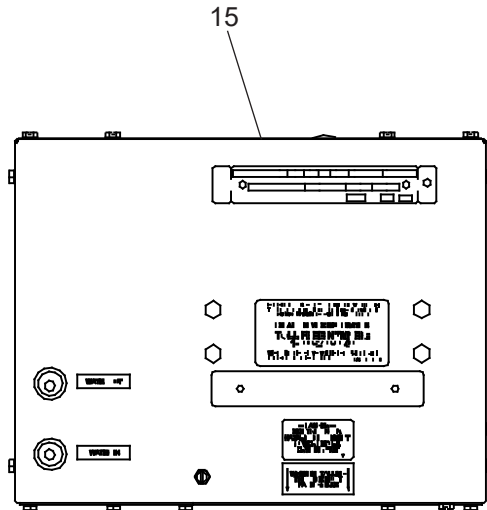

220V - 50/60HZ ITEMIZED PARTS LIST

ITEM NO.	PART NO.	DESCRIPTION
4	0000000244	KIT - FAN MTR/BLADE/NUT/SHROUD (50 HZ)
	0000000245	KIT - FAN MTR/BLADE/NUT/W/O SHRD (60 HZ)
*8	1000002147	COMP. SERVICE PAK (50 HZ)
	1000002146	COMP. SERVICE PAK (60 HZ)
11	98751C	KIT - ELECT/RELAY/COVER/OL (50 HZ)
	98752C	KIT - ELECT/RELAY/COVER/OL (60 HZ)
17	56237C	SHROUD

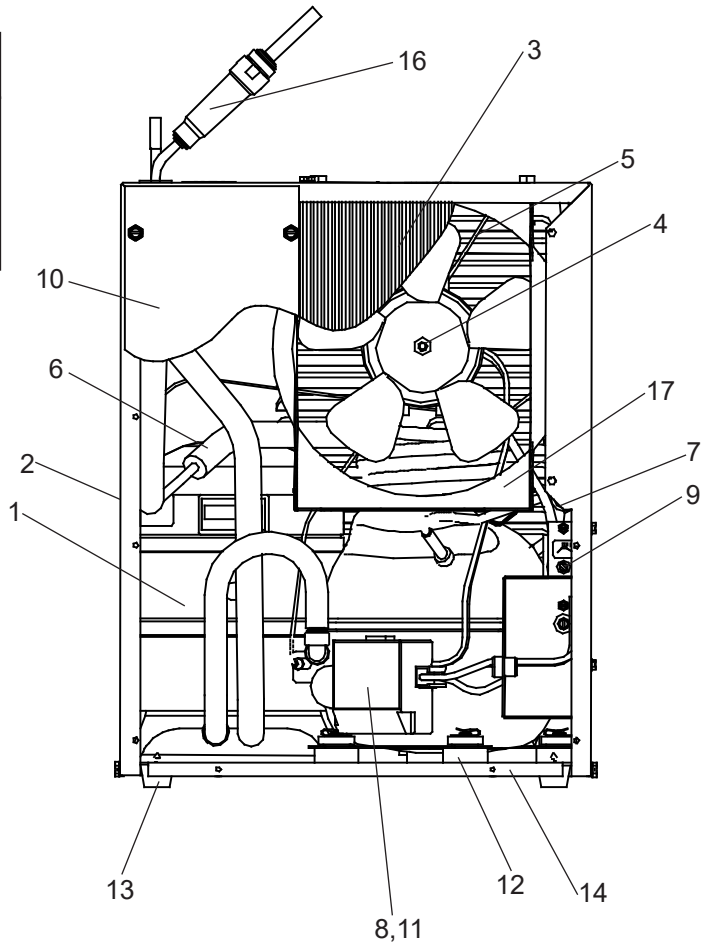

WIRING DIAGRAM

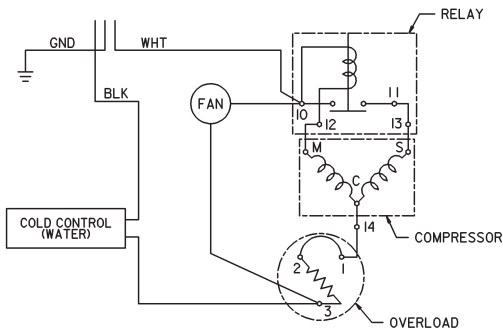

REPAIR SERVICE INFORMATION TOLL FREE NUMBER 1.800.260.6640  
FOR PARTS, CONTACT YOUR LOCAL DISTRIBUTOR OR CALL 1.800.834.4816

PRINTED IN U.S.A.

ELKAY MANUFACTURING COMPANY • 1333 BUTTERFIELD ROAD • DOWNERS GROVE, IL 60515 • 630.574.8484 • www.elkay.com