









Thank you for purchasing this quality product. Be sure to check all packing materials carefully for small parts, which may have come loose inside the carton during shipment. Identify and count all items and compare with the parts list and/or hardware list shown below.

PARTS LIST			
No.	DESCRIPTION	SKETCH	Q'TY
A	TABLE TOP		1
B	TABLE LEGS		4
C	COUPLING		4
D	LINK BOARD		2

HARDWARE LIST			
No.	DESCRIPTION	SKETCH	Q'TY
1	ALLEN BOLT (5/16" x 6")		8
2	ALLEN BOLT (5/16" x 2-1/2")		16
3	SPRING WASHER (5/16")		24
4	FLAT WASHER (5/16" x 0.75" x 0.06")		24
5	ALLEN KEY M5		1

ASSEMBLY INSTRUCTION DINING TABLE

NOTICE:

Link board (D) are attached on the table top (A) in the package.
STEP 1: Before assembling the table, please disassemble and remove the link board (D) from table top (A) and keep all the disassembled bolts from this step for STEP 3 (Dining Table) or STEP 4 (Counter Table).

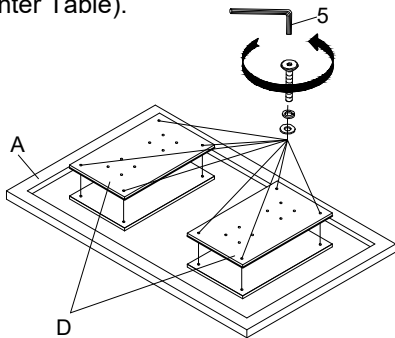

STEP 2: Assembly link board (D) with the table legs (B)

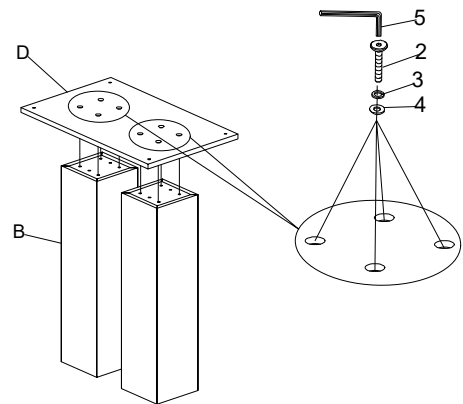

STEP 3: Assembly table legs (B) and link board (D) with the table top (A)

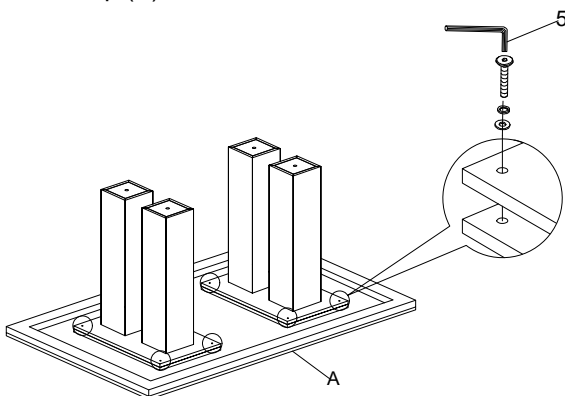

COMPLETED!

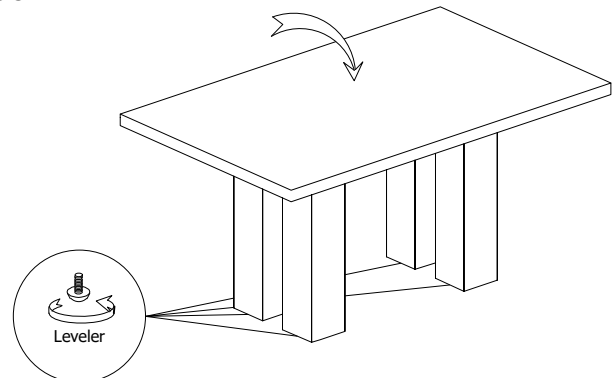

DO NOT TIGHTEN SCREWS UNTIL COMPLETELY ASSEMBLED !

ASSEMBLY INSTRUCTION COUNTER TABLE

NOTICE:

Link board (D) are attached on the table top (A) in the package.
STEP 1: Before assembling the table, please disassemble and remove the link board (D) from table top (A) and keep all the disassembled bolts from this step for STEP 3 (Dining Table) or STEP 4 (Counter Table).

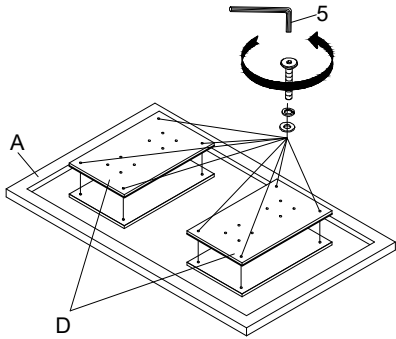

STEP : 2

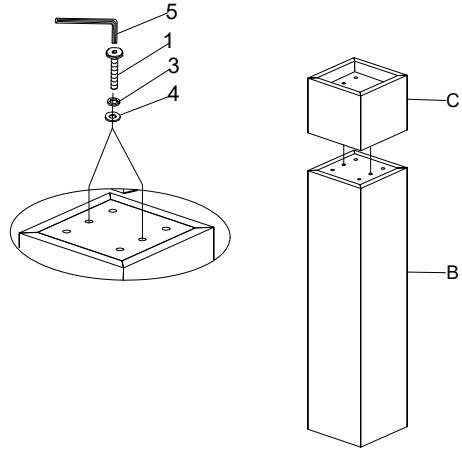

STEP 3: Assembly link board (D) with the table legs (B)

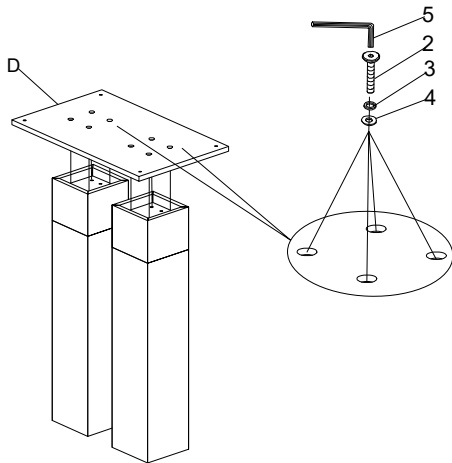

STEP 4: Assembly table legs (B) and link board (D) with the table top (A)

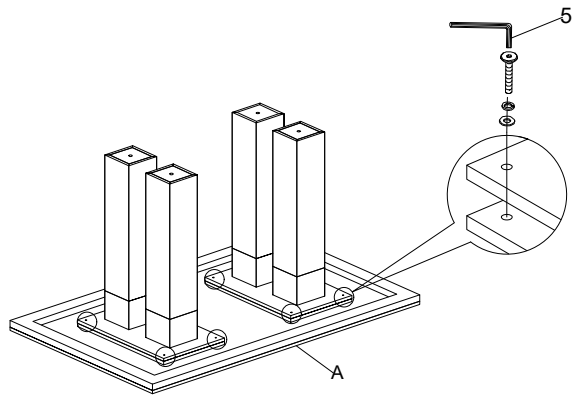

COMPLETED !

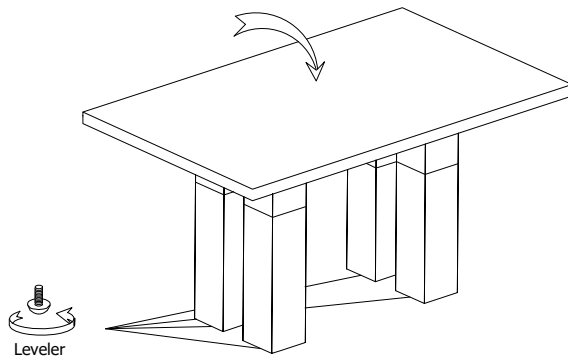

DO NOT TIGHTEN SCREWS UNTIL COMPLETELY ASSEMBLED !