

SKU# 64100-01

MOUNTING AND CLEANING INSTRUCTIONS

DESK MOUNTING

Four mounting holes are located on the back of the unit located 16" C/C and should be aligned with wall studs for hanging.

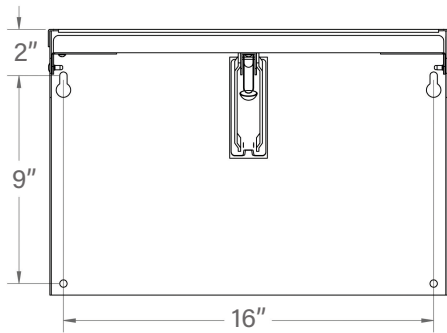

Secure two ¼" lag bolts or screws (hardware not provided) through upper keyholes of back plate.

Hang desk and tighten bolts. Using two more ¼" lag bolts or screws, secure back plate to wall studs through lower holes, also 16" C/C.

Due to the various types of wall construction, hardware to be used and method of installation should be approved by an appropriate engineering, architectural or construction professional to ensure that all anchoring hardware will support the required loads.

OPERATION

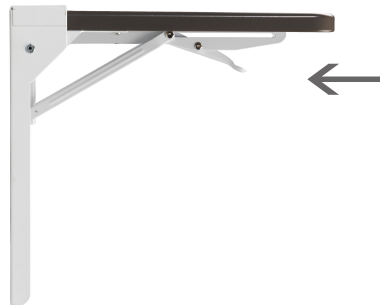

To Raise Work Surface:

Lift work surface until handle locks into place.

Caution: Pinch Warning - Do not hold work surface directly under handle while lifting.

To Lower Work Surface:

Lift work surface up slightly, squeeze trigger, then lower work surface.

CARE/CLEANING

The recommended method of cleaning is using a solution of warm water and mild detergent. Use a soft cloth or sponge and a liberal quantity of water. To scrape something off, use a plastic scraper only. Other acceptable cleaners include Fabuloso®, Goo Gone® or an equivalent orange cleaner and 10% bleach to water solution. In no circumstances, should any abrasive cleaner or any cleaner containing ketones, esters, or alcohols be used.

To assure smooth operation of the locking handle, lubricate the four hinge pins with a silicone lubricant regularly as needed.