



Project Name: _____

Location: _____

Item #: _____

Qty: _____

Adcraft Nacho Chip Warmer/Merchandiser, in Stainless Steel

NCM530W



Keep your tortilla chips warm, crispy, and ready to serve while boosting sales with the Adcraft Nacho Chip Warmer/Merchandiser. This commercial nacho chip warmer and merchandiser is perfect for Mexican restaurants, concession stands, movie theaters, food trucks, and catering events. This versatile unit not only maintains ideal chip temperature but also showcases your product in an attractive display that draws customers in. Built from durable stainless steel, this heated nacho chip dispenser combines performance, convenience, and presentation.

Features and Construction

- Durable stainless steel construction for reliable performance
- Operates on 120V with a NEMA 5-15 plug type
- Keeps tortilla chips warm, fresh, and ready for serving
- 2.9 cu ft capacity stores and warms tortilla chips
- Features no casters for stable placement
- Drop-down door for easy access
- Features manual control for precise operation
- Maintains a temperature range of 75° to 155°F
- Combines warming and merchandising to enhance both service and sales
- Includes a convenient serving scoop for quick and mess-free portioning of chips

Electric

120V ~ 60Hz - 530W (4.30)A
Cord Length (Inches): 59
Plug Type: NEMA 5-15P
Cord set included

NEMA 5-15P



3rd Party Approvals



Warranty (USA / Canada)

Protected by Admiral Craft Equipment Corporation's One-Year Limited Warranty

Contact Admiral Craft Equipment for details at 1-877-672-7740



Temperature

- Temperature Range (Fahrenheit): 75 - 155°F
- Ambient Temperature Range (Fahrenheit): 40-104°F

Included Components

- Scoop, 9W LED bulb



Adcraft Nacho Chip Warmer/Merchandiser, in Stainless Steel

NCM530W

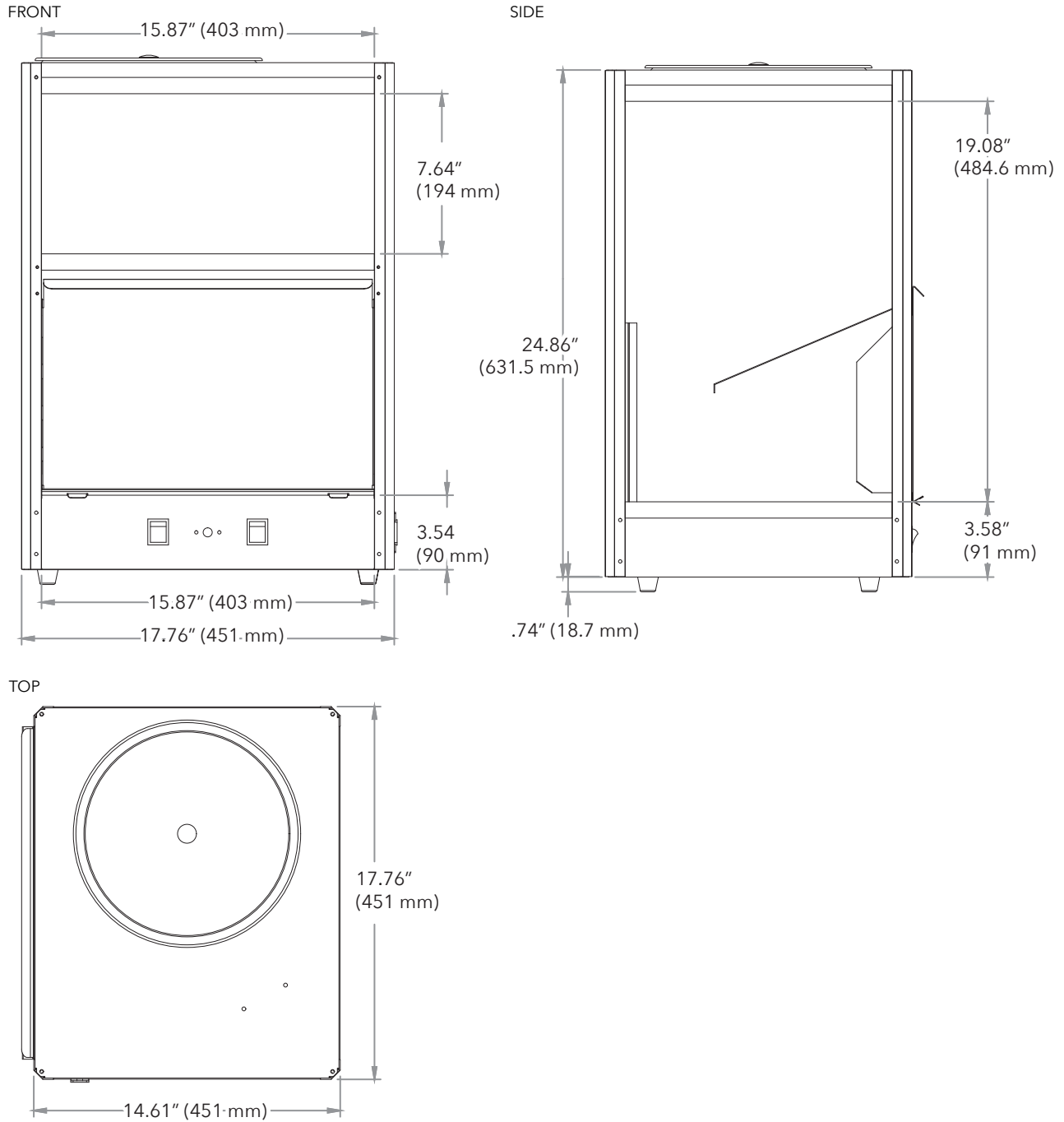

Countertop

Control Type	Capacity	Interior Dimensions L x W x H (in)	Assembled Dimensions L x W x H (in)	Package Dimensions L x W x H (in)	Item Weight (lb)	Shipping Weight (lb)
Manual	2.90 cu. ft.	14.50 x 17.00 x 20.50	14.61" x 17.76" x 24.86"	22.00" x 18.50" x 28.40"	30.5	36.6

Due to periodic changes in designs, methods, procedures, policies and regulations, the specifications contained in this document are subject to change without notice. While we exercise good faith efforts to provide information that is accurate, we are not responsible for errors or omissions in information provided or conclusions reached as a result of using the specifications. By using the information provided, the user assumes all risks in connection with such use.