

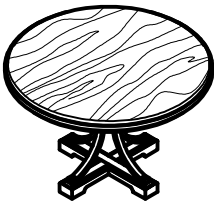











HEKMAN®

X A HOWARD MILLER COMPANY

24819 ROUND DINING TABLE

HARDWARE LIST						
A	B	C	D	E	F	
ALLEN BOLT M6 X 30 (8 PCS.)	ALLEN BOLT M6 X 40 (4 PCS.)	ALLEN BOLT M6 X 70 (4 PCS.)	FLAT W. M6 16 PCS.	SPRING W. M6 16 PCS.	ALLEN KEY L4 (FOR ALLEN BOLT) 1 PC.	
						

PART INSIDE				
1	2	3	4	5
TOP PANEL (1 Pc)	WOOD LEG (1 Pc)	METAL STREACHER (1 Pc)	METAL LEG X (1 Pc)	METAL LEG Y (2 Pcs)
				

Assembly Instruction

STEP 1.

PLACE ROUND DINING TABLE BODY IN A SOFT, AND FLAT SURFACE. ASSEMBLE THE METAL LEG Y (5) TO THE HOLE IN THE RING METAL LEG X (4) USING THE PROVIDED ALLEN BOLT (A), SPRING WASHER (E), FLAT WASHER (D) AND ALLEN KEY (F).

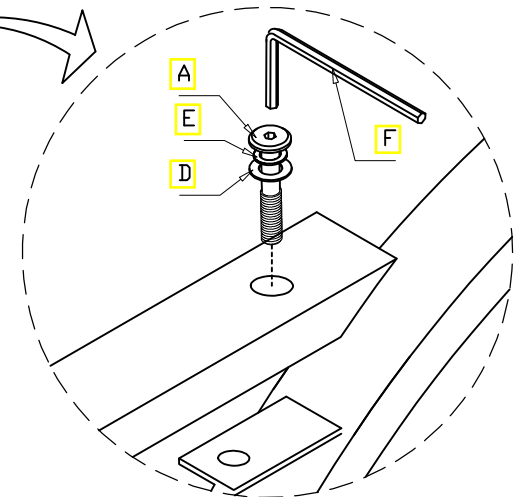
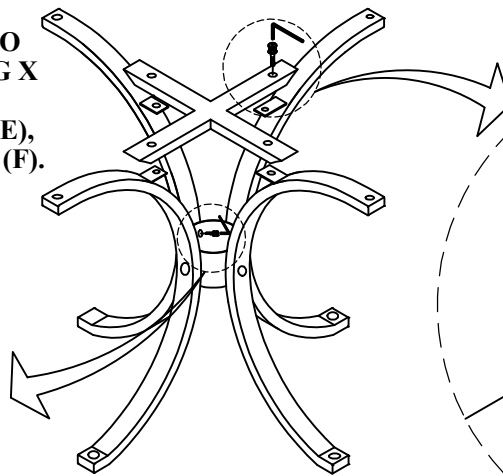
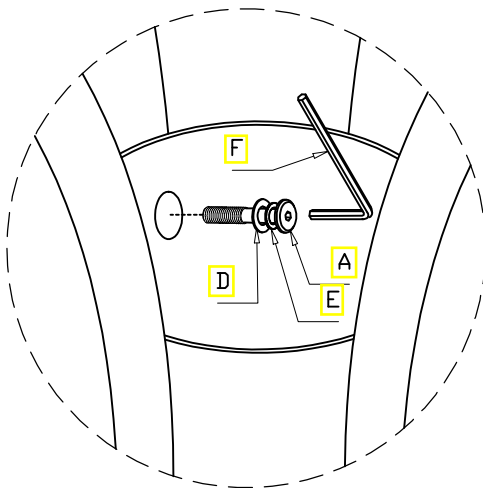

STEP 2.

INSTALL METAL STREACHER (3) TO THE PLATE ON THE METAL LEG X (4) AND METAL LEG Y (5) USING THE PROVIDED ALLEN BOLT (A), SPRING WASHER (E), FLAT WASHER (D) AND ALLEN KEY (F).

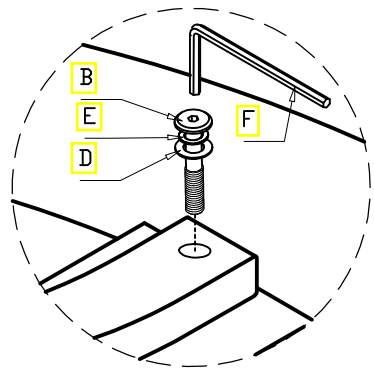
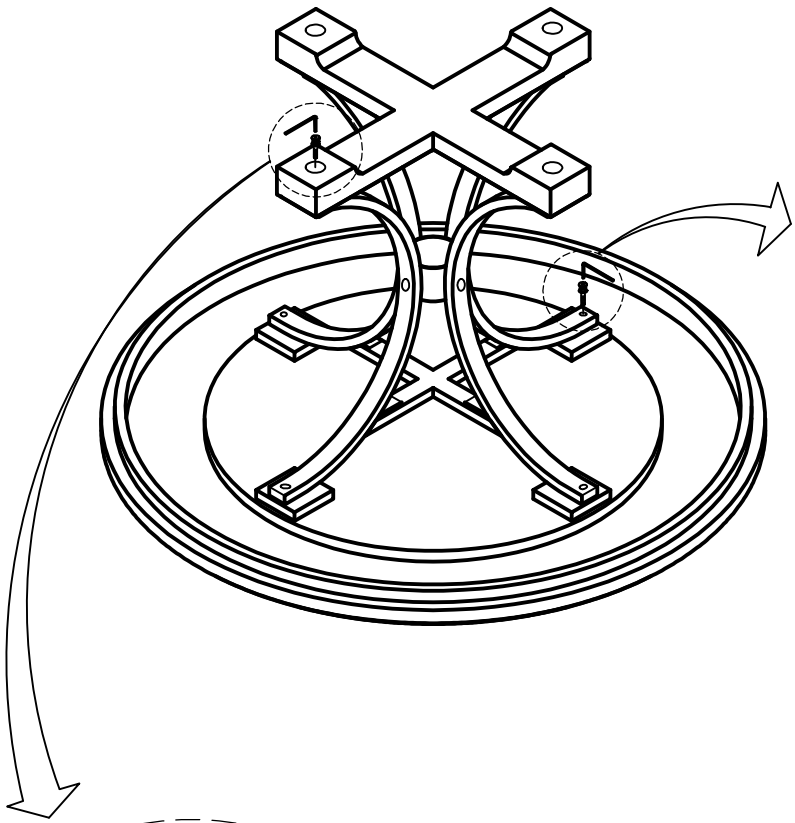

STEP 3.

INSTALL METAL LEG X (4) AND METAL LEG Y (5) TO THE HOLE WHICH UNDER THE TOP PANEL (1) USING THE PROVIDED ALLEN BOLT (B), SPRING WASHER (E), FLAT WASHER (D) AND ALLEN KEY (F).

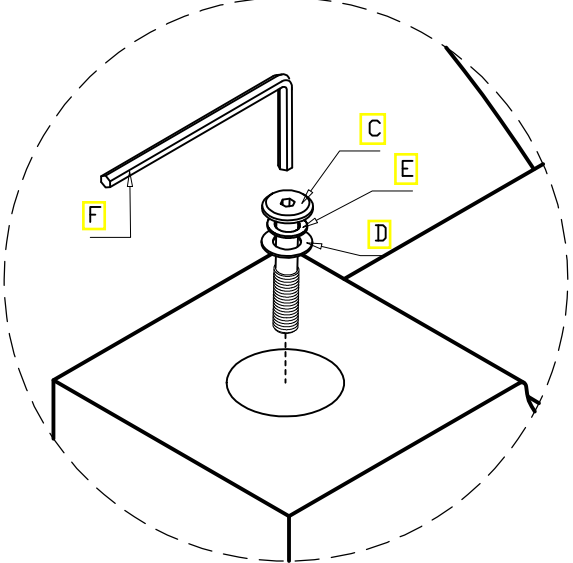

STEP 4.

INSTALL WOOD LEG (2) TO THE HOLE IN THE METAL LEG X (4) AND METAL LEG Y (5) USING THE PROVIDED ALLEN BOLT (C), SPRING WASHER (E), FLAT WASHER (D) AND ALLEN KEY (F).

TIGHTEN ALL.