

BLACK DIAMOND®

Project Name: _____

Location: _____

Item #: _____

Qty: _____

Black Diamond 10 Qt Planetary Mixer, 3-Speed, 0.75 HP, 120V, in Gray

BDPM-10



The Black Diamond 10 Quart Planetary Mixer is a versatile piece of equipment ideal for commercial kitchens, bakeries, restaurants, and cafes. Use it for blending batters, whipping cream, making mashed potatoes, preparing dough, and creating large batches of sauces. Its heavy-duty construction withstands the rigors of busy commercial use. Features a stainless steel wire safety guard around the 10-quart bowl and stainless steel bowl clamps for secure mixing.

FEATURES AND CONSTRUCTION

- Heavy-duty construction withstands demands of commercial kitchens
- 10 qt stainless steel mixing bowl with wire safety guard
- Stainless steel bowl clamps hold mixing bowl securely
- Rubber inserts on feet for stability
- Direct-drive, 100% gear-driven transmission for consistent mixing speed
- Three fixed mixing speeds with easy shifting
- Push-button on/off switch
- Includes wire whisk, dough hook, and flat beater attachments
- 600W motor powers demanding mixing tasks
- 3/4 HP supplies robust and reliable performance in a compact form

ELECTRIC

120V / 60Hz / 1 ph
Cord Length (Inches): 60"
Plug Type: NEMA 5-15P
Cord set included

NEMA 5-15P



3RD PARTY APPROVALS



Intertek



Intertek

WARRANTY (USA / CANADA)

Protected by Admiral Craft Equipment Corporation's one-year limited warranty.

Contact Admiral Craft Equipment for details at 1-877-672-7740



CAPACITY

- 10 qt

INCLUDED COMPONENTS

- Hook, Flat Beater, Wire Whip

FRONT

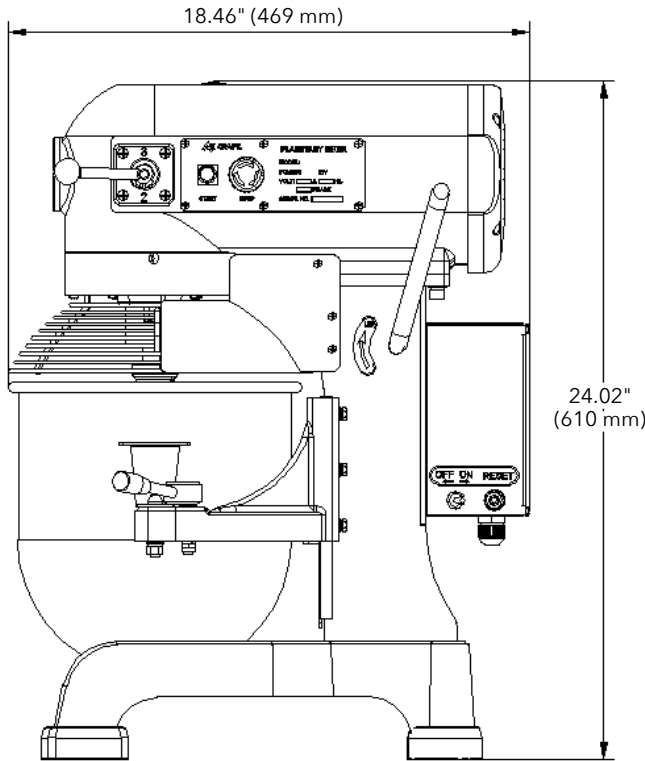

TOP

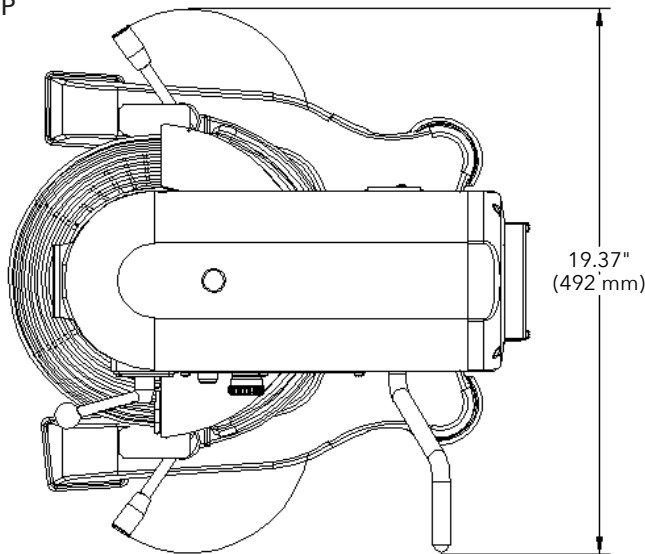

MIXER CAPACITY CHART

Product	Agitator	Speed	Max Bowl Capacity
Bread and roll dough - 60% AR	Dough hook	1st only	12 lbs
Heavy bread dough - 55% AR	Dough hook	1st only	* NR
Pasta Basic Egg Noodle (Max, mix time = 5 min)	Dough hook	1st only	* NR
Pizza dough, thin - 40% AR (Max, mix time = 5 min)	Dough hook	1st only	* NR
Pizza dough, medium - 50% AR	Dough hook	1st only	* NR
Pizza dough, thick - 60% AR	Dough hook	1st only	* NR
Raised donut dough - 65% AR	Dough hook	1st and 2nd	*NR
Whole wheat dough - 70% AR	Dough hook	1st only	*NR
Mashed potatoes	Flat beater	2nd	9 lbs
Mayonnaise (Quarts of Oil)	Flat beater	2nd	4 qts
Waffle or pancake batter	Flat beater	2nd	4 qts
Egg whites	Wire whip	3rd	1 pt
Meringue (Qty. of water)	Wire whip	3rd	3/4 pt
Whipped cream	Wire whip	3rd	2 qts
Cake, Angel Food (8-10 oz. cake)	Wire whip	2nd	6 lbs
Cake, Box or Slab	Flat beater	2nd	11 lbs
Cake, Cup	Flat beater	2nd	11 lbs
Cake, Layer	Flat beater	2nd	11 lbs
Cake, Pound	Flat beater	2nd	11 lbs
Cake Short (Sponge)	Wire whip	3rd	7 lbs
Cake Sponge	Wire whip	3rd	5.5 lbs
Cookies, Sugar	Flat beater	2nd	9 lbs
Pie dough	Flat beater	2nd	10 lbs
Eggs & Sugar for Sponge Cake	Flat beater	2nd	4 lbs
Icing, Fondant	Flat beater	2nd	6 lbs
Icing, Marshmallow	Wire whip	2nd	1 lbs
Shorting & Sugar, Creamed	Flat beater	2nd	8.5 lbs

%AR (% Absorption Ratio) = Water weight divided by flour weight.

The capacities listed in the chart above are based on flour at room temperature and 70°F water temperature.

*NR = Not Recommended

Planetary

Speeds	RPMs	Capacity	Amps	HP	Wattage	Assembled Dimensions (in)	Item Weight (lbs)	Shipping Weight (lbs)
3	113/184/341	10 qt / 9.46 L	6.8	3/4	600W	18.50" x 19.40" x 24.00"	126.0	157.0

Due to periodic changes in designs, methods, procedures, policies and regulations, the specifications contained in this document are subject to change without notice. While we exercise good faith efforts to provide information that is accurate, we are not responsible for errors or omissions in information provided or conclusions reached as a result of using the specifications. By using the information provided, the user assumes all risks in connection with such use.