

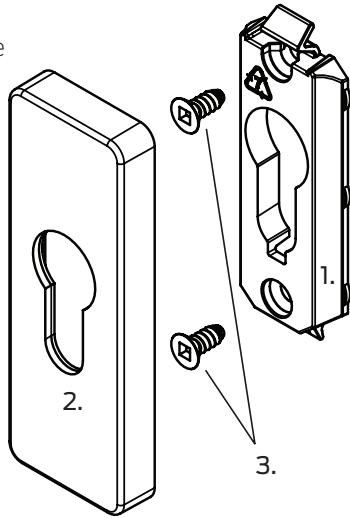

Verta Slim Euro Cylinder Escutcheon Installation Instructions

Contents

1. 1 x Escutcheon base
2. 1 x Escutcheon cap
3. 2 x Fixing screws



Step 1: Door Preparation

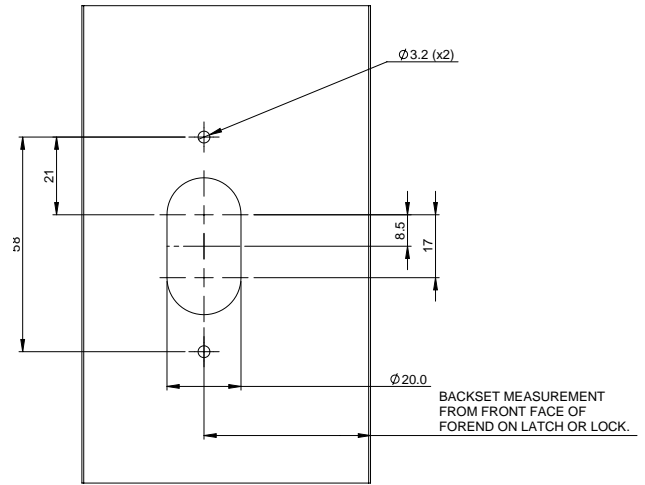

Step 2: Base Fitment

- 2.1 Fit the escutcheon base using 2x fixing screws provided

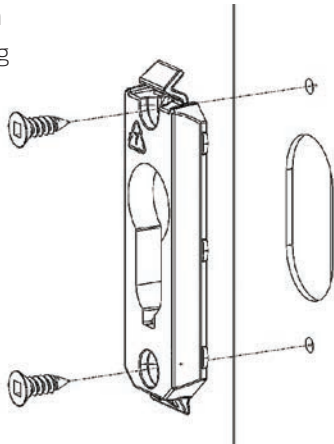

Step 3: Escutcheon Fitment

- 3.1 Mount escutcheon on to the base at the bottom

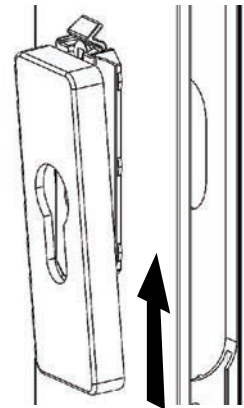

Step 4: Escutcheon Fitment Continued

- 4.1 Press fit the escutcheon on to the base top snap clip

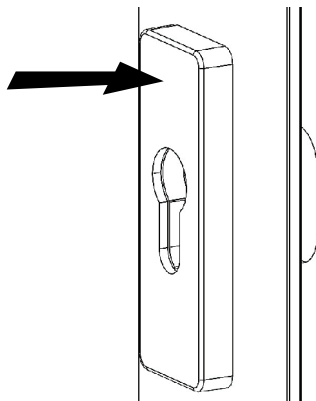

Step 5: Escutcheon Fitment Continued

- 5.1 Escutcheon mounted cross section

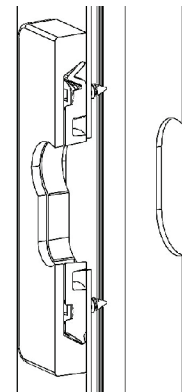

Step 6: Escutcheon Removal

- 6.1 Use a screw driver to push the escutcheon down to release it from the bottom of the base

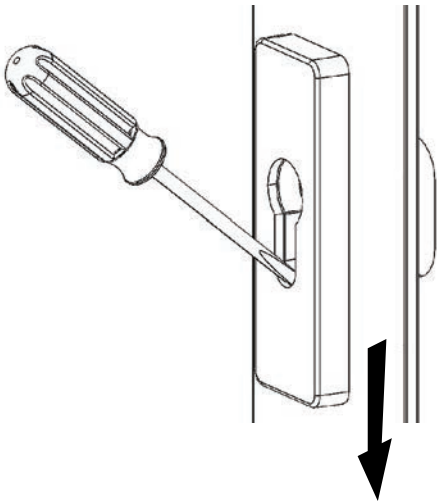

Step 7: Escutcheon Removal

- 6.1 Once released, pull the escutcheon away from the door

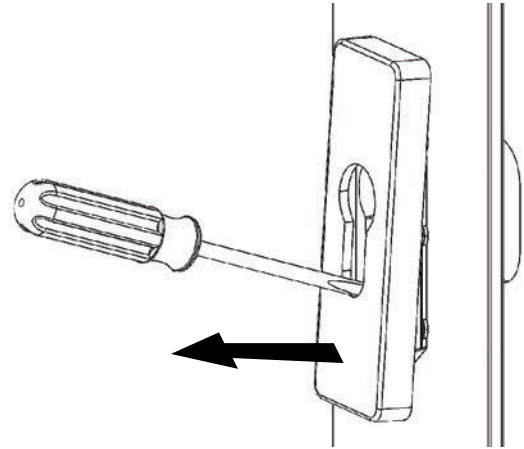

Step 8: Escutcheon Removal

- 6.1 Remove the escutcheon

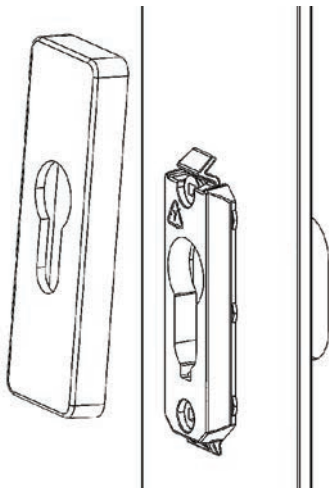

Installed Product

