

Assembly Instructions







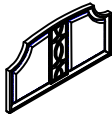
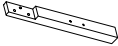

B4627-110 REFLECTIONS 6/6-6/0 EK/WK HEADBOARD
 B4627-120 REFLECTIONS 6/6-6/0 EK/WK FOOTBOARD & SLATS
 B4627-330 REFLECTIONS 5/0-6/6 Q/EK PANEL SIDE RAILS

Thank you for purchasing this quality product. Be sure to check all packing materials carefully for small parts, which may have come loose inside the carton during shipment. Identify and count all items and compare with the PARTS LIST and/or HARDWARE LIST shown below.









CAUTION: Please read the instructions thoroughly before assembly.

1. We recommend that you assemble this product with the assistance of another person; this will make the assembly easier, and will help eliminate damage to the product or injury to persons during assembly.
2. Please do not over tighten screws or bolts until the assembly is completed.
3. Please put all parts on a non-abrasive floor before assembly, and follow the assembly steps to assemble your newly purchased product correctly and efficiently.

PARTS LIST

NO	COMPONENT	DRAWING	Q'TY
A	HEADBOARD		1PC
B	LEFT SIDE FACING (LSF) HEADBOARD LEG		1PC
C	RIGHT SIDE FACING (RSF) HEADBOARD LEG		1PC
D	HEADBOARD CROSSBAR		1PC
E	FOOTBOARD		1PC
F	FOOTBOARD LEG		2PCS
G	SIDE RAIL		2PCS
H	SLAT		5PCS
I	SLAT SUPPORT LEG		10PCS

HARDWARE LIST

NO	COMPONENT	DRAWING	Q'TY
1	BOLT Ø5/16"x2"L		10PCS
2	LOCK WASHER Ø5/16"		10PCS
3	FLAT WASHER Ø5/16"		10PCS
4	ALLEN KEY 1/6"		1PC
5	THREADED BOLT Ø5/16"x3-1/2"L		8PCS
6	HALF MOON WASHER		8PCS
7	HEX NUT Ø5/16"		8PCS
8	WRENCH 1/2"		1PC
9	WOOD SCREW Ø8x1-1/4"L		10PCS

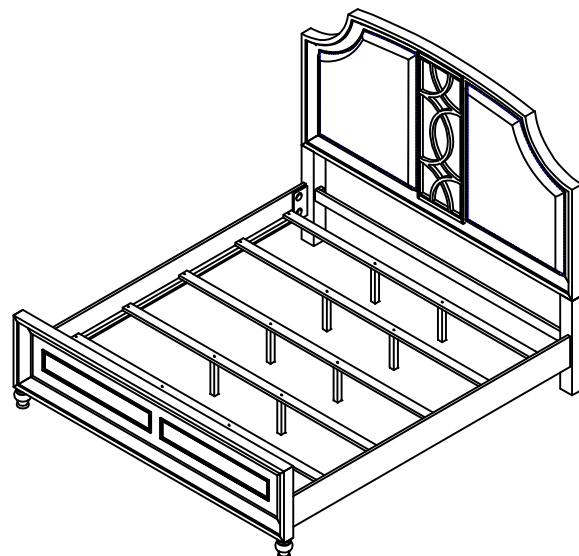

Assembly Instructions

B4627-110 REFLECTIONS 6/6-6/0 EK/WK HEADBOARD
 B4627-120 REFLECTIONS 6/6-6/0 EK/WK FOOTBOARD & SLATS
 B4627-330 REFLECTIONS 5/0-6/6 Q/EK PANEL SIDE RAILS

STEP 1

Assemble LSF HB Leg (B) and RSF HB Leg (C) to Headboard (A) by using Allen Key (4) with hardware 1,2, and 3.

Attn: DO NOT TIGHEN THE BOLTS

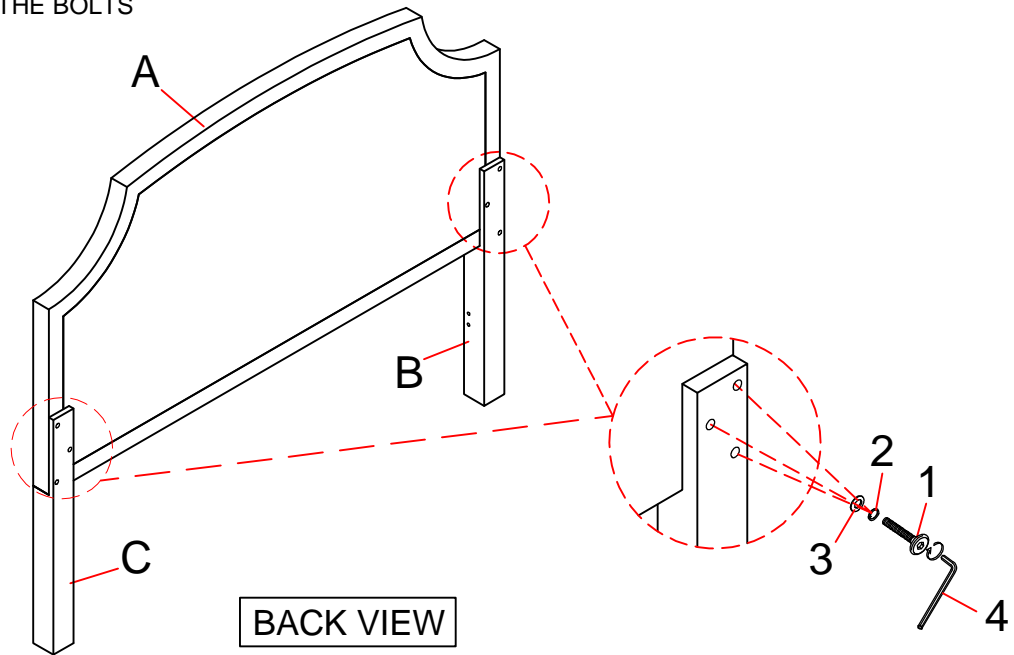

STEP 2

Assemble Headboard Crossbar (D) to Headboard Legs (B) and (C) by using Allen Key (4) with hardware 1,2, and 3.

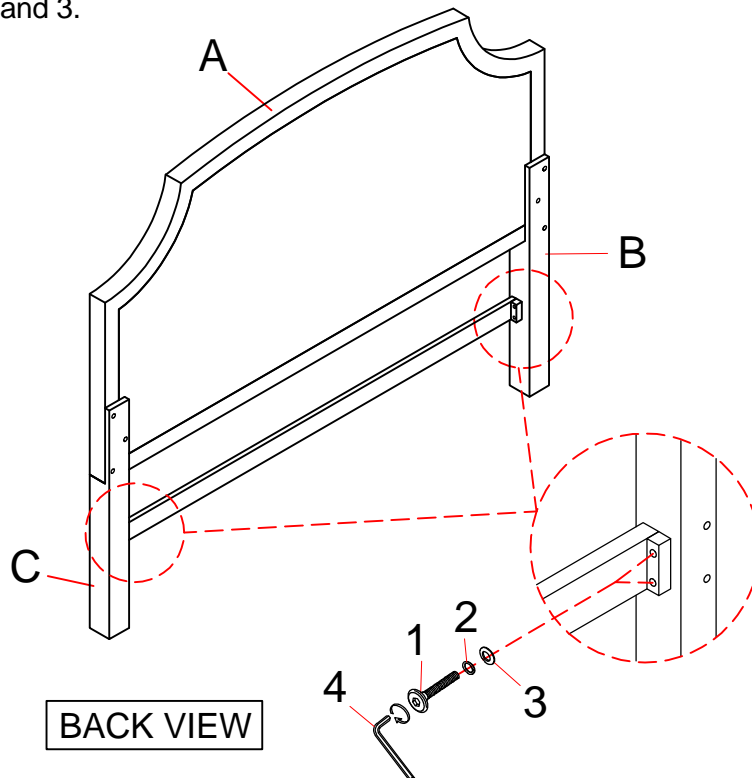

Assembly Instructions

B4627-110 REFLECTIONS 6/6-6/0 EK/WK HEADBOARD
 B4627-120 REFLECTIONS 6/6-6/0 EK/WK FOOTBOARD & SLATS
 B4627-330 REFLECTIONS 5/0-6/6 Q/EK PANEL SIDE RAILS

STEP 3

Assemble the Footboard Legs (F) to the Footboard (E).

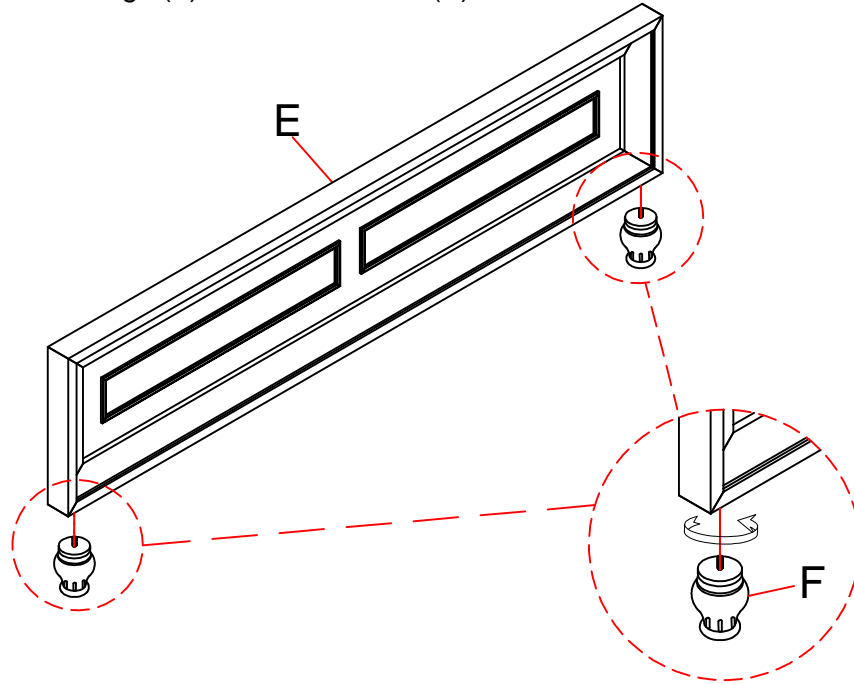

STEP 4

Assemble side rails (G) to Headboard Legs (B & C) and Footboard (E) by using Wrench (8) with hardware 6,7,8.

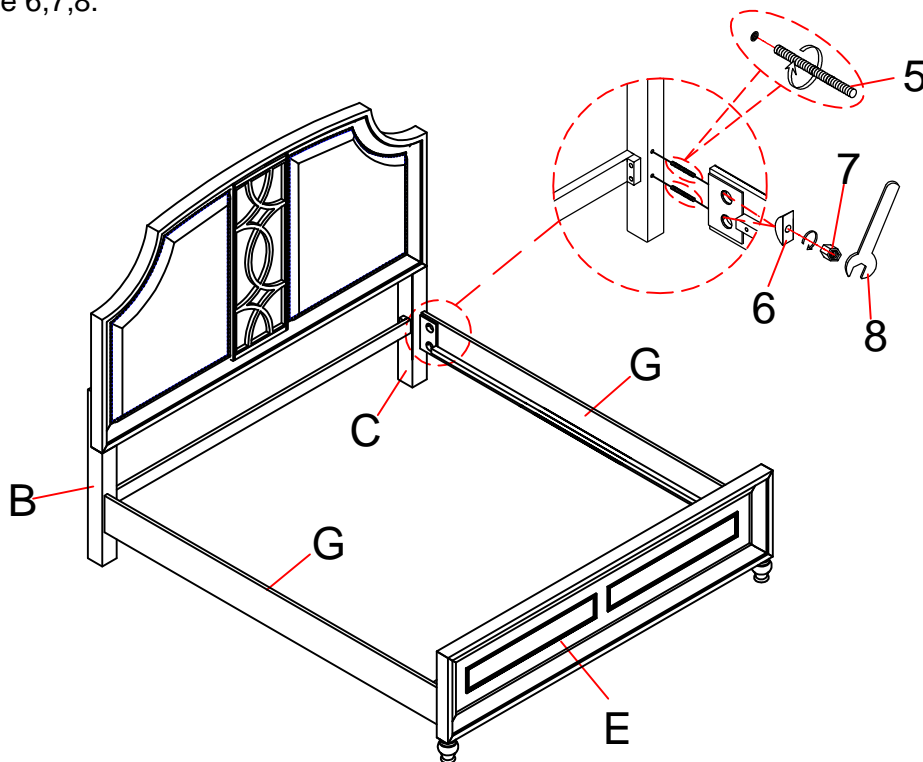

Assembly Instructions

B4627-110 REFLECTIONS 6/6-6/0 EK/WK HEADBOARD
B4627-120 REFLECTIONS 6/6-6/0 EK/WK FOOTBOARD & SLATS
B4627-330 REFLECTIONS 5/0-6/6 Q/EK PANEL SIDE RAILS

STEP 5

Assemble the Slat Support Legs (I) to the Slats (H). Then adjust the leveler on the Slat Support Legs(I) to level with the floor.

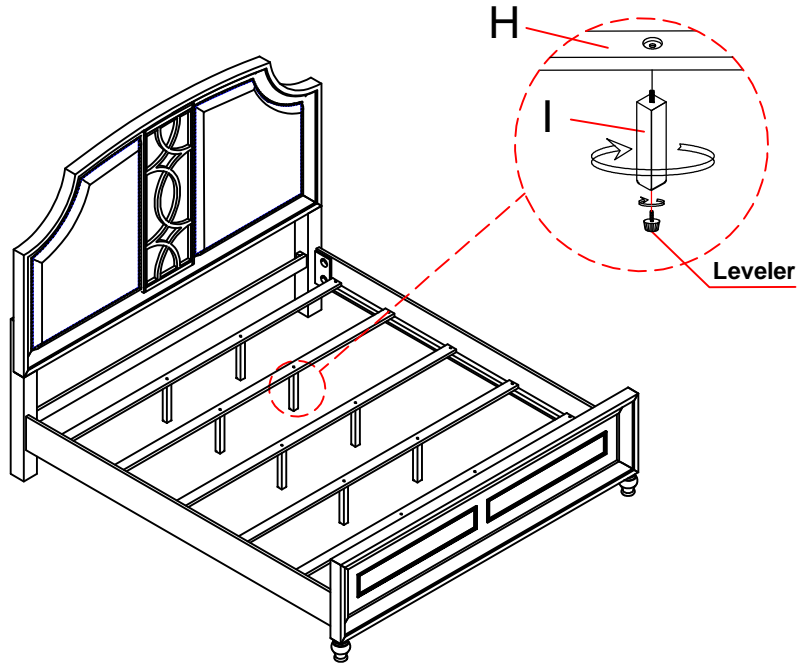

STEP 6

Assemble the Slats (H) to the Side Rails (G) by using a screwdriver with hardware 9.

