

ASSEMBLY INSTRUCTION

2 SIDE DROP LEAF ROUND COUNTER HEIGHT TABLE

A TABLE TOP WITH
LEAF

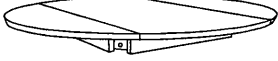

1 PC

E JCBC BOLT
M6 x 65MM

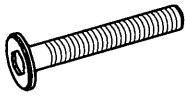

16 PCS

B LEG

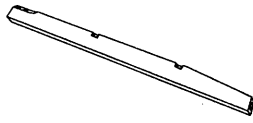

4 PCS

F SPRING WASHER
M6



16 PCS

C SHELF

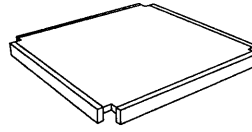

2 PCS

G FLAT WASHER
M6



16 PCS

D ALLEN WRENCH
M4 x 100MM

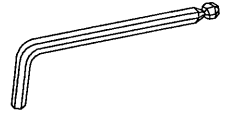

1 PC

H LEVELER
M6 x 23MM



4 PCS

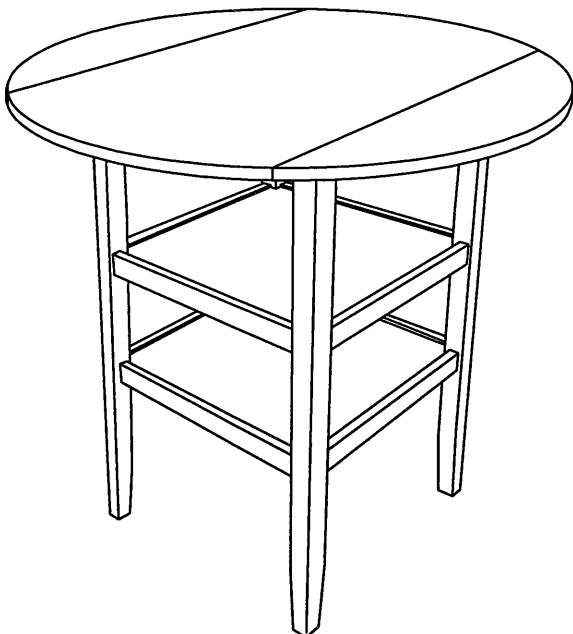

This page lists all the contents included in the box. Please take the time to identify the hardware as well as the individual components to this product. As you unpack and prepare for assembly, place the contents on a carpet or padded area to protect them from damage.

1 Attach Shelf (C) (follow Arrow sticker direction as below) to Leg (B) using JCBC Bolt (E), Spring Washer (F) and Flat Washer (G) and tighten with Allen Wrench (D).

**** Do not fully tighten all the bolts at this step. (Fully tighten the bolt after step 3)**

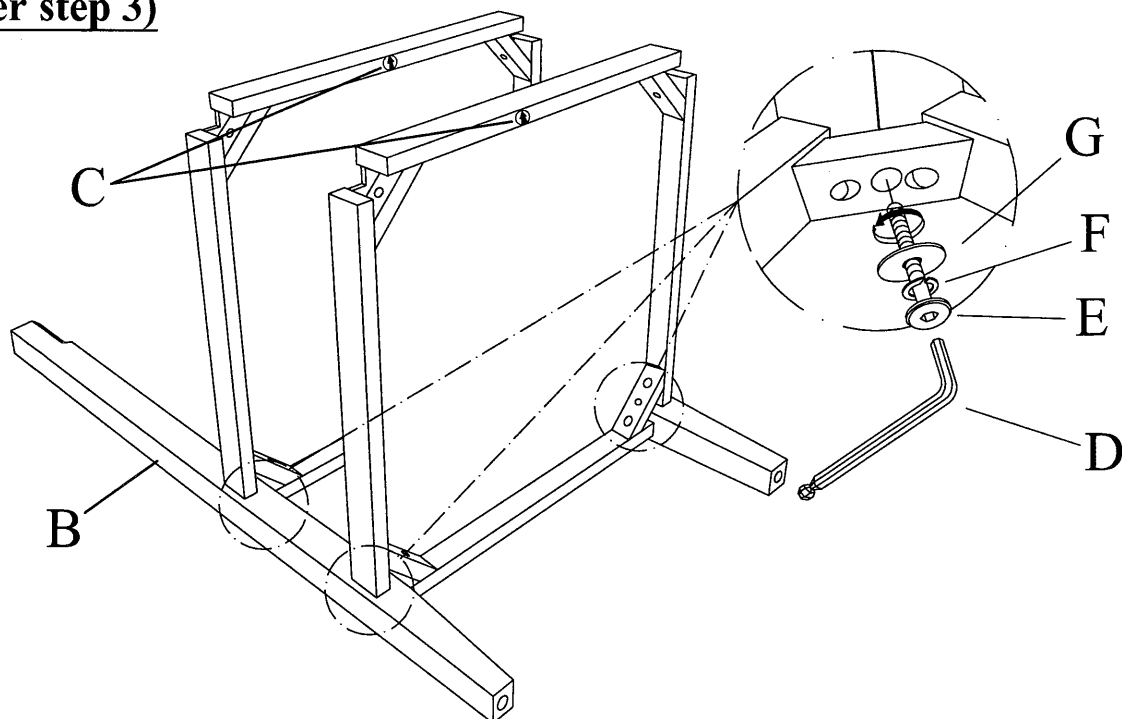

2 Attach the other Leg (B) to Shelf (C) using JCBC Bolt (E), Spring Washer (F) and Flat Washer (G).

**** Do not fully tighten all the bolts at this step. (Fully tighten the bolt after step 3)**

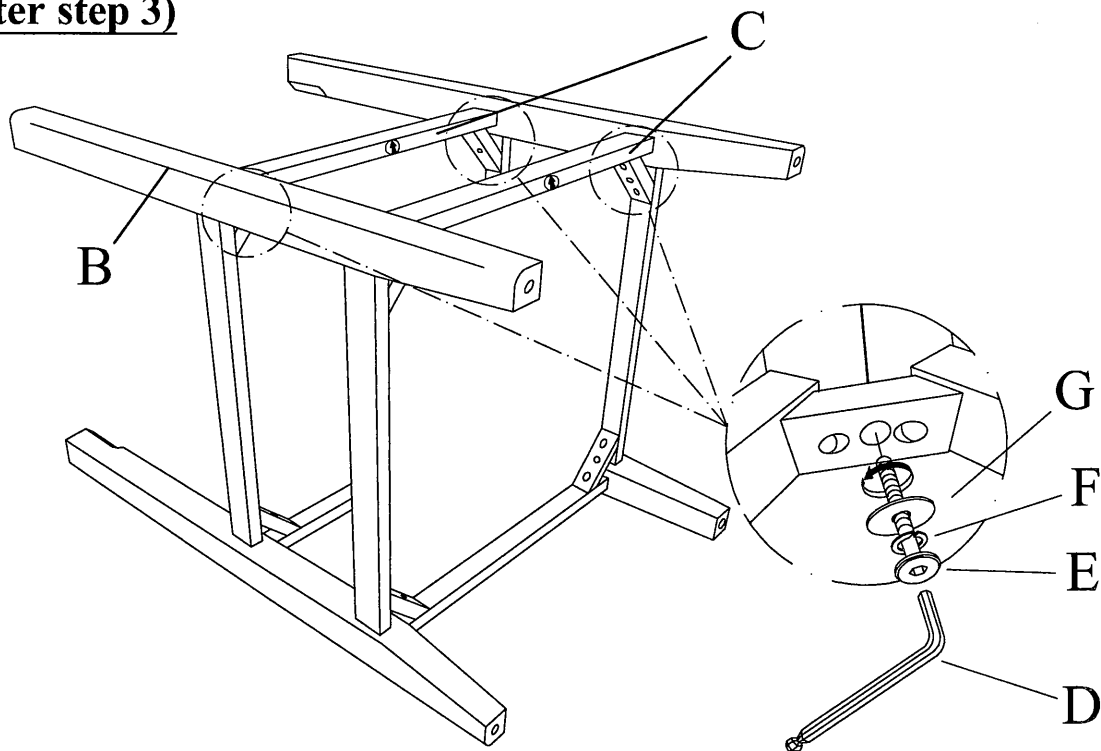

3 (i) Place Table Top (A) upside down on soft surface. Align and fasten Legs (B) to Table Top (A) (follow Arrow Sticker direction as show below) using JCBC Bolt (E), Spring Washer (F) and Flat Washer (G) and tighten with Allen Wrench (D).

(ii) Screw in the Leveler (H) to bottom of Legs (B).

**** Fully tighten all the bolts at this step. (Included all bolts at step 2 and 3)**

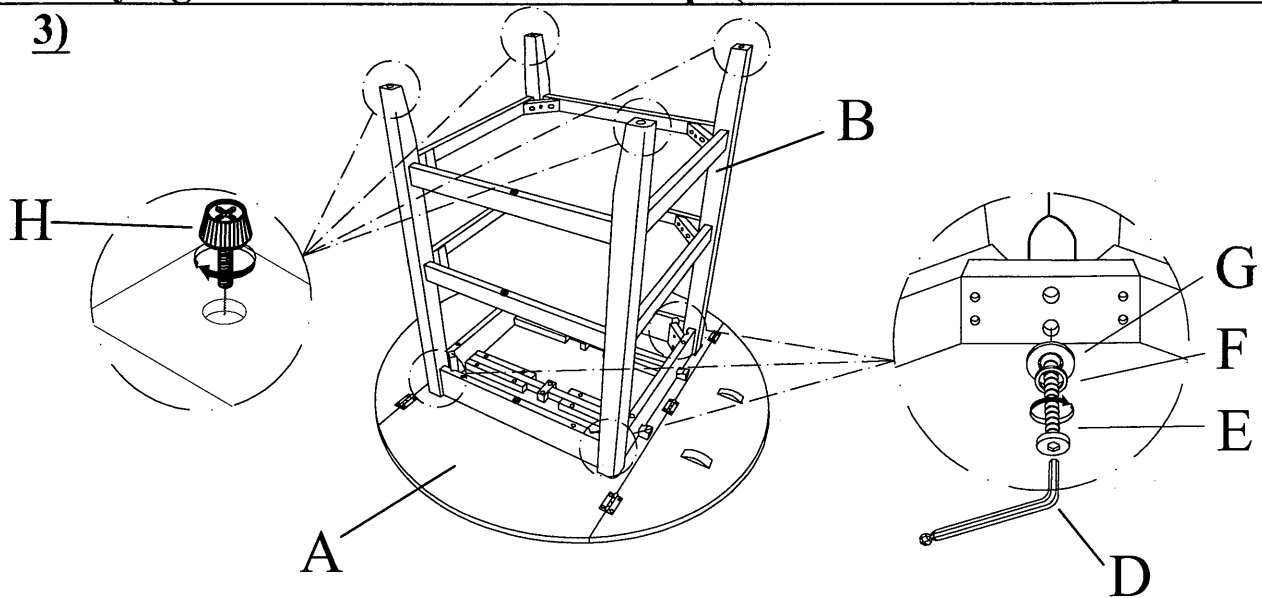

4 Stand table up on the flat surface and check that it is balanced. If there is slight wobble, please adjust the leveler. Lift up the leaf and pull out the wood support which underneath of table top till fixed and tight.

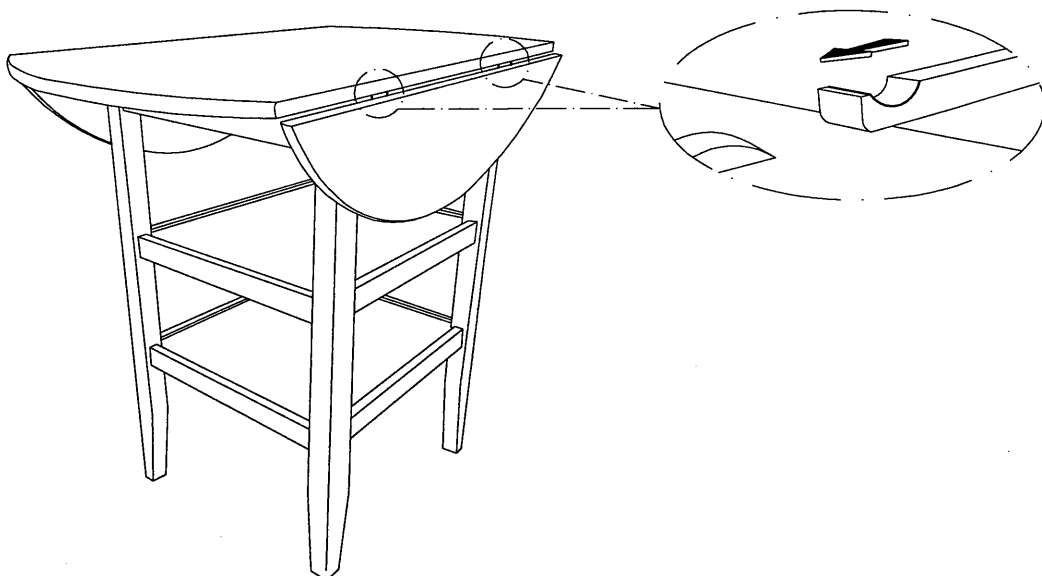









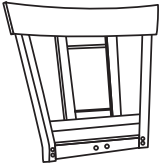

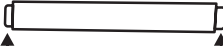
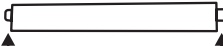
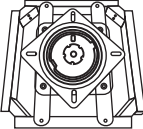
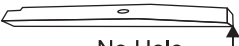
Cleaning & Care

Treat Surface with care. Surface is resistant to scratches but is not scratch resistant. Clean surface with a dry or damp soft cloth. Do not use abrasive cleaners. Hardware may loosen over time. Periodically check that all connections are tight.

ASSEMBLY INSTRUCTION

24" SWIVEL COUNTER HEIGHT CHAIR WITH SQUARE SEAT PANEL BACK 29"H SWIVEL CHAIR

A Backrest  1 PC	B Cushion Seat  1 PC	C Stretcher (Front & Back)  big big 2 PCS	D Stretcher (Left & Right)  small small 2 PCS	E Apron with Swivel Plate  1 PC
F Chair Leg (No Hole)  No Hole 2 PCS	G Chair Leg (Hole)  Hole 2 PCS	H CBS Screw M4 x 38mm  8 PCS	I JCBC Screw M6 x 25mm  4 PCS	J JCBC Screw M6 x 40mm  10 PCS
K JCBC Screw M6 x 70mm  4 PCS	L Flat Washer M6.5 x 16.5mm  18 PCS	M Spring Washer M6 x 13mm  14 PCS	N Allen Key M4  1 PC	



This page lists all the contents included in the box. Please take the time to identify the hardware as well as the individual components to this product. As you unpack and prepare for assembly, place the contents on a carpeted or padded area to protect them from damage.

1

Attach the 2 Pcs Chair Leg (Hole) (G) oppositely to the Apron with Swivel Plate (E), using JCBC Screw (J), Spring Washer (M), Flat Washer (L) with Allen Key (N).

Do not fully tighten the screws at this step. Fully tighten the screws after step 3 and 4. While assemble, must facing toward arrow.

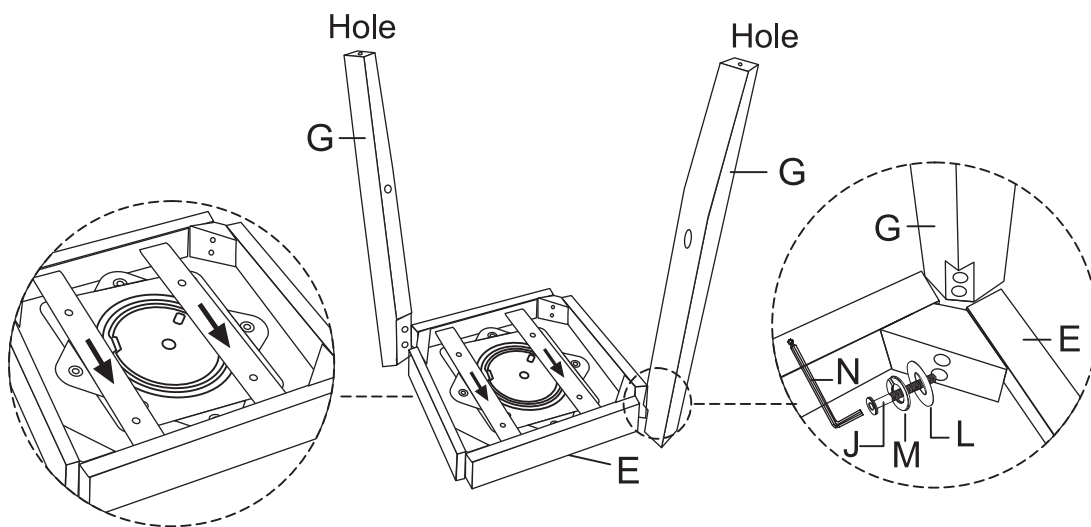

FACING FRONT TOWARD ARROW

Take the Allen Key, and turn the screw until the legs are secured.

DO NOT TIGHTEN COMPLETELY.

Stop when you feel you are adding force to tighten the screw.

2

Attach the 2 Pcs Chair Leg (No Hole) (F) to the Apron with Swivel Plate (E), using JCBC Screw (J), Spring Washer (M), Flat Washer (L) with Allen Key (N).

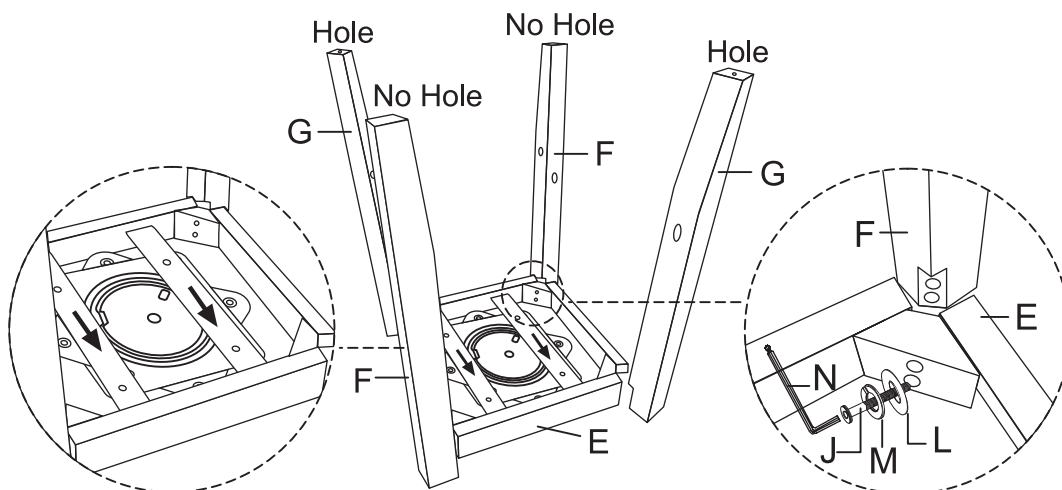

FACING FRONT TOWARD ARROW

3

Then attach the Stretcher (Front & Back) (C) to the big hole on the Chair Leg (F) & (G) with CBS Screw (H).

At Step 3 and 4, align mounting position of the stretcher (C) & (D) to the Chair Leg (F) & (G). At this moment, **DO NOT** use the CBS Screw (H) to tighten first. You only can **FULLY TIGHTEN AFTER YOU HAVE FULLY TIGHTEN THE SCREWS AT STEP 1 AND 2.**

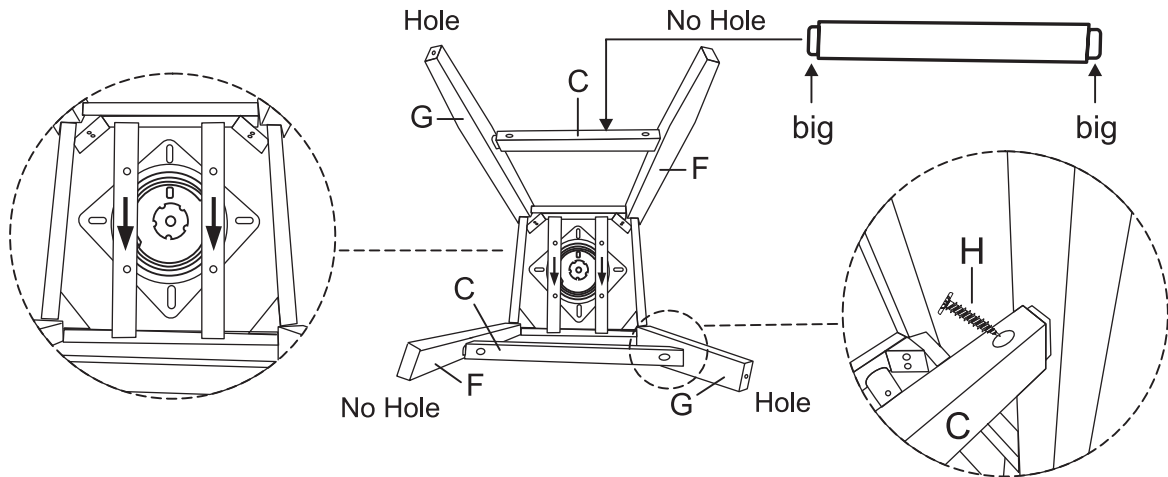

FACING FRONT TOWARD ARROW

4

Then attach the Stretcher (Left & Right) (D) to the small hole on the Chair Leg (F) & (G) with CBS Screw (H).

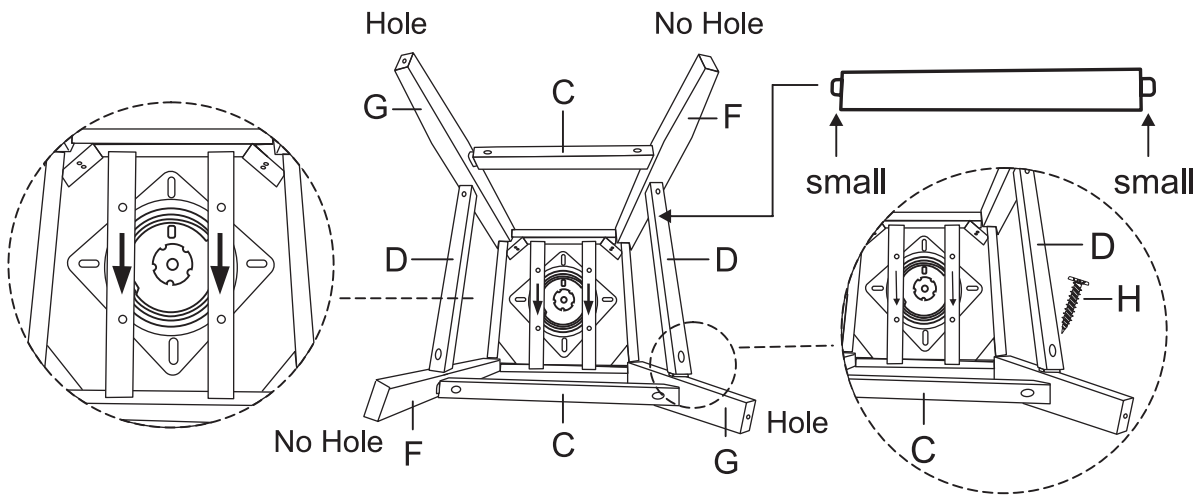

FACING FRONT TOWARD ARROW

- 5** Invert Cushion Seat (B) and place on a stable raised surface (i.e. Table). Attach the Backrest (A) to the Cushion Seat (B), using JCBC Screw (K), Spring Washer (M), Flat Washer (L) with Allen Key (N).

Then, affix the center JCBC Screw (J), Spring Washer (M), Flat Washer (L) with Allen Key (N).

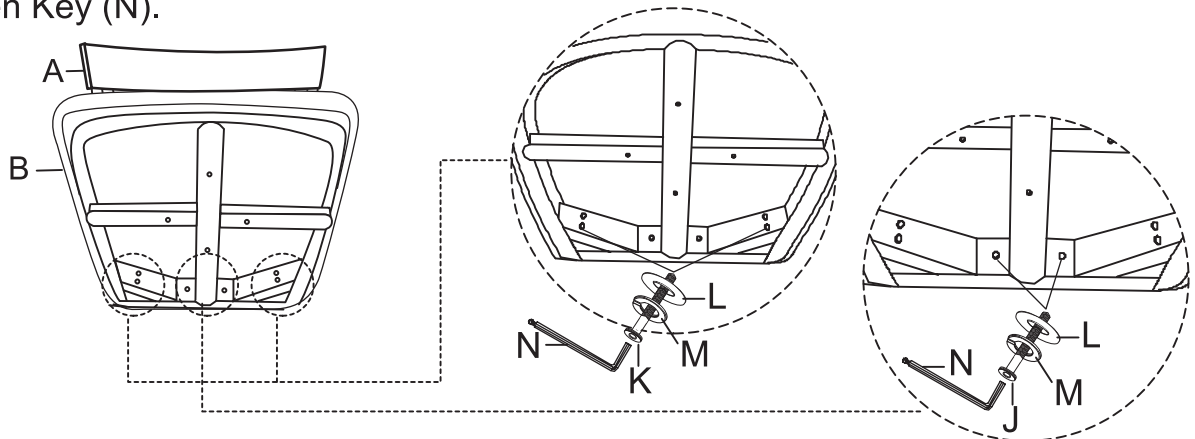

- 6** Keep the Backrest (A) and Cushion Seat (B) inverting on a stable raised surface. Attach the Swivel Plate located on the Apron with Swivel Plate (E) to the Cushion Seat (B) using JCBC Screw (I), Flat Washer (L) with Allen Key (N). Turn the Chair right side up.

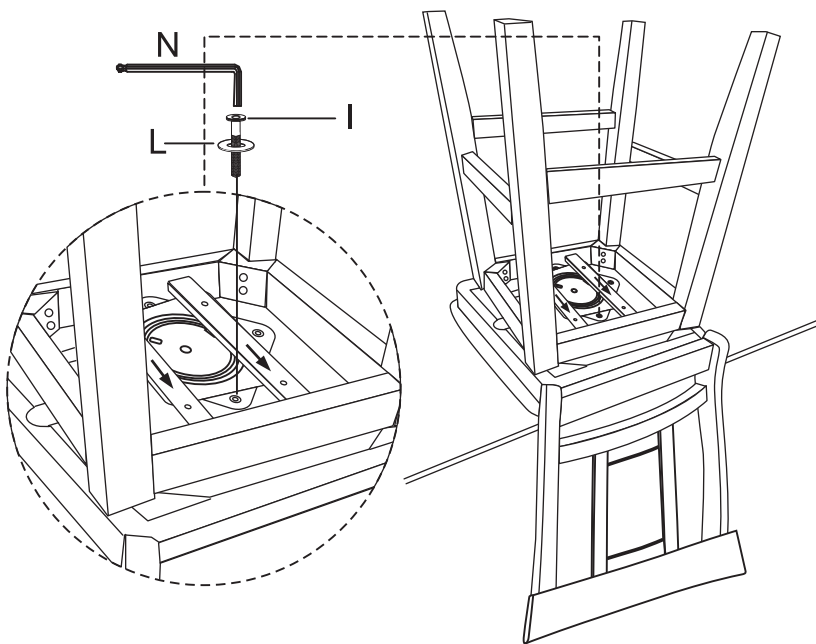

FACING FRONT TOWARD ARROW

Stand chair up on an even surface and check that it is balanced. If there is a slight wobble, apply downward pressure in the corner where a leg is uneven. Keeping pressure in that corner, tighten all bolts. If balanced, apply downward pressure evenly in the center and tighten all bolts. Do not over-tighten beyond hole depth.

Helpful Tip:

Instead of applying downward pressure while reaching under to tighten bolts, have someone sit on the chair while you tighten the bolts.

ENSURE THAT ALL SCREWS ARE FULLY DRIVE IN AND TIGHTEN BEFORE READY TO USE.

CLEANING & CARE

Treat surface with care. Surface is resistant to scratches but is not scratch resistant. Clean surfaces with a dry or damp soft cloth. Do not use abrasive cleaners. Hardware may loosen over time. Periodically check that all connections are tight.