

Product Specifications

3.3-Gallon Square Container with EZ Cover®

Multiple Uses

Dry Products

Product Codes

Container: **S337**

Description: 3.3-gallon square can

Cover: **STDR**

Description: Tamper-evident, square EZ Cover® with Ring Pull™

Features

Built in hand grips
 Gauge: 65 mil.
 Nominal capacity: 3.3 USG / 12.5 L
 Stack performance: 175 lbs.*
 Tare weights: Body: 1.10 lbs. / .50 kgs.
 Cover: .37 lbs. / .17 kgs.

Note: *Ratings will be reduced with uneven load distribution.

Specifications with Cover

Dimensions: 9-15/16" X 9-15/16" X 11-3/16"H
 Maximum capacity: 3.35 USG / 12.7 L
 Tare weight: 1.47 lbs. / .67 kgs.

Colors

Standard: White, Black, Natural and Clear
 Custom: Available at manufacturer's discretion

Decorating Options

Silk - Screening: 5"W X 6-1/4"H
 Four or six* color offset printing
 Print area: 5"W X 6-3/4"H on each panel
 Sleeve or pressure sensitive labeling

Note: *Where available

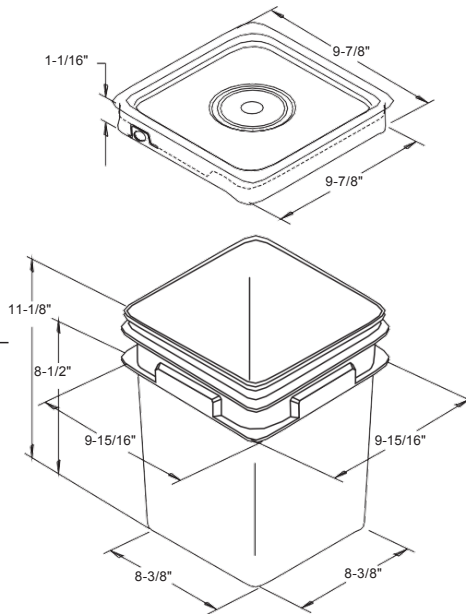

Shipping Data

	Bodies	Covers
Qty. per pallet:	240	2,304 (24 boxes of 96)*
Gross Weight (lbs./kgs.)**:	264/120	852.5/391.7
Den. (lbs./C.F./kgs./m3):	4.9/79	8.0/129.9
Length (in./cm.):	50.5/128.3	51/129.5
Width (in./cm.):	41.5/105.4	41/104.1
Height (in./cm.):	44.2/112.3	89/223.6

Filled Containers

60 (20 per layer / 3 layers high)
 Pallet height: 38.06"

Estimated truckload quantity of 11,040 bodies and covers***

Notes: *Bulk pack also available
 **Weight does not include pallet/packaging
 ***Truckload quantity based on 53' trailer

Materials

FDA approved materials
 Resin: Body: High-Density Polyethylene (HDPE)
 or Clear Polypropylene (PP)
 Cover: High-Density Polyethylene (HDPE)
 MSDS Sheets available upon request

Optional Carrying Handle

DISCLAIMER

THIS INFORMATION IS PROVIDED AS A GENERAL GUIDE, INCLUDING DIMENSIONS. IT IS THE CUSTOMER'S RESPONSIBILITIES TO SELECT THE PROPER CONTAINER FOR PRODUCT AND APPLICATION COMPATIBILITY.

DISTRIBUTED BY:



REF NO.:

DWG30571

DESCRIPTION:

3.3 Gallon Square HDPE Open Head Pail