

CAUTION: Carefully read instructions and procedures for safe operation. **DO NOT USE** if this product should become damaged and/or components are broken. Check this product for damaged hardware, loose joints, loose bolts or other fasteners, missing parts or sharp edges before and after assembly. Assembly of this product will require two people.

AVERTISSEMENT: Lisez toutes les intructions avant de monter le lit de bébé. Avant d'utiliser ou de monter le lit de bébé, inspectez-le pour vous assurer qu'il n'y a pas de pièces endommagées, d'articulations deserrées, de pieces manquantes ou de bords tranchants. N'utilisez pas le lit de bébé si certaines pièces sont manquantes ou brisées. L'assemblage de ce produit nécessite deux personnes.

ADVERTENCIA – Por seguridad, Lea completamente las instrucciones antes del ensamblaje y uso. Inspeccioné su producto por piezas dañadas, faltantes o sueltas, bordes filosos o astillas antes, durante y después del uso. El ensamblaje requiere dos personas.

Please store this manual in the plastic pouch for future reference.
 Veuillez gardez ces instruction dans la pochette plastique pour future références.
 Guardar estas instrucciones en su sobre plástico para referencias.

NEED PRODUCT SUPPORT?

Our Customer Care team is here for you.

If you have any questions about assembling your product, or have any concerns relating to parts, shipping, or your new product, get in touch with our Customer Care team first and they will be happy to let you know what to do next. We're available Monday to Friday, from 6:30 am – 4:00pm PST / 9:30 am – 7:00 pm EST.

Please have the following product information ready, located on the white sticker label on your product:

Model number | PO number | Date of manufacture

Here are a few easy ways to contact us:

- Online at www.storkcraftdirect.com via our live chat
- Email us at customercare@storkcraft.com
- Call us toll-free in North America at 1.877.274.0277

We look forward to hearing from you.

NECESITA AYUDA CON SU PRODUCTO?

Nuestro equipo de atención al cliente está aquí para ayudarle.

Si tiene alguna duda con el ensamblaje de su producto o si tiene alguna pregunta acerca del envío, partes; y/o si desea información de su nuevo producto, por favor, póngase en contacto primero con nuestro equipo de atención al cliente.

Nuestro equipo estará feliz de ayudarle. Estamos disponibles de Lunes a Viernes de 6:30am a 4pm PST / 9:30am a 7pm EST.

Por favor tenga la información completa del producto a la mano. Esta se encuentra ubicada en la etiqueta blanca pegada al producto: **Número de modelo | Numero postal | Fecha de manufactura**

La manera más fácil de contactarnos es:

- Por nuestro chat en línea a través de nuestra página web www.storkcraftdirect.com
- Por correo electrónico a customercare@storkcraft.com
- Por teléfono sin costo al 1-877-274-0277 en Norte América.

Será un placer asistirle.

BESOIN D'AIDE AVEC VOTRE PRODUIT ?

Notre service à la clientèle est ici pour vous aider.

Si vous avez des questions au sujet de l'assemblage de votre produit ou si vous avez des préoccupations au sujet du produit lui-même, des pièces ou de la livraison, veuillez contacter notre service à la clientèle et nous serons heureux de vous aider.

Nous sommes disponible du Lundi au Vendredi de 6:30am - 4:00pm (HNP) / 9:30am - 7:00pm (HNE).

Veuillez s'il vous plaît vous assurer d'avoir les informations suivantes en main. Celles-ci se trouvent sur l'étiquette blanche située sur votre produit: **Numéro de Modèle | Numéro de PO | Date de fabrication**

Voici deux manières faciles de nous contacter :

- Par courrier électronique : customercare@storkcraft.com
- Par téléphone : En Amérique du Nord composez sans frais 1-877-274-0277

N'hésitez pas à nous contacter.

SAFETY WARNING

1. Follow the information on the warnings appearing on the upper bunk end structure and on the carton. Do not remove warning label from bed.
2. Always use the recommended size mattress or mattress support, or both, to help prevent the likelihood of entrapment or falls.
3. Surface of mattress must be at least 5 in. (127 mm) below the upper edge of guardrails.
4. Do not allow children under 6 years of age to use the upper bunk.
5. Periodically check and ensure that the guardrail, ladder, and other components are in their proper position, free from damage, and that all connectors are tight.
6. Do not allow horseplay on or under the bed and prohibit jumping on the bed.
7. Prohibit more than one person on upper bunk.
8. Always use the ladder for entering and leaving the upper bunk.
9. Do not use substitute parts. Contact the manufacturer or dealer for replacement parts.
10. Use of a night light may provide added safety precaution for a child using the upper bunk.
11. Always use guardrails on both long sides of the upper bunk. If the bunk bed will be placed next to the wall, the guardrail that runs the full length of the bed should be placed against the wall to prevent entrapment between the bed and wall.
12. The use of water or sleep flotation mattresses is prohibited.
13. STRANGULATION HAZARD—Never attach or hang items to any part of the bunk bed that are not designed for use with the bed; for example, but not limited to hooks, belts and jump ropes.
14. Keep these instructions for future reference.

SIZE OF MATTRESS AND FOUNDATION:

Use only mattress, which is 37 1/2" - 38 1/2" width and 74"-75" long on upper bunk and lower bunk (twin size.)

Ensure that the thickness of the mattress does not exceed 7" and that the mattress surface is at least 5" (127mm) below upper edge of guardrails.

WARNING:

Adult Assembly Required. This package contains small parts. Keep away from children.

Replacement Parts:

Replacement parts, including additional guardrails may be obtained from any Stork Craft Mfg. Inc.'s dealer.

Distributed by:
Stork Craft Mfg. (USA), Inc.,
3993 Howard Hughes Parkway, Unit#250
Las Vegas, NV, USA.89169
Tel: 1 877 274 0277

MISE EN GARDE

1. Suivre la mise en garde apparaissant sur la structure du lit du haut et sur le carton. Ne pas enlever l'avertissement apparaissant sur le lit.
2. Toujours utiliser la grandeur de matelas et de support recommandée pour prévenir les possibilités d'emprisonnement ou de chutes.
3. La surface du matelas doit être au moins à 127 mm (5") du bord du rail de protection.
4. Ne pas permettre à un enfant de moins de 6 ans d'utiliser le lit supérieur.
5. Périodiquement vérifier et s'assurer que le rail de protection, l'échelle et les autres pièces sont à leur place respective et en bonne position; quelles ne sont pas endommagées et que toutes les connections sont bien serrées.
6. Ne pas jouer ni sauter sur ou sous le lit.
7. Interdire la présence de plus d'une personne sur le lit supérieur.
8. Toujours utiliser l'échelle pour monter et descendre du lit supérieur.
9. Ne pas utiliser de pièces de substitution. Contacter le manufacturier ou le détaillant pour obtenir des pièces de remplacement.
10. Utilisation d'une veilleuse ajouterait une précaution de sécurité pour les enfants utilisant le lit supérieur.
11. Toujours utiliser les rails de protection sur les deux côtés longs du lit supérieur. Si le lit superposé a été placé le long d'un mur, le rail de protection qui est de pleine longueur du lit doit être placé le long du mur pour éviter l'emprisonnement entre le lit et le mur. (Ceci s'applique seulement au lit superposé sans deux rails de protection pleine longueur)
12. L'utilisation de matelas d'eau ou de flotaison est interdite.
13. RISQUE D'ÉTRANGLEMENT-Ne rien attacher ou suspendre au lit superposé tout item qui n'est pas conçu à cet usage, par exemple et sans limite les crochets, ceintures, cordes à danser, etc.
14. Garder ces instructions pour références futures.

FORMAT DES MATELAS ET BASE:

Utiliser seulement un matelas de 37 1/2" - 38 1/2" de largeur et 74"-75" de longueur sur le lit du haut et bas (format jumeaux). S'assurer que l'épaisseur du matelas n'excède pas 7" et que la surface est à moins de 5" (127mm) du bord des rails de protections.

ATTENTION:

Un adulte doit procéder à l'assemblage. Ce paquet contient de petites pièces et doit être tenu loin de la portée des enfants.

Pièces de remplacement:

Les pièces de remplacement, incluant les rails de protection additionnels, peuvent être obtenus chez n'importe quel détaillant de Les Stork Craft Mfg. Inc.

Distributed by:
Stork Craft Mfg. (USA), Inc.,
3993 Howard Hughes Parkway, Unit#250
Las Vegas, NV, USA.89169
Tel: 1 877 274 0277

ADVERTENCIA

1. Siga la información sobre las advertencias que aparecen en la estructura superior de la litera y en la caja de cartón. No retire la etiqueta de advertencia de la litera.
2. Utilice siempre el colchón de tamaño recomendado o soporte del colchón o ambos, para ayudar a prevenir la probabilidad de atrapamiento o caídas.
3. La superficie del colchón debe estar por lo menos 5 pulgadas (12.7 cm) por debajo del borde superior de los barandales.
4. No permita que los niños menores de 6 años de edad utilicen la cama superior.
5. Periódicamente revise y asegúrese de que los barandales, la escalera y las otras partes de la litera estén en su posición correcta, libre de daños, y que los tornillos estén apretados.
6. No permita que los menores jueguen sobre ó debajo de la litera y prohíba que salten en la misma.
7. Prohíba que más de una persona suba a la parte superior de la litera.
8. Siempre utilice la escalera para subir o bajar de la parte superior.
9. No sustituya las piezas. Póngase en contacto con el fabricante o distribuidor para piezas de reemplazo.
10. El uso de la luz de la noche puede proporcionar mayor seguridad para su hijo para tomar las debidas precauciones cuando use la parte superior de la litera.
11. Utilice siempre los barandales de ambos lados de la litera superior. Si la cama se colocará junto a la pared, el barandal que recorre toda la longitud de la cama debe colocarse contra la pared para evitar que queden atrapados entre la cama y la pared.
12. Está prohibido el uso de colchón agua.
13. PELIGRO DE ESTRANGULACION – Nunca fije o cuelgue artículos a cualquier parte de la litera que no están diseñados para su uso con la misma; por ejemplo, los ganchos, correas o cuerdas de saltar.
14. Guarde las instrucciones para futuras referencias.

TAMAÑO DEL COLCHON Y BASE:

Utilice sólo colchón, que es de 37 1/2" - 38 1/2" de ancho y 74" - 75" de largo en la parte superior e inferior literas (dos gemelas.) Asegúrese de que el thicjness del colchón no exceda 7" y que el colchón superficie es por lo menos 5" (127mm) belkow el borde superior de los guardarraíles.

ADVERTENCIA:

Se recomienda ensamblar por un adulto. Este paquete contiene piezas pequeños. Mantener alejado de los niños.

Piezas de Repuesto:

Piezas de repuesto, incluyendo barandales adicionales pueden obtenerse de cualquier distribuidor de Stork Craft Mfg. Inc.

Distributed by:
Stork Craft Mfg. (USA), Inc.,
3993 Howard Hughes Parkway, Unit#250
Las Vegas, NV, USA.89169
Tel: 1 877 274 0277

LIST OF CONFIGURATIONS

TWIN OVER TWIN BUNK BED / TWIN SUR TWIN BUNK BED / LITERA DOBLE SOBRE DOBLE

PAGE 7 / PAGE 7 / PÁGINA 7



KIDS LOFT / PIGEONNIER POUR ENFANTS / LOFT INFANTIL

PAGE 24 / PAGE 24 / PÁGINA 24

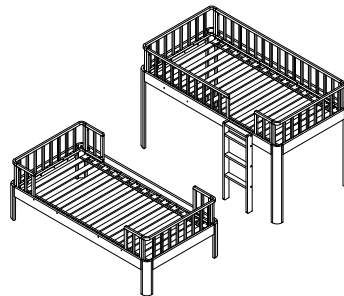

SINGLE BED & DAY BED / LIT SIMPLE ET LIT DE JOUR / CAMA INDIVIDUAL Y CAMA DE DÍA

PAGE 39 / PAGE 39 / PÁGINA 39

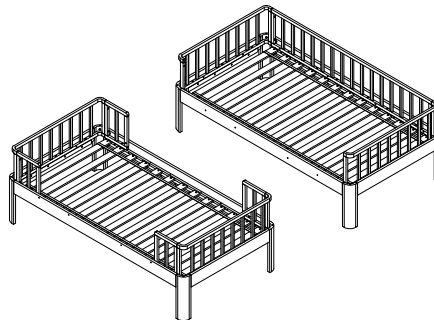

SINGLE BED & TODDLER BED / LIT SIMPLE ET LIT POUR TOUT-PETITS / CAMA INDIVIDUAL Y CAMA PARA NIÑOS PEQUEÑOS

PAGE 50 / PAGE 50 / PÁGINA 50

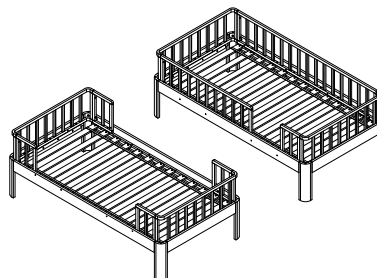

TWO SINGLE BEDS / DEUX LITS SIMPLES / DOS CAMAS INDIVIDUALES

PAGE 62 / PAGE 62 / PÁGINA 62

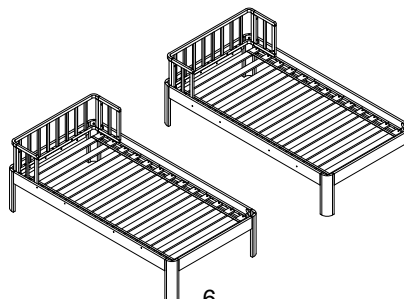

**TWIN-OVER-TWIN BUNK BED / TWIN SUR TWIN
BUNK BED / LITERA DOBLE SOBRE DOBLE**

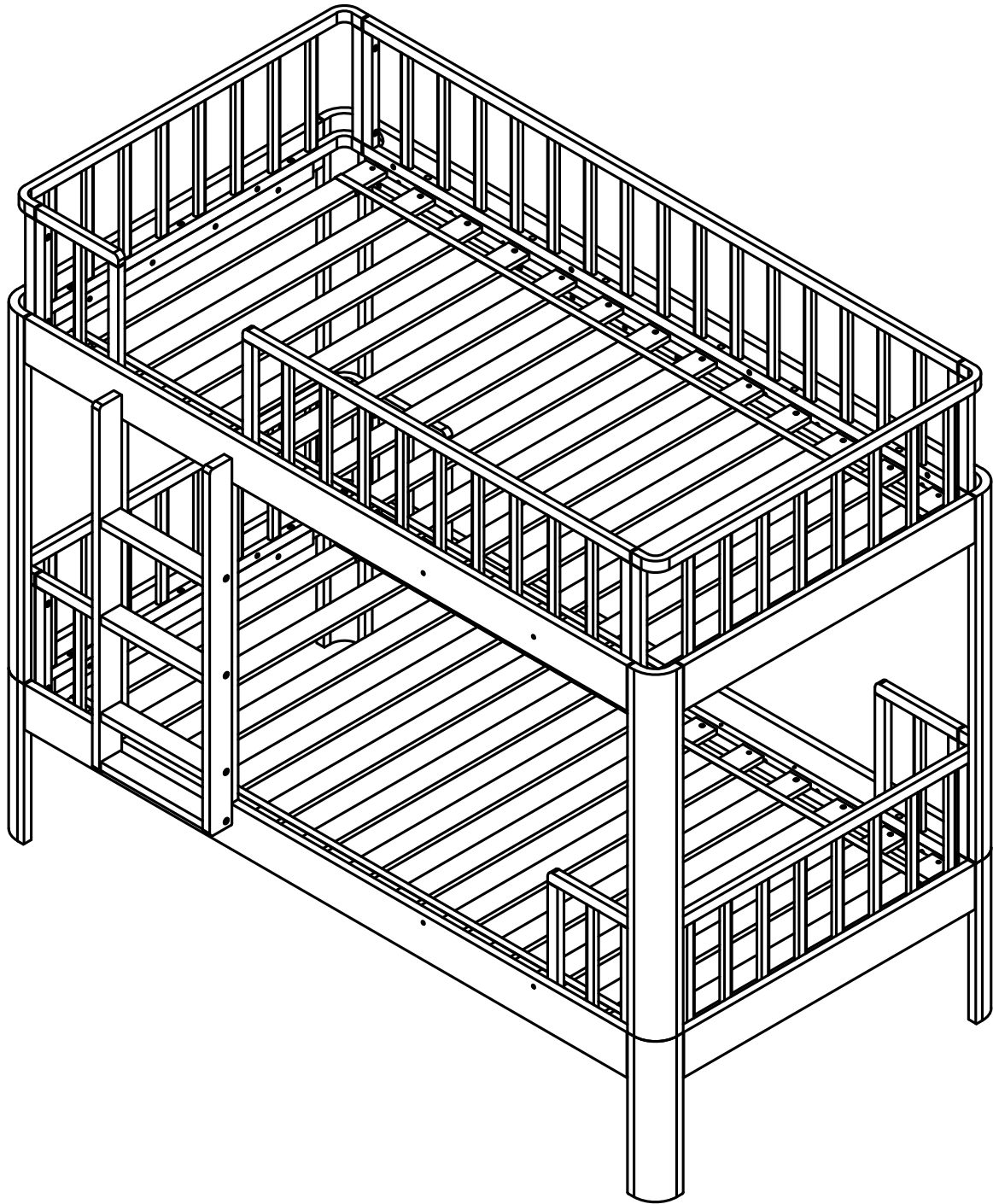

Identifying The Parts/Identification des pièces/ Identificación de piezas

ASSEMBLY TIPS

1. Remove hardware from box and sort by size.
2. Please check to see that all hardware and parts are present prior start of assembly.
3. Please follow attached instructions in the same sequence as numbered to assure fast and easy assembly.

WARNING!

1. Don't attempt to repair or modify part that are broken or defective. Please contact the store immediately.
2. This product is for home use only and not intended for commercial establishments.

RECOMENDACIONES DE ENSAMBLAJE

1. Retire el herraje de la caja y ordene por tamaño.
2. Por favor compruebe que todo el herraje y piezas estén listas antes del inicio del ensamble.
3. Por favor siga las instrucciones adjuntas en la misma secuencia numerada para asegurar un ensamblado rápido y fácil.

ADVERTENCIA!

1. No intente reparar o modificar si alguna pieza está rota o defectuosa. Por favor, póngase en contacto con la tienda de inmediato.
2. Este producto es para uso doméstico solamente y no destinado a establecimientos comerciales.

CONSEILS DE MONTAGE

1. Retirez le matériel de la boîte et de tri par taille.
2. Se il vous plaît vérifier que tout le matériel et les pièces sont présentes avant début de réunion .
3. Se il vous plaît suivre les instructions jointes dans la même séquence que numéroté pour assurer un montage rapide et facile .

ATTENTION!

1. À ne pas tenter de réparer ou de modifier une partie qui sont cassé ou défectueux. Se il vous plaît contactez immédiatement le magasin.
2. Ce produit est pour un usage domestique seulement et non destinés à des établissements commerciaux.



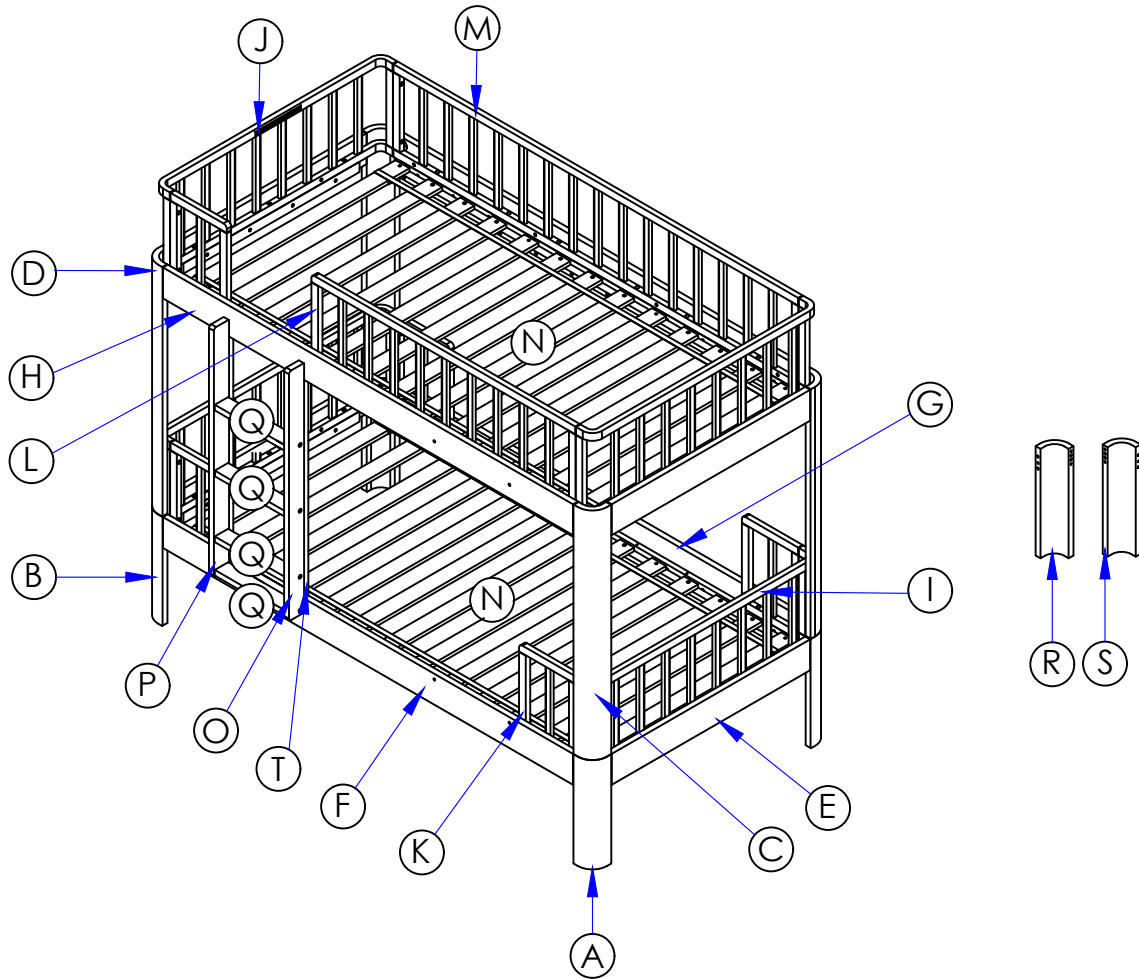











Identifying The Parts/Identification des pièces/ Identificación de piezas



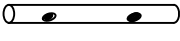

Part	Name Of Part List	Qty
A	Lower leg (Left rear & right front)	2pcs
B	Lower leg (Left front & right rear)	2pcs
C	Upper leg (Left rear & right front)	2pcs
D	Upper leg (Left front & right rear)	2pcs
E	Headboard/Footboard rail	4pcs
F	Lower front side rail	1pc
G	Upper & lower rear side rail	2pcs
H	Upper front side rail	1pc
I	Headboard/Footboard frame	2pcs
J	Headboard/Footboard frame with sticker	2pcs

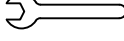
Part	Name Of Part List	Qty
K	Short guard frame	5pcs
L	Upper Front Guard Frame	1pc
M	Upper Rear Guard Frame	1pc
N	Slat	2sets
O	Right ladder rail	1pc
P	Left ladder rail	1pc
Q	Ladder stretcher	4pcs
R	Extra Lower Leg (Left Rear & Right Front)	2pcs
S	Extra Lower Leg (Right Rear & Left Front)	2pcs
T	Support rail	2pcs

HARDWARE PACK



NO.	DESCRIPTION		DIMENSION	QTY
1	Bolts		M6 x 60mm	8 pcs
2	Bolts		M6 x 40mm	24 pcs
3	Bolts		M6 x 16mm	16 pcs
4	Bolts		M6 x 40mm	27 pcs
5	Bolts		M6 x 28mm	16 pcs
6	Wood Screw		M4.0 x 28mm	56 pcs
7	JCN Nut		M6	8 pcs
8	Wood Dowel		Ø10 x 30mm	40 pcs
9	Barrel Nut		M6 x 13mm	8 pcs
10	Metal Pin With Hole		Ø10 x 100mm	4 pcs
11	Hanger Bolts		M8 x 60mm	24 pcs
12	H/M Washer		M8	24 pcs
13	H/M Nut		M8	24 pcs
14	Wrench		M8	1 pc
15	Allen Key		M4	1 pc

Step 1/ Étape 1/ Paso 1

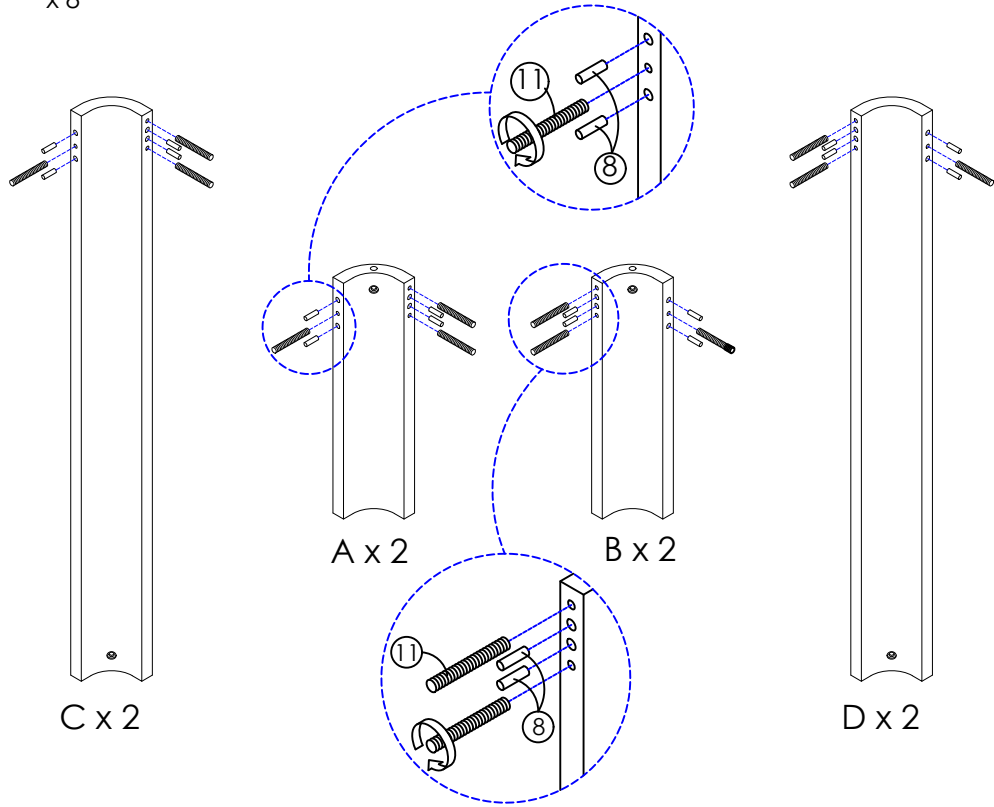
- ①  x 8
- ⑨  x 8



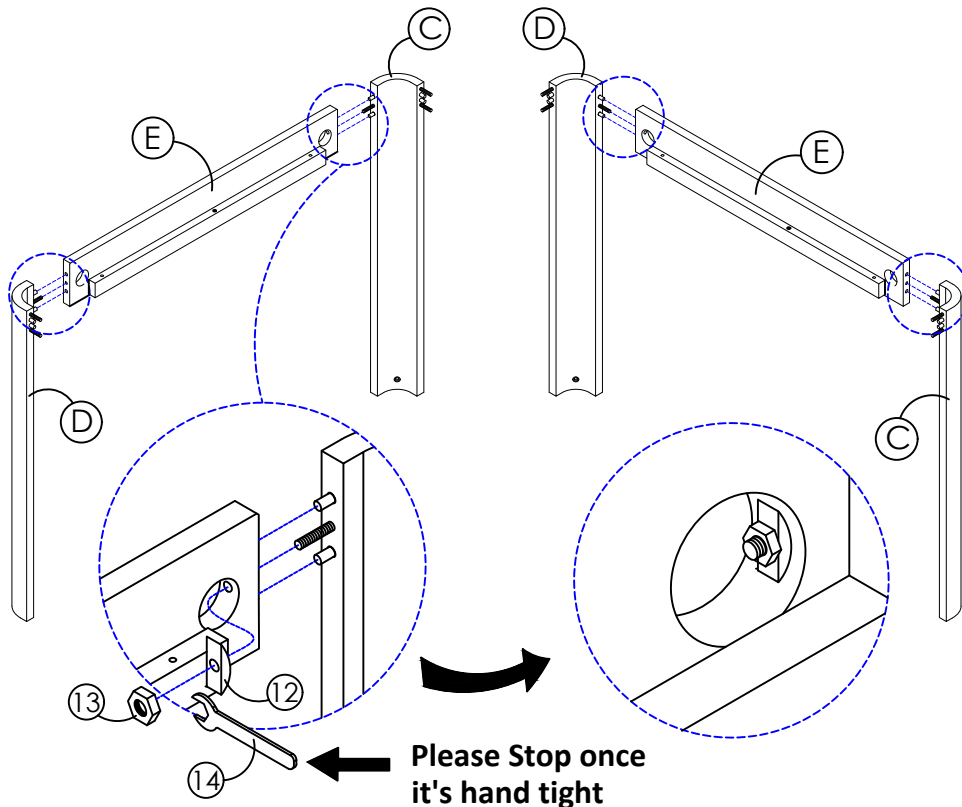

Step 2/ Étape 2/ Paso 2

- ⑫  x 4
- ⑬  x 4
- ⑭  x 1



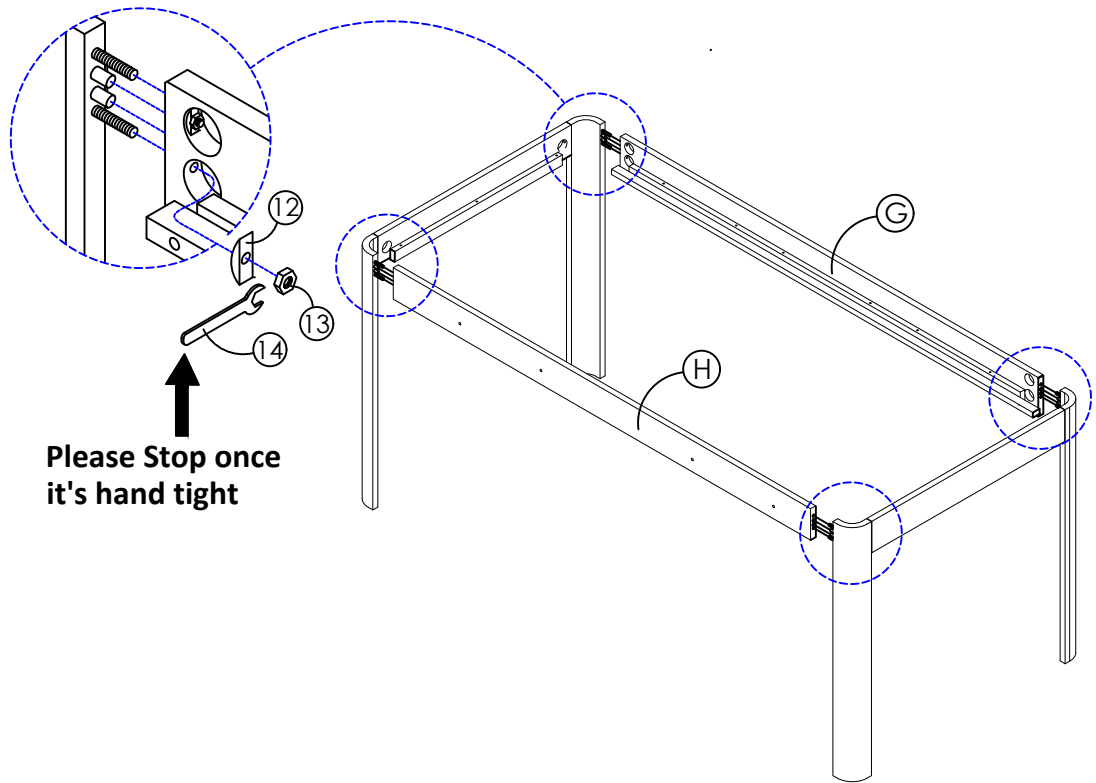

Step 3/ Étape 3/ Paso 3

- ⑫  x 8
- ⑬  x 8
- ⑭  x 1





Please Stop once
it's hand tight

Step 4/ Étape 4/ Paso 4

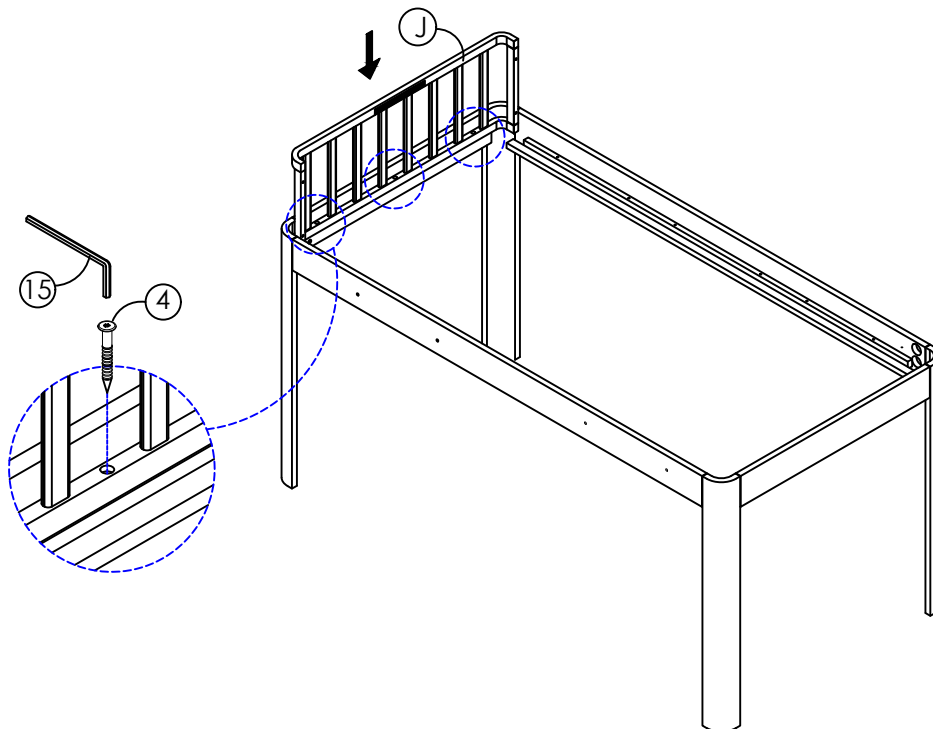
- ④  x 3
- ⑮  x 1



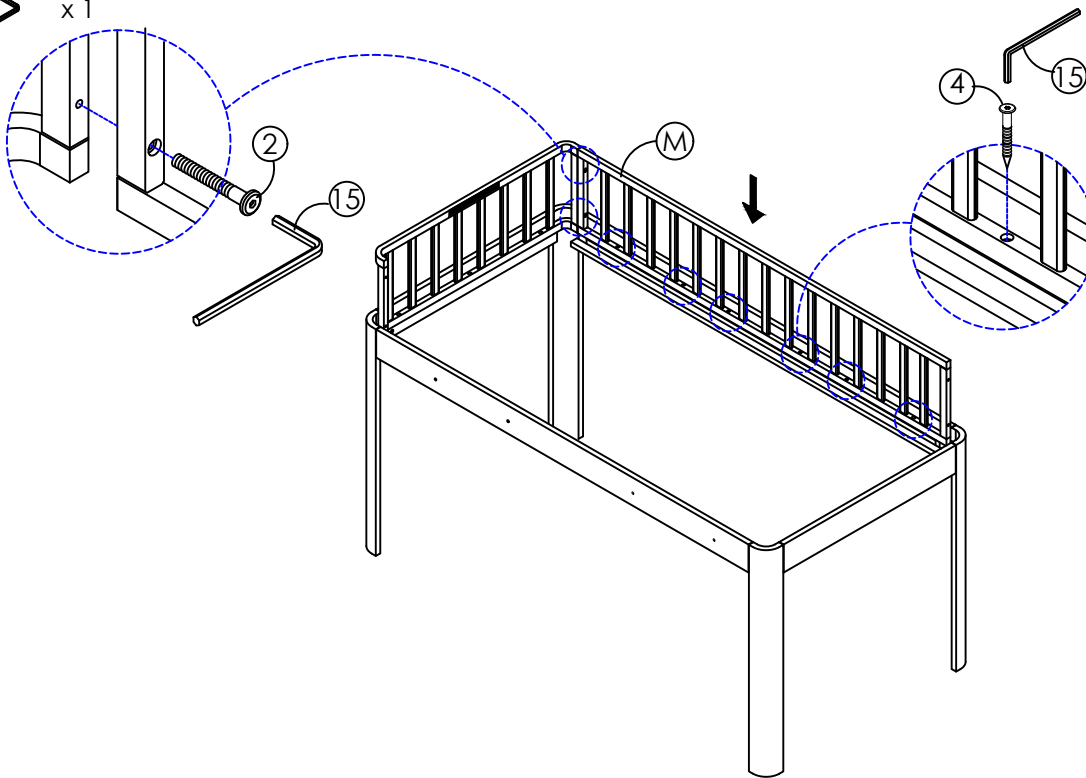

Step 5/ Étape 5/ Paso 5

- ②  x 2
- ④  x 6
- ⑮  x 1



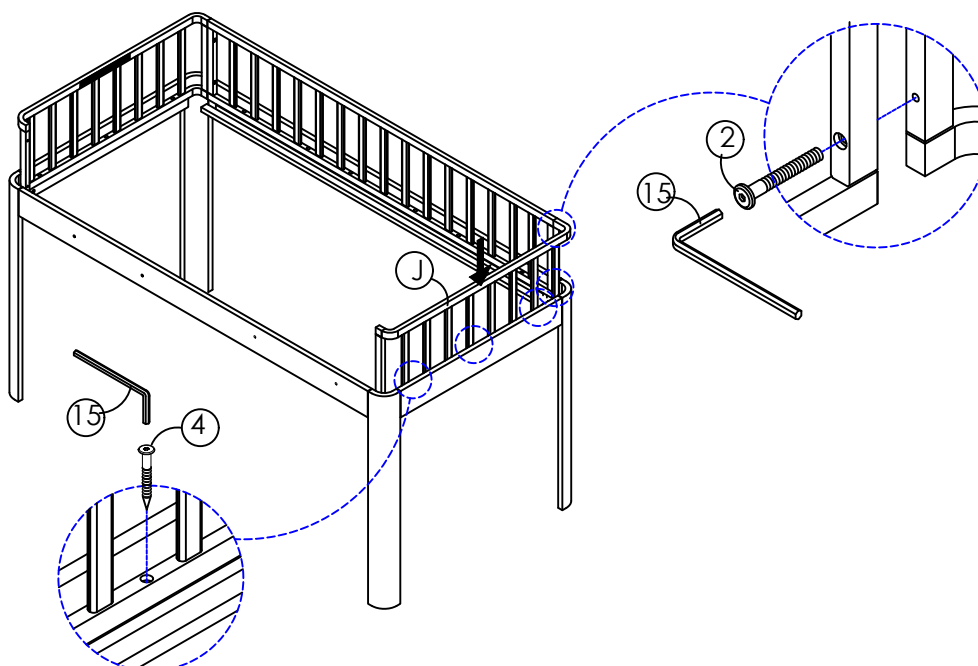

Step 6/ Étape 6/ Paso 6

- ②  x 2
- ④  x 3
- ⑮  x 1



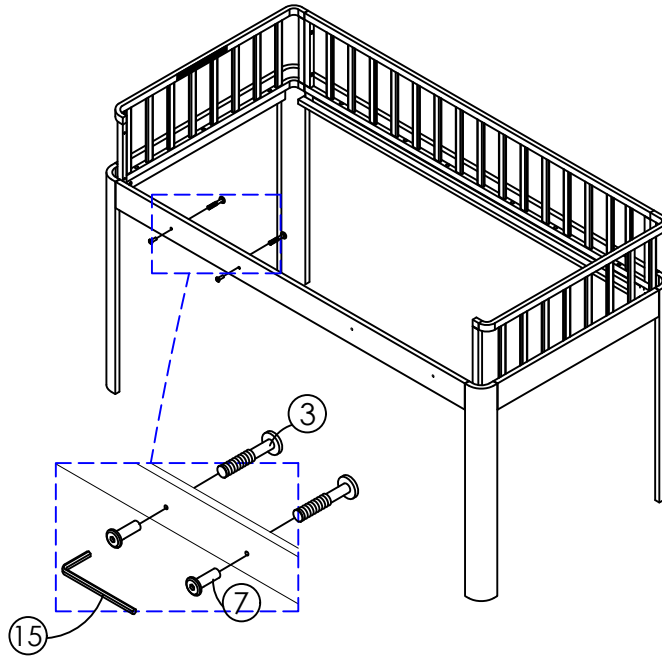
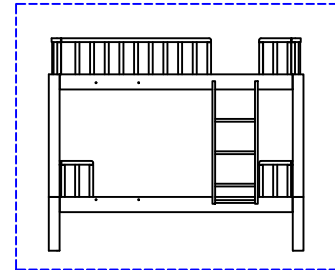

Step 7/ Étape 7/ Paso 7

- ③  x 2
- ⑦  x 2
- ⑮  x 1



Step 8/ Étape 8/ Paso 8

- ②  x 4
- ④  x 6
- ⑮  x 1

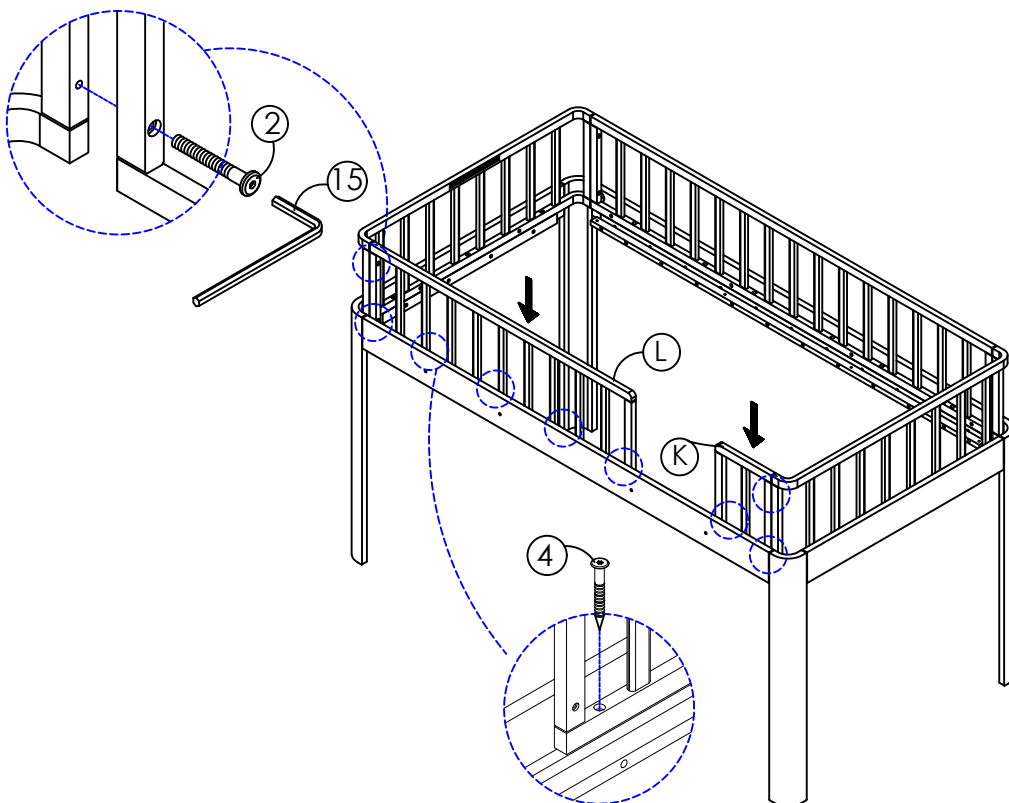
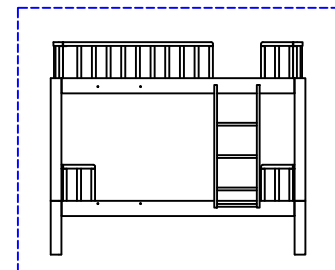

Step 9/ Étape 9/ Paso 9

⑥  x 12

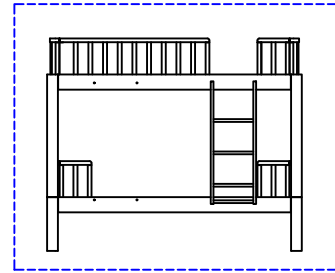
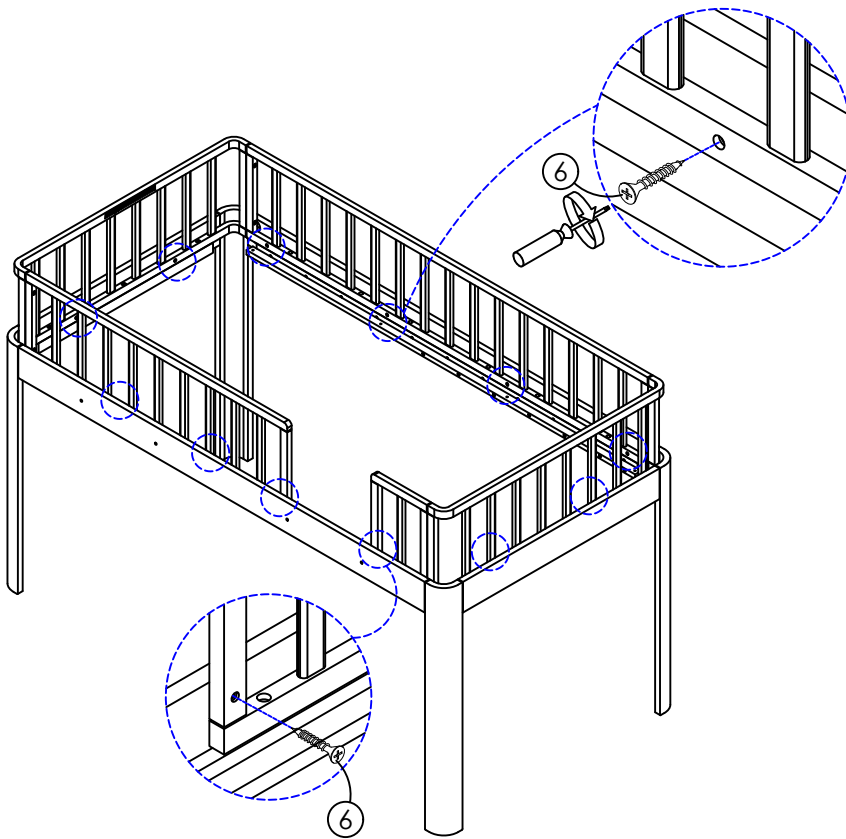

Step 10/ Étape 10/ Paso 10



③  x 2

⑦  x 2

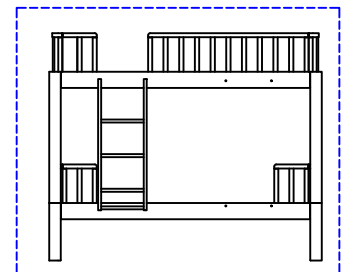
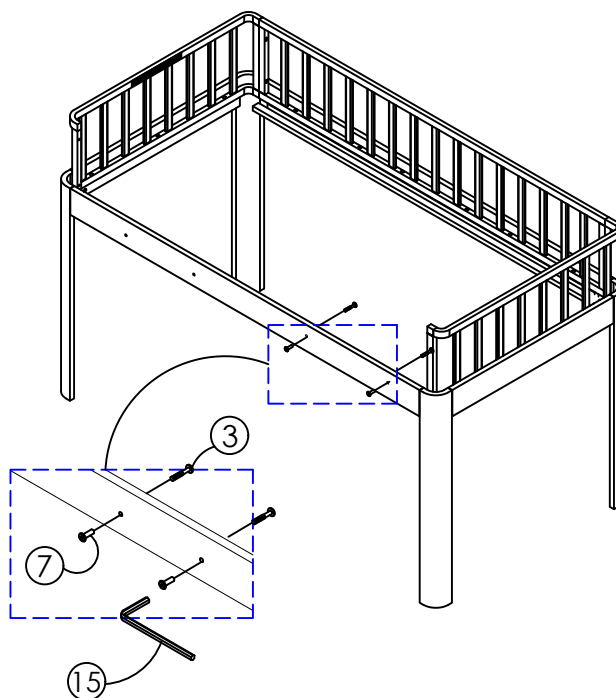
⑮  x 1



Step 11/ Étape 11/ Paso 11

- ②  x 4
- ④  x 6
- ⑮  x 1

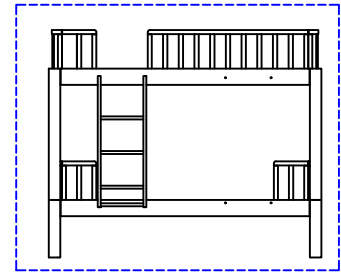
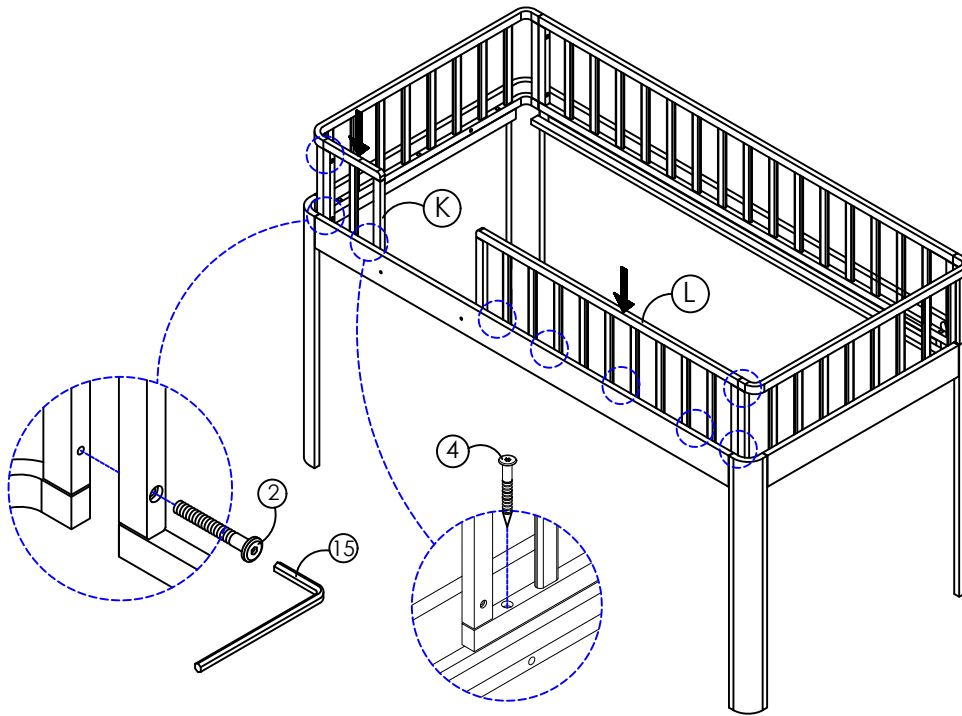

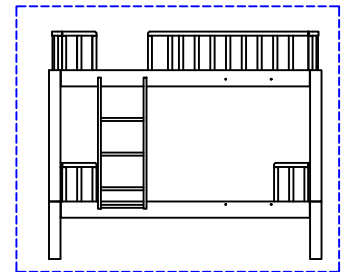
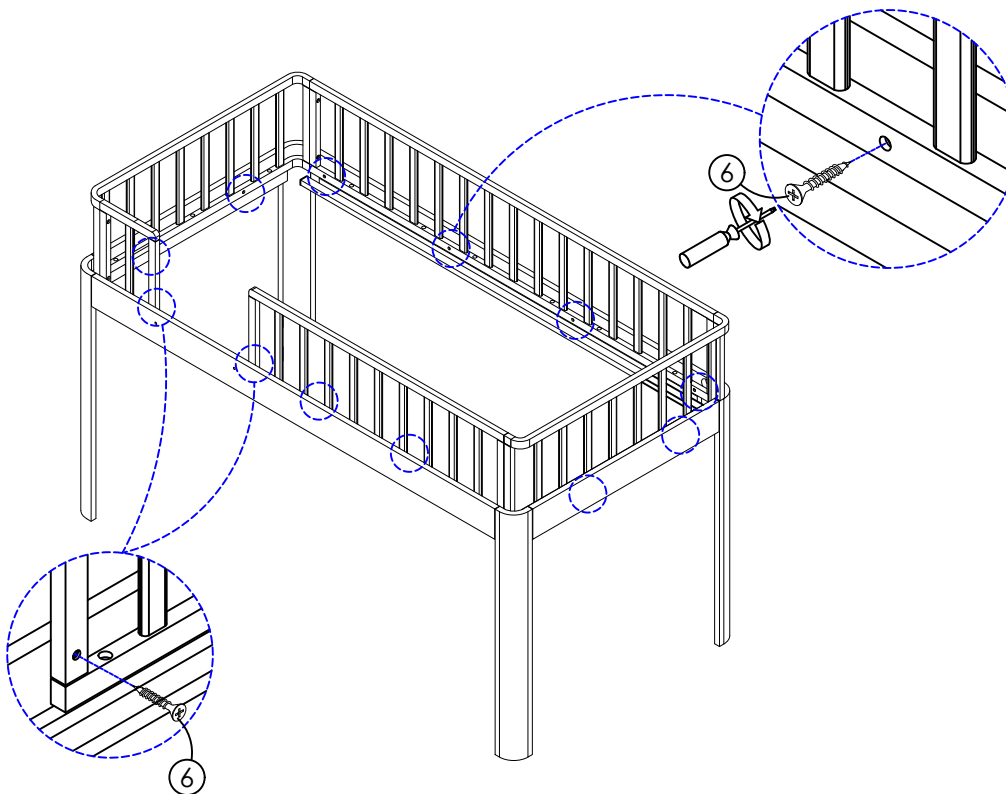

Step 12/ Étape 12/ Paso 12

- ⑥  x 12



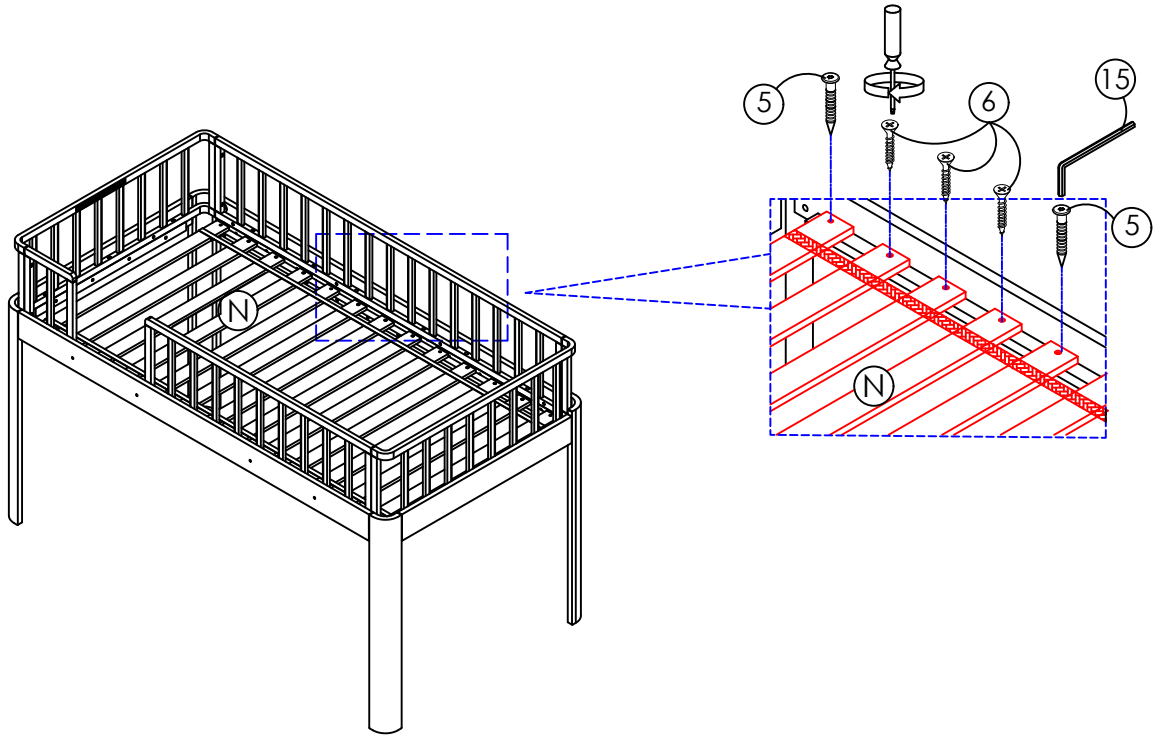

Step 13/ Étape 13/ Paso 13

- ⑥  x 18
- ⑤  x 8
- ⑮  x 1



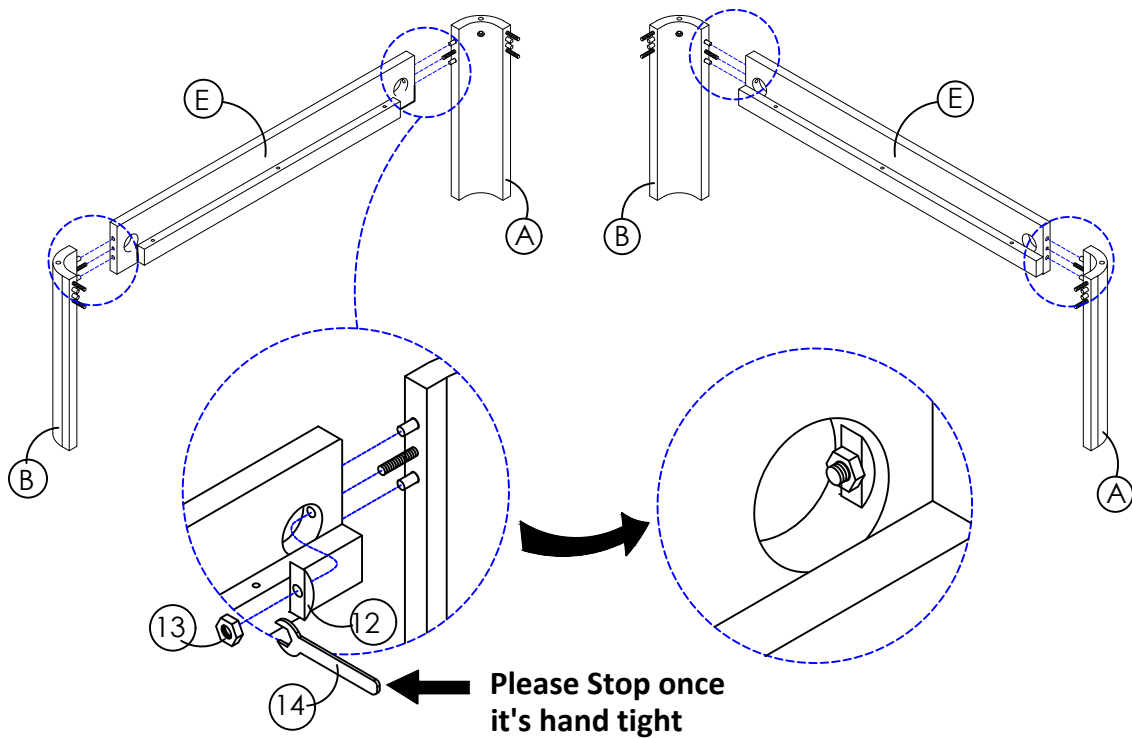

Step 14/ Étape 14/ Paso 14

- ⑫  x 4
- ⑬  x 4
- ⑭  x 1



Step 15/ Étape 15/ Paso 15

- ⑫  x 8
- ⑬  x 8
- ⑭  x 1

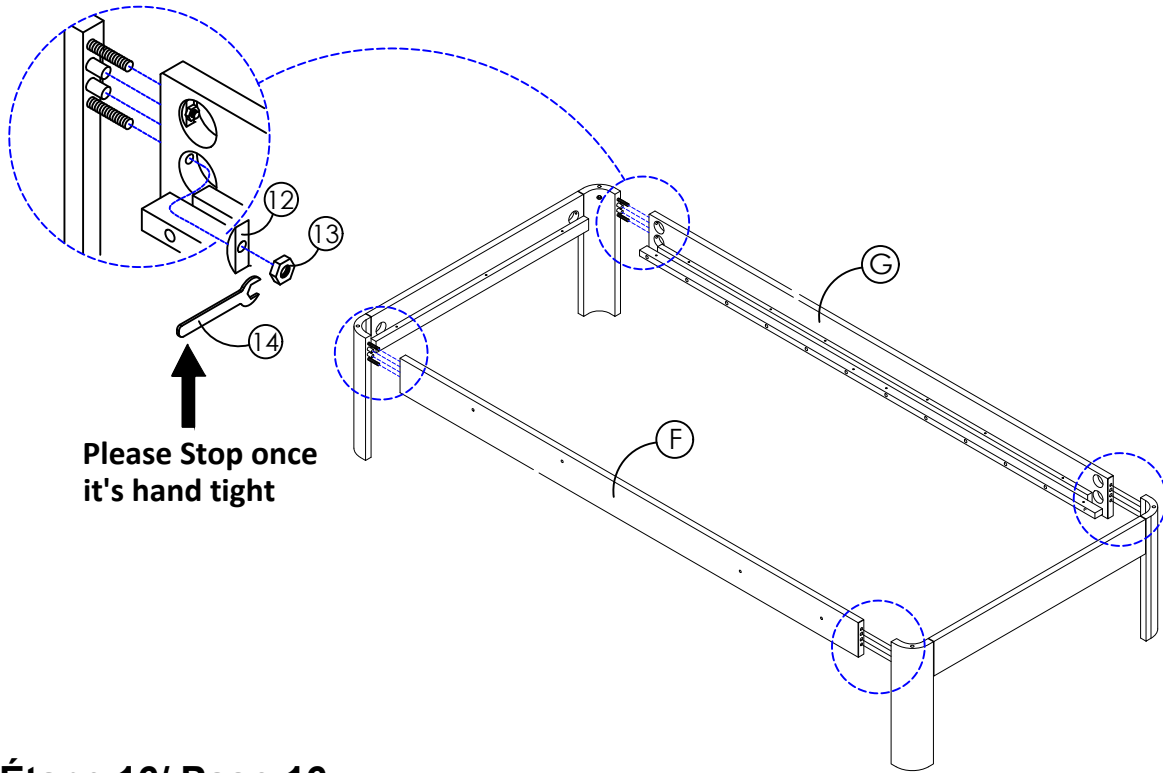

Please Stop once it's hand tight

Step 16/ Étape 16/ Paso 16

- ②  x 8
- ⑮  x 1

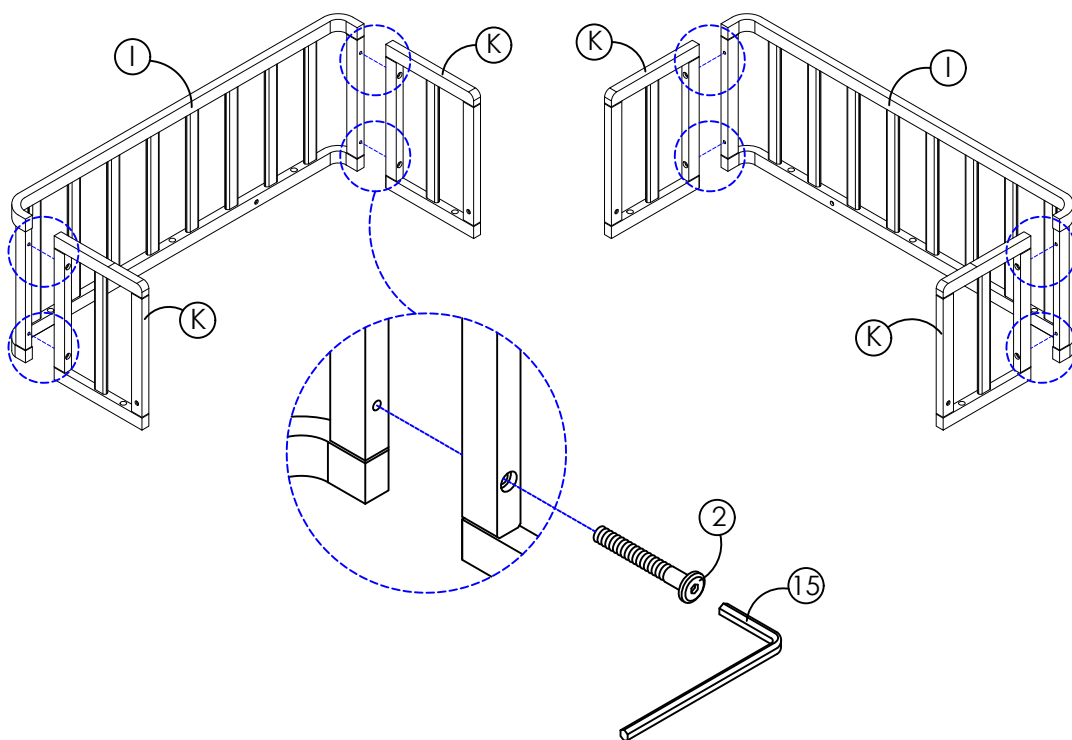

Step 17/ Étape 17/ Paso 17

④  x 10

⑮  x 1

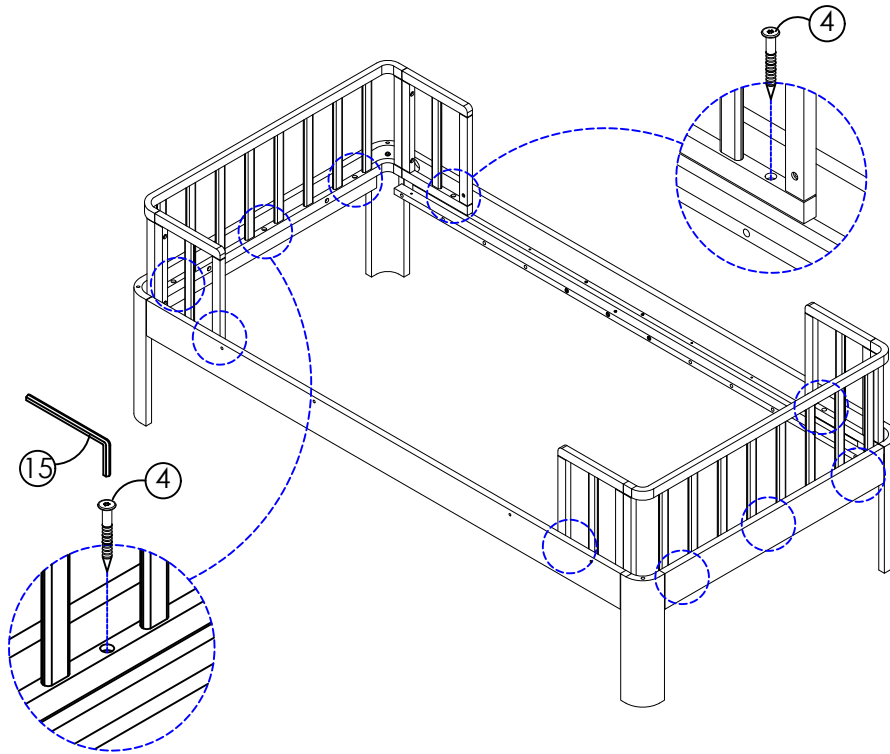

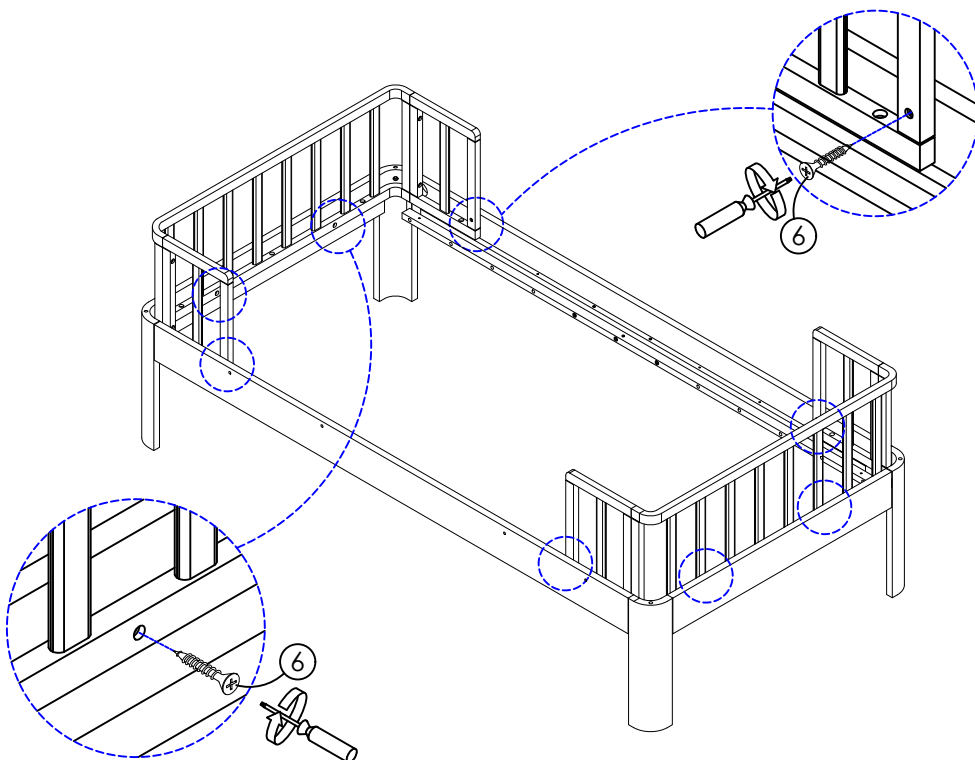

Step 18/ Étape 18/ Paso 18

⑥  x 8



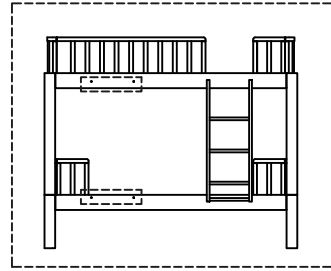
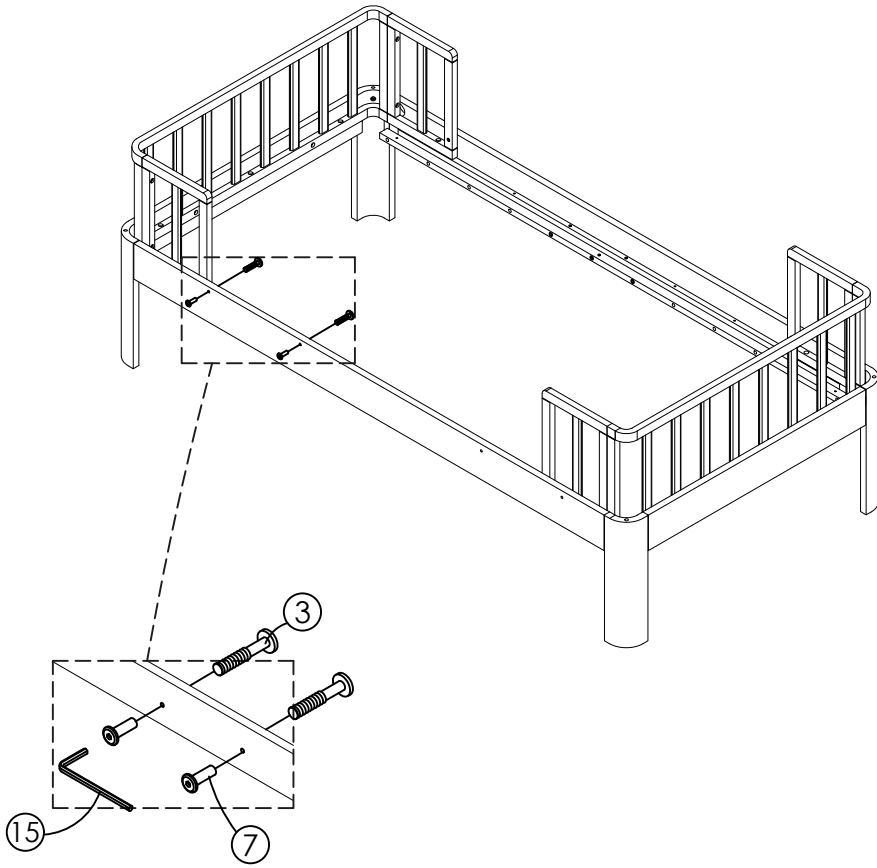

Step 19/ Étape 19/ Paso 19

- ③  x 2
- ⑦  x 2
- ⑮  x 1



Step 20/ Étape 20/ Paso 20

- ③  x 2
- ⑦  x 2
- ⑮  x 1

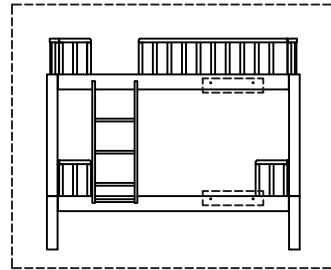
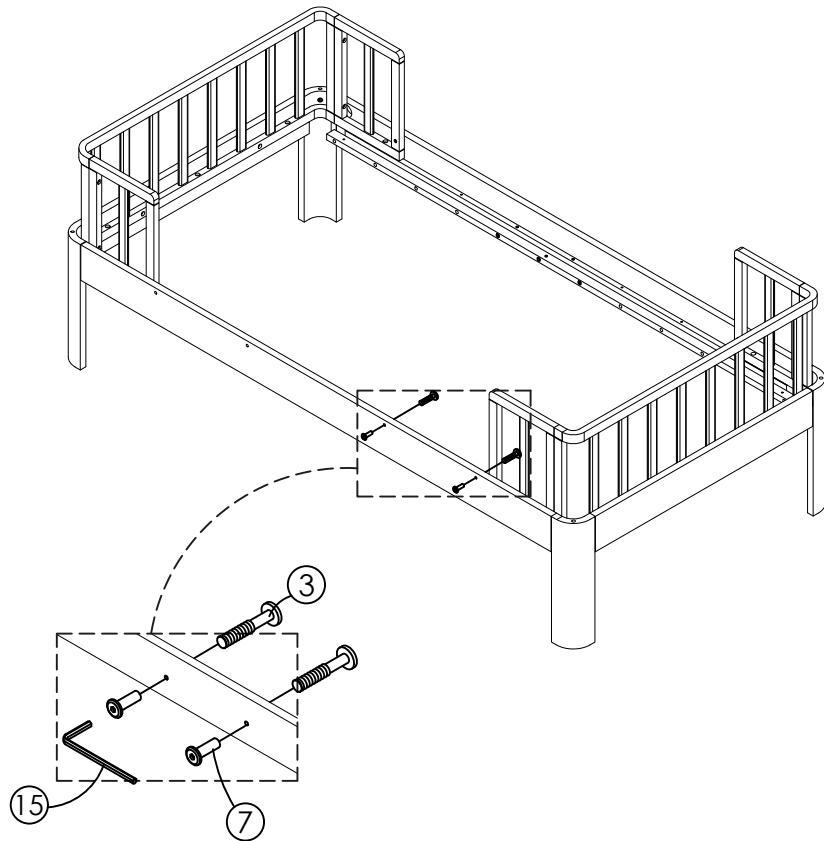

Step 21/ Étape 21/ Paso 21

⑥  x 18

⑤  x 8

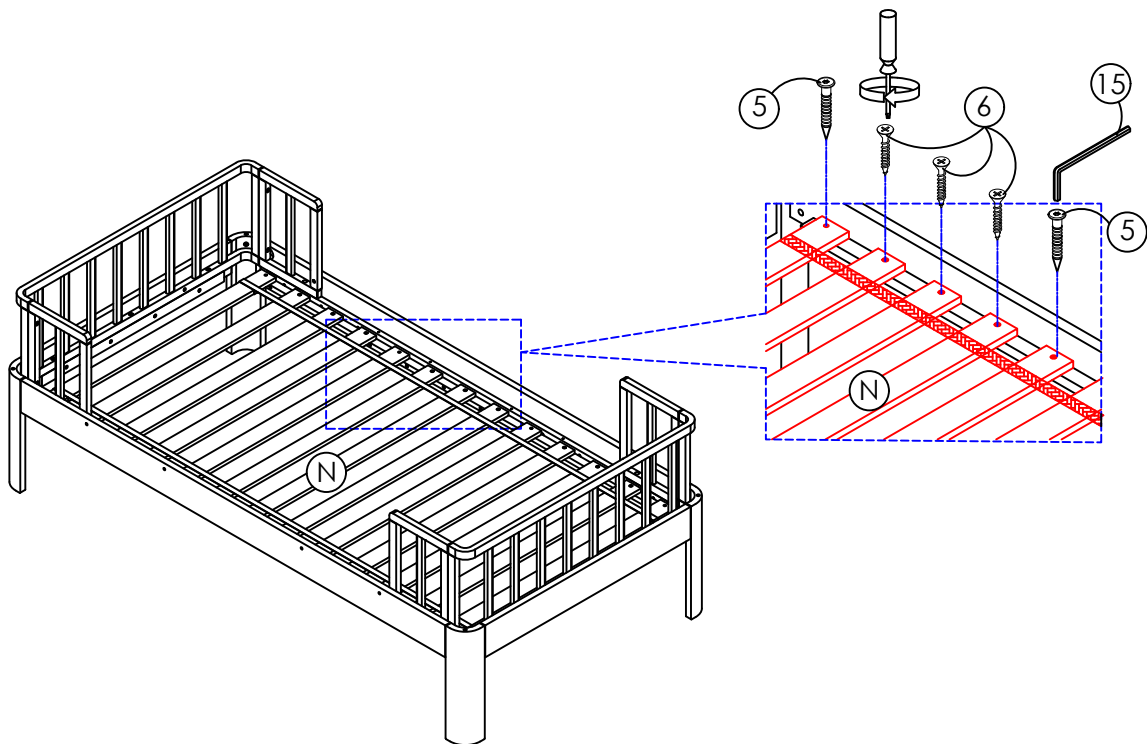

Step 22/ Étape 22/ Paso 22

⑩  x4

⑮  x1

③  x4

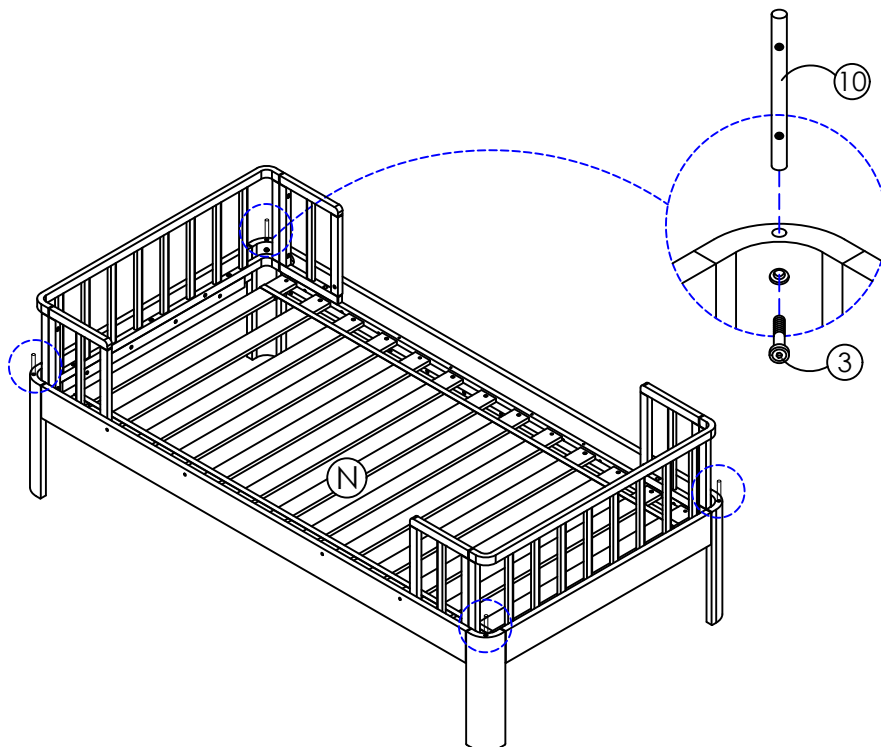



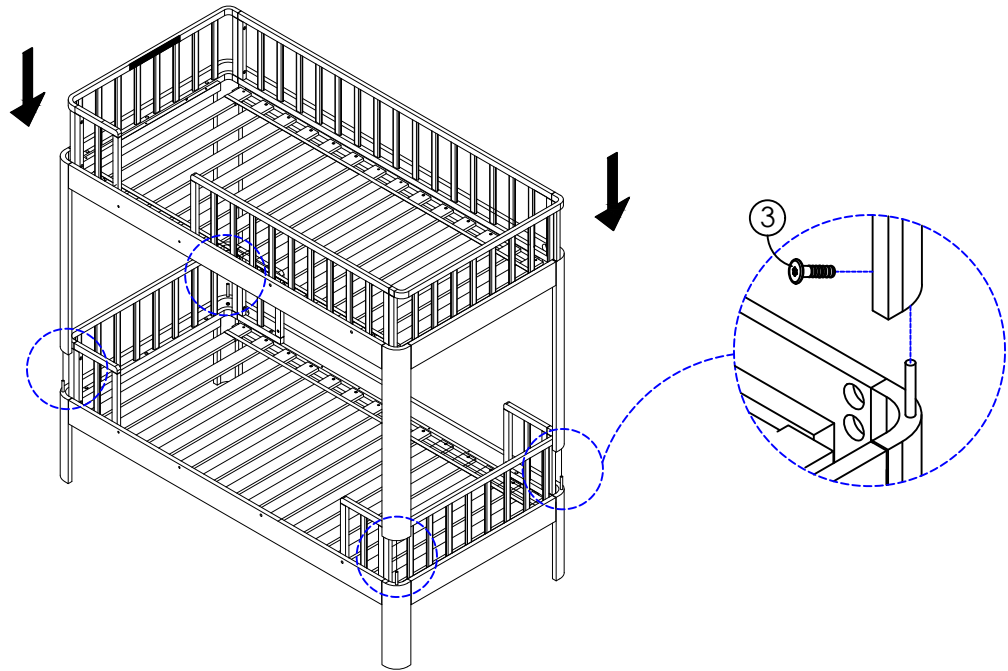

Step 23/ Étape 23/ Paso 23

- ⑮  x1
- ③  x4



Step 24/ Étape 24/ Paso 24

- ①  x 8
- ⑨  x 8
- ⑧  x 8
- ⑮  x 1

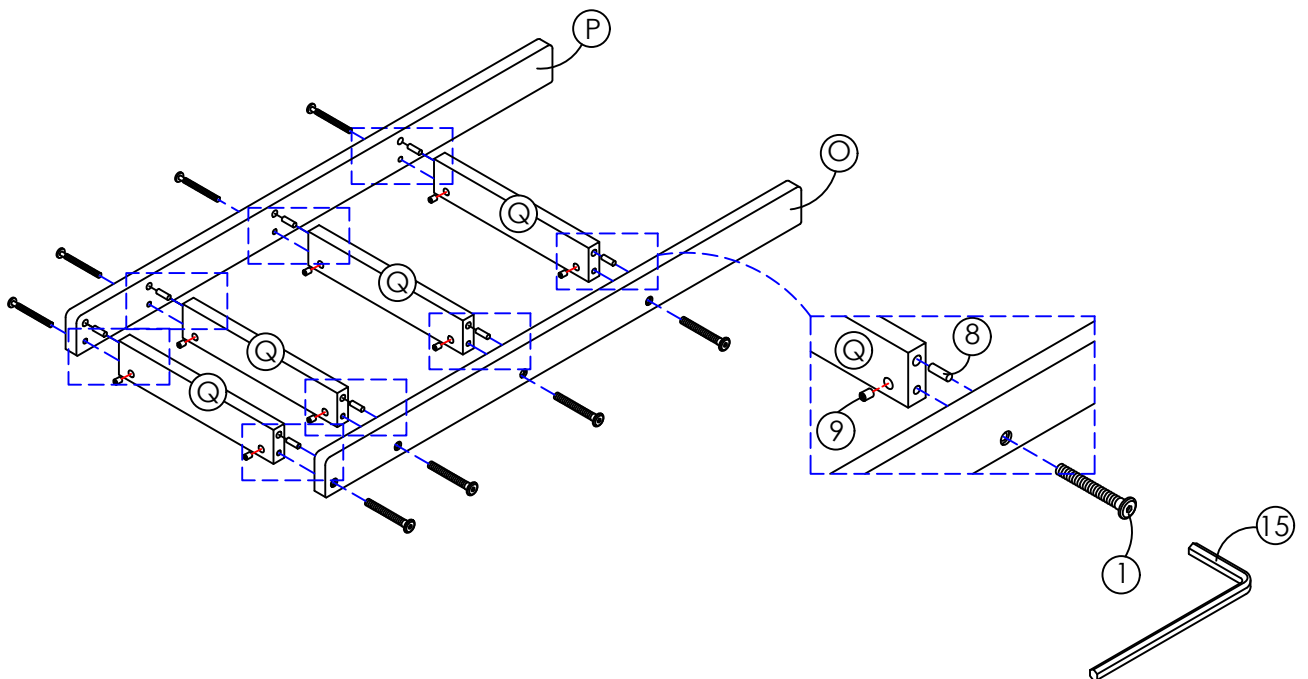

Step 25/ Étape 25/ Paso 25

- ⑮  x1
- ②  x4

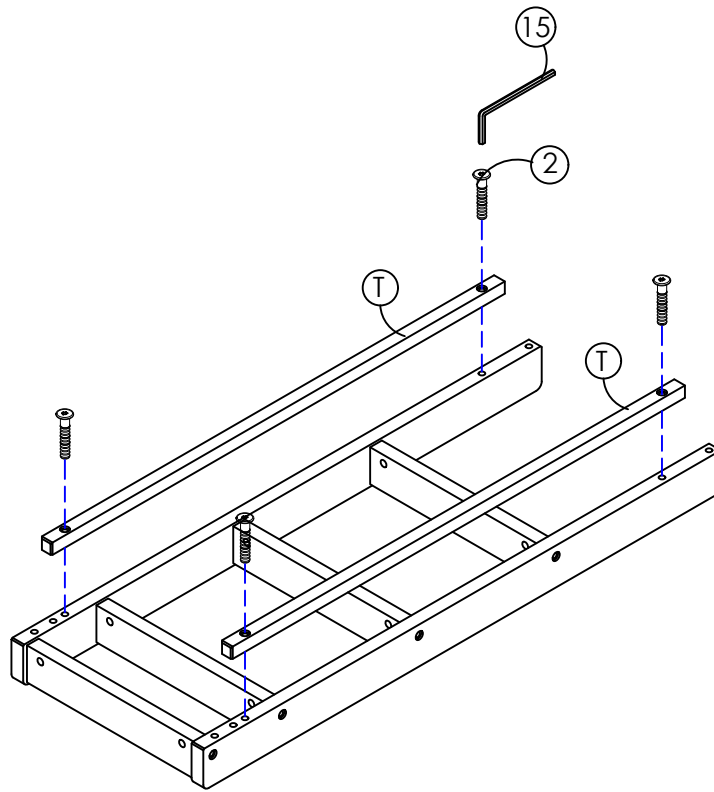

Step 26 Étape 26/ Paso 26

- ②  x4
- ⑮  x1

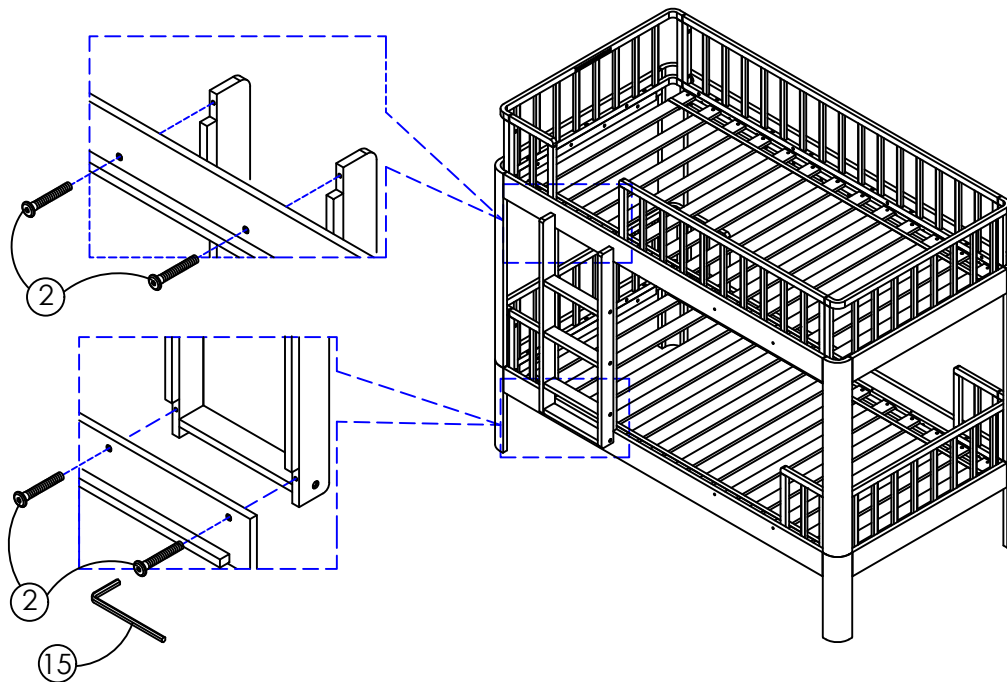

Step 27/ Étape 27/ Paso 27

**COMPLETE ASSEMBLY FOR BUNK BED
ENSEMBLE COMPLET POUR LIT SUPERPOSÉ
MONTAJE COMPLETO PARA LITERA**

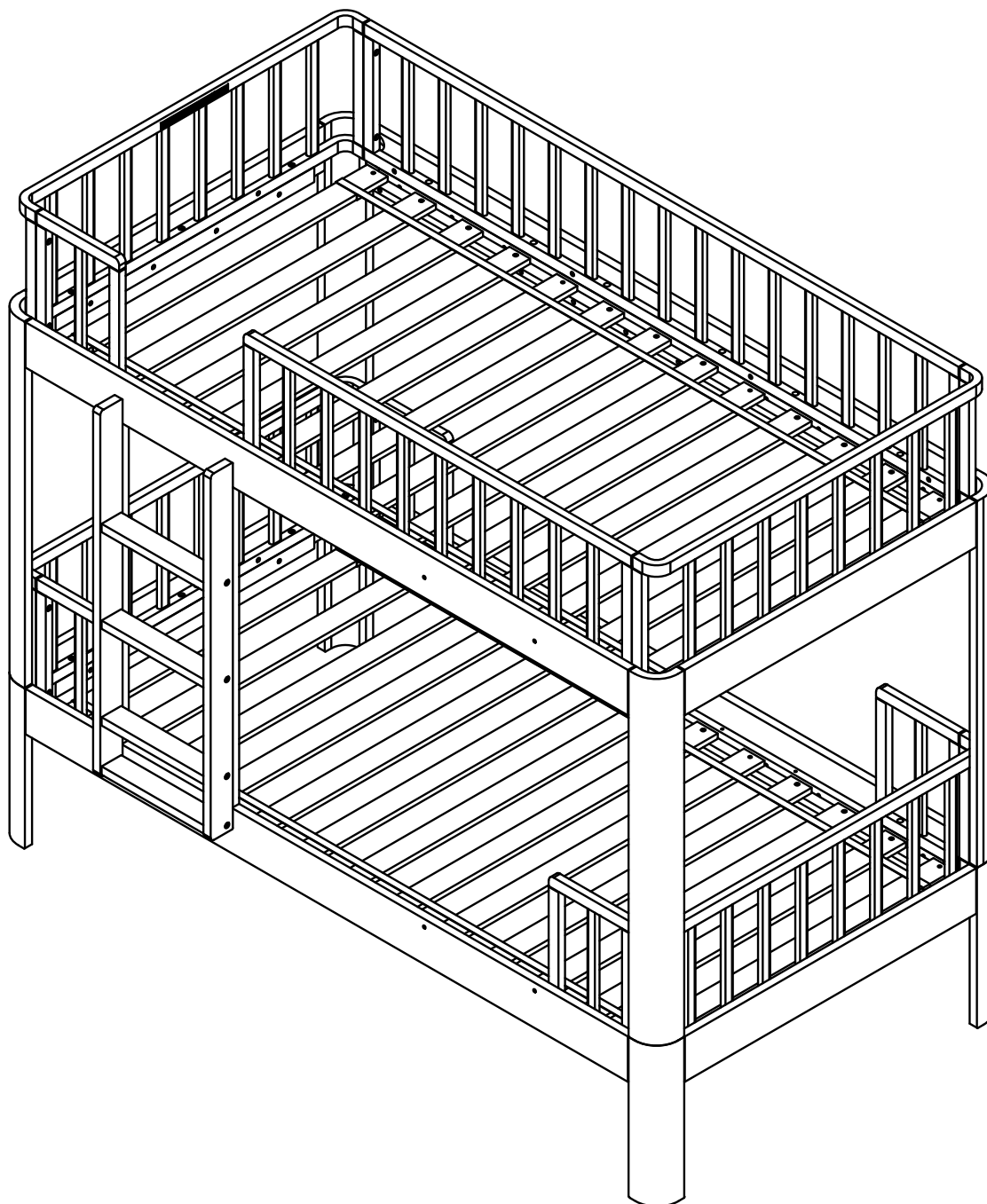

KIDS LOFT / PIGEONNIER POUR ENFANTS / LOFT INFANTIL

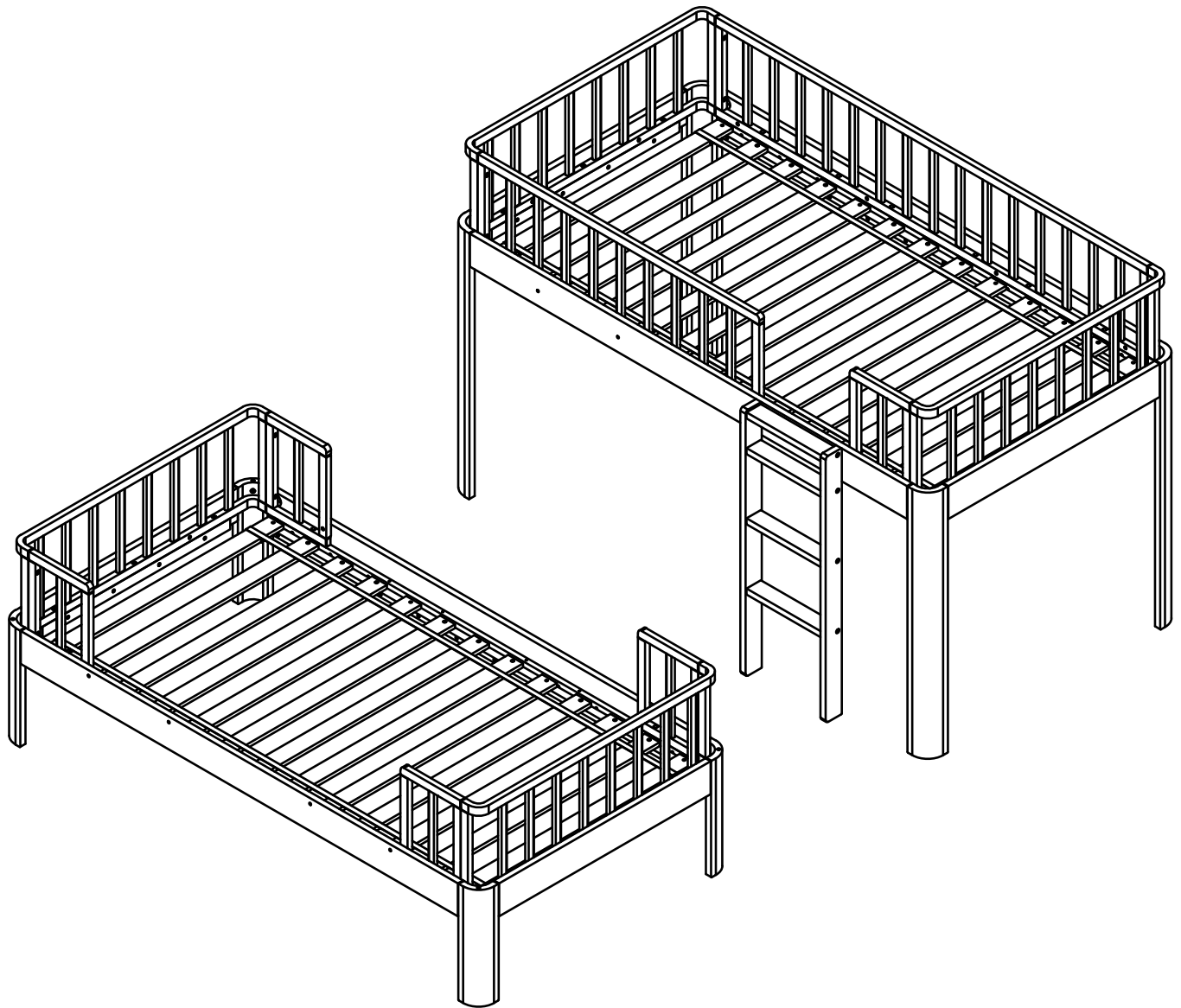

Identifying The Parts/Identification des pièces/ Identificación de piezas

ASSEMBLY TIPS

1. Remove hardware from box and sort by size.
2. Please check to see that all hardware and parts are present prior start of assembly.
3. Please follow attached instructions in the same sequence as numbered to assure fast and easy assembly.

WARNING!

1. Don't attempt to repair or modify part that are broken or defective. Please contact the store immediately.
2. This product is for home use only and not intended for commercial establishments.

RECOMENDACIONES DE ENSAMBLAJE

1. Retire el herraje de la caja y ordene por tamaño.
2. Por favor compruebe que todo el herraje y piezas estén listas antes del inicio del ensamble.
3. Por favor siga las instrucciones adjuntas en la misma secuencia numerada para asegurar un ensamblado rápido y fácil.

ADVERTENCIA!

1. No intente reparar o modificar si alguna pieza está rota o defectuosa. Por favor, póngase en contacto con la tienda de inmediato.
2. Este producto es para uso doméstico solamente y no destinado a establecimientos comerciales.

CONSEILS DE MONTAGE

1. Retirez le matériel de la boîte et de tri par taille.
2. Se il vous plaît vérifier que tout le matériel et les pièces sont présentes avant début de réunion .
3. Se il vous plaît suivre les instructions jointes dans la même séquence que numéroté pour assurer un montage rapide et facile .

ATTENTION!

1. À ne pas tenter de réparer ou de modifier une partie qui sont cassé ou défectueux. Se il vous plaît contactez immédiatement le magasin.
2. Ce produit est pour un usage domestique seulement et non destinés à des établissements commerciaux.



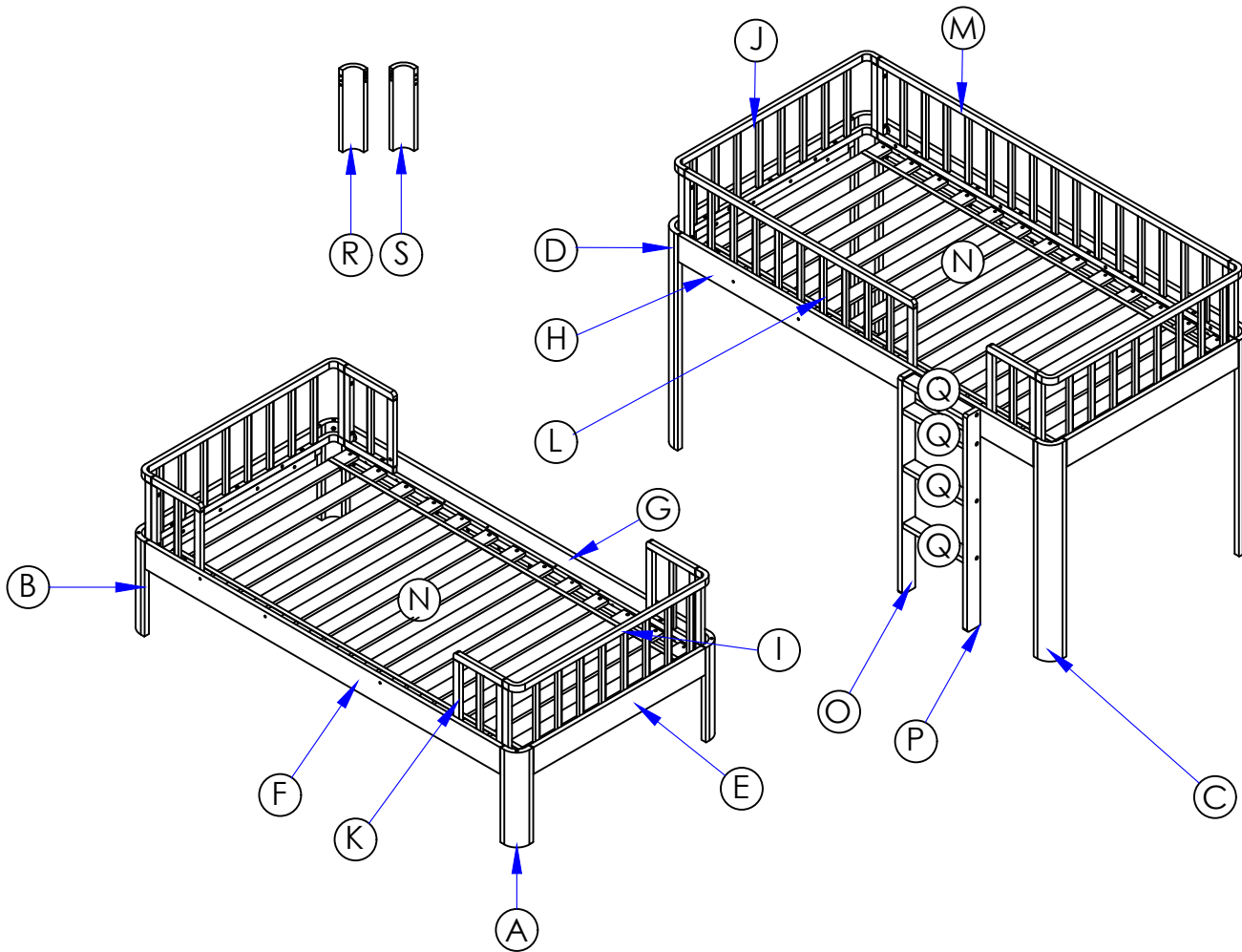











Identifying The Parts/Identification des pièces/ Identificación de piezas



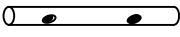

Part	Name Of Part List	Qty
A	Lower leg (Left rear & right front)	2pcs
B	Lower leg (Left front & right rear)	2pcs
C	Upper leg (Left rear & right front)	2pcs
D	Upper leg (Left front & right rear)	2pcs
E	Headboard/Footboard rail	4pcs
F	Lower front side rail	1pc
G	Upper & lower rear side rail	2pcs
H	Upper front side rail	1pc
I	Headboard/Footboard frame	2pcs
J	Headboard/Footboard frame with sticker	2pcs

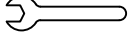
Part	Name Of Part List	Qty
K	Short guard frame	5pcs
L	Upper Front Guard Frame	1pc
M	Upper Rear Guard Frame	1pc
N	Slat	2sets
O	Right ladder rail	1pc
P	Left ladder rail	1pc
Q	Ladder stretcher	4pcs
R	Extra Lower Leg (Left Rear & Right Front)	2pcs
S	Extra Lower Leg (Right Rear & Left Front)	2pcs
T	Support rail	2pcs

HARDWARE PACK



NO.	DESCRIPTION		DIMENSION	QTY
1	Bolts		M6 x 60mm	8 pcs
2	Bolts		M6 x 40mm	24 pcs
3	Bolts		M6 x 16mm	16 pcs
4	Bolts		M6 x 40mm	27 pcs
5	Bolts		M6 x 28mm	16 pcs
6	Wood Screw		M4.0 x 28mm	56 pcs
7	JCN Nut		M6	8 pcs
8	Wood Dowel		Ø10 x 30mm	40 pcs
9	Barrel Nut		M6 x 13mm	8 pcs
10	Metal Pin With Hole		Ø10 x 100mm	4 pcs
11	Hanger Bolts		M8 x 60mm	24 pcs
12	H/M Washer		M8	24 pcs
13	H/M Nut		M8	24 pcs
14	Wrench		M8	1 pc
15	Allen Key		M4	1 pc

Step 1/ Étape 1/ Paso 1

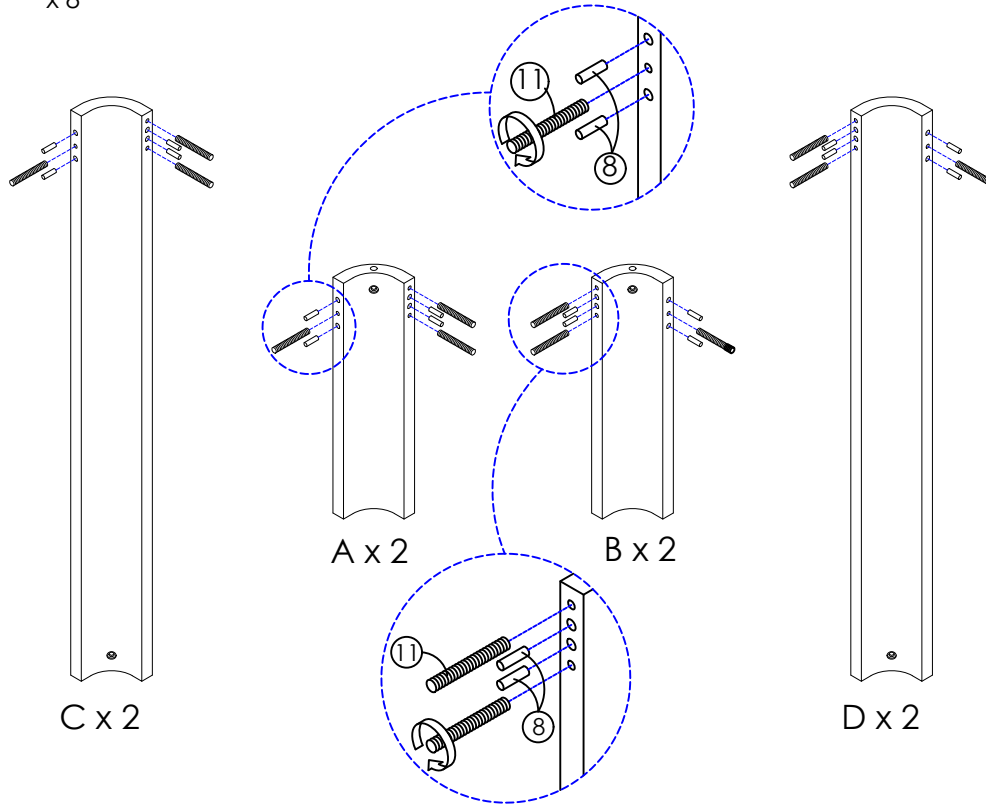
- ①  x 8
- ⑨  x 8



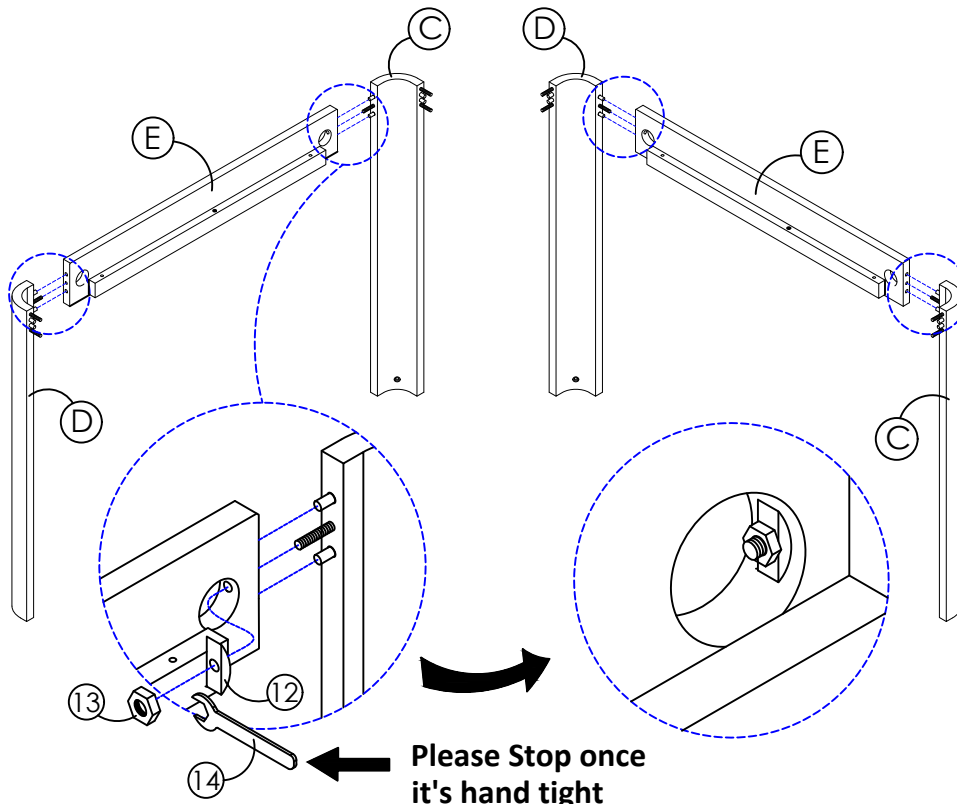

Step 2/ Étape 2/ Paso 2

- ⑫  x 4
- ⑬  x 4
- ⑭  x 1



Step 3/ Étape 3/ Paso 3

- ⑫  x 8
- ⑬  x 8
- ⑭  x 1

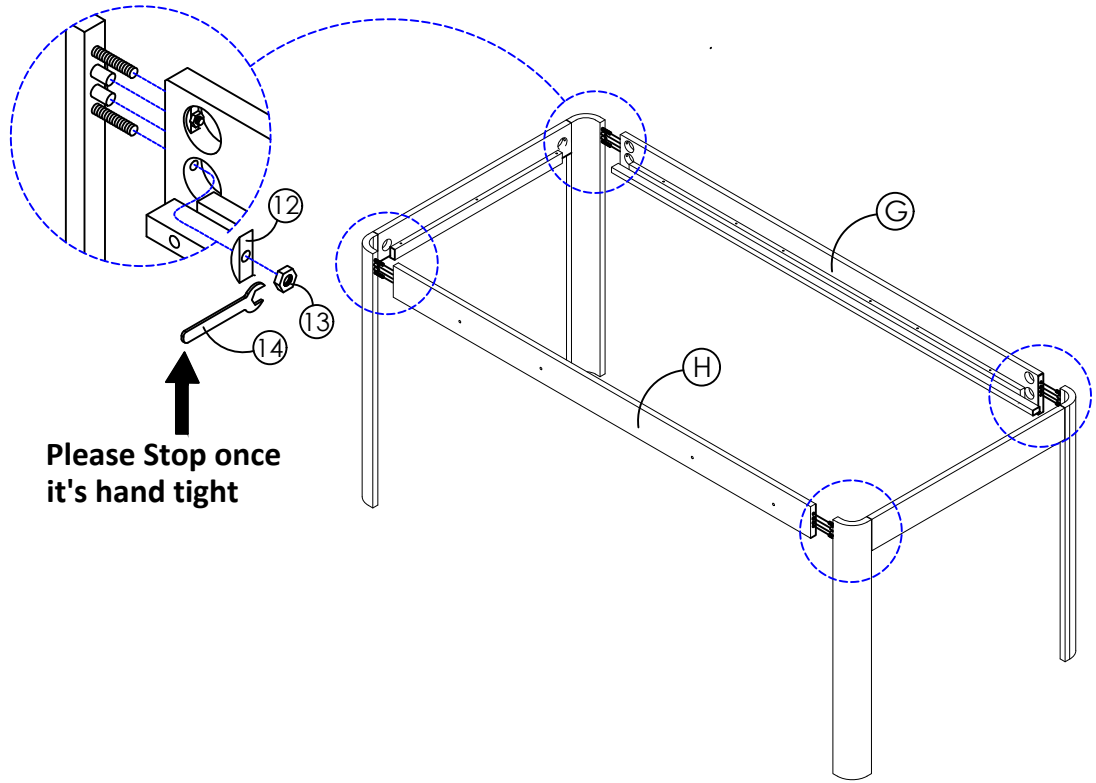



Please Stop once it's hand tight

Step 4/ Étape 4/ Paso 4

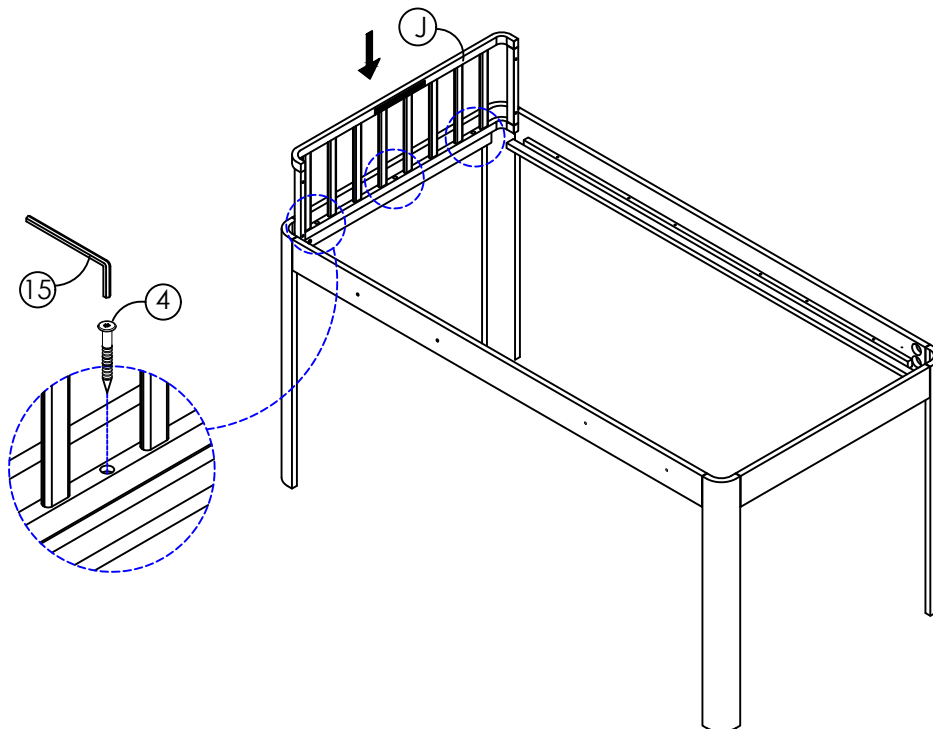
- ④  x 3
- ⑮  x 1



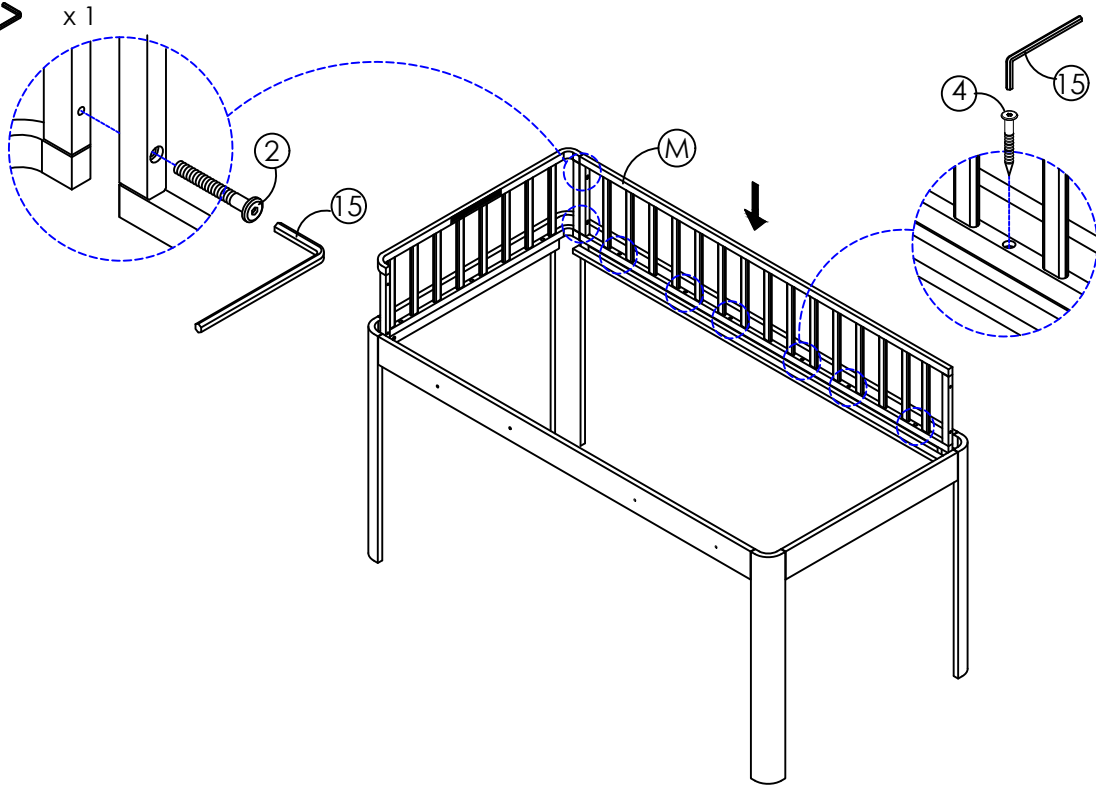

Step 5/ Étape 5/ Paso 5

- ②  x 2
- ④  x 6
- ⑮  x 1



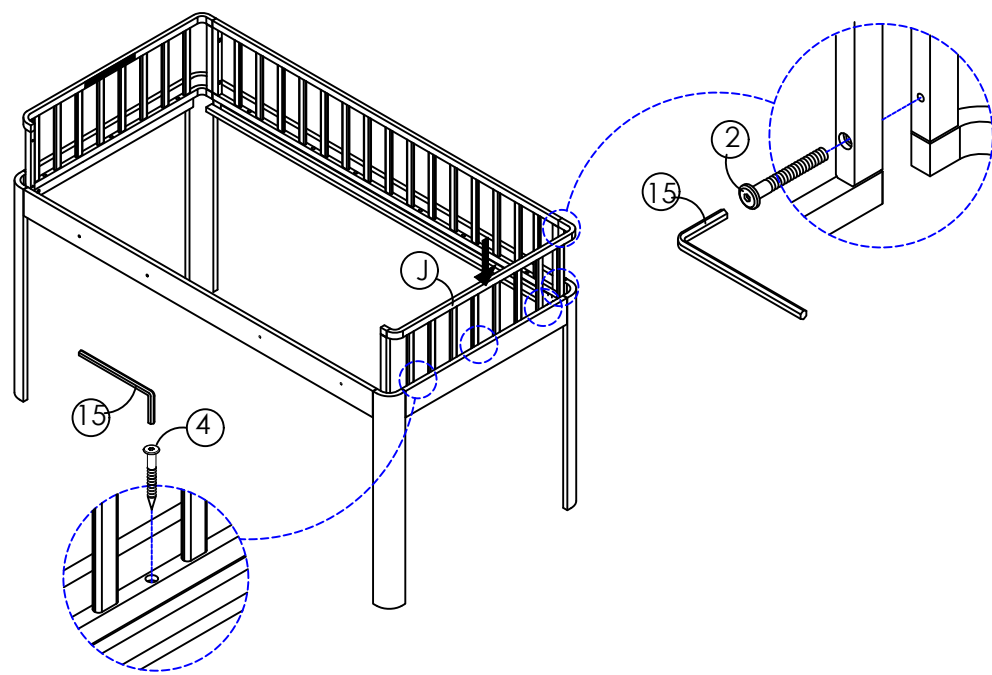

Step 6/ Étape 6/ Paso 6

- ②  x 2
- ④  x 3
- ⑮  x 1



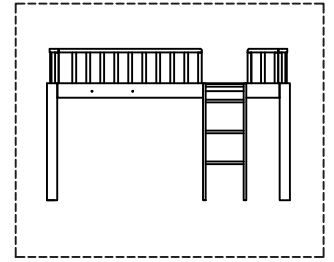
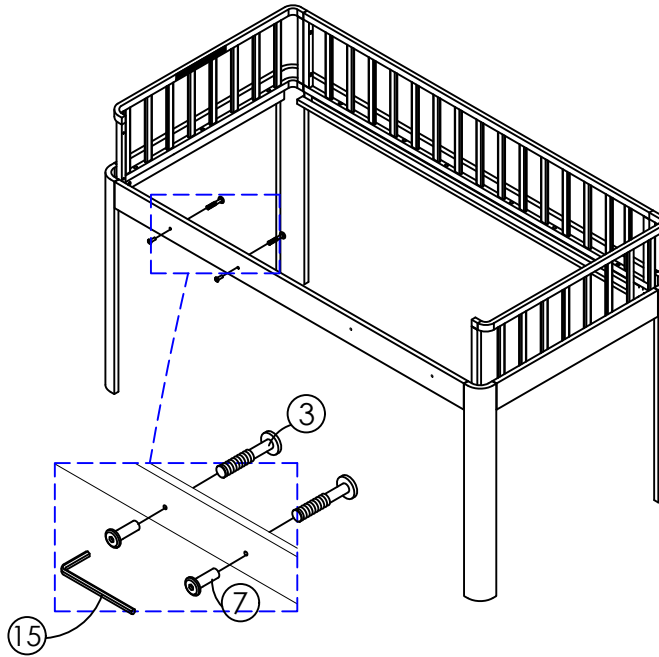

Step 7/ Étape 7/ Paso 7

- ③  x 2
- ⑦  x 2
- ⑮  x 1



Step 8/ Étape 8/ Paso 8

- ②  x 4
- ④  x 6
- ⑮  x 1

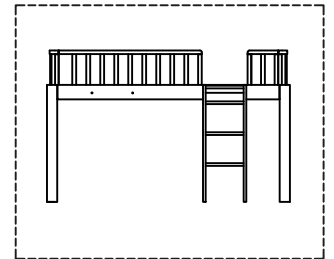
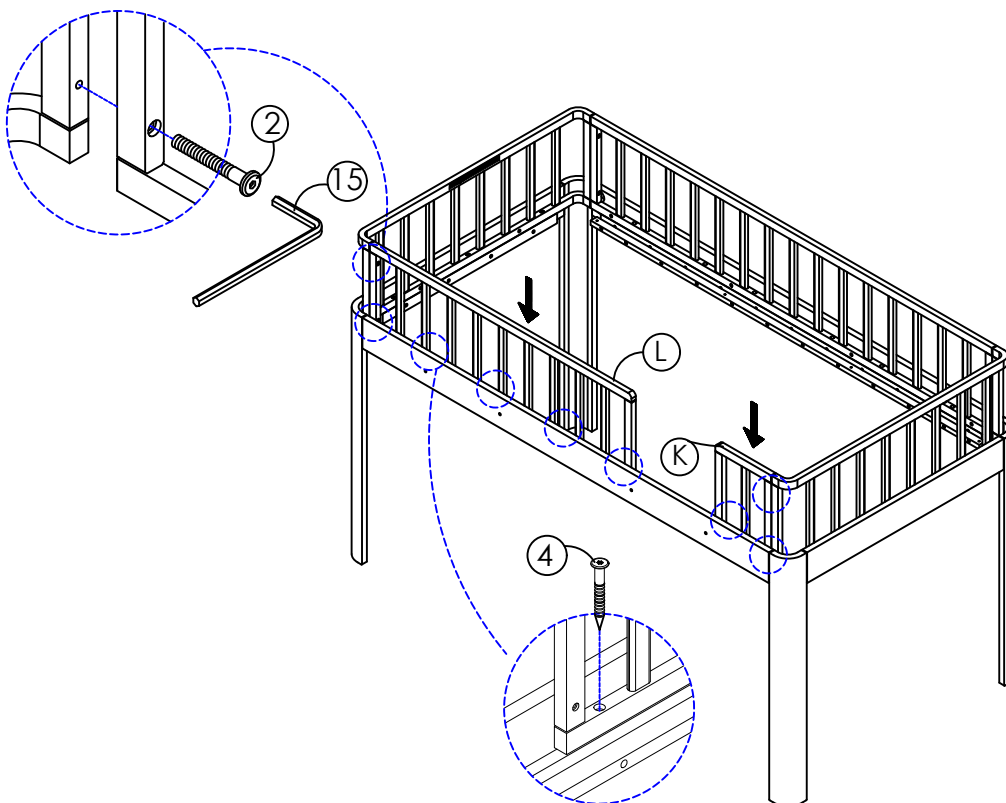

Step 9/ Étape 9/ Paso 9

⑥  x 12

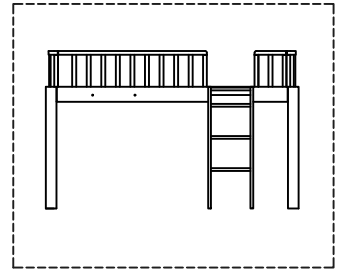
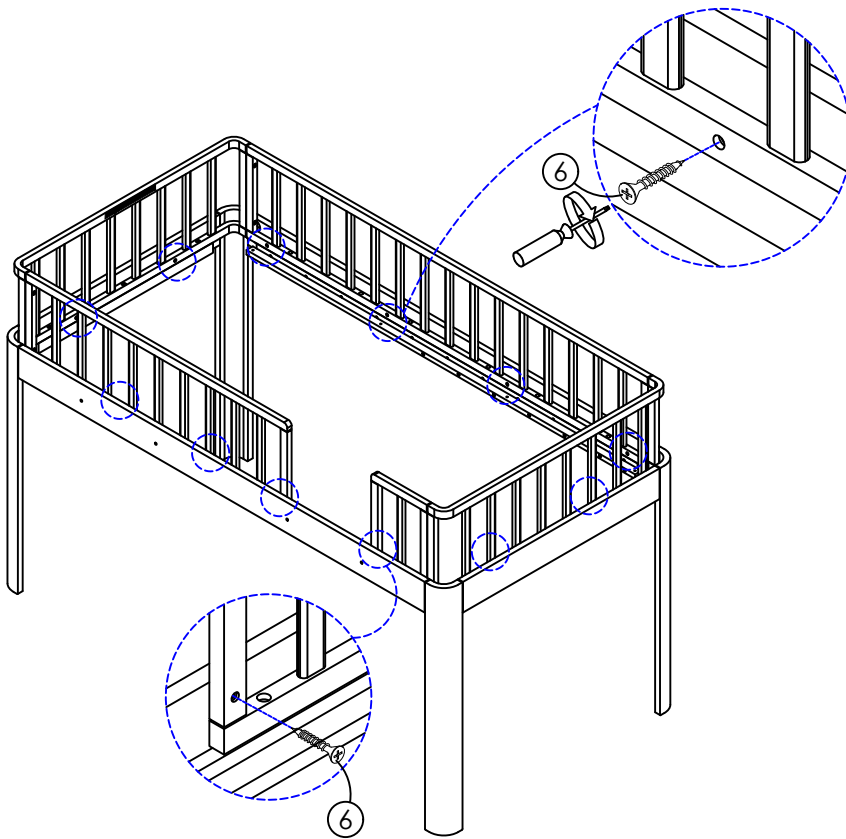

Step 10/ Étape 10/ Paso 10



③  x 2

⑦  x 2

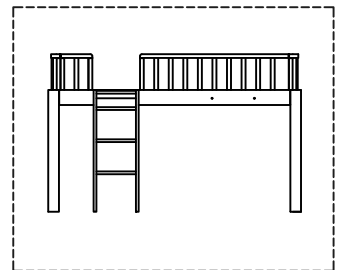
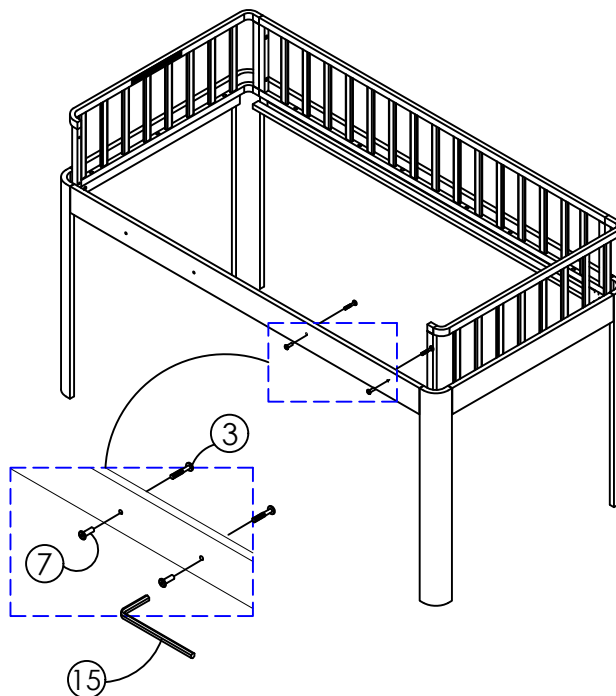
⑮  x 1



Step 11/ Étape 11/ Paso 11

- ②  x 4
- ④  x 6
- ⑮  x 1

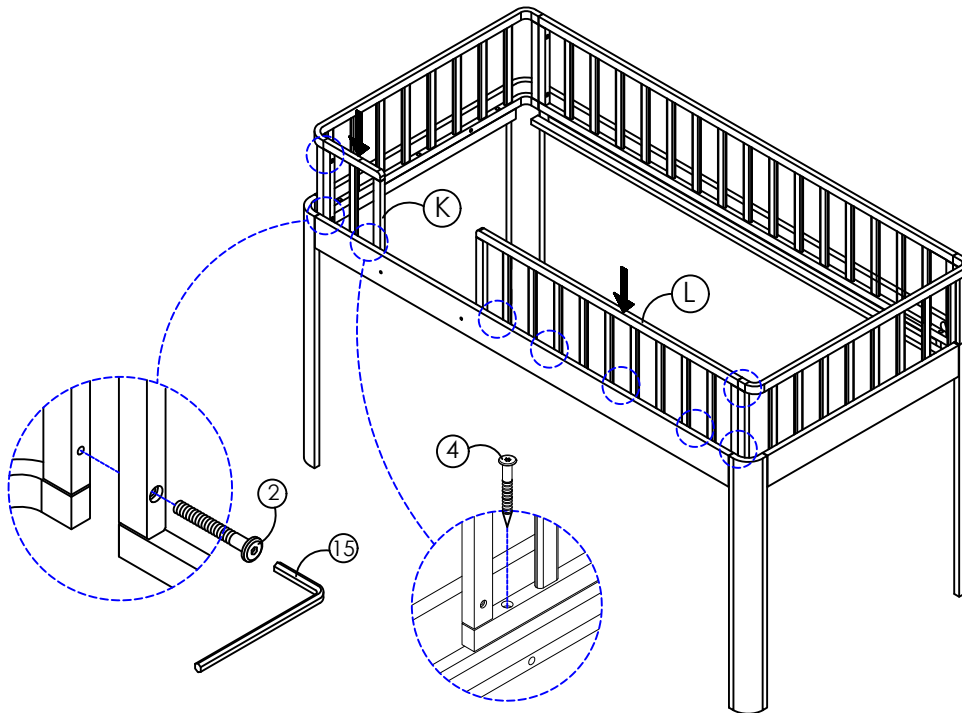
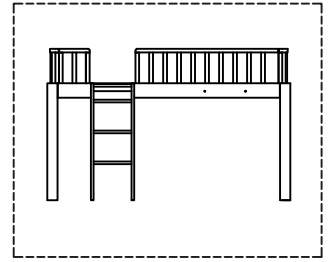

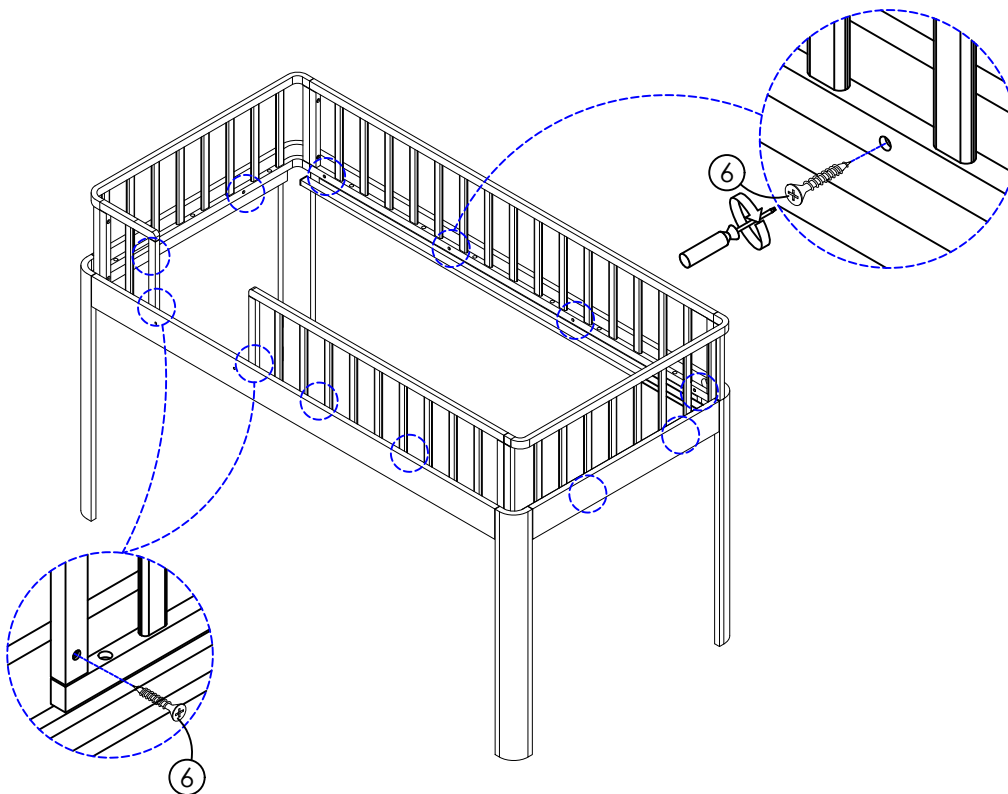
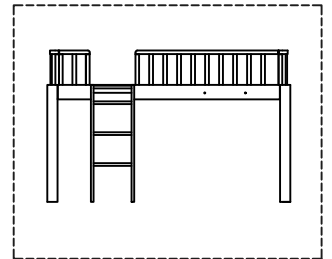

Step 12/ Étape 12/ Paso 12

- ⑥  x 12





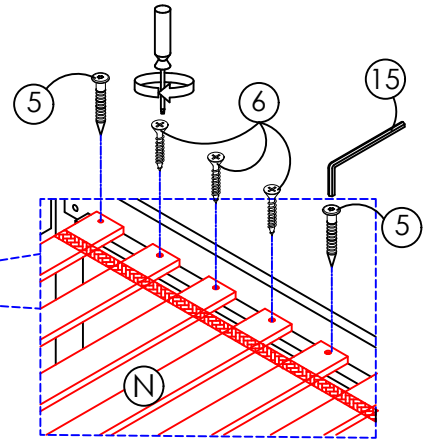
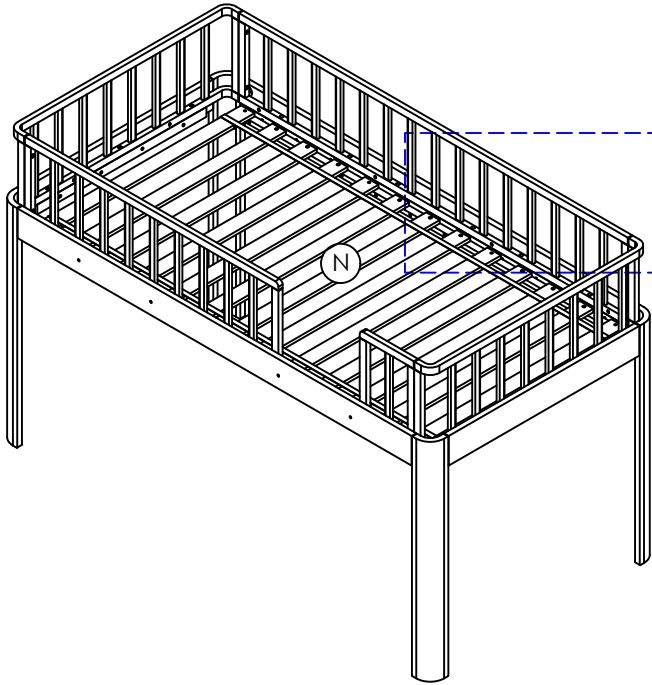

Step 13/ Étape 13/ Paso 13

- ⑥  x 18
- ⑤  x 8
- ⑮  x 1



Step 14/ Étape 14/ Paso 14

- ①  x 8
- ⑨  x 8
- ⑧  x 8
- ⑮  x 1

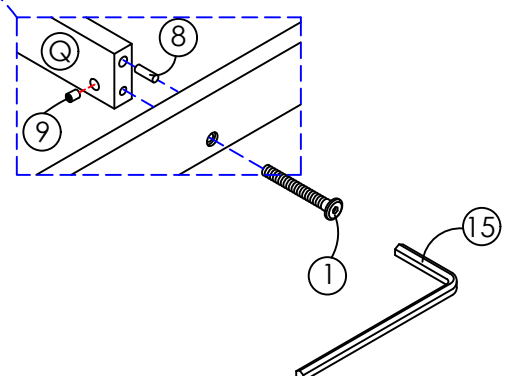
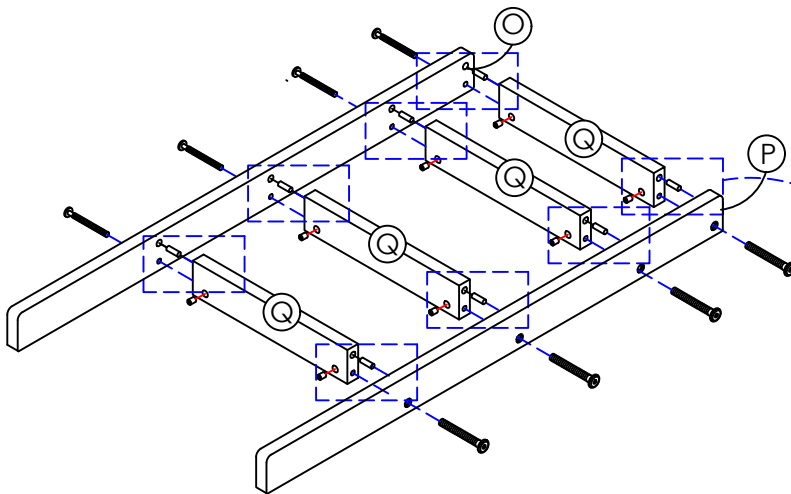

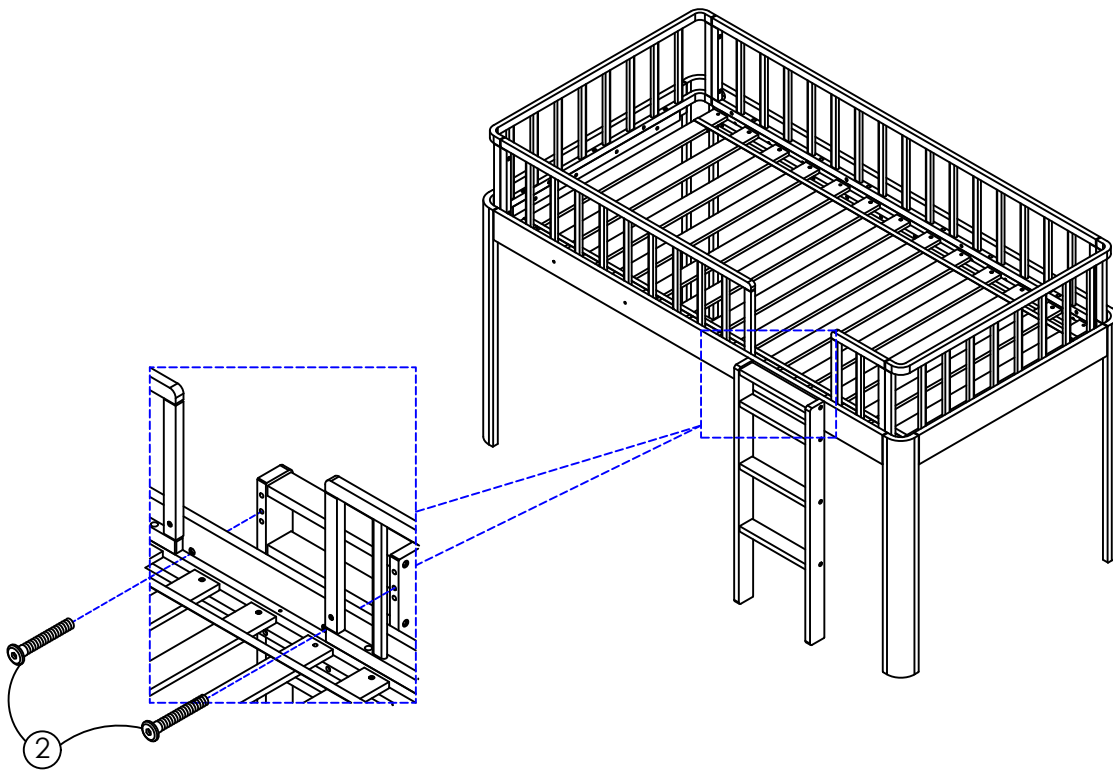

Step 15/ Étape 15/ Paso 15

- ⑮  x1
- ②  x2



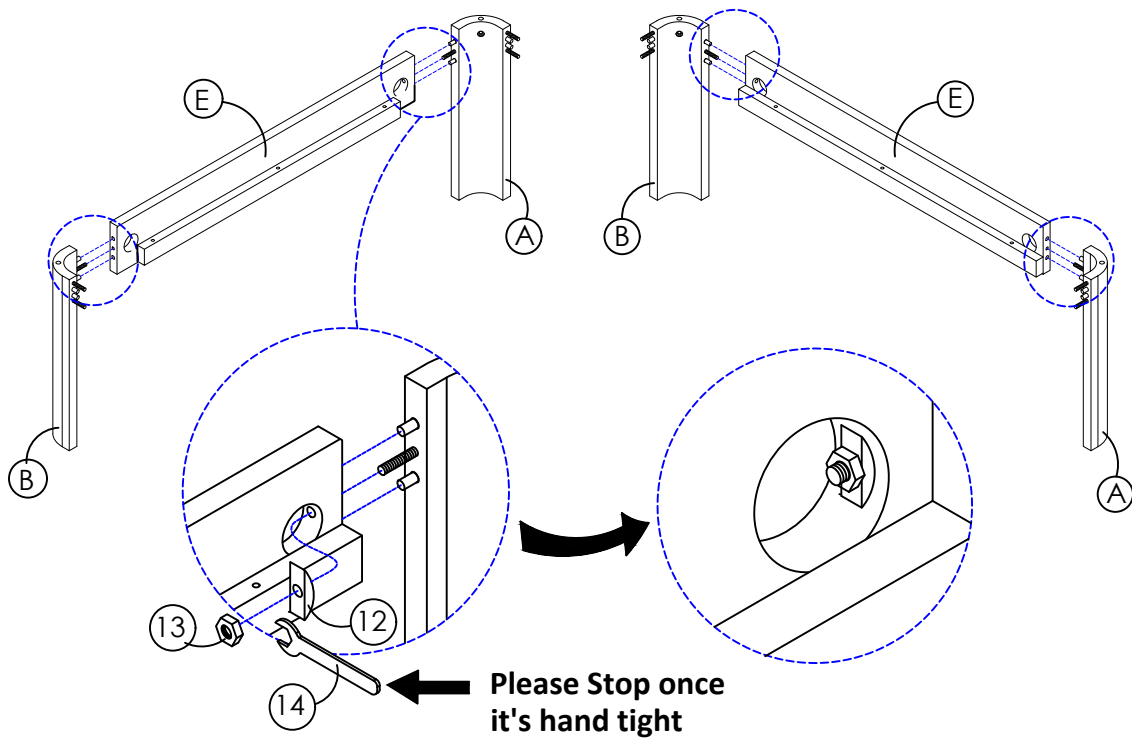

Step 16/ Étape 16/ Paso 16

- ⑫  x 4
- ⑬  x 4
- ⑭  x 1



Step 17/ Étape 17/ Paso 17

- ⑫  x 8
- ⑬  x 8
- ⑭  x 1

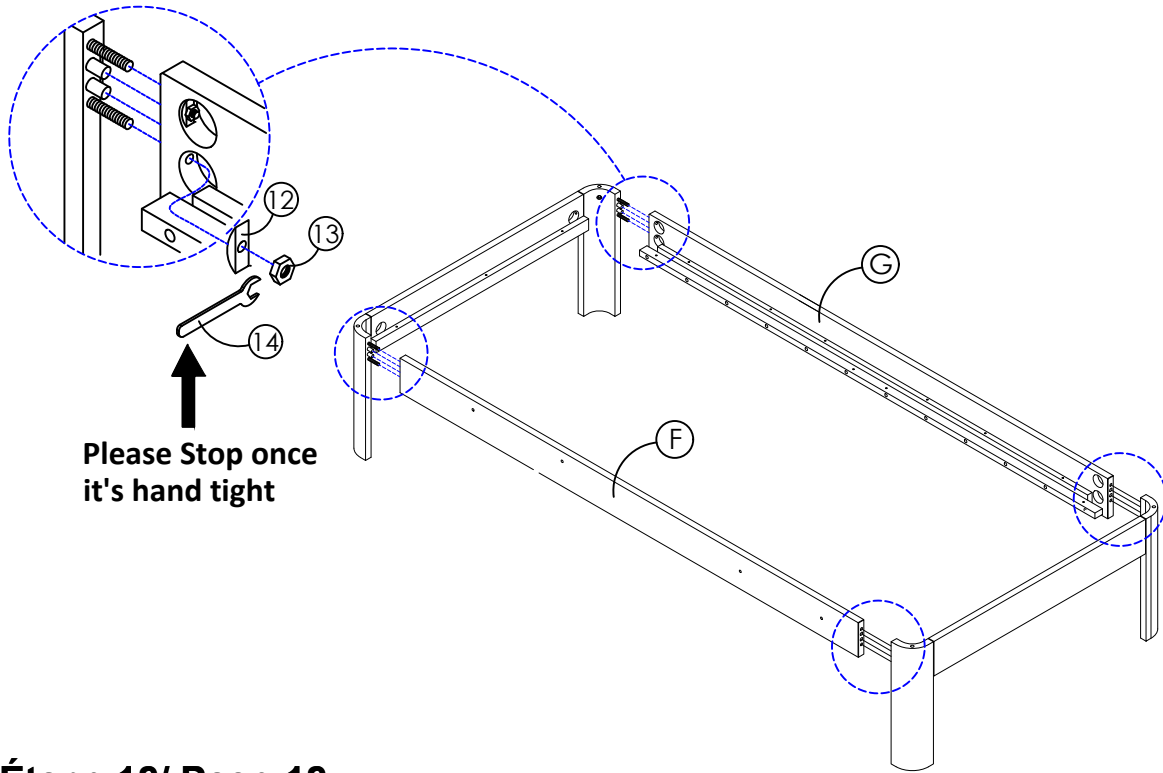

Please Stop once it's hand tight

Step 18/ Étape 18/ Paso 18

- ②  x 8
- ⑮  x 1

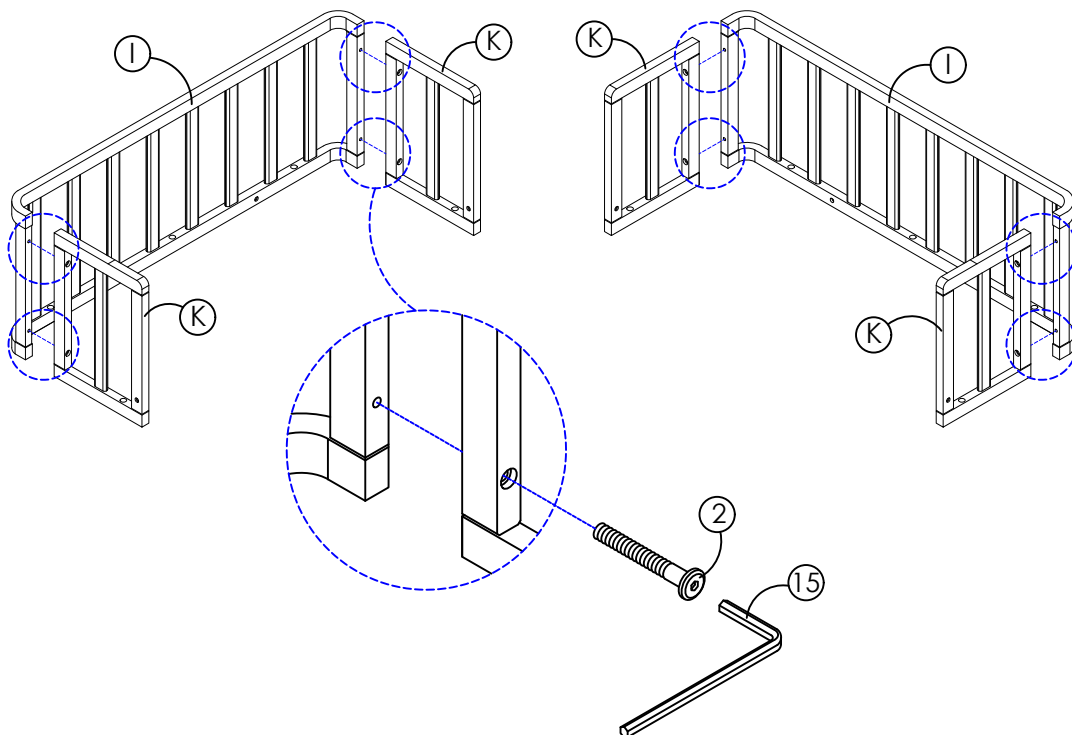

Step 19/ Étape 19/ Paso 19

④  x 10

⑮  x 1

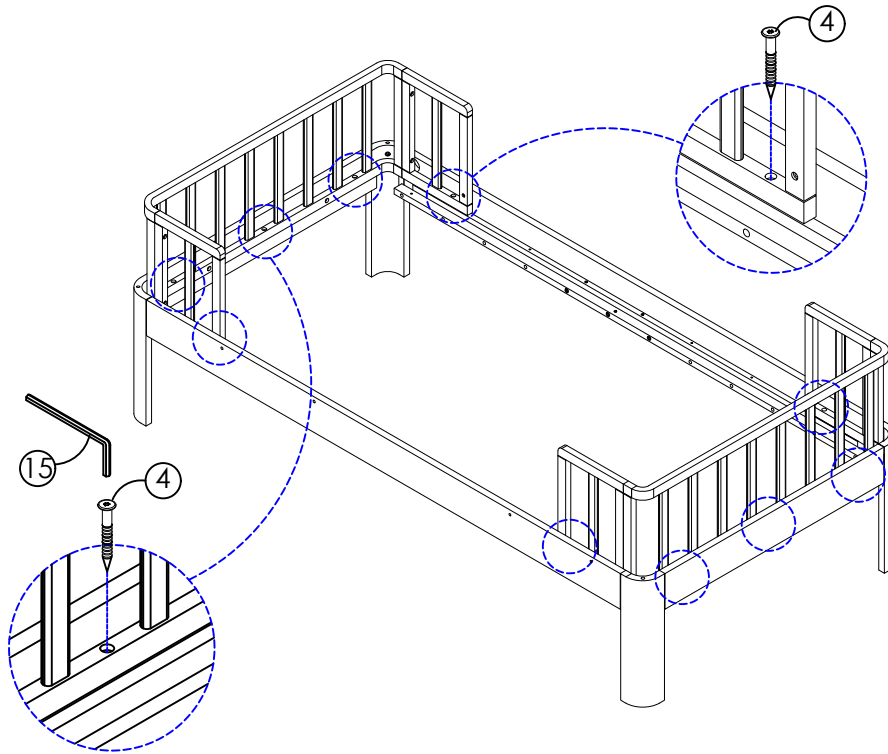

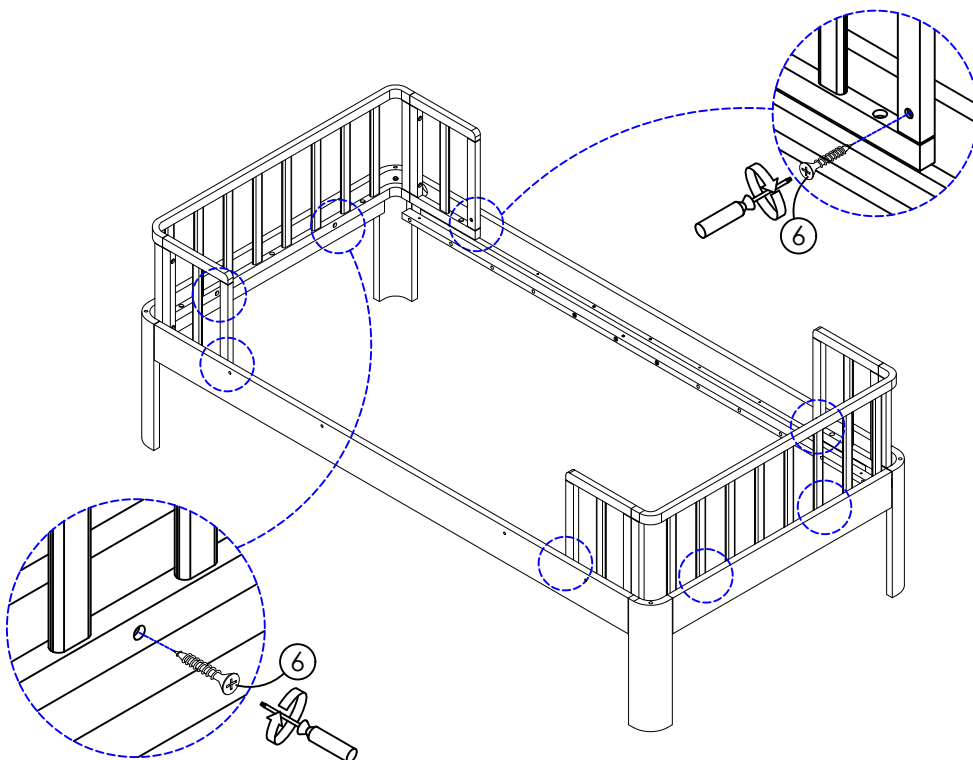

Step 20/ Étape 20/ Paso 20

⑥  x 8



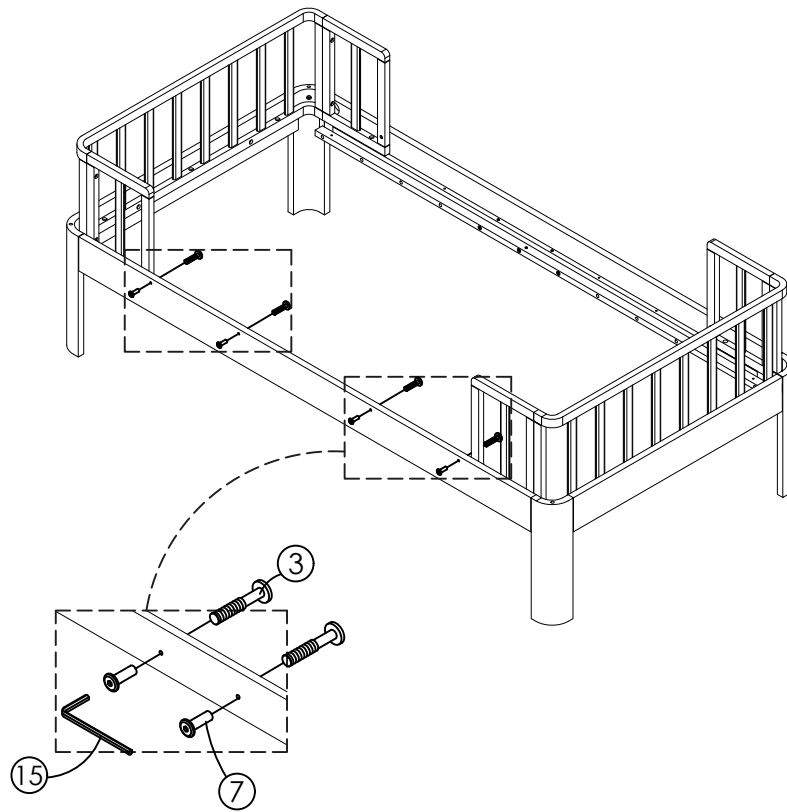

Step 21/ Étape 21/ Paso 21

- ③  x 4
- ⑦  x 4
- ⑮  x 1



Step 22/ Étape 22/ Paso 22

- ⑥  x 18
- ⑤  x 8
- ⑮  x 1

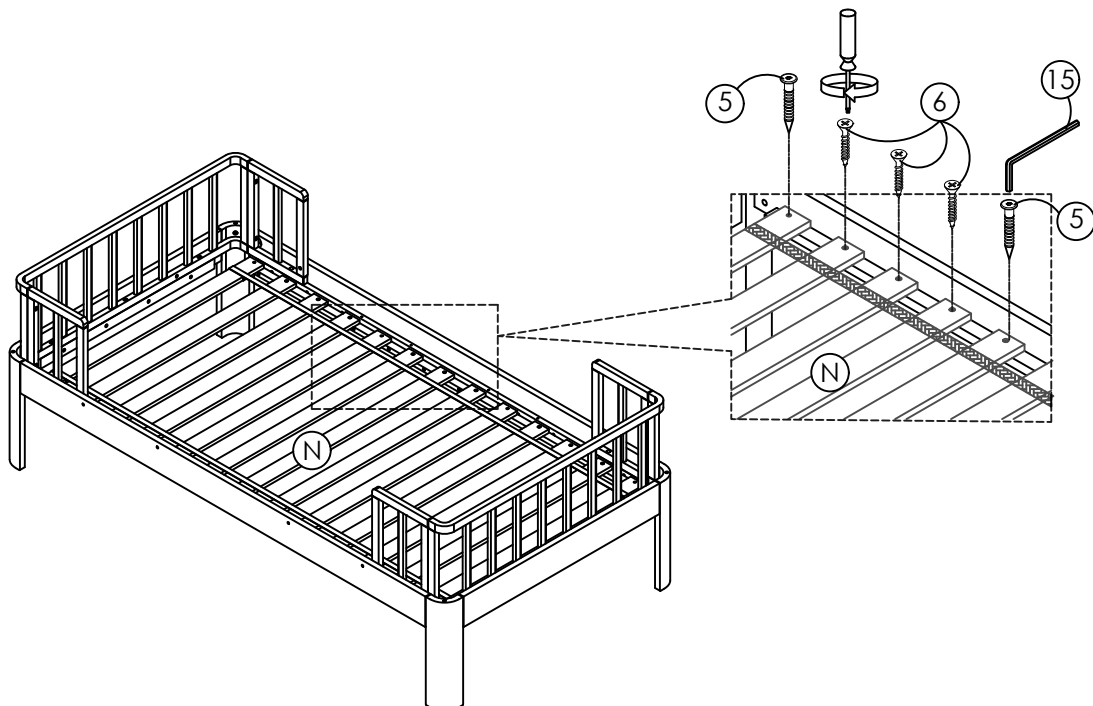

Step 23/ Étape 23/ Paso 23

COMPLETE ASSEMBLY FOR KIDS LOFT

ASSEMBLAGE COMPLET POUR LES ENFANTS LOFT

MONTAJE COMPLETO PARA BUHARDILLA INFANTIL

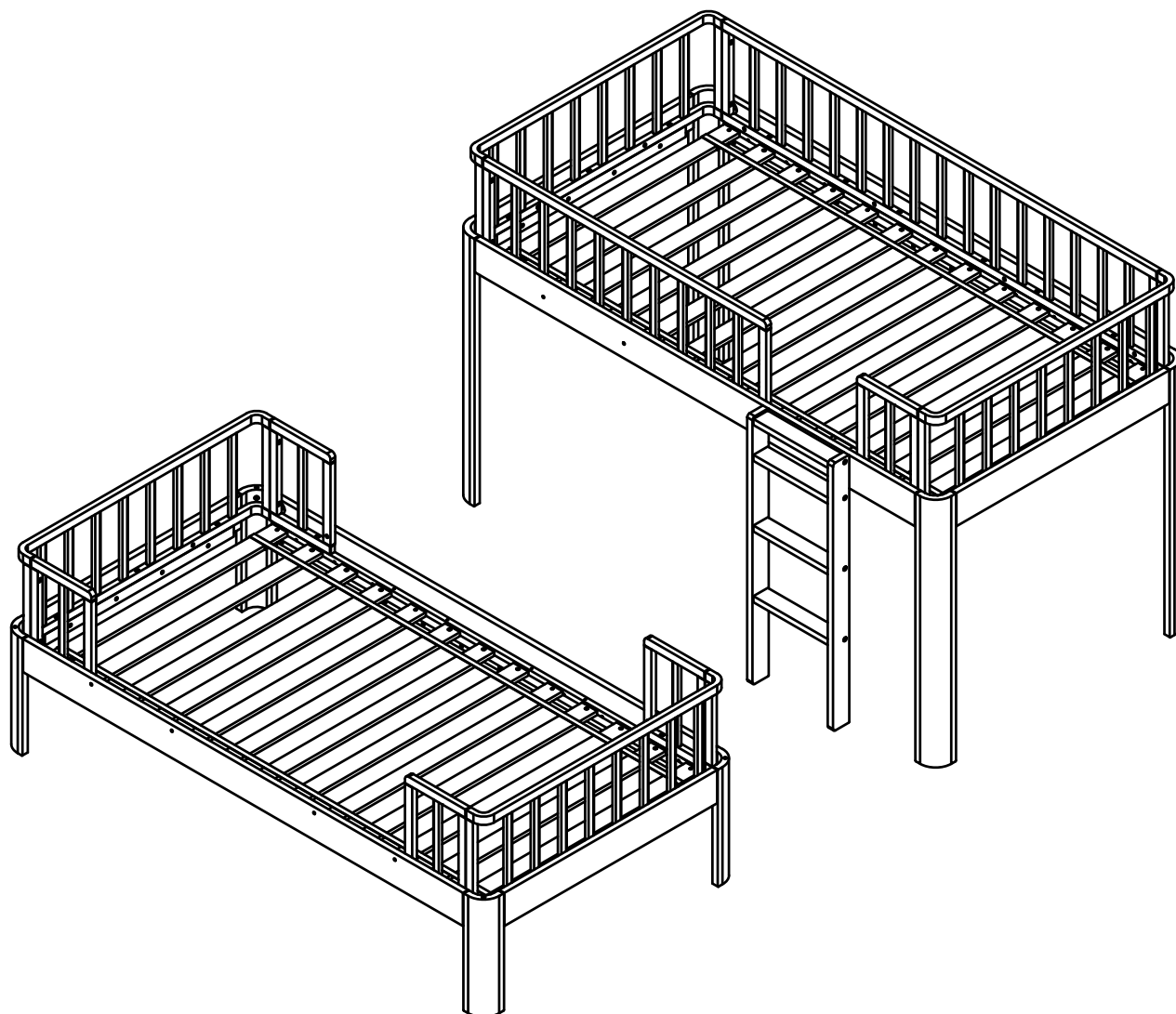

SINGLE BED & DAY BED / LIT SIMPLE ET LIT DE JOUR / CAMA INDIVIDUAL Y CAMA DE DÍA

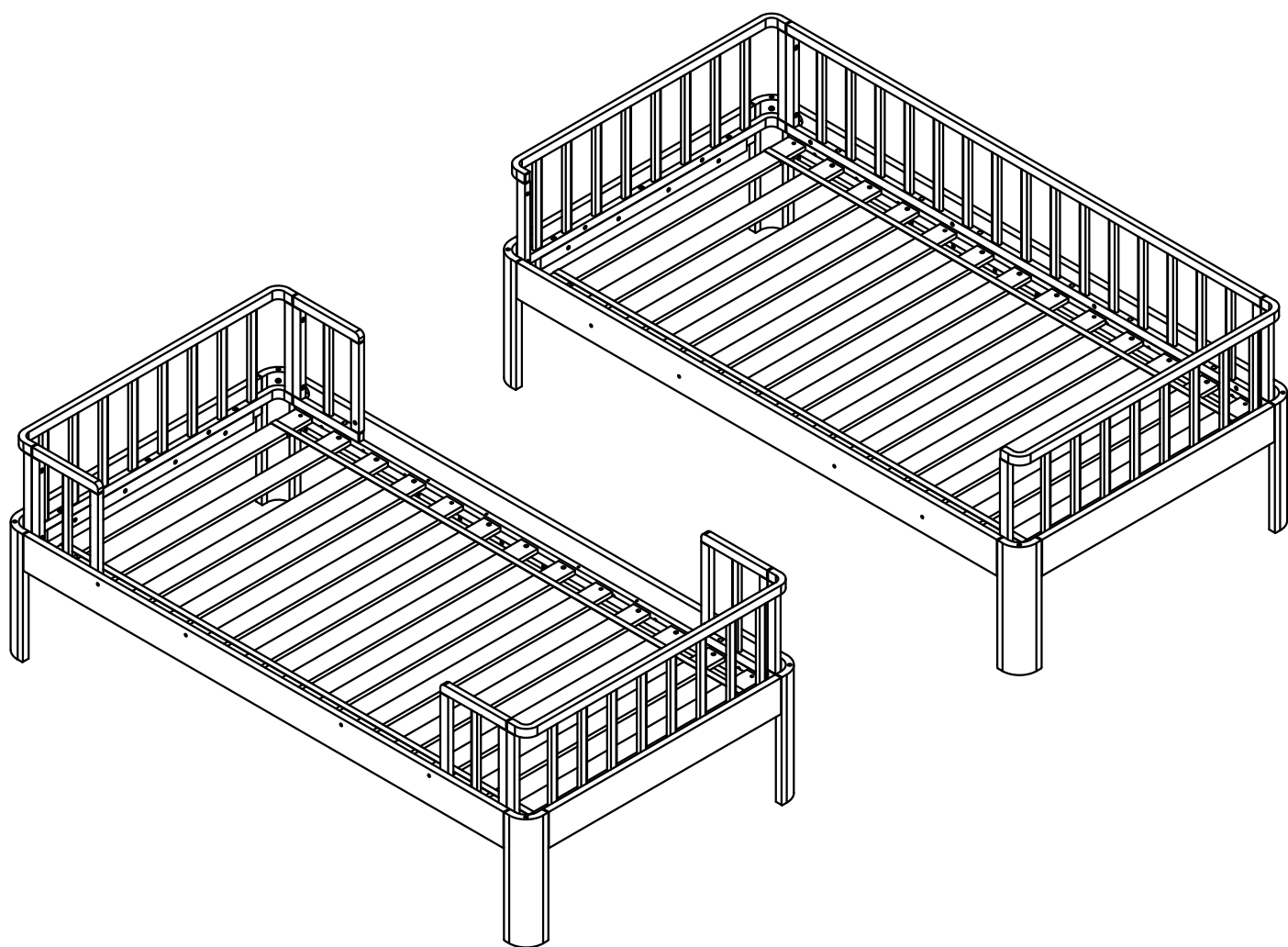

Identifying The Parts/Identification des pièces/ Identificación de piezas

ASSEMBLY TIPS

1. Remove hardware from box and sort by size.
2. Please check to see that all hardware and parts are present prior start of assembly.
3. Please follow attached instructions in the same sequence as numbered to assure fast and easy assembly.

WARNING!

1. Don't attempt to repair or modify part that are broken or defective. Please contact the store immediately.
2. This product is for home use only and not intended for commercial establishments.

RECOMENDACIONES DE ENSAMBLAJE

1. Retire el herraje de la caja y ordene por tamaño.
2. Por favor compruebe que todo el herraje y piezas estén listas antes del inicio del ensamble.
3. Por favor siga las instrucciones adjuntas en la misma secuencia numerada para asegurar un ensamblado rápido y fácil.

ADVERTENCIA!

1. No intente reparar o modificar si alguna pieza está rota o defectuosa. Por favor, póngase en contacto con la tienda de inmediato.
2. Este producto es para uso doméstico solamente y no destinado a establecimientos comerciales.

CONSEILS DE MONTAGE

1. Retirez le matériel de la boîte et de tri par taille.
2. Se il vous plaît vérifier que tout le matériel et les pièces sont présentes avant début de réunion .
3. Se il vous plaît suivre les instructions jointes dans la même séquence que numéroté pour assurer un montage rapide et facile .

ATTENTION!

1. À ne pas tenter de réparer ou de modifier une partie qui sont cassé ou défectueux. Se il vous plaît contactez immédiatement le magasin.
2. Ce produit est pour un usage domestique seulement et non destinés à des établissements commerciaux.



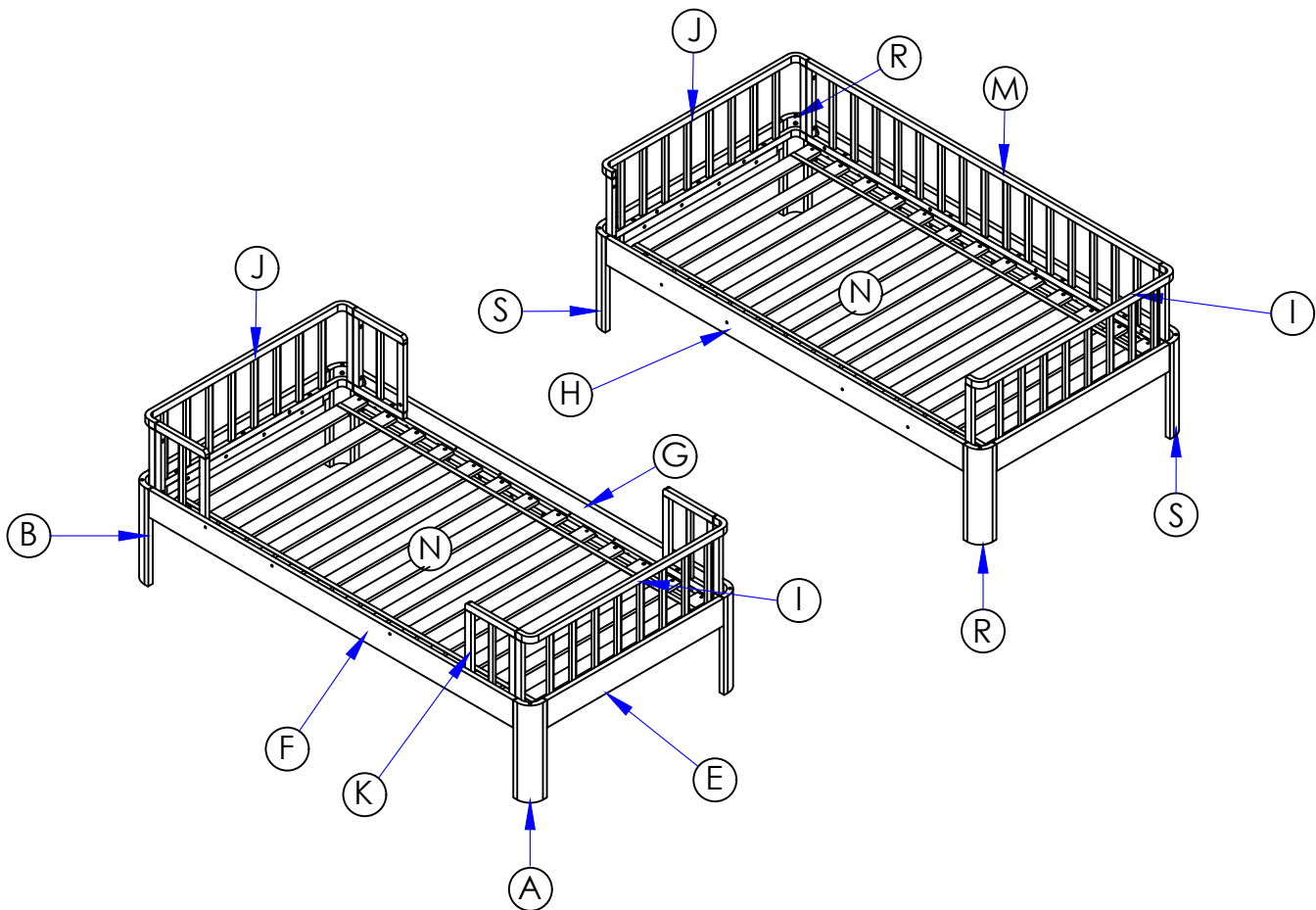











Identifying The Parts/Identification des pièces/ Identificación de piezas



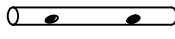

Part	Name Of Part List	Qty
A	Lower leg (Left rear & right front)	2pcs
B	Lower leg (Left front & right rear)	2pcs
C	Upper leg (Left rear & right front)	2pcs
D	Upper leg (Left front & right rear)	2pcs
E	Headboard/Footboard rail	4pcs
F	Lower front side rail	1pc
G	Upper & lower rear side rail	2pcs
H	Upper front side rail	1pc
I	Headboard/Footboard frame	2pcs
J	Headboard/Footboard frame with sticker	2pcs

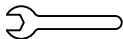
Part	Name Of Part List	Qty
K	Short guard frame	5pcs
L	Upper Front Guard Frame	1pc
M	Upper Rear Guard Frame	1pc
N	Slat	2sets
O	Right ladder rail	1pc
P	Left ladder rail	1pc
Q	Ladder stretcher	4pcs
R	Extra Lower Leg (Left Rear & Right Front)	2pcs
S	Extra Lower Leg (Right Rear & Left Front)	2pcs
T	Support rail	2pcs

HARDWARE PACK



NO.	DESCRIPTION		DIMENSION	QTY
1	Bolts		M6 x 60mm	8 pcs
2	Bolts		M6 x 40mm	24 pcs
3	Bolts		M6 x 16mm	16 pcs
4	Bolts		M6 x 40mm	27 pcs
5	Bolts		M6 x 28mm	16 pcs
6	Wood Screw		M4.0 x 28mm	56 pcs
7	JCN Nut		M6	4 pcs
8	Wood Dowel		Ø10 x 30mm	40 pcs
9	Barrel Nut		M6 x 13mm	8 pcs
10	Metal Pin With Hole		Ø10 x 100mm	4 pcs
11	Hanger Bolts		M8 x 60mm	24 pcs
12	H/M Washer		M8	24 pcs
13	H/M Nut		M8	24 pcs
14	Wrench		M8	1 pc
15	Allen Key		M4	1 pc

Step 1/ Étape 1/ Paso 1

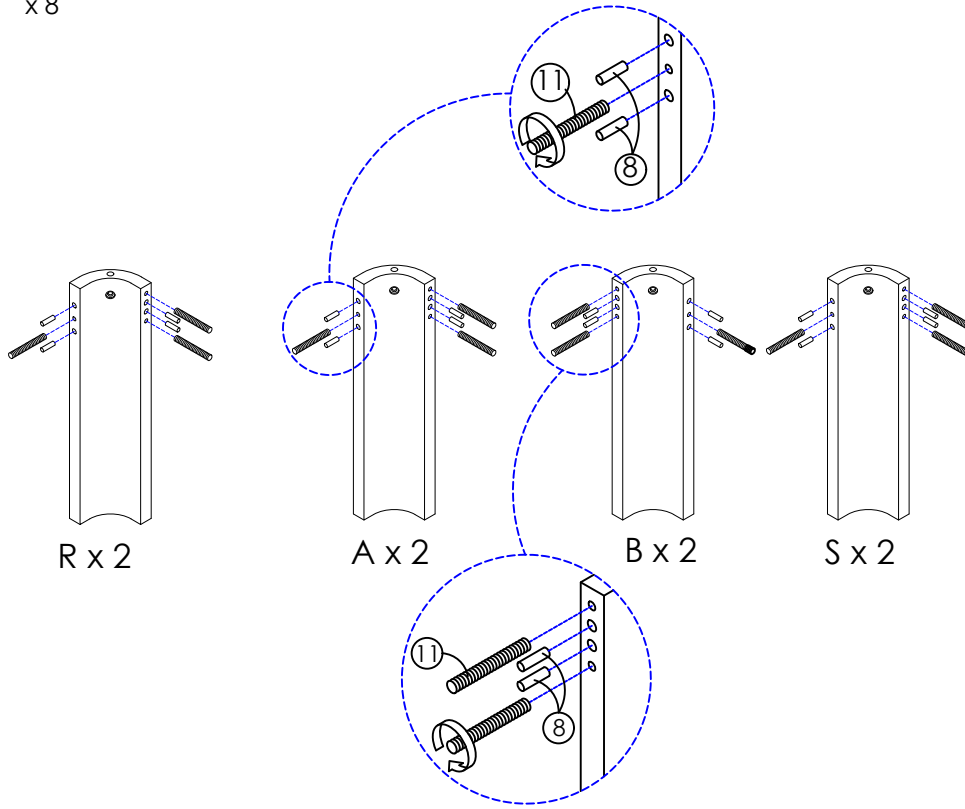
- ①  x 8
- ⑨  x 8



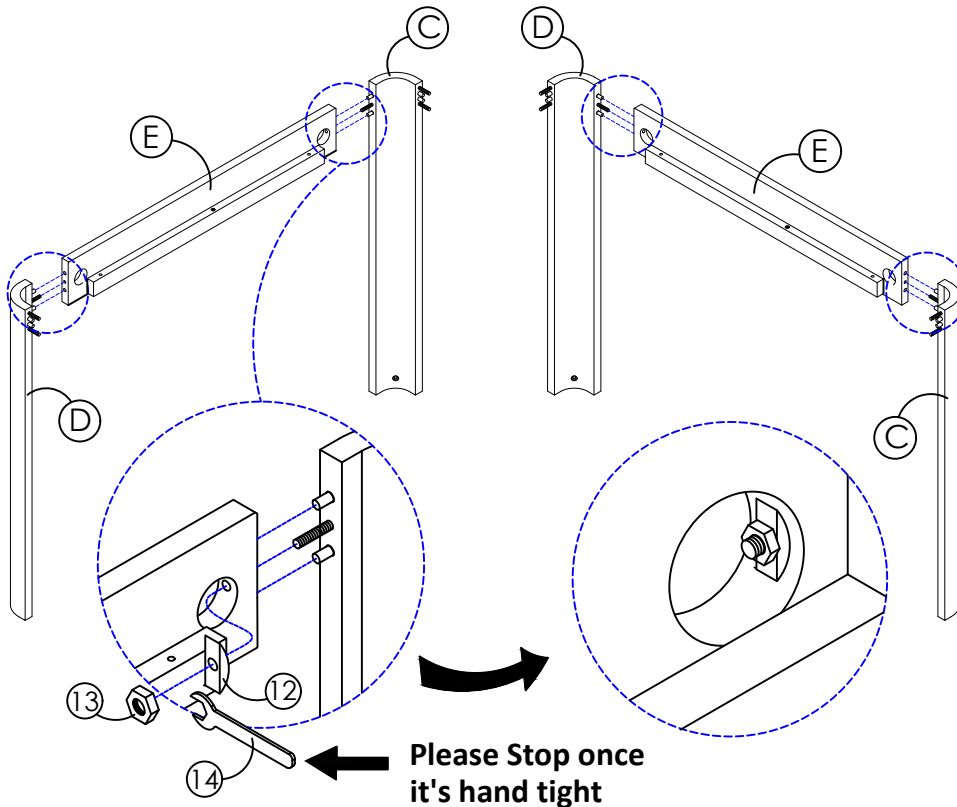

Step 2/ Étape 2/ Paso 2

- ⑫  x 4
- ⑬  x 4
- ⑭  x 1



Step 3/ Étape 3/ Paso 3

- ⑫  x 8
- ⑬  x 8
- ⑭  x 1

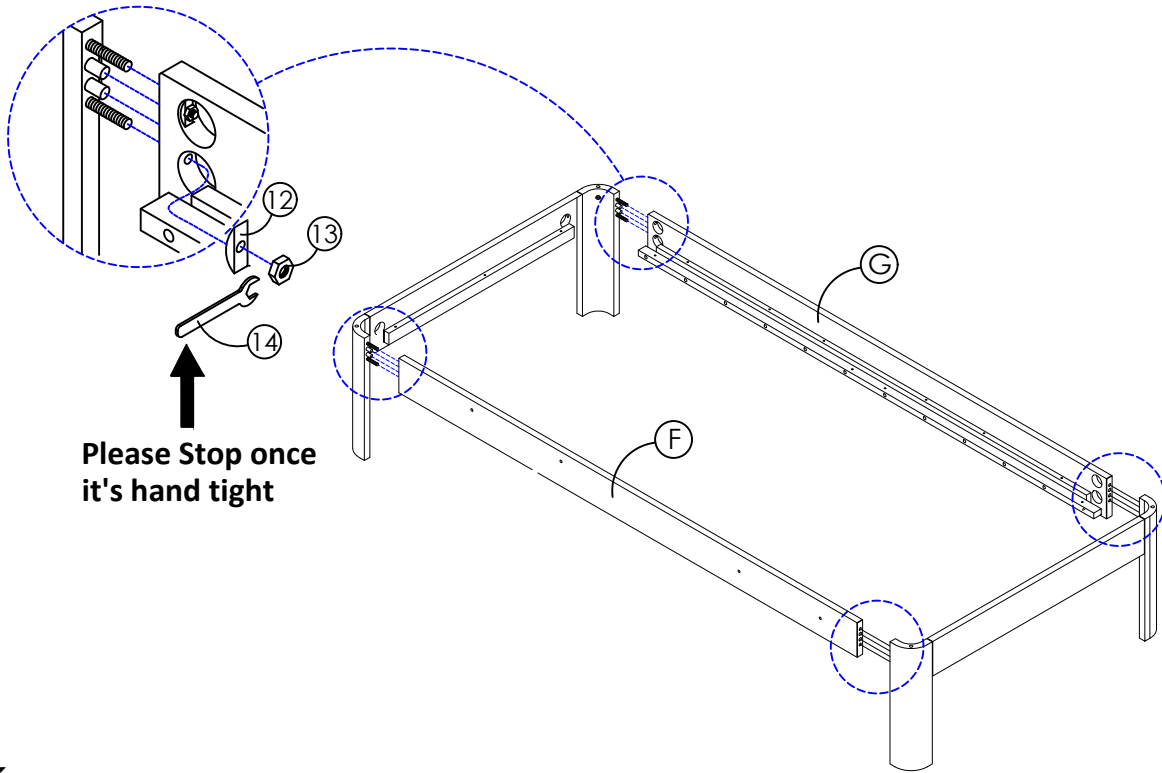

Please Stop once it's hand tight

Step 4/ Étape 4/ Paso 4

- ②  x 8
- ⑮  x 1

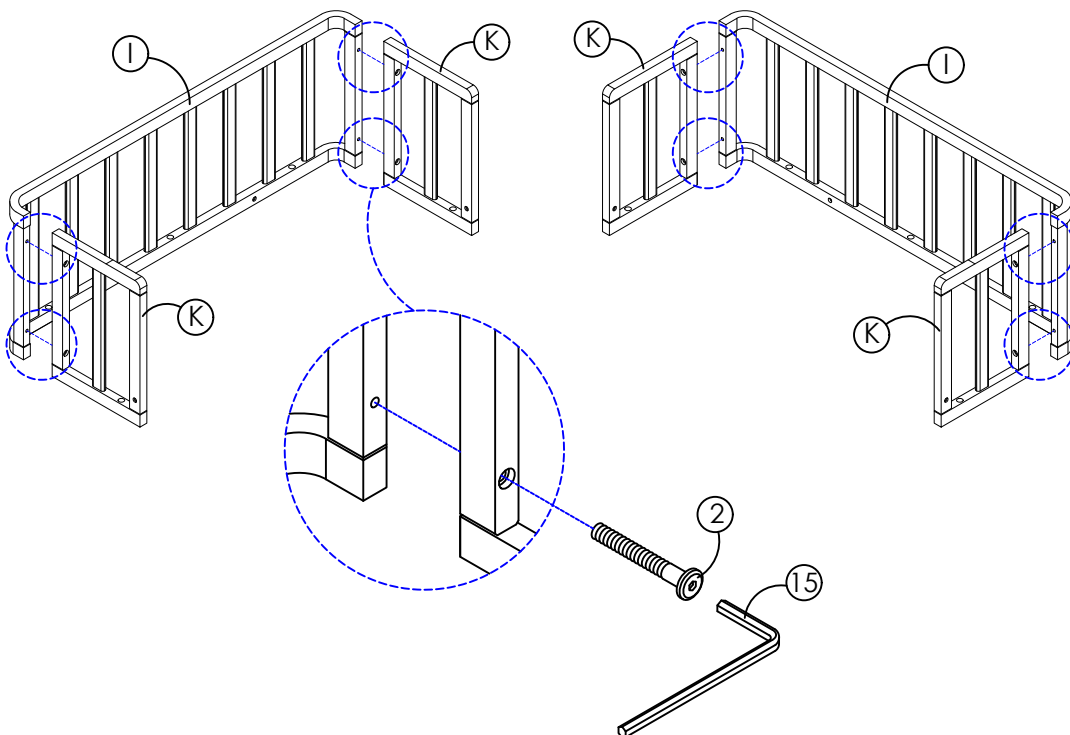

Step 5/ Étape 5/ Paso 5

④  x 10

⑮  x 1

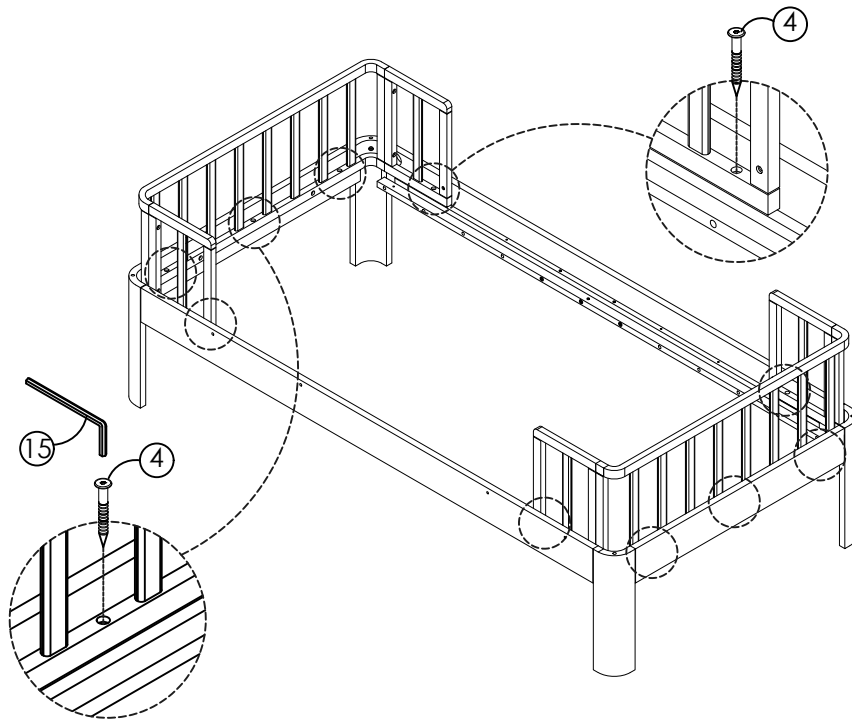

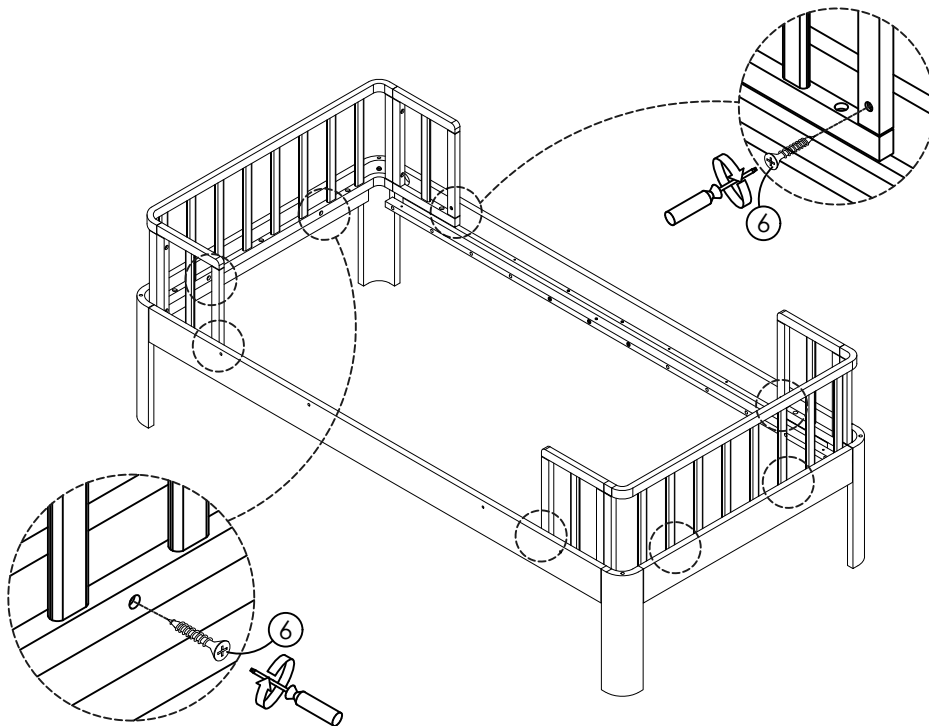

Step 6/ Étape 6/ Paso 6

⑥  x 8



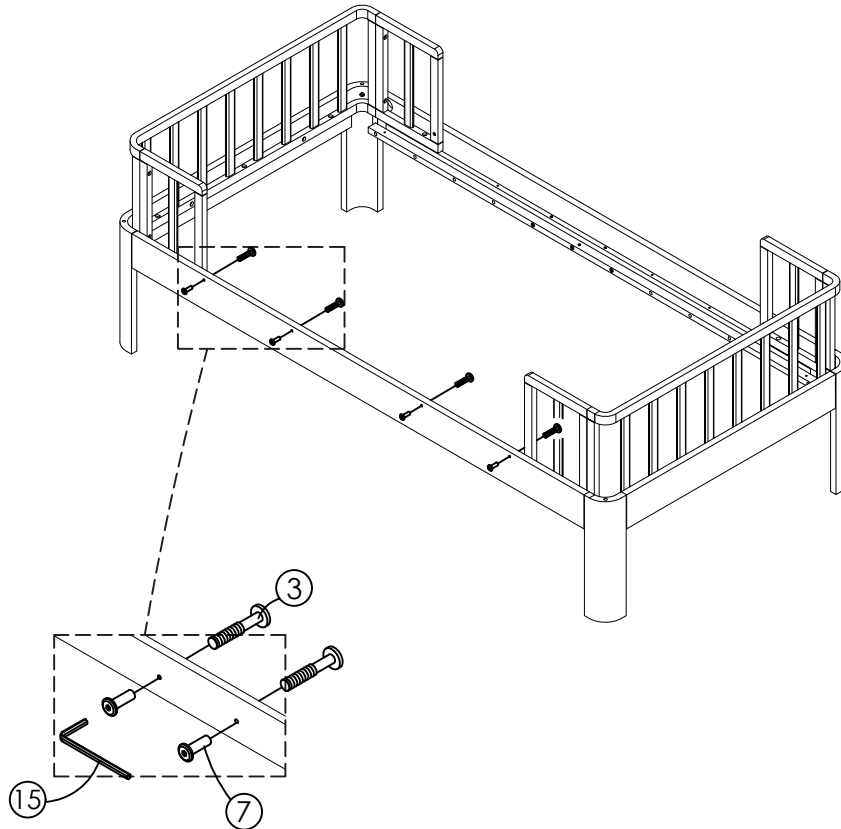

Step 7/ Étape 7/ Paso 7

- ③  x 4
- ⑦  x 4
- ⑮  x 1



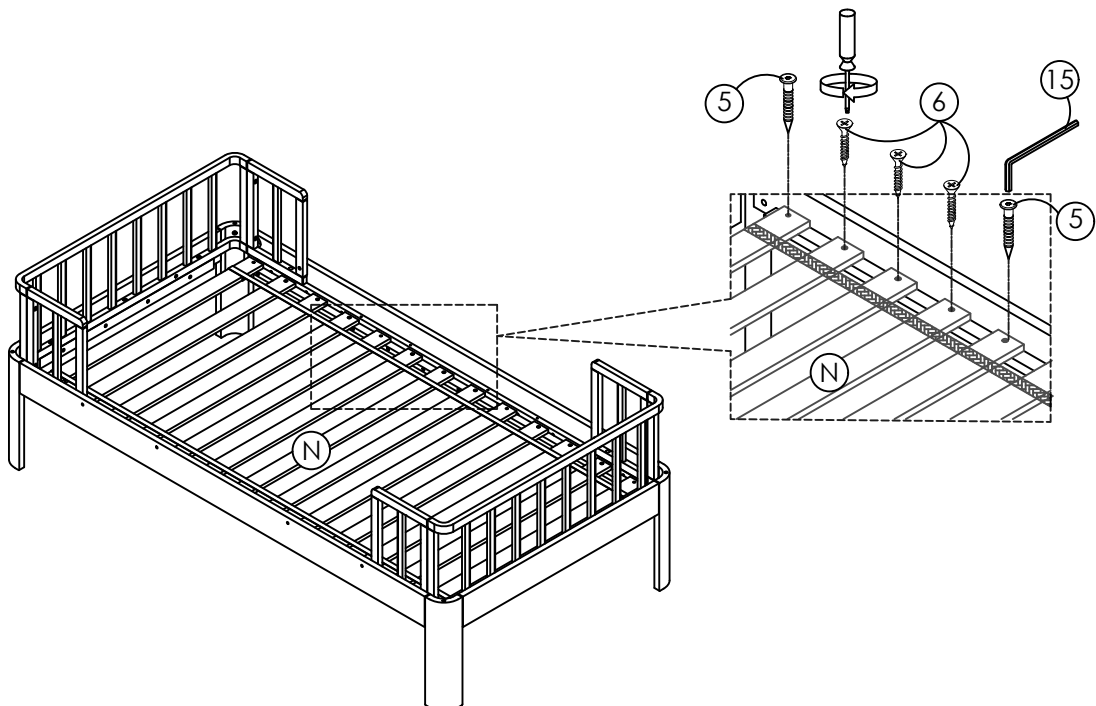

Step 8/ Étape 8/ Paso 8

- ⑥  x 18
- ⑤  x 8
- ⑮  x 1



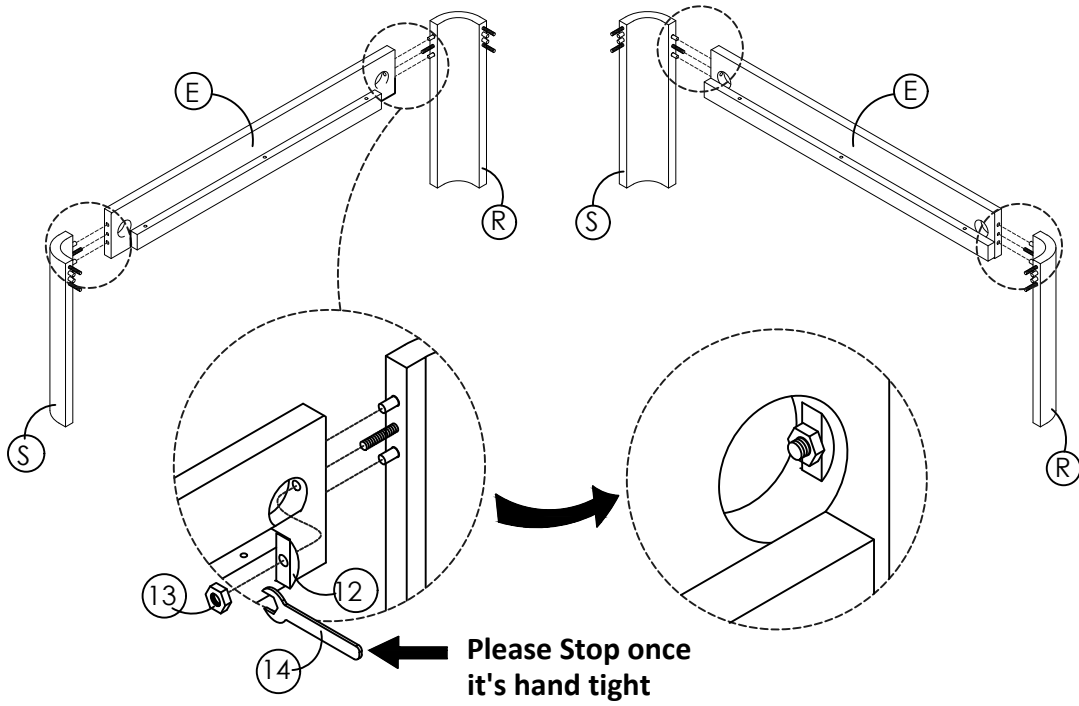

Step 9/ Étape 9/ Paso 9

- ⑫  x 4
- ⑬  x 4
- ⑭  x 1



Step 10/ Étape 10/ Paso 10

- ⑫  x 8
- ⑬  x 8
- ⑭  x 1

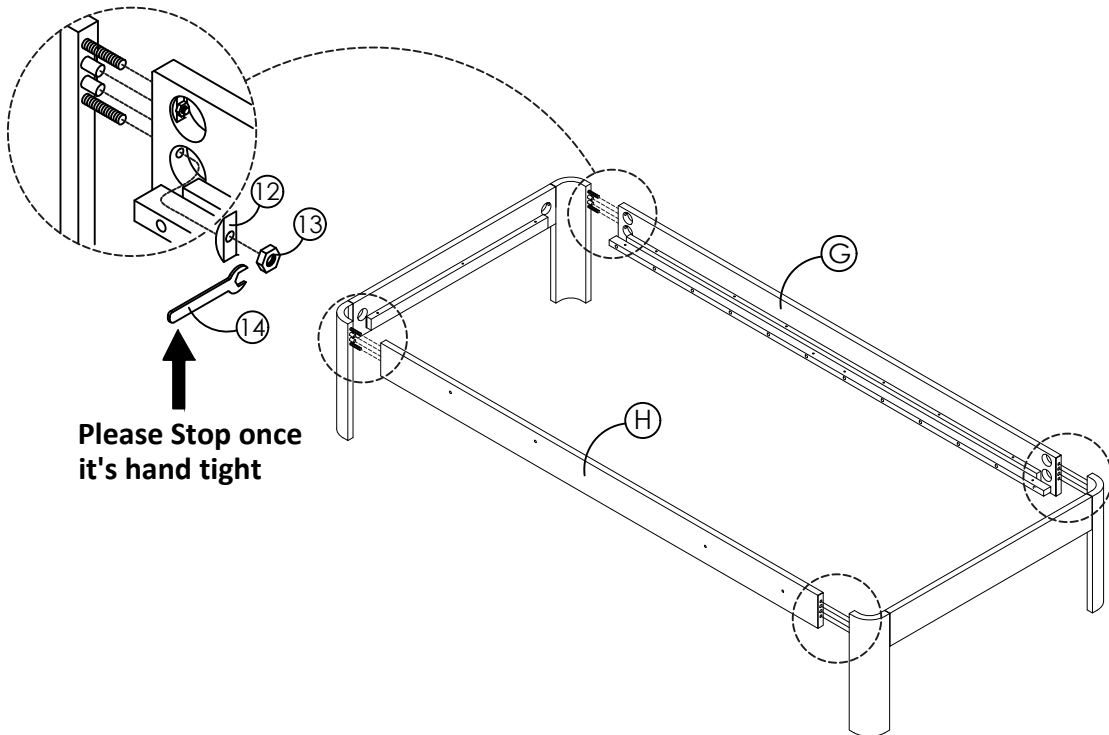

Step 11/ Étape 11/ Paso 11

④  x 3

⑮  x 1

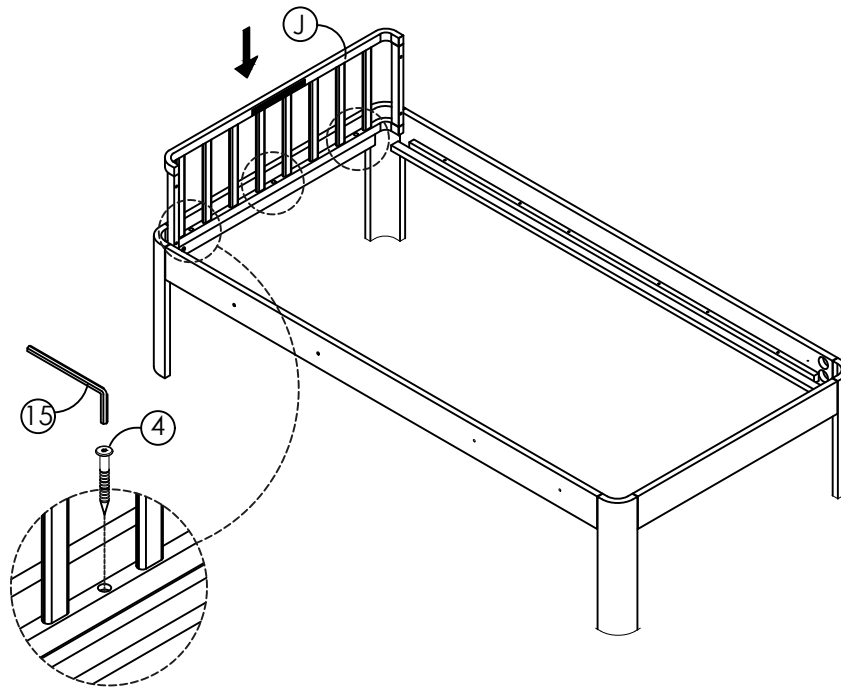

Step 12/ Étape 12/ Paso 12



②  x 2

④  x 6

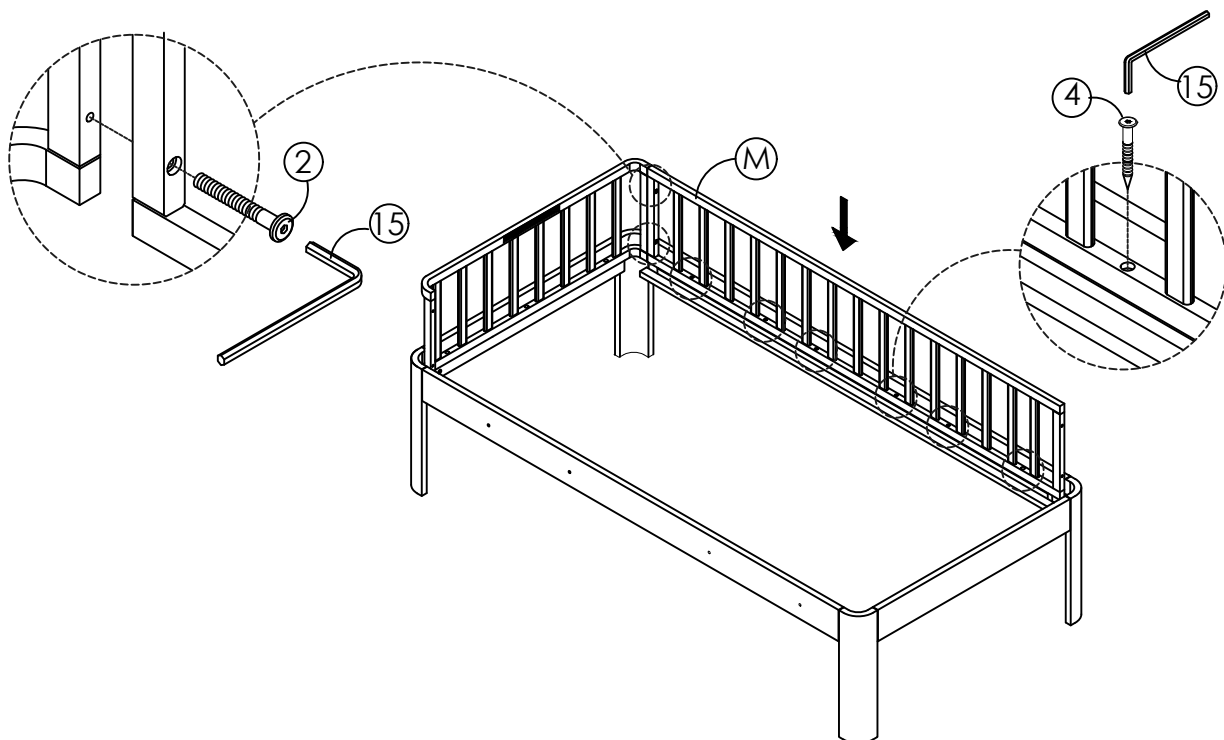
⑮  x 1



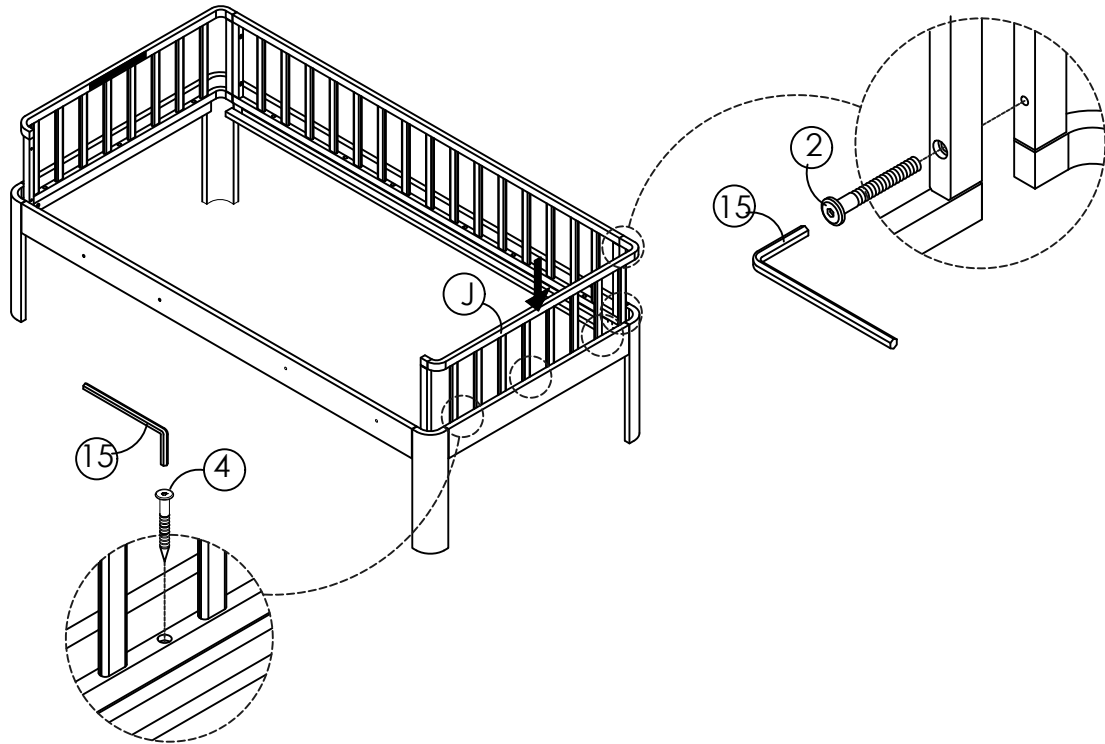

Step 13/ Étape 13/ Paso 13

- ②  x 2
- ④  x 3
- ⑮  x 1



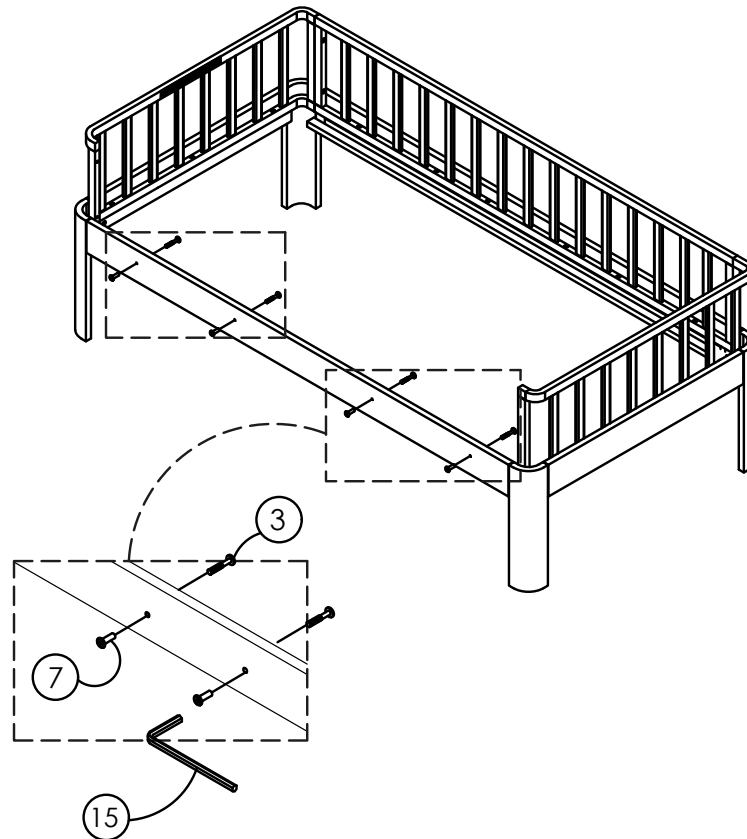

Step 14/ Étape 14/ Paso 14

- ③  x 4
- ⑦  x 4
- ⑮  x 1



Step 15/ Étape 15/ Paso 15

- ⑥  x 18
- ⑤  x 8
- ⑮  x 1

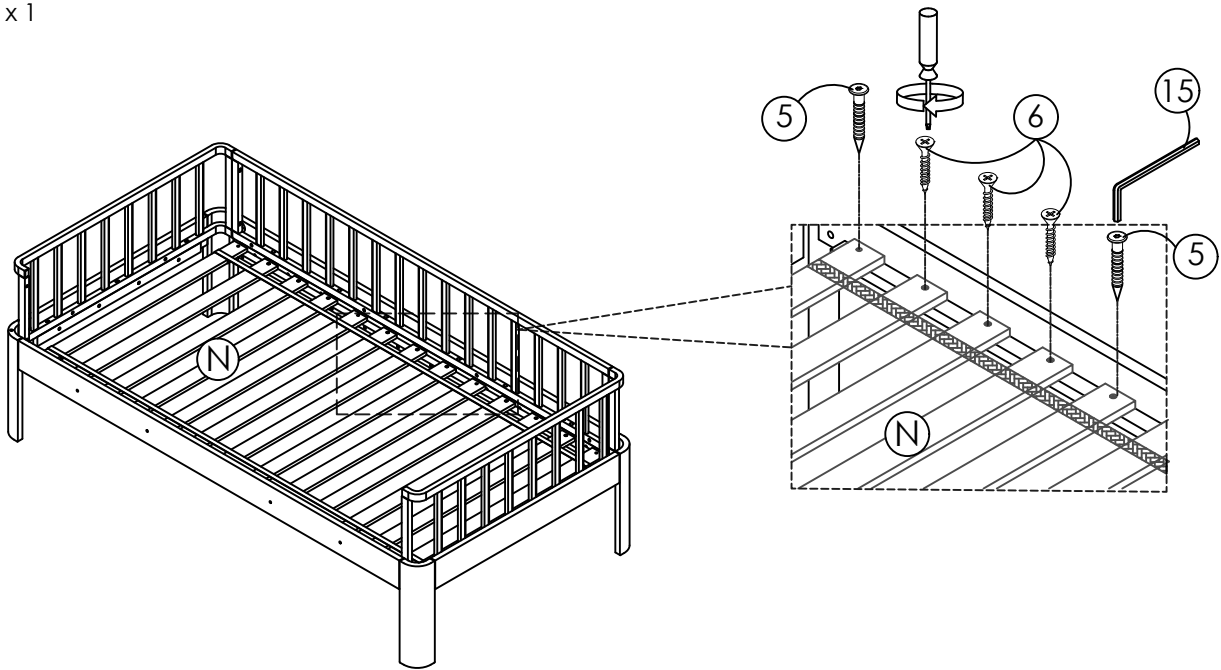

Step 16/ Étape 16/ Paso 16

COMPLETE ASSEMBLY FOR SINGLE BED & DAY BED
 ASSEMBLAGE COMPLET POUR LIT SIMPLE & LIT DE JOUR
 MONTAJE COMPLETO PARA CAMA INDIVIDUAL Y CAMA DE DÍA

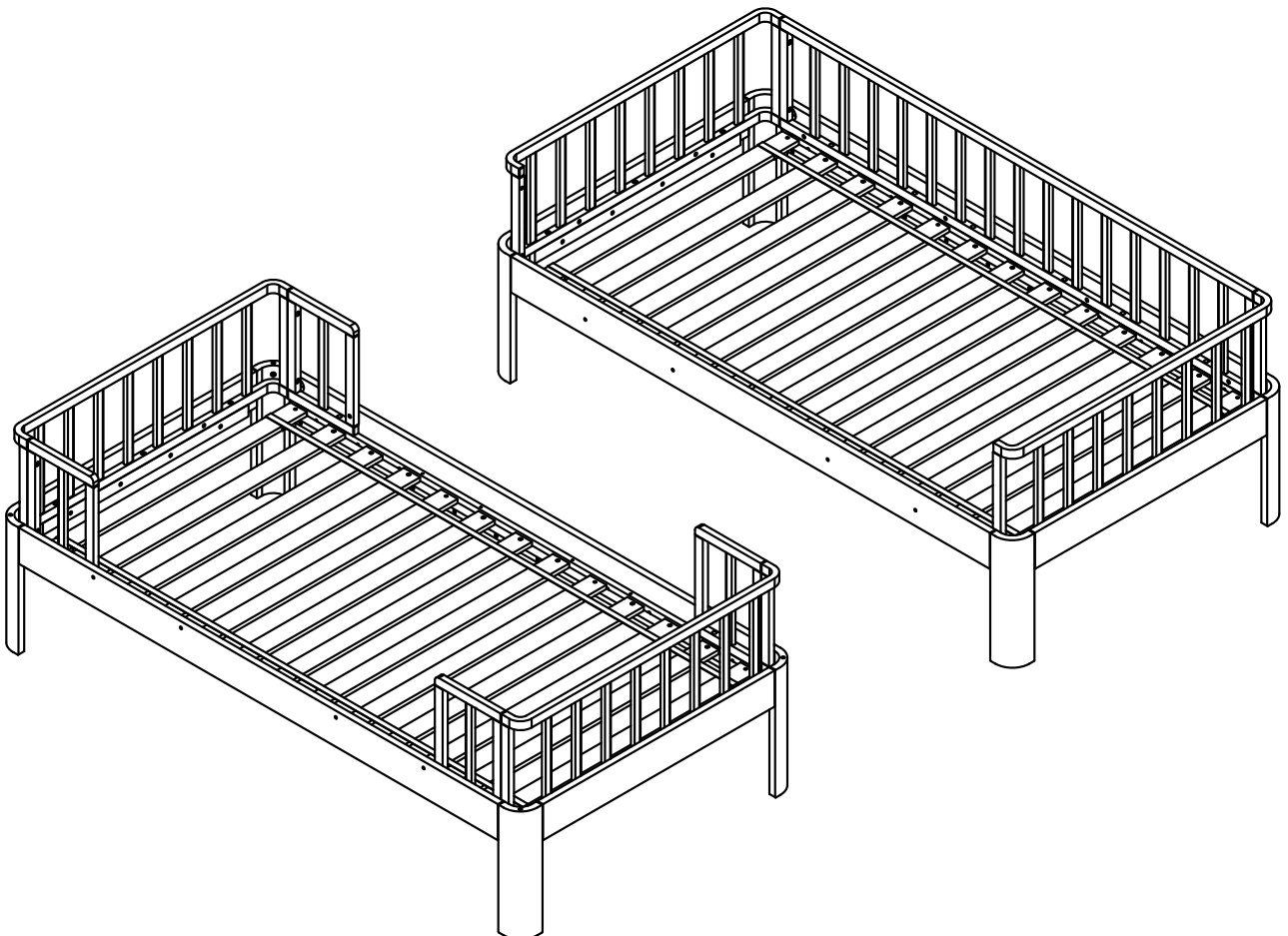

SINGLE BED & TODDLER BED / LIT SIMPLE ET LIT POUR TOUT-PETITS / CAMA INDIVIDUAL Y CAMA PARA NIÑOS PEQUEÑOS

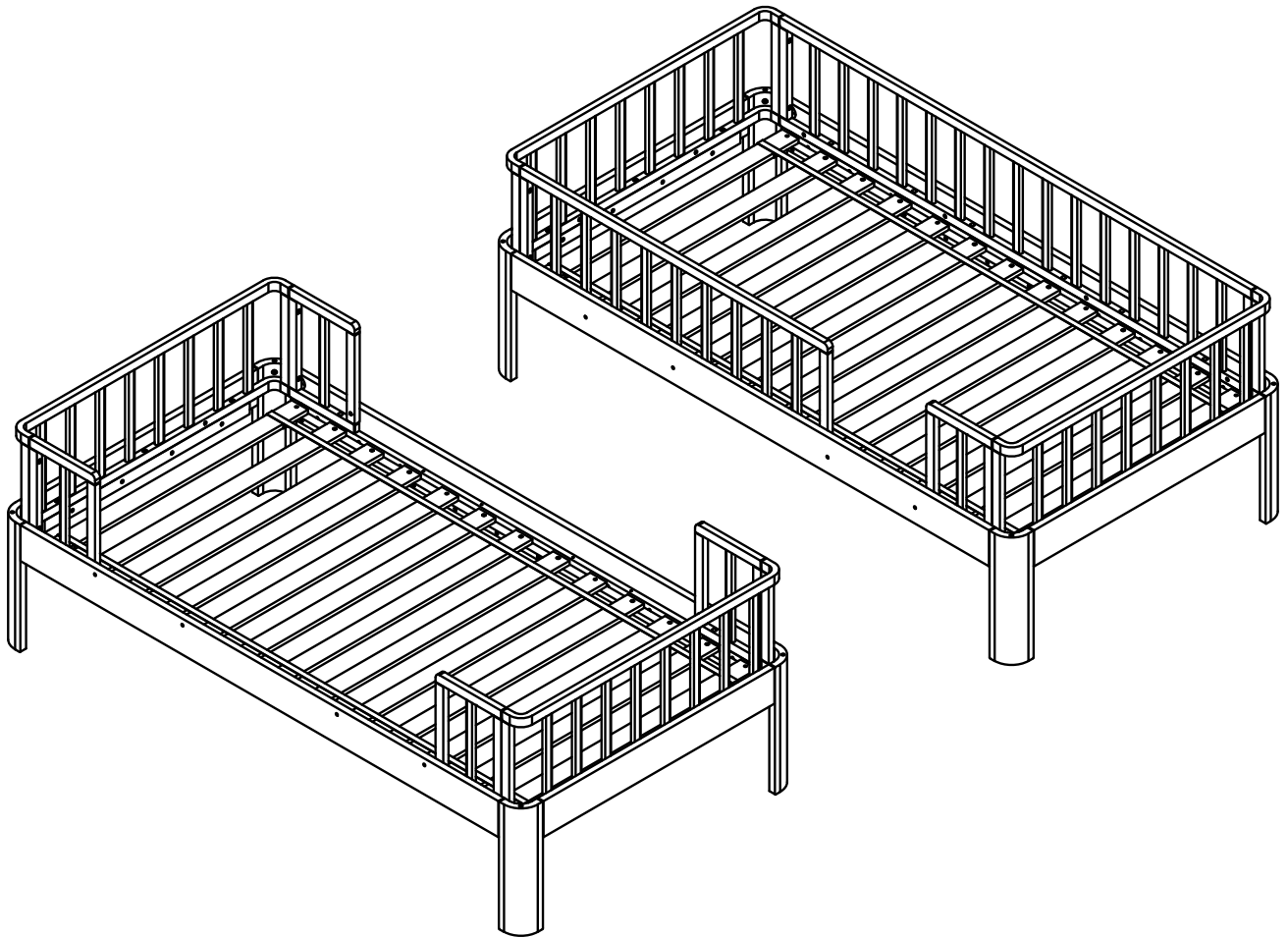

Identifying The Parts/Identification des pièces/ Identificación de piezas

ASSEMBLY TIPS

1. Remove hardware from box and sort by size.
2. Please check to see that all hardware and parts are present prior start of assembly.
3. Please follow attached instructions in the same sequence as numbered to assure fast and easy assembly.

WARNING!

1. Don't attempt to repair or modify part that are broken or defective. Please contact the store immediately.
2. This product is for home use only and not intended for commercial establishments.

RECOMENDACIONES DE ENSAMBLAJE

1. Retire el herraje de la caja y ordene por tamaño.
2. Por favor compruebe que todo el herraje y piezas estén listas antes del inicio del ensamble.
3. Por favor siga las instrucciones adjuntas en la misma secuencia numerada para asegurar un ensamblado rápido y fácil.

ADVERTENCIA!

1. No intente reparar o modificar si alguna pieza está rota o defectuosa. Por favor, póngase en contacto con la tienda de inmediato.
2. Este producto es para uso doméstico solamente y no destinado a establecimientos comerciales.

CONSEILS DE MONTAGE

1. Retirez le matériel de la boîte et de tri par taille.
2. Se il vous plaît vérifier que tout le matériel et les pièces sont présentes avant début de réunion .
3. Se il vous plaît suivre les instructions jointes dans la même séquence que numéroté pour assurer un montage rapide et facile .

ATTENTION!

1. À ne pas tenter de réparer ou de modifier une partie qui sont cassé ou défectueux. Se il vous plaît contactez immédiatement le magasin.
2. Ce produit est pour un usage domestique seulement et non destinés à des établissements commerciaux.



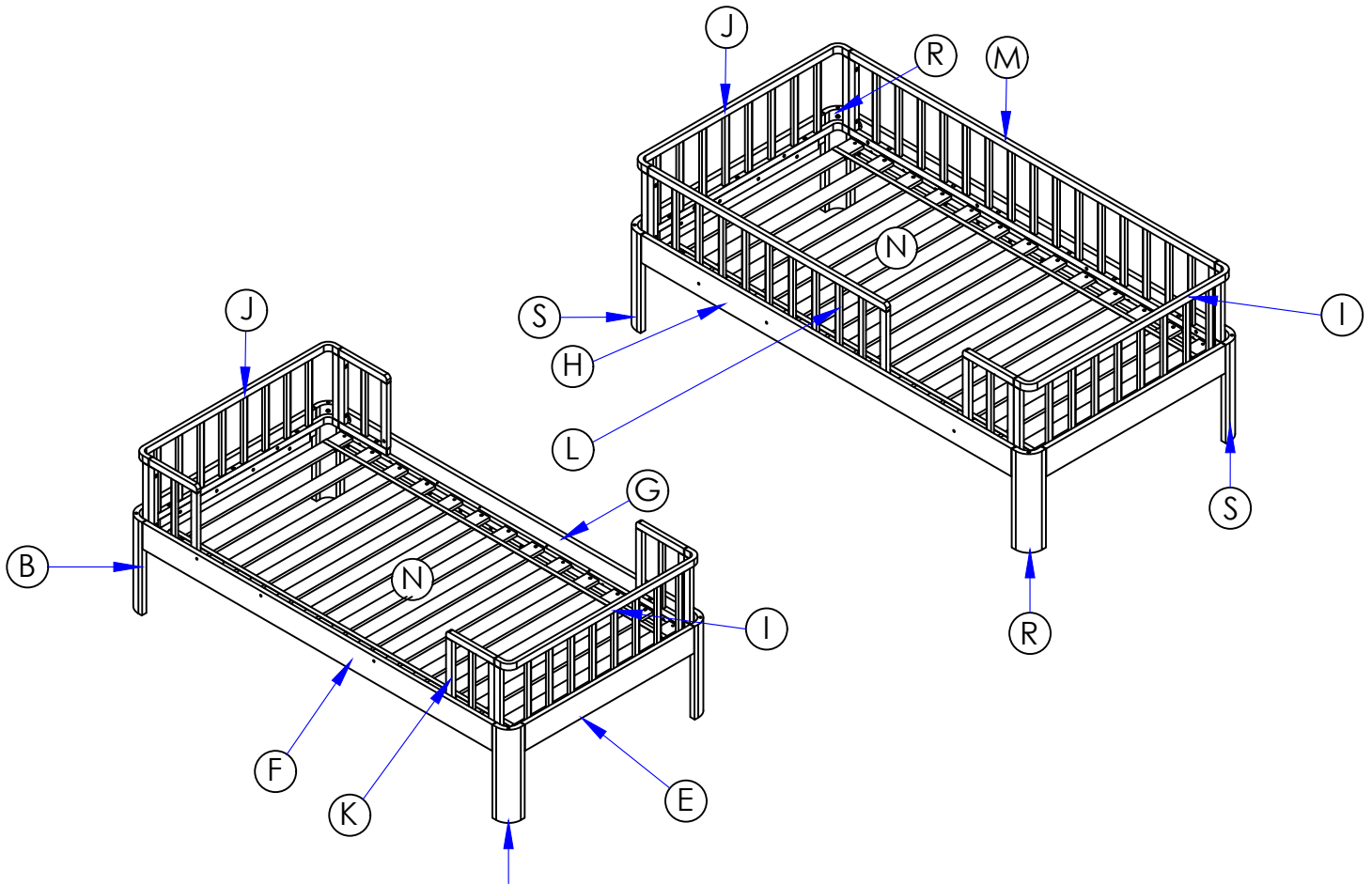











Identifying The Parts/Identification des pièces/ Identificación de piezas



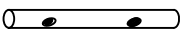

Part	Name Of Part List	Qty
A	Lower leg (Left rear & right front)	2pcs
B	Lower leg (Left front & right rear)	2pcs
C	Upper leg (Left rear & right front)	2pcs
D	Upper leg (Left front & right rear)	2pcs
E	Headboard/Footboard rail	4pcs
F	Lower front side rail	1pc
G	Upper & lower rear side rail	2pcs
H	Upper front side rail	1pc
I	Headboard/Footboard frame	2pcs
J	Headboard/Footboard frame with sticker	2pcs

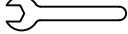
Part	Name Of Part List	Qty
K	Short guard frame	5pcs
L	Upper Front Guard Frame	1pc
M	Upper Rear Guard Frame	1pc
N	Slat	2sets
O	Right ladder rail	1pc
P	Left ladder rail	1pc
Q	Ladder stretcher	4pcs
R	Extra Lower Leg (Left Rear & Right Front)	2pcs
S	Extra Lower Leg (Right Rear & Left Front)	2pcs
T	Support rail	2pcs

HARDWARE PACK



NO.	DESCRIPTION		DIMENSION	QTY
1	Bolts		M6 x 60mm	8 pcs
2	Bolts		M6 x 40mm	24 pcs
3	Bolts		M6 x 16mm	16 pcs
4	Bolts		M6 x 40mm	27 pcs
5	Bolts		M6 x 28mm	16 pcs
6	Wood Screw		M4.0 x 28mm	56 pcs
7	JCN Nut		M6	8 pcs
8	Wood Dowel		Ø10 x 30mm	40 pcs
9	Barrel Nut		M6 x 13mm	8 pcs
10	Metal Pin With Hole		Ø10 x 100mm	4 pcs
11	Hanger Bolts		M8 x 60mm	24 pcs
12	H/M Washer		M8	24 pcs
13	H/M Nut		M8	24 pcs
14	Wrench		M8	1 pc
15	Allen Key		M4	1 pc

Step 1/ Étape 1/ Paso 1

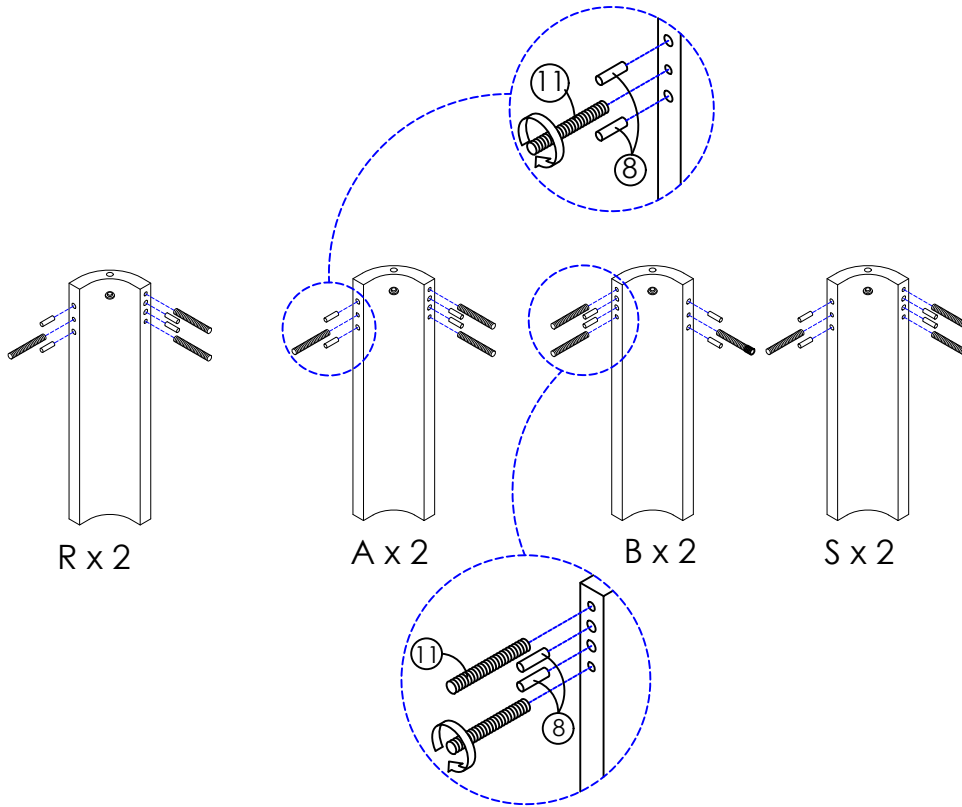
- ①  x 8
- ⑨  x 8



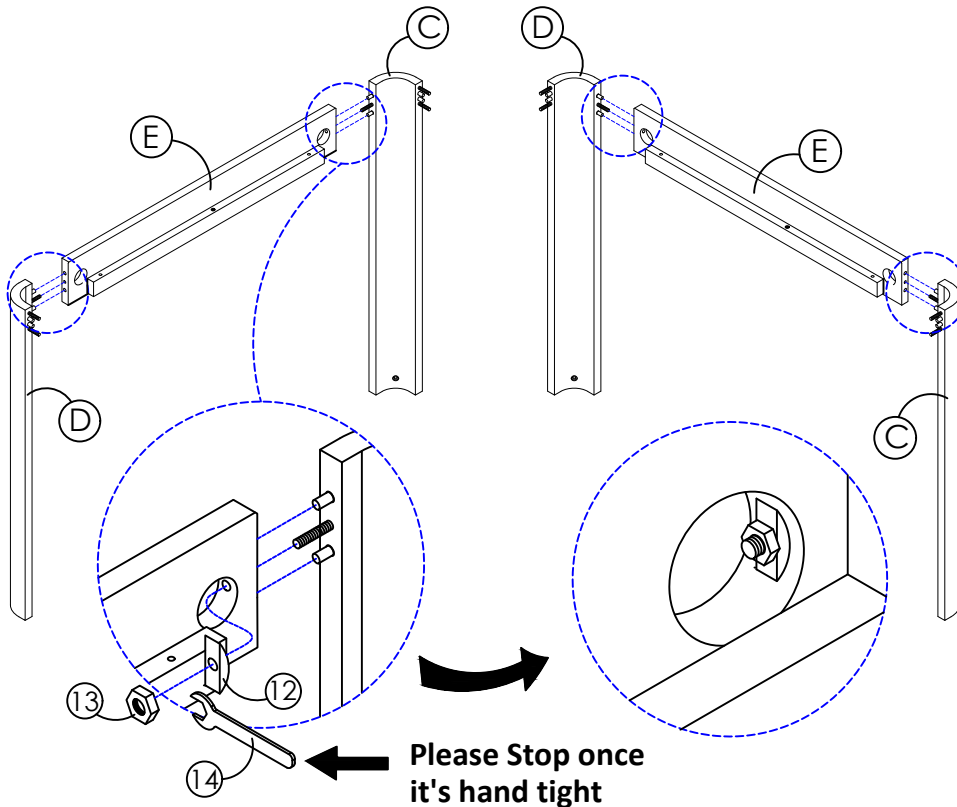

Step 2/ Étape 2/ Paso 2

- ⑫  x 4
- ⑬  x 4
- ⑭  x 1



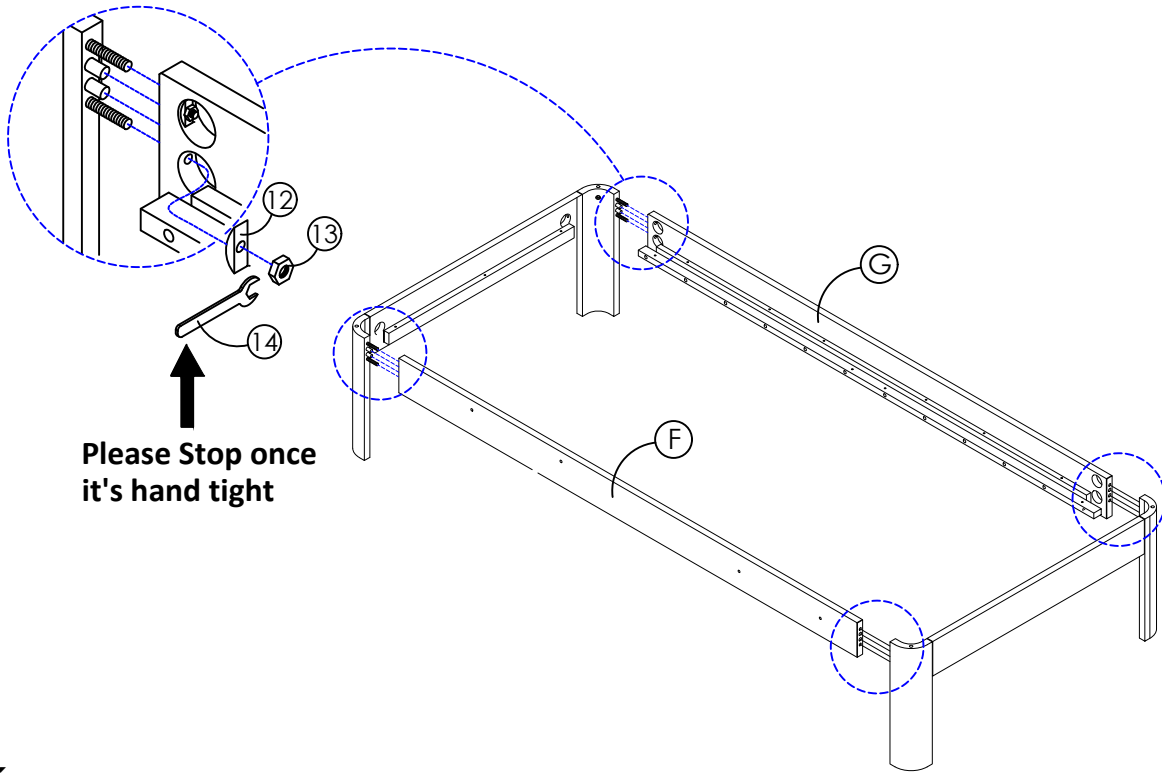

Step 3/ Étape 3/ Paso 3

- ⑫  x 8
- ⑬  x 8
- ⑭  x 1



Please Stop once
it's hand tight

Step 4/ Étape 4/ Paso 4

- ②  x 8
- ⑮  x 1

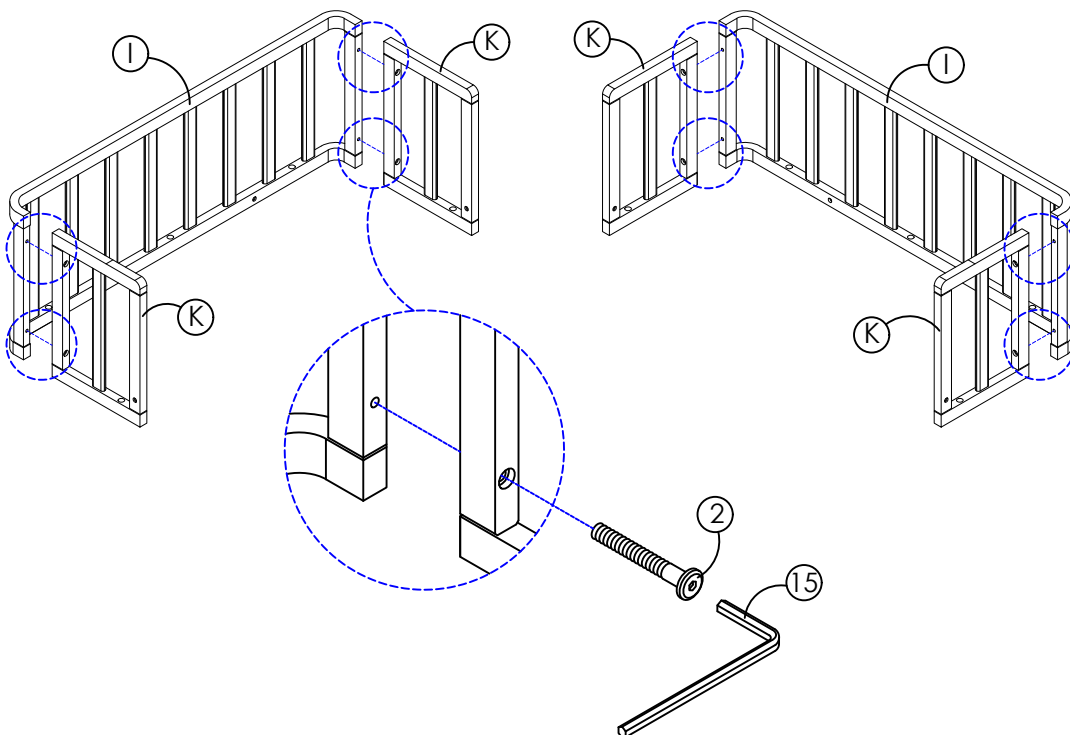

Step 5/ Étape 5/ Paso 5

④  x 10

⑮  x 1

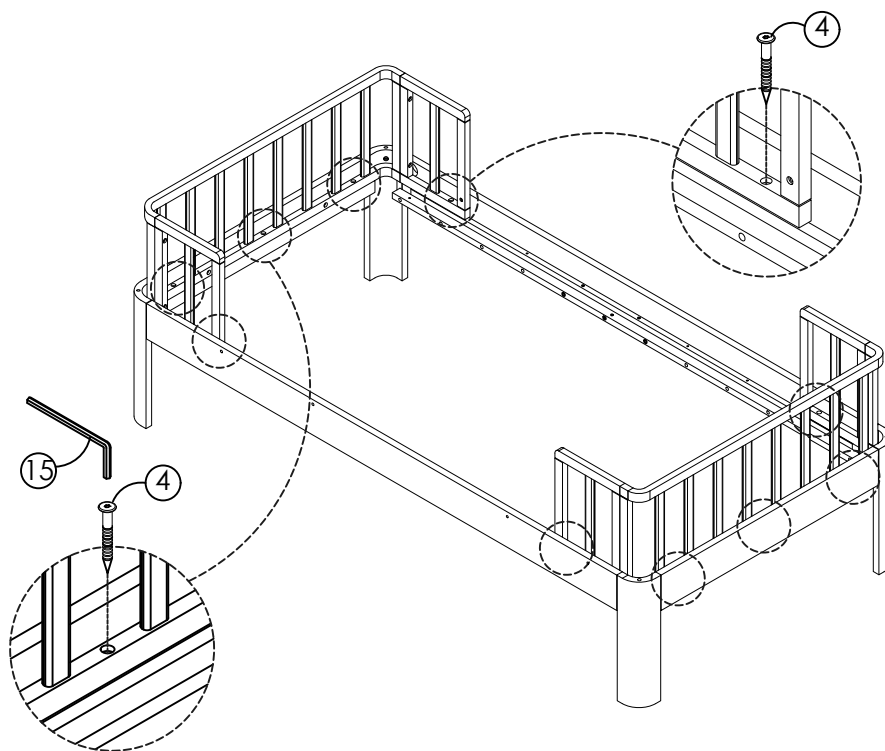

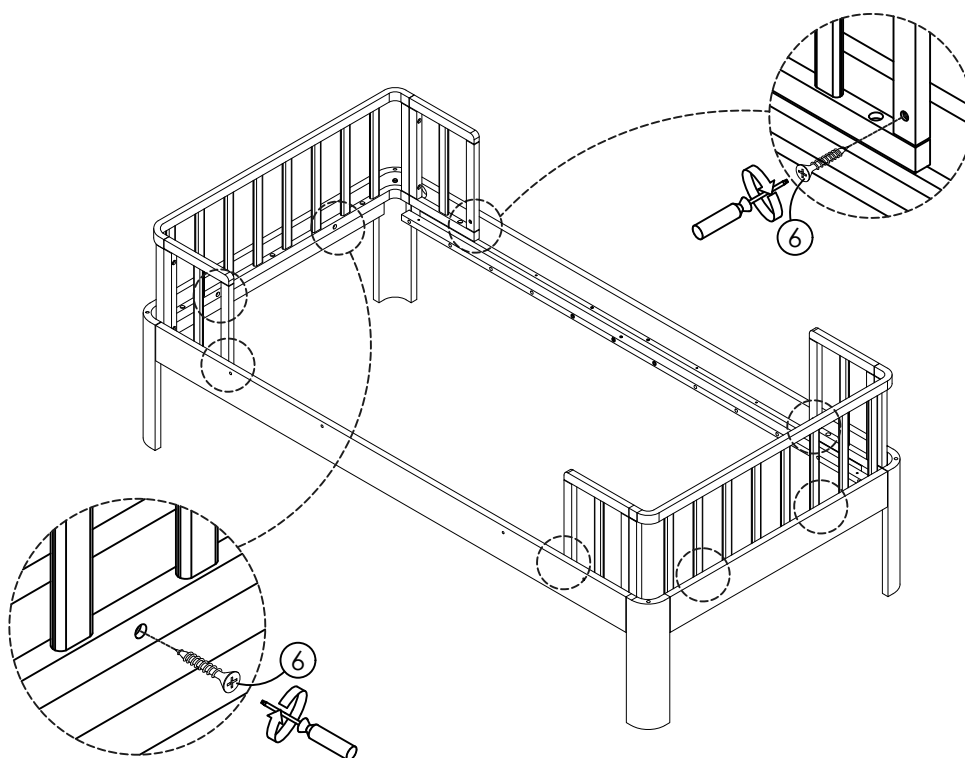

Step 6/ Étape 6/ Paso 6

⑥  x 8



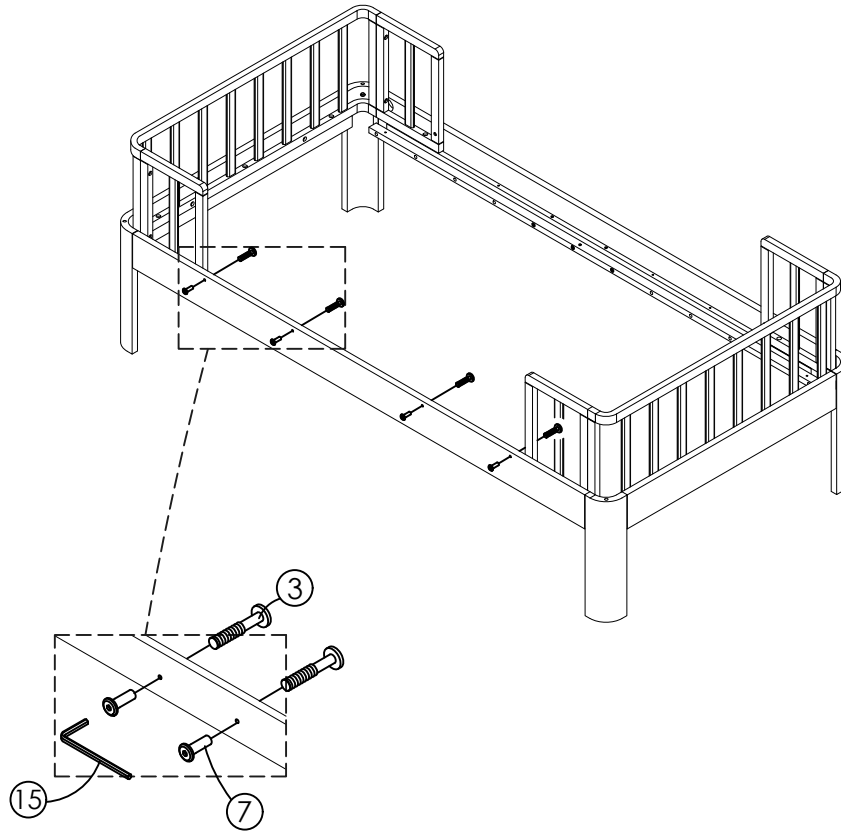

Step 7/ Étape 7/ Paso 7

- ③  x 4
- ⑦  x 4
- ⑮  x 1



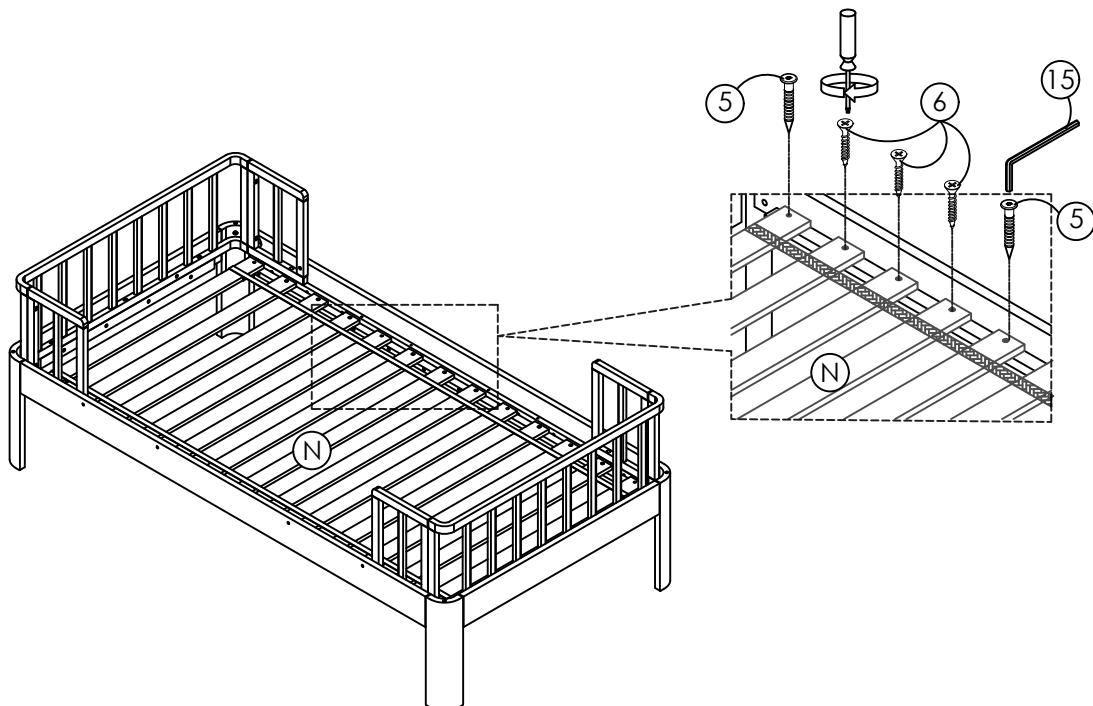

Step 8/ Étape 8/ Paso 8

- ⑥  x 18
- ⑤  x 8
- ⑮  x 1



Step 9/ Étape 9/ Paso 9

- ⑫  x 4
- ⑬  x 4
- ⑭  x 1

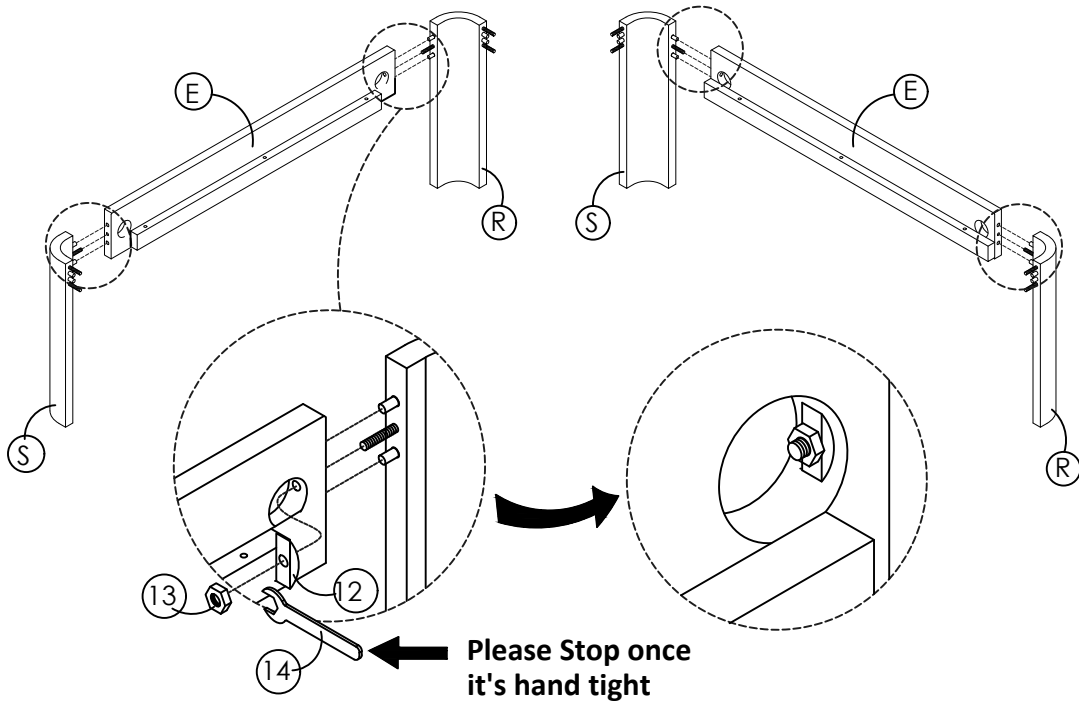

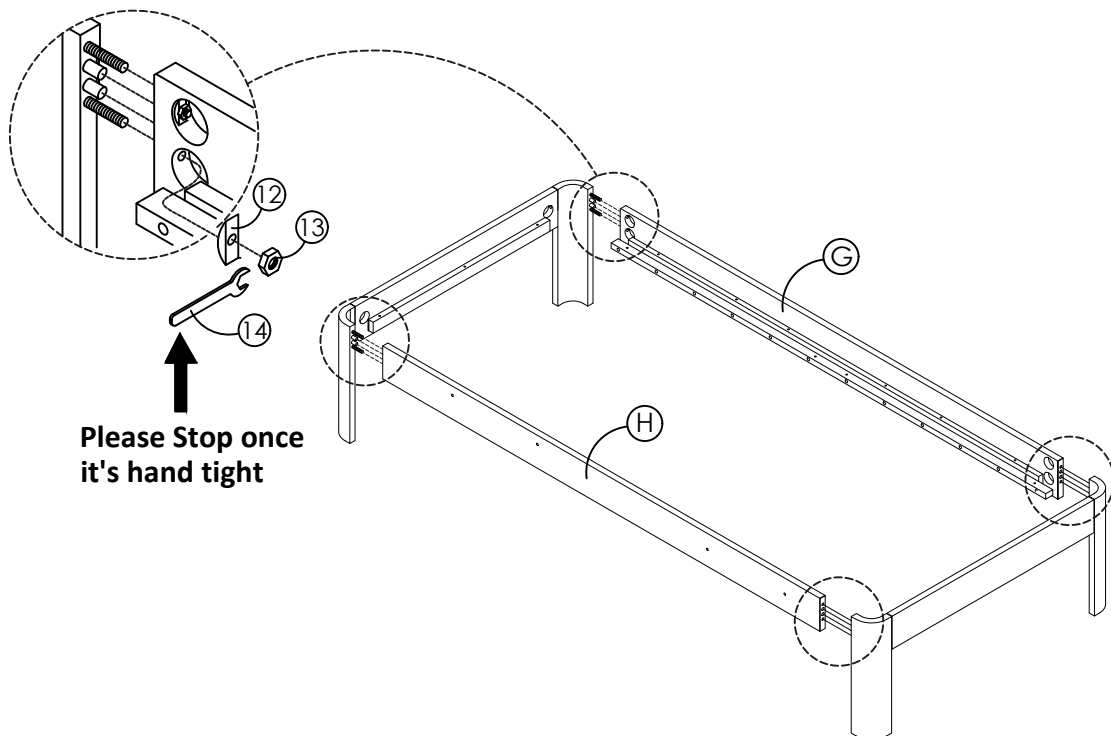

Step 10/ Étape 10/ Paso 10

- ⑫  x 8
- ⑬  x 8
- ⑭  x 1



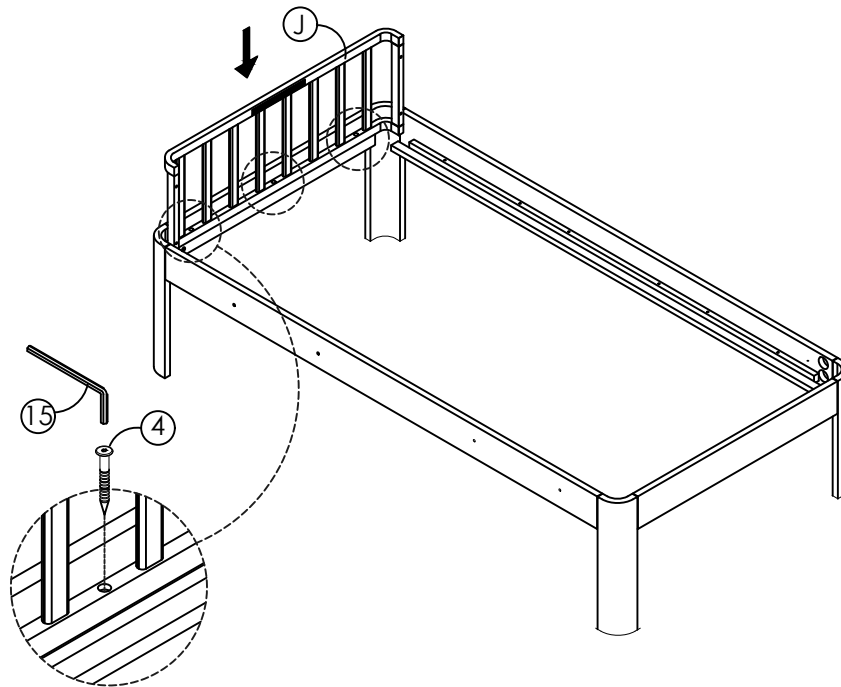

Step 11/ Étape 11/ Paso 11

- ④  x 3
- ⑮  x 1



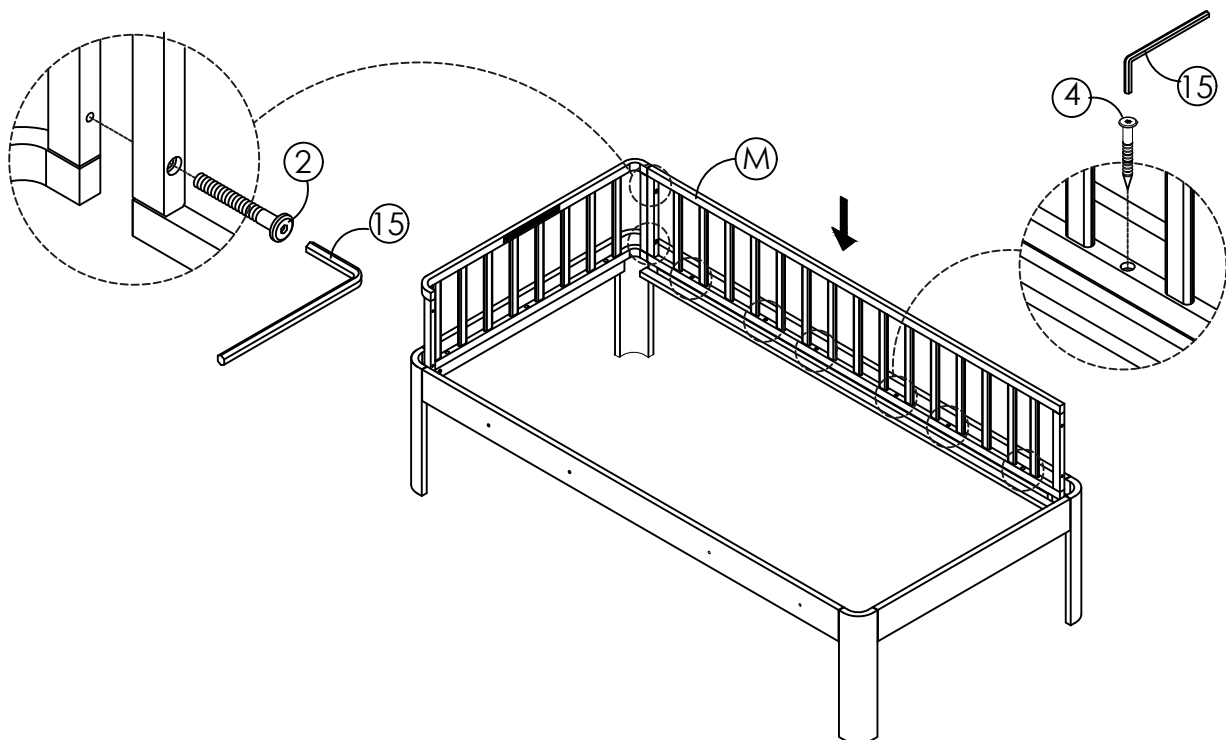

Step 12/ Étape 12/ Paso 12

- ②  x 2
- ④  x 6
- ⑮  x 1



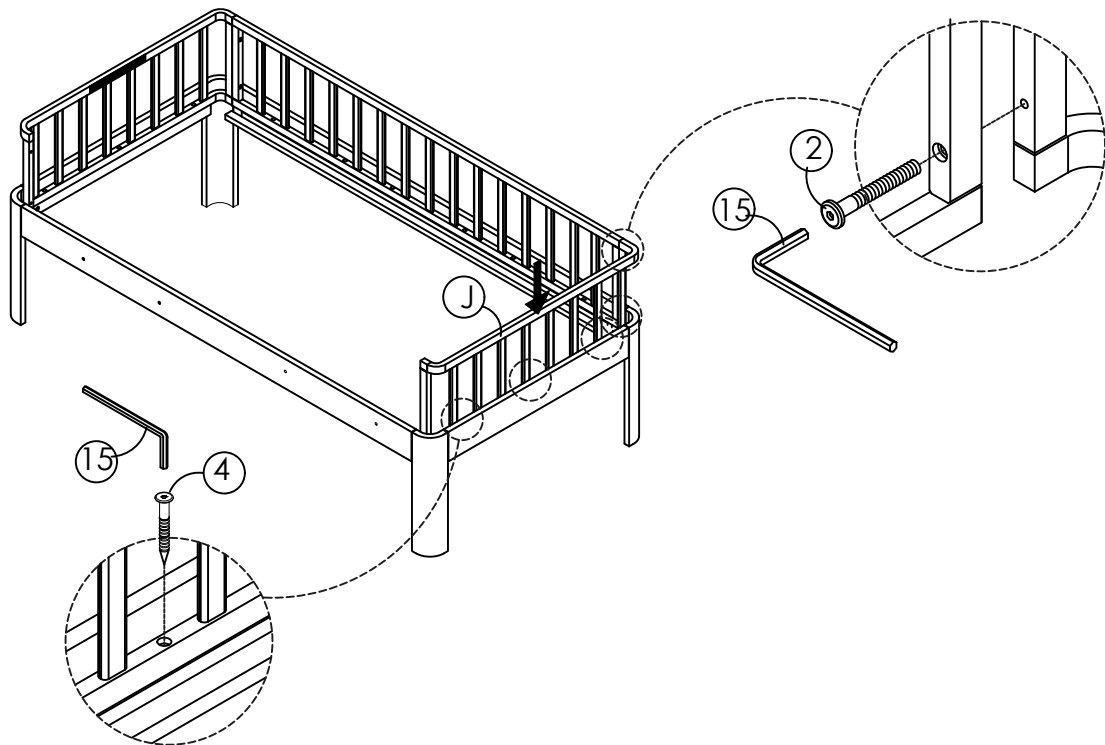

Step 13/ Étape 13/ Paso 13

- ②  x 2
- ④  x 3
- ⑮  x 1



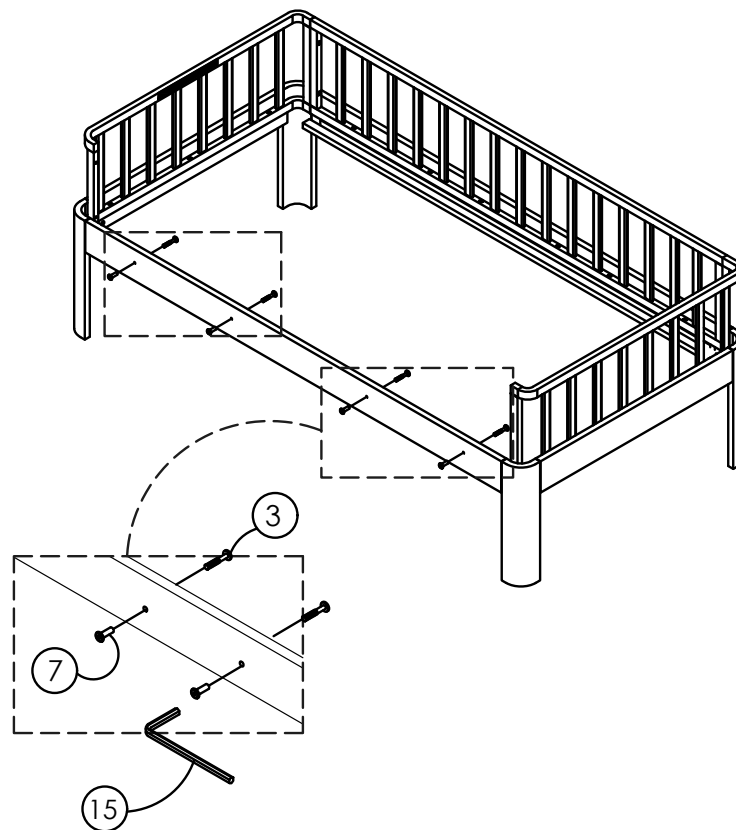

Step 14/ Étape 14/ Paso 14

- ③  x 4
- ⑦  x 4
- ⑮  x 1



Step 15/ Étape 15/ Paso 15

- ②  x 2
- ④  x 6
- ⑮  x 1

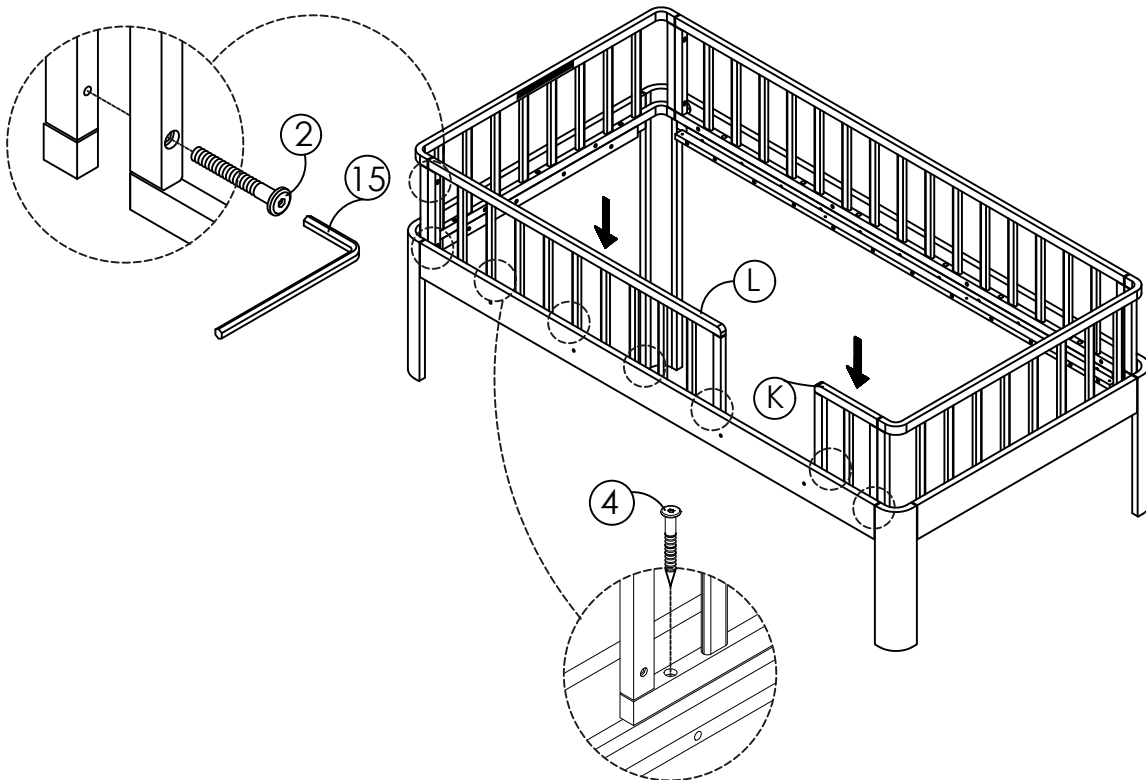

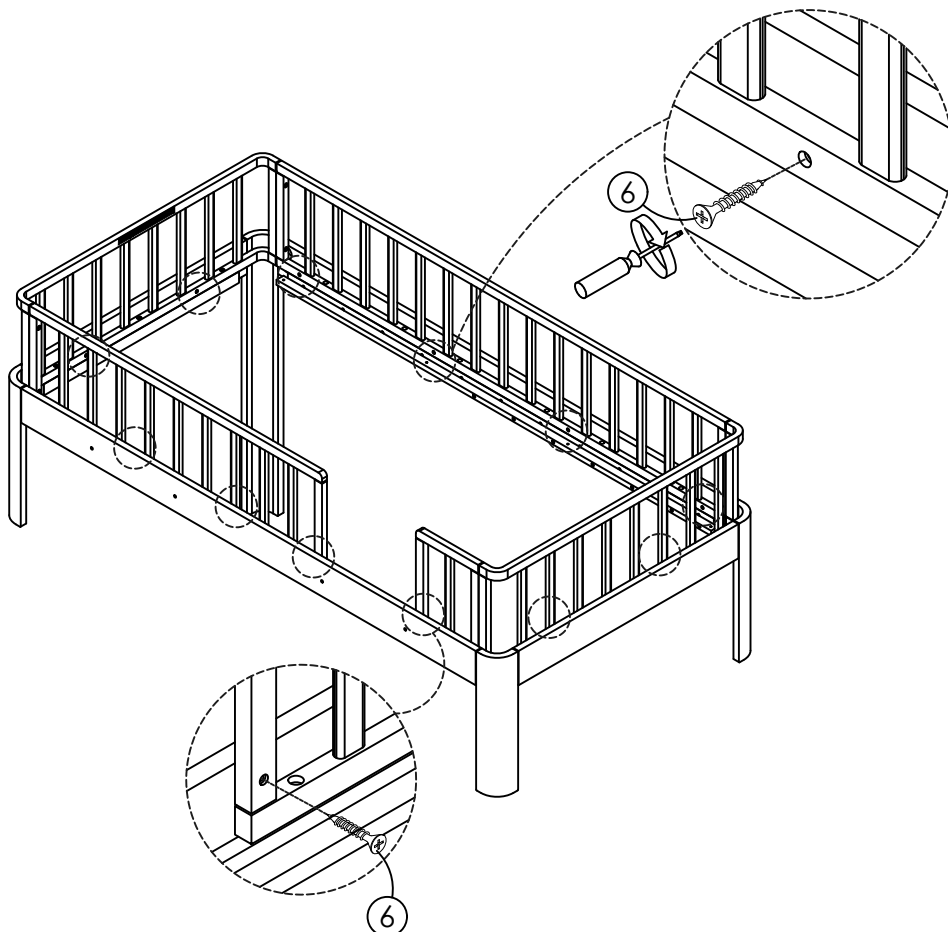

Step 16/ Étape 16/ Paso 16

- ⑥  x 12



Step 17/ Étape 17/ Paso 17

- ⑥  x 18
- ⑤  x 8
- ⑮  x 1

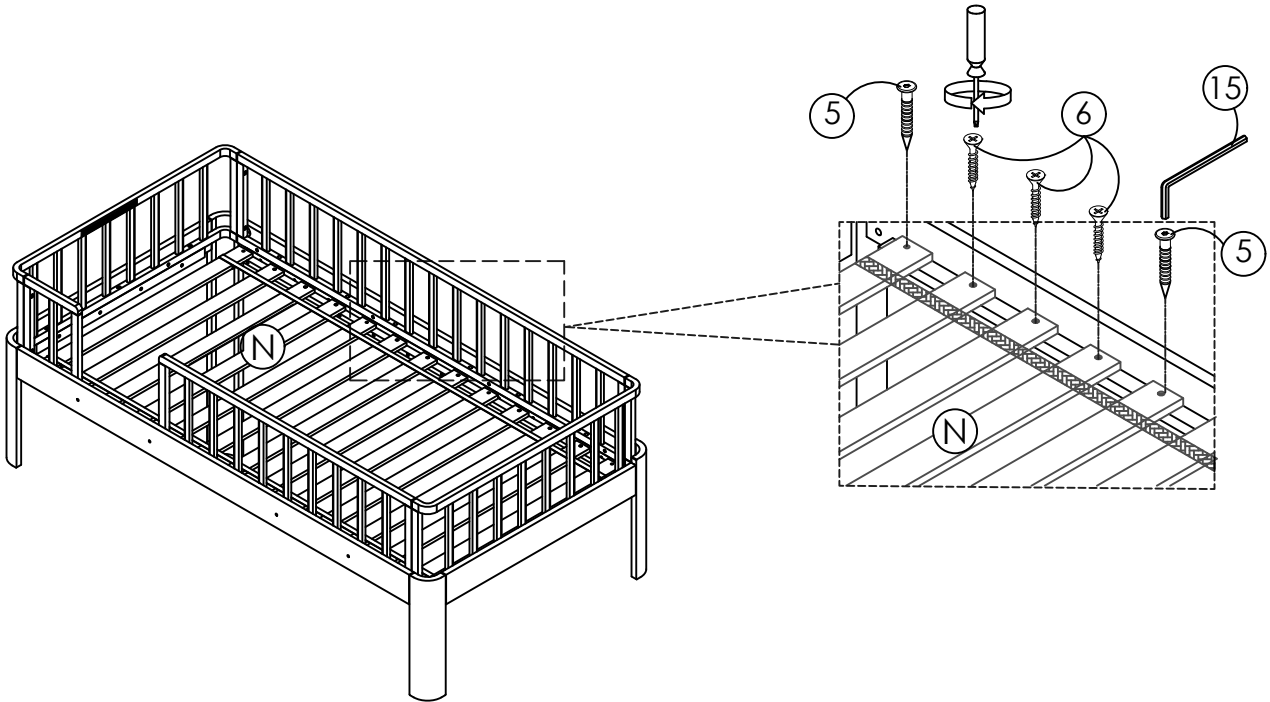

Step 16/ Étape 16/ Paso 16

COMPLETE ASSEMBLY FOR SINGLE BED & TODDLER BED
 ASSEMBLAGE COMPLET POUR LIT SIMPLE ET LIT POUR TOUT-PETITS
 MONTAJE COMPLETO PARA CAMA INDIVIDUAL Y CAMA PARA NIÑOS PEQUEÑOS

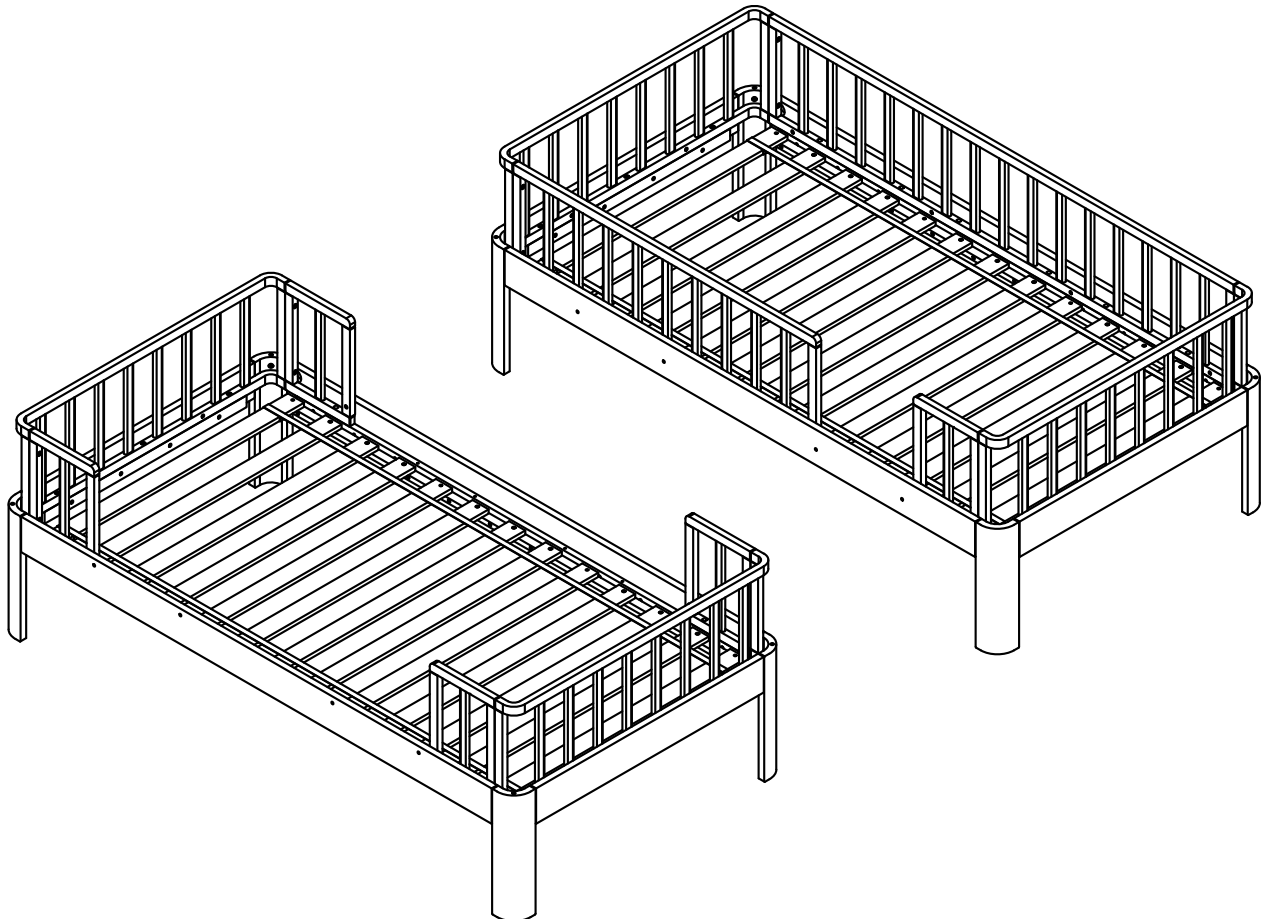

TWO SINGLE BEDS / DEUX LITS SIMPLES / DOS CAMAS INDIVIDUALES

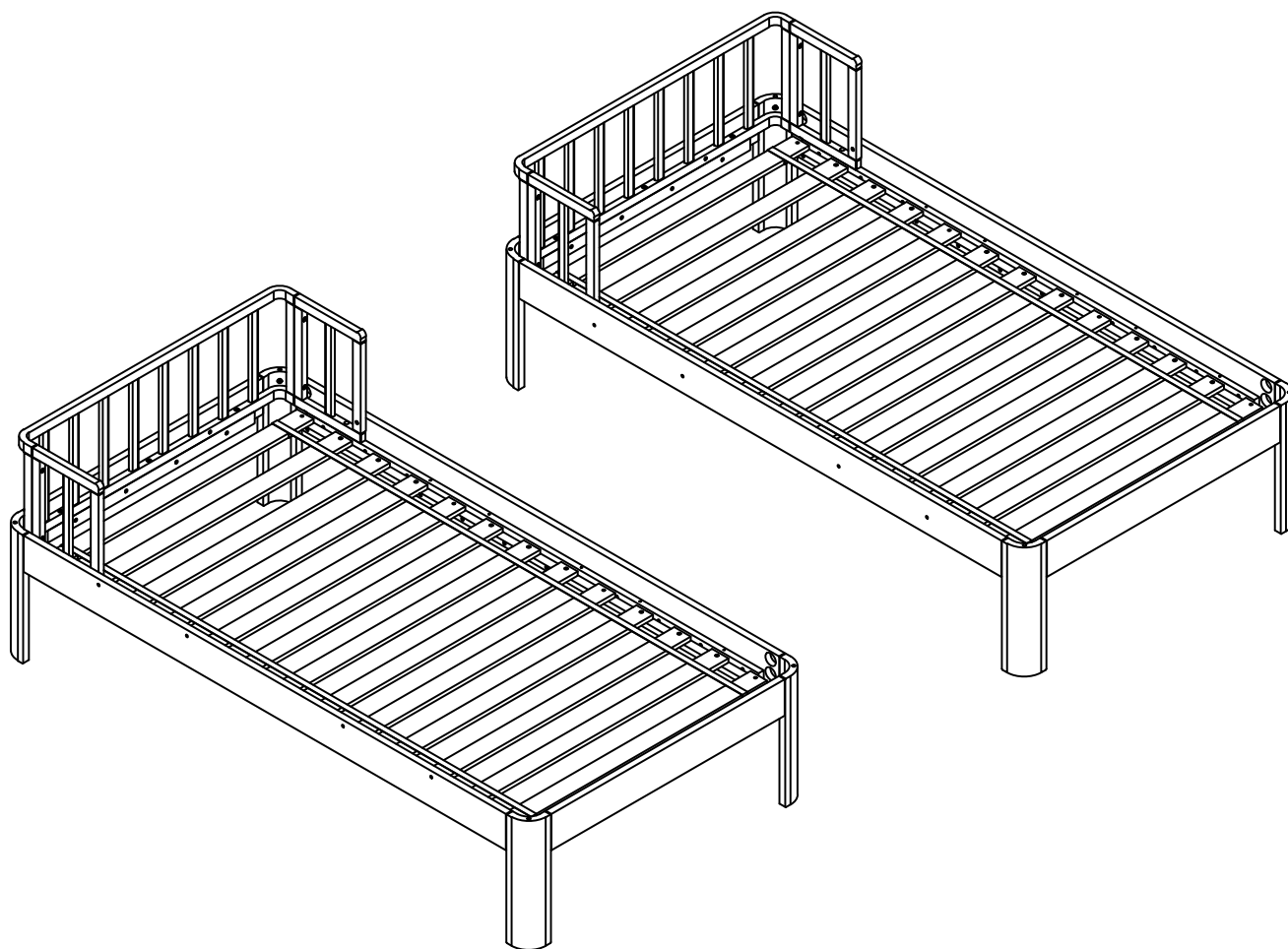

Identifying The Parts/Identification des pièces/ Identificación de piezas

ASSEMBLY TIPS

1. Remove hardware from box and sort by size.
2. Please check to see that all hardware and parts are present prior start of assembly.
3. Please follow attached instructions in the same sequence as numbered to assure fast and easy assembly.

WARNING!

1. Don't attempt to repair or modify part that are broken or defective. Please contact the store immediately.
2. This product is for home use only and not intended for commercial establishments.

RECOMENDACIONES DE ENSAMBLAJE

1. Retire el herraje de la caja y ordene por tamaño.
2. Por favor compruebe que todo el herraje y piezas estén listas antes del inicio del ensamble.
3. Por favor siga las instrucciones adjuntas en la misma secuencia numerada para asegurar un ensamblado rápido y fácil.

ADVERTENCIA!

1. No intente reparar o modificar si alguna pieza está rota o defectuosa. Por favor, póngase en contacto con la tienda de inmediato.
2. Este producto es para uso doméstico solamente y no destinado a establecimientos comerciales.

CONSEILS DE MONTAGE

1. Retirez le matériel de la boîte et de tri par taille.
2. Se il vous plaît vérifier que tout le matériel et les pièces sont présentes avant début de réunion .
3. Se il vous plaît suivre les instructions jointes dans la même séquence que numéroté pour assurer un montage rapide et facile .

ATTENTION!

1. À ne pas tenter de réparer ou de modifier une partie qui sont cassé ou défectueux. Se il vous plaît contactez immédiatement le magasin.
2. Ce produit est pour un usage domestique seulement et non destinés à des établissements commerciaux.



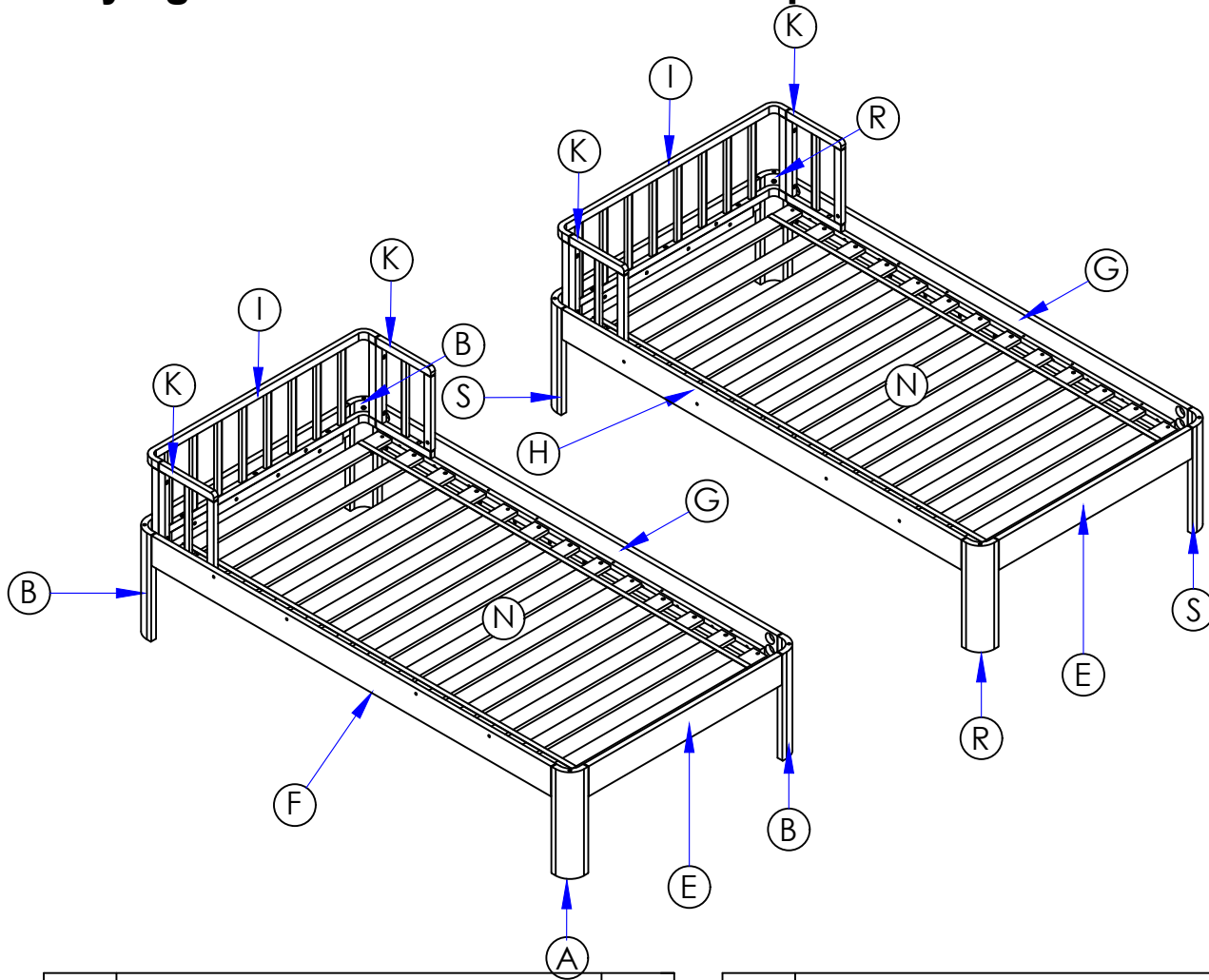











Identifying The Parts/Identification des pièces/ Identificación de piezas



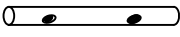

Part	Name Of Part List	Qty
A	Lower leg (Left rear & right front)	2pcs
B	Lower leg (Left front & right rear)	2pcs
C	Upper leg (Left rear & right front)	2pcs
D	Upper leg (Left front & right rear)	2pcs
E	Headboard/Footboard rail	4pcs
F	Lower front side rail	1pc
G	Upper & lower rear side rail	2pcs
H	Upper front side rail	1pc
I	Headboard/Footboard frame	2pcs
J	Headboard/Footboard frame with sticker	2pcs

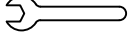
Part	Name Of Part List	Qty
K	Short guard frame	5pcs
L	Upper Front Guard Frame	1pc
M	Upper Rear Guard Frame	1pc
N	Slat	2sets
O	Right ladder rail	1pc
P	Left ladder rail	1pc
Q	Ladder stretcher	4pcs
R	Extra Lower Leg (Left Rear & Right Front)	2pcs
S	Extra Lower Leg (Right Rear & Left Front)	2pcs
T	Support rail	2pcs

HARDWARE PACK



NO.	DESCRIPTION		DIMENSION	QTY
1	Bolts		M6 x 60mm	8 pcs
2	Bolts		M6 x 40mm	24 pcs
3	Bolts		M6 x 16mm	16 pcs
4	Bolts		M6 x 40mm	27 pcs
5	Bolts		M6 x 28mm	16 pcs
6	Wood Screw		M4.0 x 28mm	56 pcs
7	JCN Nut		M6	8 pcs
8	Wood Dowel		Ø10 x 30mm	40 pcs
9	Barrel Nut		M6 x 13mm	8 pcs
10	Metal Pin With Hole		Ø10 x 100mm	4 pcs
11	Hanger Bolts		M8 x 60mm	24 pcs
12	H/M Washer		M8	24 pcs
13	H/M Nut		M8	24 pcs
14	Wrench		M8	1 pc
15	Allen Key		M4	1 pc

Step 1/ Étape 1/ Paso 1

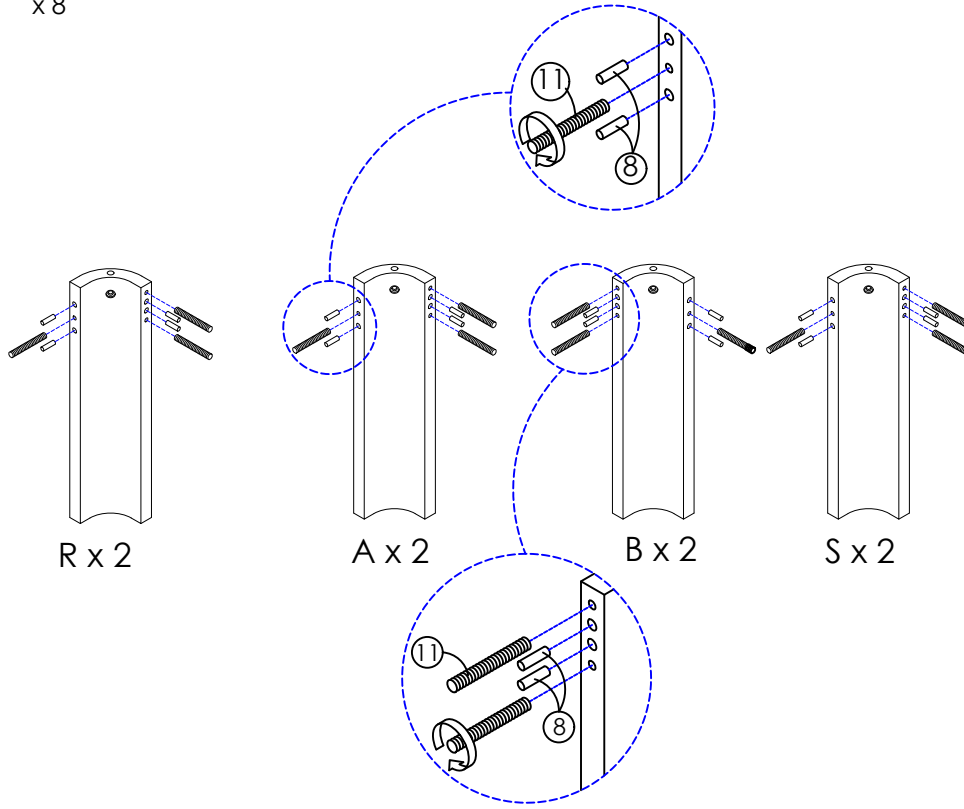
- ①  x 8
- ⑨  x 8



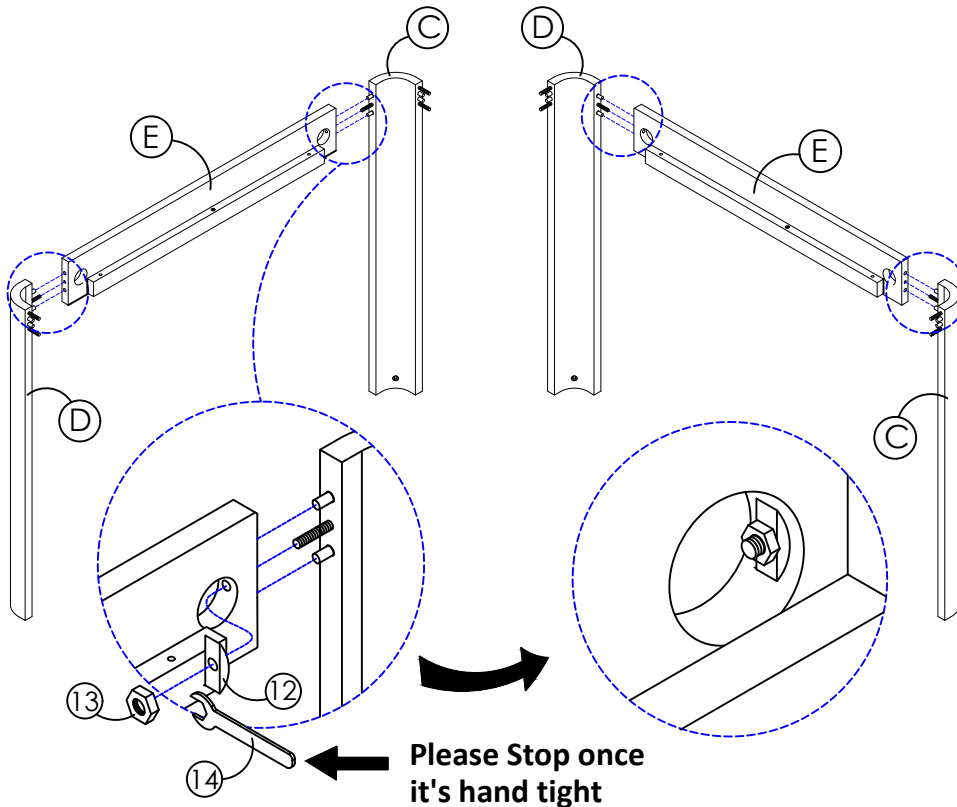

Step 2/ Étape 2/ Paso 2

- ⑫  x 4
- ⑬  x 4
- ⑭  x 1



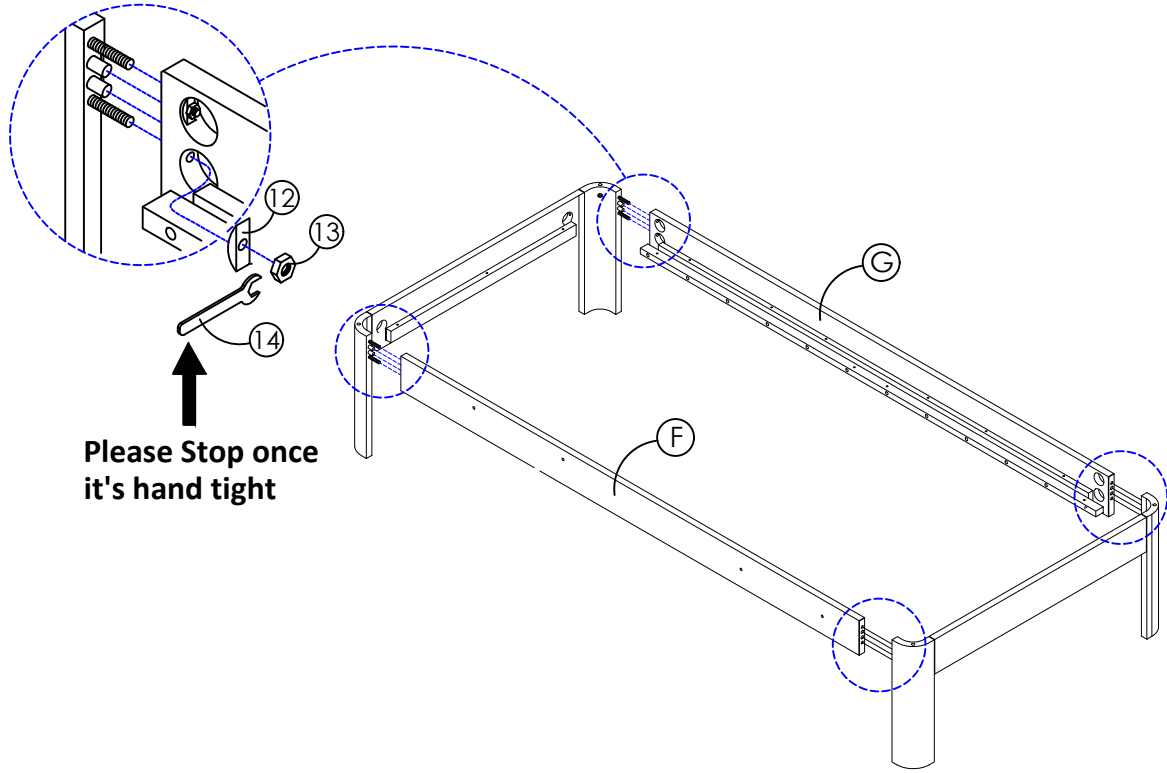

Step 3/ Étape 3/ Paso 3

- ⑫  x 8
- ⑬  x 8
- ⑭  x 1



Please Stop once it's hand tight

Step 4/ Étape 4/ Paso 4

- ②  x 8
- ⑮  x 1

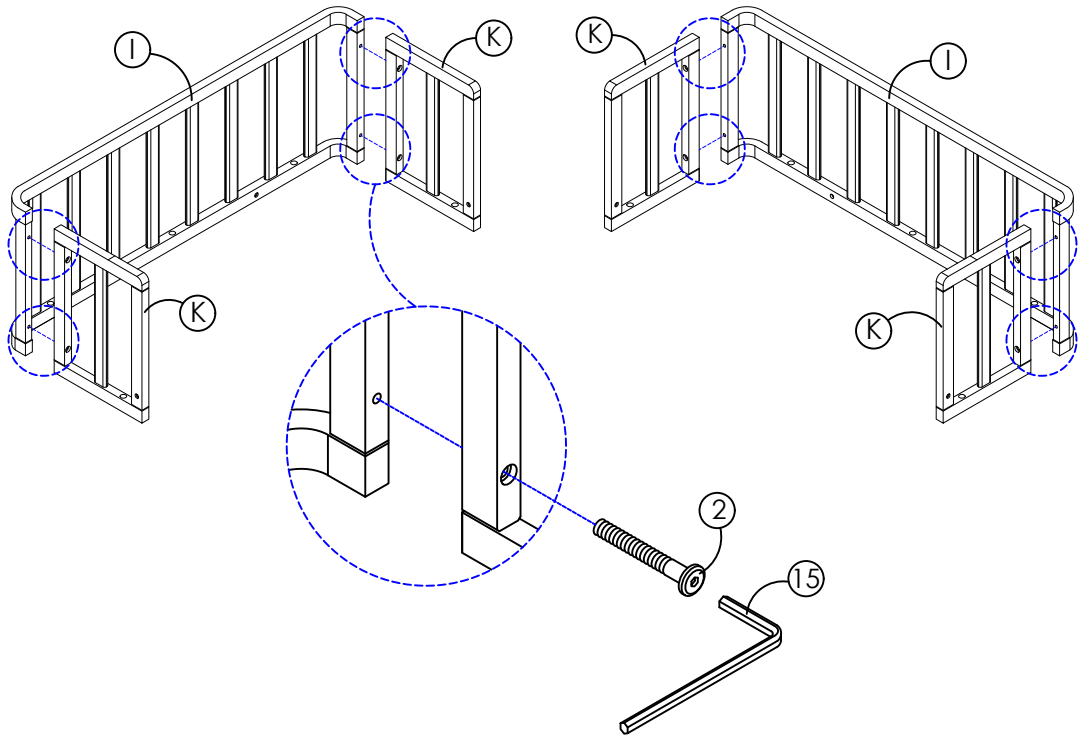

Step 5/ Étape 5/ Paso 5

④  x 5

⑮  x 1

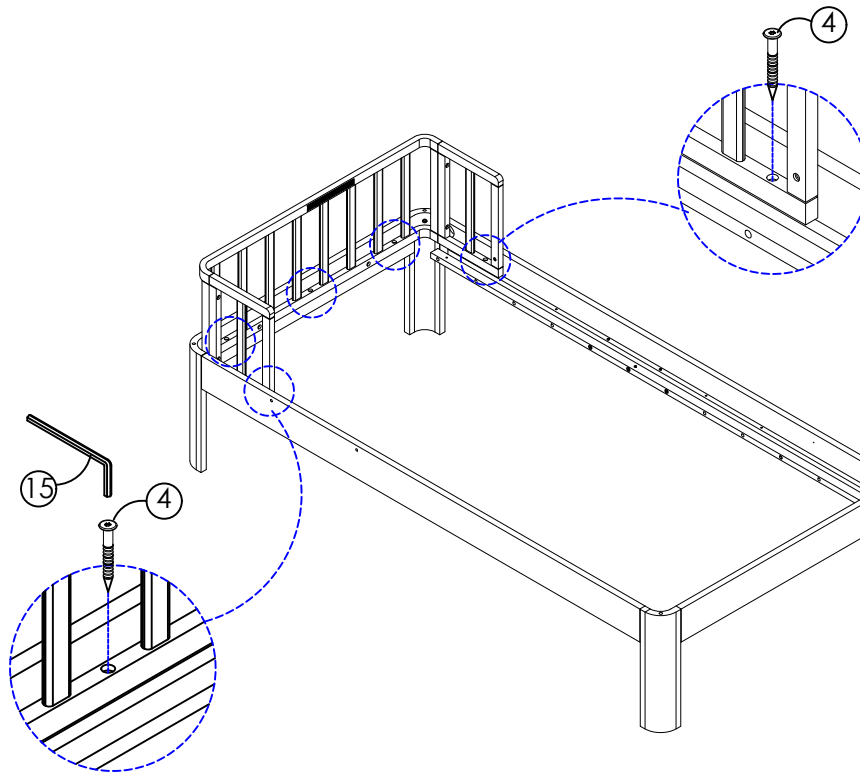

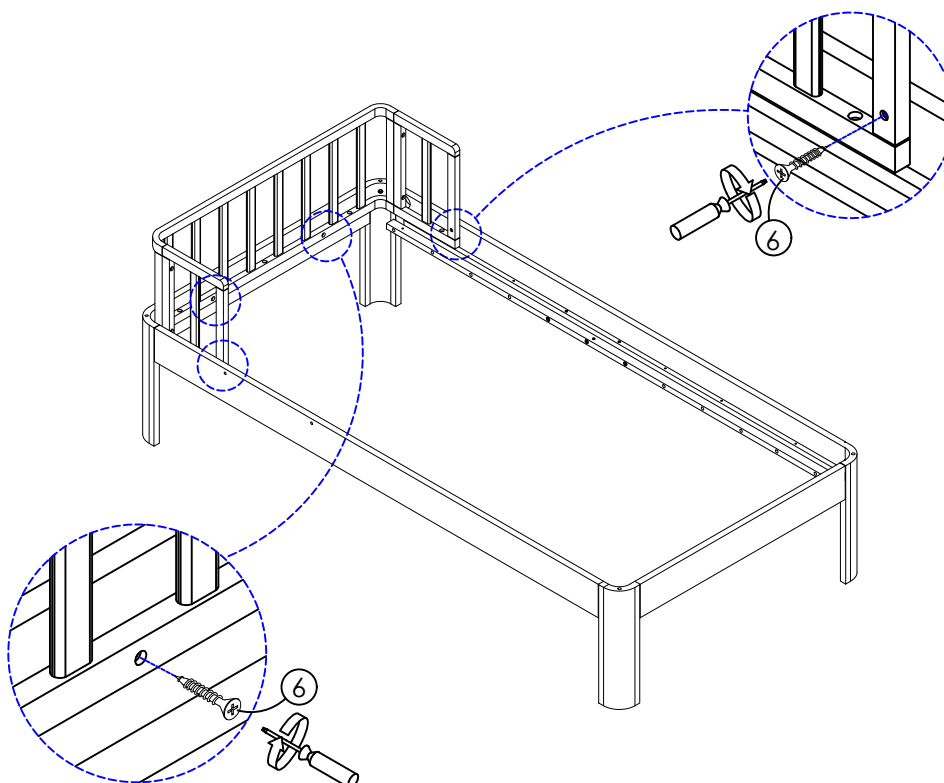

Step 6/ Étape 6/ Paso 6

⑥  x 4



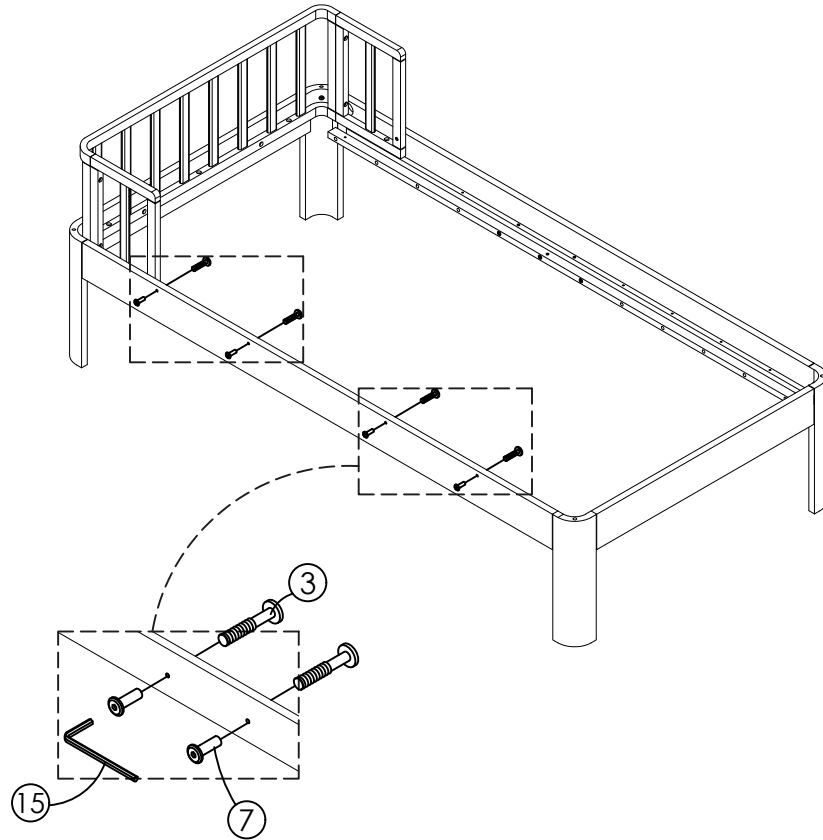

Step 7/ Étape 7/ Paso 7

- ③  x 4
- ⑦  x 4
- ⑮  x 1



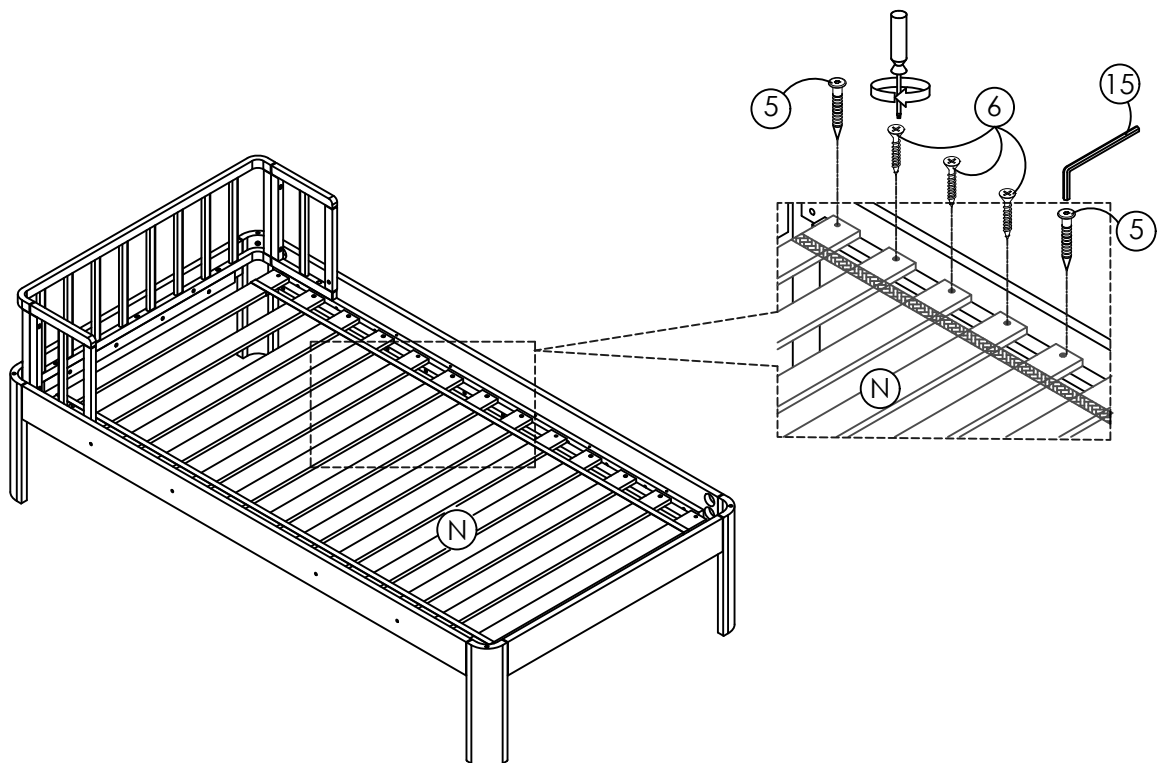

Step 8/ Étape 8/ Paso 8

- ⑥  x 18
- ⑤  x 8
- ⑮  x 1



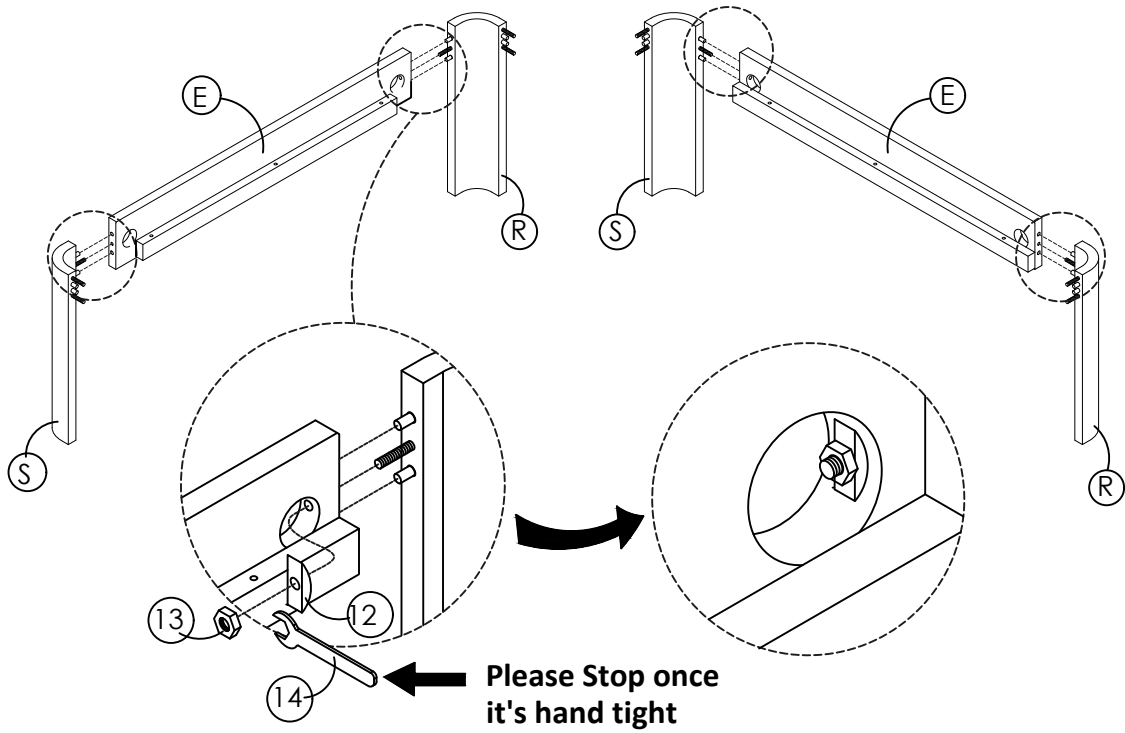

Step 9/ Étape 9/ Paso 9

- ⑫  x 4
- ⑬  x 4
- ⑭  x 1



Step 10/ Étape 10/ Paso 10

- ⑫  x 8
- ⑬  x 8
- ⑭  x 1

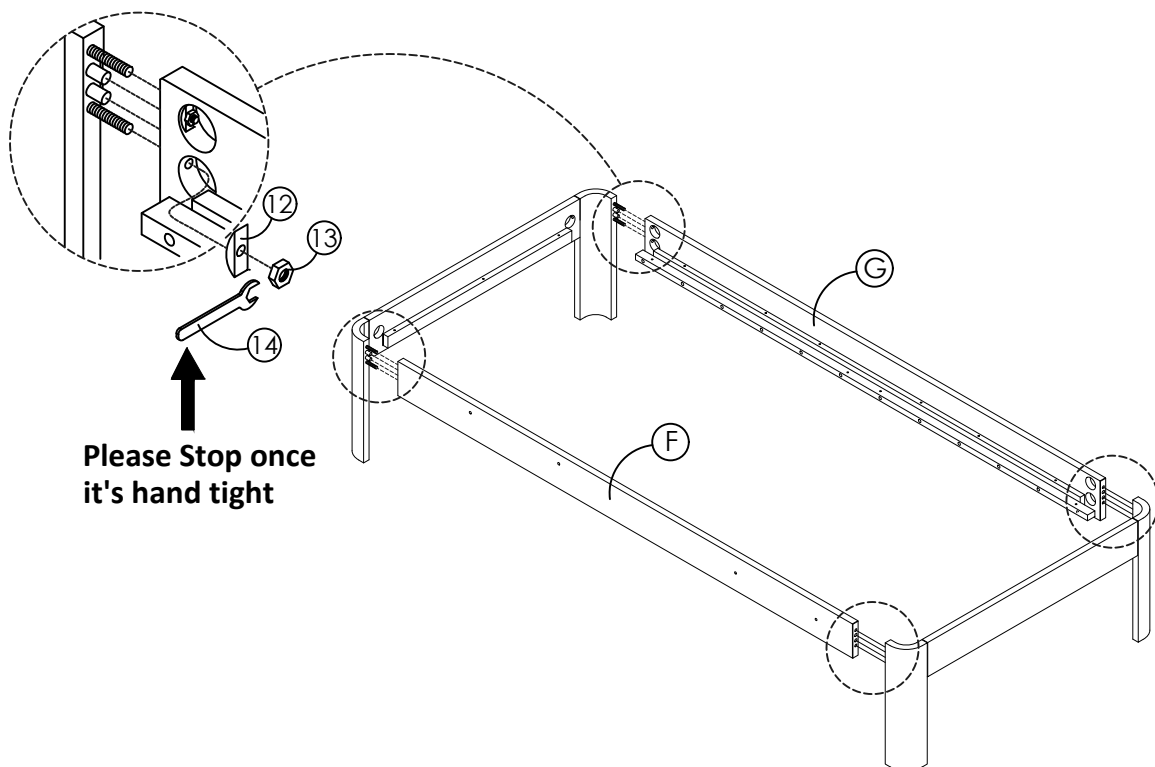

Step 11/ Étape 11/ Paso 11

④  x 5

⑮  x 1

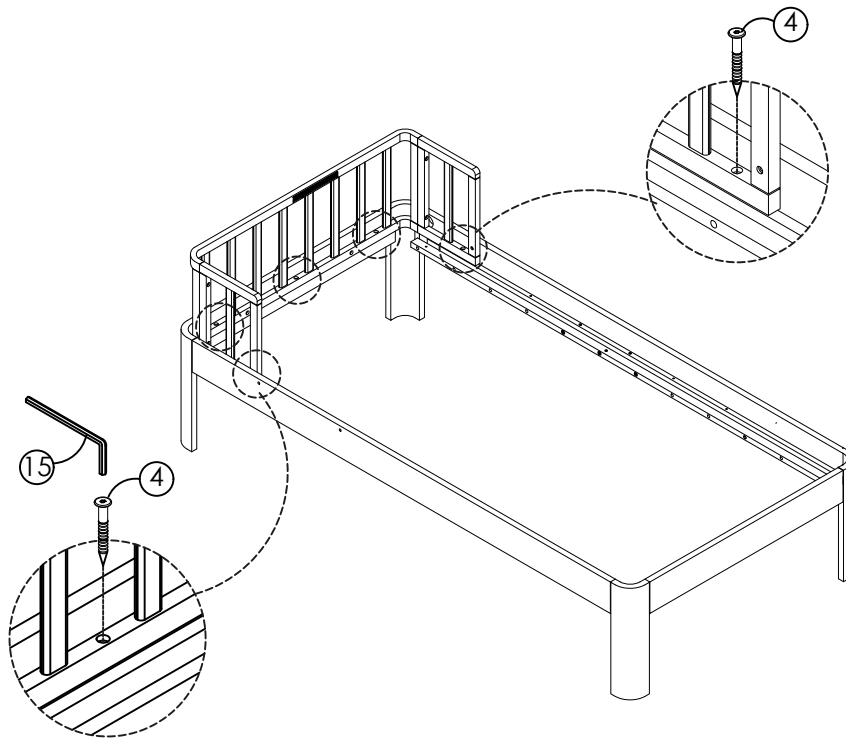

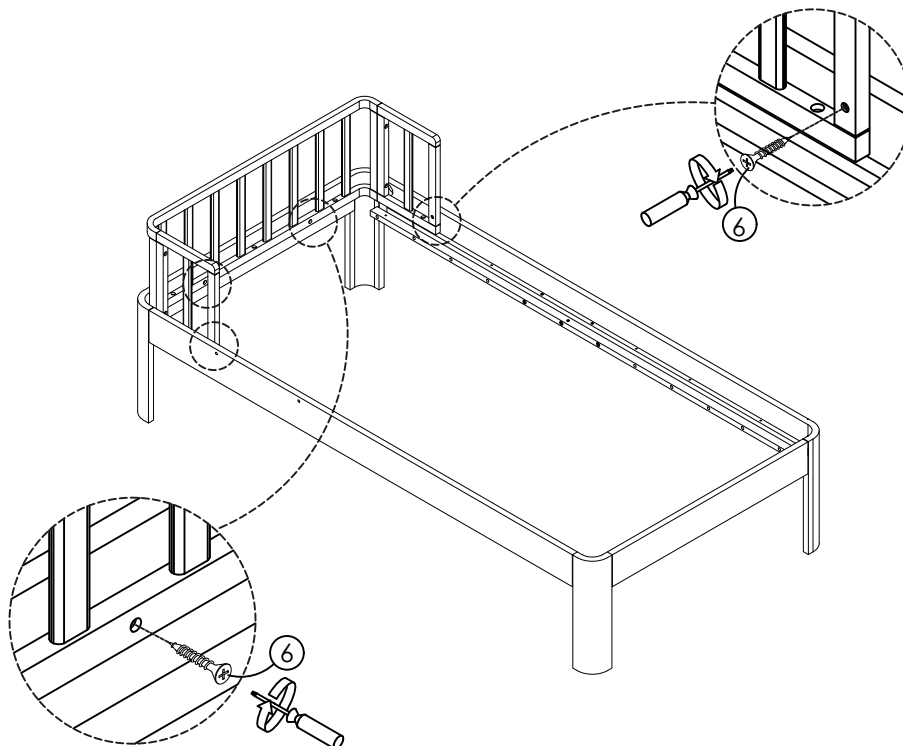

Step 12/ Étape 12/ Paso 12

⑥  x 4



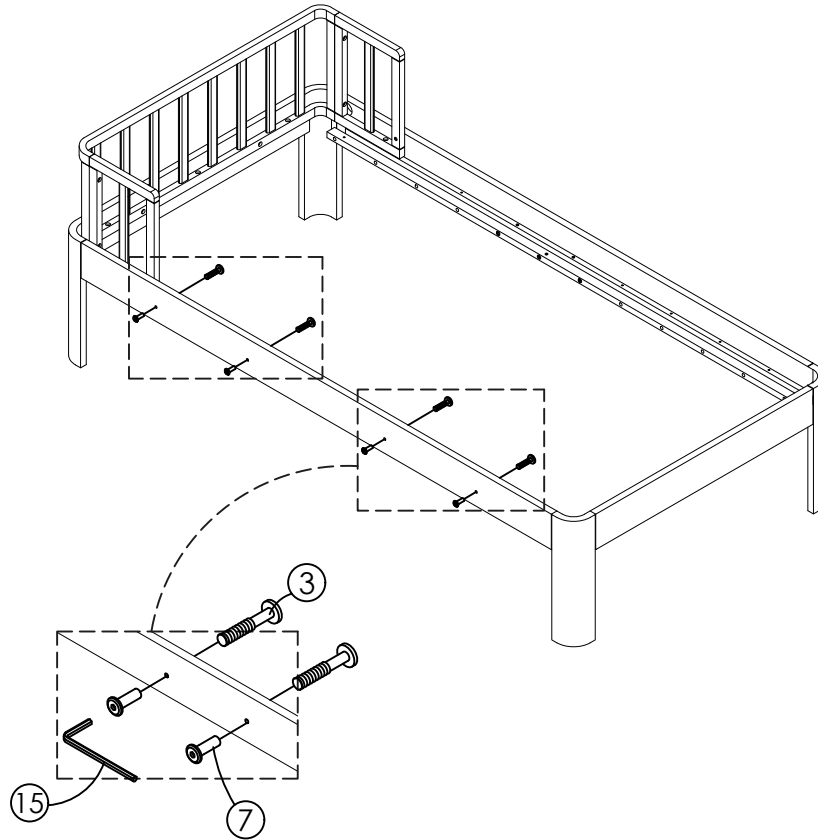

Step 13/ Étape 13/ Paso 13

- ③  x 4
- ⑦  x 4
- ⑮  x 1



Step 14/ Étape 14/ Paso 14

- ⑥  x 18
- ⑤  x 8

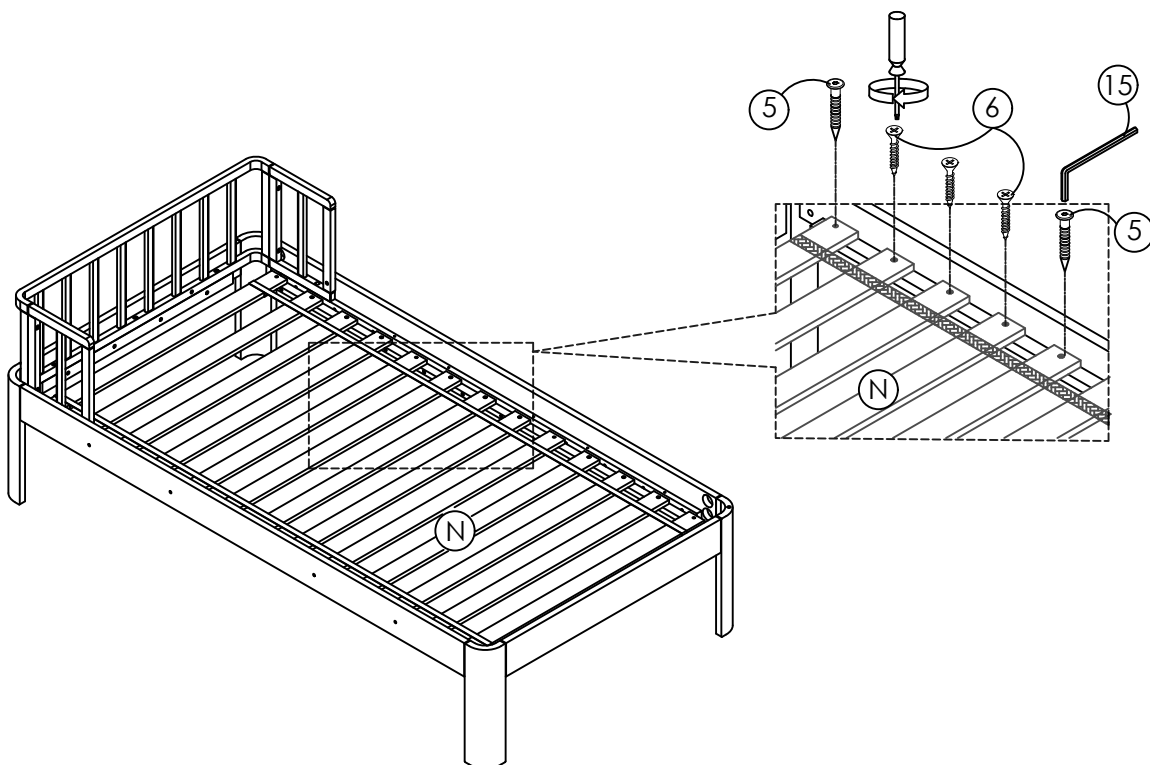

Step 15/ Étape 15/ Paso 15

COMPLETE ASSEMBLY FOR SINGLE BED & TODDLER BED

ASSEMBLAGE COMPLET POUR LIT SIMPLE ET LIT POUR TOUT-PETITS

MONTAJE COMPLETO PARA CAMA INDIVIDUAL Y CAMA PARA NIÑOS PEQUEÑOS

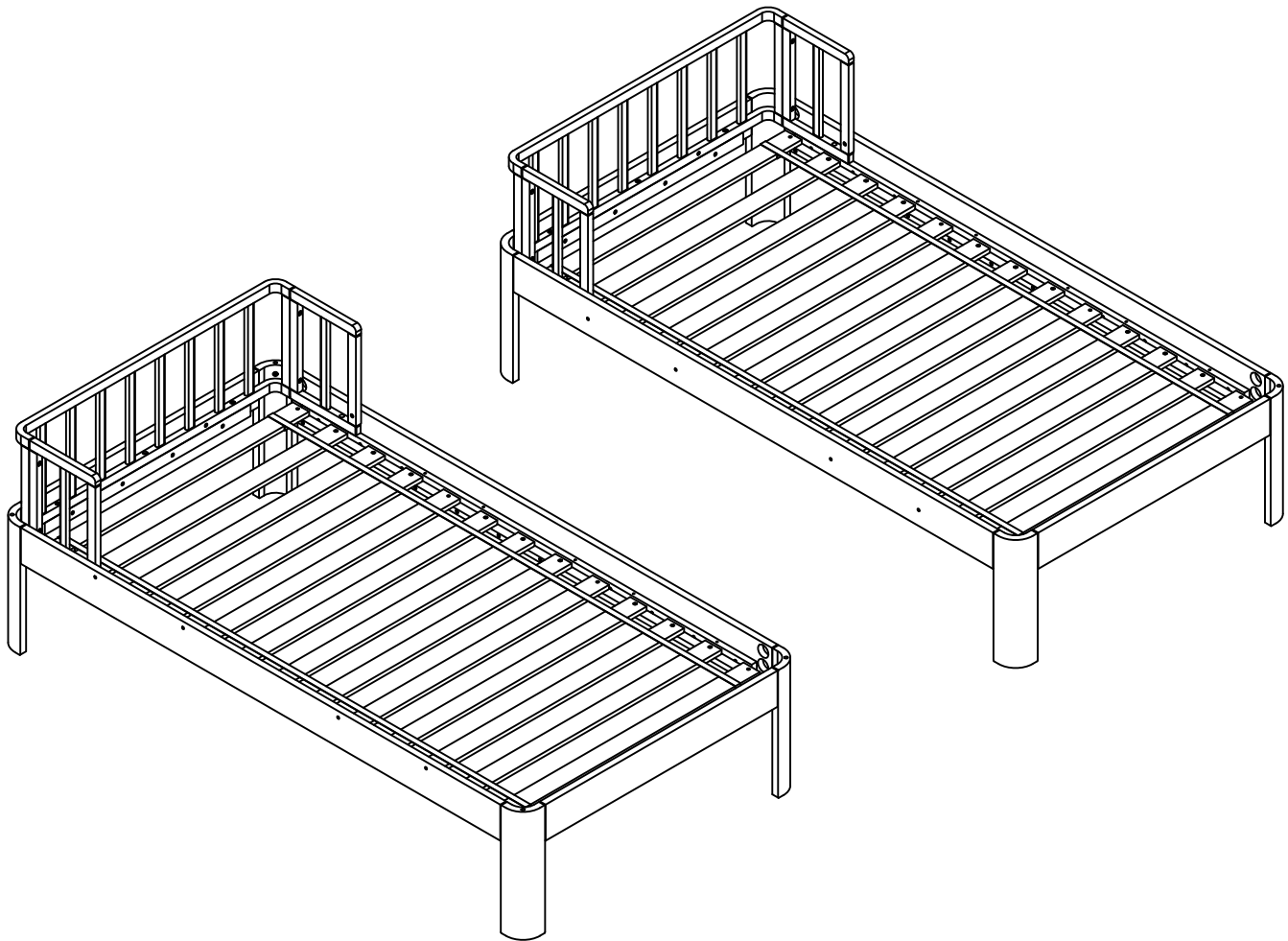

STORKCRAFT LIMITED WARRANTY

STORAGE AND CARE

DO NOT remove any part that is attached with wood screw. To disassemble, simply review the assembly instructions and reverse the order. Wipe all parts with a dampened cloth. Do not use abrasives.

LIMITED ONE YEAR WARRANTY

This one (1) year Limited Warranty ("Warranty") is a voluntary manufacturer' warranty. This Warranty supplies consumers with rights separate to those rights provided by applicable consumer law, including, but not limited to those applicable consumer laws relating to non-conforming goods. Accordingly, this Warranty shall not, in any way, limit, suspend, enlarge, nor restrict any rights provided by applicable law to any consumer. Notwithstanding any other terms, or conditions in this Warranty, all claims made under this Warranty shall be governed by the terms and conditions set forth in this Warranty document.

NOTE THAT BY USING YOUR STORKCRAFT PRODUCT YOU ARE AGREEING TO BE BOUND BY THE TERMS AND CONDITIONS OF THIS WARRANTY. IF YOU DO NOT AGREE WITH THE TERMS OF THIS WARRANTY, THEN DO NOT USE THIS STORKCRAFT PRODUCT AND CONTACT STORKCRAFT' CUSTOMER CARE DEPARTMENT.

I. WARRANTY LIMITATIONS AND TIME PERIOD:

Storkcraft Manufacturing Inc. warrants this product against defects in the materials and workmanship of the same, when used normally by consumer pursuant to Storkcraft's Guidelines (as defined), for a period of one (1) year from the date of the original retail purchase (such to be the "arranty Period". Storkcraft' Guidelines include, but are not limited to product technical specifications, product or user manuals, product service announcements and communications (printed or circulated). Prior to any consumer receiving any benefits under this Warranty, Storkcraft and/or its agents may: (a) demand the production of proof of purchase by the consumer; (b) require consumer to follow additional instructions or procedures to obtain benefits under this Warranty; and/or (c) require consumer to answer questions or verify product information (including, but not limited to requests for photographs).

II. WARRANTY SERVICE:

Storkcraft will replace parts or products, at its sole option, from any defective product. Service under this Warranty shall be rendered in the manner deemed appropriate by Storkcraft in its own judgment, and Storkcraft may, at its sole discretion, require consumer to mail or ship items or products. Storkcraft may supply consumer with parts or hardware for consumer' own/do-it-yourself ("IY" installation. DIY parts and hardware will only be shipped within the Continental United States or Canada, pursuant to all applicable laws and regulations. Customers outside of these areas may be subject to additional shipping charges. Storkcraft shall not be responsible for labor or other costs incurred by consumer in connection with DIY installations. Notwithstanding the foregoing, Storkcraft reserves the right to: (a)

Distributed by

Storkcraft Manufacturing Inc. 3993 Howard Hughes Parkway, Unit# 250
Las Vegas, NV, USA. 89169

change the method by which Storkcraft will accept consumer repair or replacement requests under this Warranty; (b) limit, modify, restrict, or enlarge consumer rights based on applicable law; (c) charge shipping, handling, or other charges in connection with supplied parts or hardware; and/or (d) require the return of defective products, parts, or hardware. Storkcraft may replace any parts or hardware with similar and/or equal quality parts or hardware.

III. LIMITATIONS ON LIABILITY:

Except as provided for in this Warranty, and only to the maximum extent permitted by applicable law, Storkcraft shall not be responsible for direct, special, incidental, or consequential damages that may result from, or which flow from, any breach of warranty or condition, and/or that may be asserted using any legal theory. This Warranty is specifically disclaimed to second-hand purchasers of any products. This Warranty shall further not apply in instances of product abuse, product misuse, product neglect, commercial use of such products, or due to accidental damage and/or natural forces. The foregoing limitations shall be modified or removed in any state, country, or province that does not permit such limitations (and only to the minimum extent that such are prohibited by law).

IV. GENERAL TERMS:

If any term or condition of this Warranty is deemed to be illegal or unenforceable, then the legality and enforceability of the other terms and conditions of this Warranty shall be unaffected. No agent, employee, reseller, nor other individual or company shall be permitted without specific written authorization to modify or otherwise change this Warranty. This Warranty shall be construed and governed by the laws of the country, state, or province where the subject purchase of the product occurred.

V. PROCEDURE FOR OBTAINING WARRANTY SERVICE:

Consumer may obtain Warranty Service by contacting Storkcraft' Customer Care department through the channels listed below.

Storkcraft Website: www.storkcraftdirect.com

Email: customercare@storkcraft.com

Phone Toll Free: 1-877-274-0277

Hours of Operation: 6:30 am - 4:00 pm PST / 9:30 am- 7:00 pm EST

- Mon to Fri

T: 1 877 274 0277 | E: customercare@storkcraft.com | Twitter @Storkcraft

GARANTIE LIMITÉE STORKCRAFT

DÉMONTAGE DU LIT DE BEBE

NE PAS démonter les pièces attaché avec des vises a bois. Pour démonter veuillez suivre les instructions de montages au reverse. Nettoyer a l'aide d'un chiffon humide, ne jamais utiliser de produit abrasifs.

GARANTIE LIMITEE D'UN AN/

Cette garantie limitée d'un (1) an («Garantie») est une garantie volontaire du fabricant. Cette garantie fournit aux consommateurs des droits distincts de ceux prévus par la législation applicable en matière de consommation, y compris, mais sans s'y limiter, les lois de protection aux consommateurs applicables aux produits non conformes. En conséquence, cette garantie ne doit en aucun cas limiter, suspendre, élargir ou restreindre les droits prévus par la loi applicable à tout consommateur. Nonobstant toute autre termes ou conditions de cette Garantie, toutes les réclamations faites en vertu de cette Garantie seront régies par les termes et conditions énoncés dans ce document de Garantie.

NOTEZ QU'EN UTILISANT VOTRE PRODUIT STORKCRAFT VOUS ACCEPTEZ D'ETRE LIE PAR LES TERMES ET CONDITIONS DE CETTE GARANTIE. SI VOUS N'ACCEPTEZ PAS LES TERMES DE CETTE GARANTIE, ALORS N'UTILISEZ PAS CE PRODUIT ET DE CONTACTER LE SERVICE A LA CLIENTELE DE STORKCRAFT.

I. LIMITES DE GARANTIE ET PÉRIODE DE TEMPS:

Storkcraft Manufacturing Inc. garantit ce produit contre les défauts de matériaux et de fabrication de celui-ci, lorsqu'il est utilisé normalement par le consommateur conformément aux lignes directrices de Storkcraft (tel que défini), pour une période d'un (1) an de la date d'achat d'origine (définie comme la «période de garantie»). Les lignes directrices de Storkcraft incluent, mais ne sont pas limitées aux spécifications techniques de produit, aux manuels de produit ou d'utilisateur, aux annonces de service de produit et aux communications (imprimées ou distribuées). Avant que tout consommateur ne reçoive des avantages en vertu de cette garantie, Storkcraft et / ou ses agents peuvent: (a) exiger une preuve d'achat par le consommateur; (b) exiger que le consommateur suive des instructions ou des procédures supplémentaires pour obtenir des avantages en vertu de la présente garantie; et / ou (c) exiger que le consommateur réponde à des questions ou vérifie les informations sur le produit (y compris, mais sans s'y limiter, des demandes de photographies)

II. SERVICE DE GARANTIE:

Storkcraft remplacera les pièces ou les produits, à sa seule discrétion, contre tout produit défectueux. Le service fourni dans le cadre de cette garantie doit être effectué de la manière jugée appropriée par Storkcraft selon son propre jugement, et Storkcraft peut, à sa seule discrétion, exiger que le consommateur expédie ou expédie des articles ou des produits. Storkcraft peut fournir au consommateur des pièces de remplacement ou de la quincaillerie qui seront installer par lui-même ou elle-même. Les pièces de remplacement

et la quincaillerie ne seront expédiées qu'à l'intérieur du territoire continental américain et du Canada. conformément à toutes les lois et à tous les règlements applicables. Les clients situés à l'extérieur de ces zones pourraient être sujet à des frais de livraison supplémentaires. Storkcraft ne sera pas responsable des coûts de main-d'œuvre ou autres coût engendrés par le consommateur dans le cadre de son installation. Nonobstant ce qui précède, Storkcraft se réserve le droit de: (a) modifier la méthode par laquelle Storkcraft acceptera les demandes de réparation ou de remplacement du consommateur en vertu de la présente garantie; (b) limiter, modifier, restreindre ou élargir les droits des consommateurs en fonction de la loi applicable; (c) facturer des frais d'expédition, de manutention ou autres en rapport avec les pièces ou la quincaillerie fournis; et / ou (d) exiger le retour de produits, de pièces ou de quincaillerie défectueux. Storkcraft peut remplacer des pièces ou quincailleries avec des pièces ou quincailleries de qualité similaire et ou de qualité équivalente.

III. LIMITATIONS DE RESPONSABILITÉ :

À l'exception de ce qui est prévu dans la présente garantie et uniquement dans la mesure maximale permise par la loi applicable, Storkcraft ne peut être tenu responsable des dommages directs, spéciaux, accidentels ou consécutifs pouvant résulter ou découler d'une violation de la garantie ou de la condition, et/ou qui peut être affirmé en utilisant n'importe quelle théorie juridique. Cette garantie est expressément exclue pour les deuxièmes acheteurs de tout produit. Cette garantie ne s'applique en outre pas dans les cas d'abus de produit, de mauvaise utilisation du produit, de négligence du produit, d'utilisation commerciale de tels produits, ou de dommages accidentels et / ou de forces naturelles. Les limitations ci-dessus doivent être modifiées ou supprimées dans tout état, pays ou province qui n'autorise pas de telles limitations (et seulement dans la mesure minimale où cela est interdit par la loi).

IV. TERMES GÉNÉRAUX

Si une condition de cette garantie est jugée illégale ou inapplicable, alors la légalité et l'applicabilité des autres termes et conditions de cette garantie ne seront pas affectées. Aucun agent, employé, revendeur, ni aucune autre personne ou entreprise ne sera autorisé sans autorisation écrite spécifique pour modifier ou autrement changer cette garantie. Cette garantie doit être interprétée et régie par les lois du pays, de l'état ou de la province où le produit en question a été acheté.

V. PROCÉDURE D'OBTENTION DU SERVICE DE GARANTIE

Le consommateur peut obtenir un service de garantie en contactant le service à la clientèle de Storkcraft par les canaux indiqués ci-dessous.

Site web de Storkcraft: www.storkcraftdirect.com

Courriel: customer-care@storkcraft.com

Téléphone sans frais: 1-877-274-0277

Heures d'ouverture: 6:30 – 4:00 (HNP) / 9:30 – 7:00 (HNE) - lundi au vendredi

Distributed by

Storkcraft Manufacturing Inc. 3993 Howard Hughes Parkway, Unit# 250
Las Vegas, NV, USA. 89169

T: 1 877 274 0277 | E: customer-care@storkcraft.com | Twitter @Storkcraft

GARANTIA LIMITADA STORKCRAFT

ALMACENAMIENTO Y CUIDADO

NUNCA desmantelar las piezas adjuntadas con tornillos para maderas. Para desmantelar, seguir las instrucciones de ensamblaje al revés. Para limpiar utilizar un paño húmedo. Nunca utilice productos abrasivos.

UN AÑO DE GARANTÍA LIMITADA

Esta garantía limitada de un (1) año ("Garantía") es una garantía voluntaria del fabricante. Esta garantía proporciona a los consumidores derechos separados, a los derechos otorgados por la legislación aplicable a la ley del consumidor, incluyendo, pero no limitado a las leyes del consumidor aplicables que estén relacionadas a los productos no conformes. En consecuencia, esta garantía no deberá, en modo alguno, limitar, suspender, ampliar ni restringir cualquiera de los derechos previstos por la legislación vigente para cualquier consumidor. Sin perjuicio de otros términos o condiciones de esta garantía, todas las reclamaciones hechas bajo esta garantía se regirán por los términos y condiciones estipulados en este documento.

TENGA EN CUENTA QUE UTILIZANDO SU PRODUCTO STORKCRAFT USTED ACEPTA QUEDAR OBLIGADO POR LOS TERMINOS Y CONDICIONES DE ESTA GARANTIA. SI USTED NO ESTÁ DE ACUERDO CON LOS TÉMINOS DE ESTA GARANTIA, NO UTILICE ESTE PRODUCTO STORKCRAFT Y PÓNGASE EN CONTACTO CON EL DEPARTAMENTO DE ATENCIÓN AL CLIENTE.

I. LIMITACIONES DE LA GARANTÍA Y PERIODO DE TIEMPO:

Storkcraft Manufacturing Inc. garantiza este producto contra defectos en los materiales y la mano de obra de la misma, cuando usado normalmente por los consumidores conforme a las directrices de Storkcraft (definidos), por un período de un (1) año desde la fecha original de compra (Tal Será "período de garantía"). Las directrices de Storkcraft incluyen, pero no están limitados a las especificaciones técnicas del producto, Manuales de usuario o producto, anuncios y comunicaciones (impreso o distribuido). Antes de que cualquier consumidor reciba beneficios bajo esta garantía, Storkcraft y/o sus agentes período : a) exigir la presentación de la prueba de compra por parte del consumidor ; b) exigir al consumidor seguir instrucciones o procedimientos adicionales para obtener beneficios bajo esta garantía ; y/o (c) Requerir al consumidor responder preguntas o verificar la información del producto (incluyendo, pero no limitado a las peticiones de fotografías).

II. SERVICIO DE GARANTIA:

Storkcraft reemplazará las piezas, de cualquier producto defectuoso, a su discreción. El servicio bajo esta garantía será prestado de la manera que Storkcraft considere adecuada en su propio juicio y Storkcraft puede, a su discreción, requerir al consumidor enviar correos electrónicos o enviar artículos y/o

productos. Storkcraft puede suministrar al consumidor con piezas para que el propio consumidor las instale. Las piezas sólo serán enviadas dentro de los Estados Unidos Continentales o Canadá, de acuerdo con todas las leyes y regulaciones aplicables. Los clientes fuera de estas áreas pueden estar sujetos a cargos adicionales de envío. Storkcraft no será responsable de la mano de obra u otros gastos incurridos por los consumidores en relación con las instalaciones de las piezas. No obstante lo anterior, Storkcraft se reserva el derecho a : (a) modificar el método mediante el cual Storkcraft aceptará solicitudes de reparación o sustitución de consumo bajo esta garantía; b) limitar, modificar, restringir o ampliar los derechos de los consumidores basándose en la ley aplicable; c) los gastos de manipulación, envío de carga u otros cargos en relación con las piezas suministradas; y/o (d) requerir la devolución de las Piezas o productos defectuosos. Storkcraft podría sustituir piezas con otras de similar y/o igual calidad.

III. LIMITACIONES DE RESPONSABILIDAD:

Salvo en los casos previstos en esta garantía, y sólo en la máxima medida permitida por la ley aplicable, Storkcraft no será responsable de daños directos, especiales, incidentales o consecuentes que puedan resultar de, o que se derivan de, cualquier incumplimiento de la garantía o condición, y/o que puede ser reclamada mediante cualquier teoría legal. Esta garantía queda expresamente excluida a compradores de segunda mano de cualquiera de los productos. Esta garantía no se aplicará en casos de abuso, uso negligente, malhuso y/o uso comercial de dichos productos, o debido a daños accidentales y/o fuerzas naturales. Las limitaciones anteriores deberán ser modificadas o retiradas en cualquier estado, país o provincia que no permite tales limitaciones (y únicamente en la mínima medida que tales estén prohibidas por la ley).

IV. TERMINOS GENERALES:

Si cualquier término o condición de esta garantía se considera ilegal o inaplicable, entonces la legalidad y aplicabilidad de los demás términos y condiciones de esta garantía no se verán afectados. Ningún agente, empleado, distribuidor, ni otra persona o empresa, será permitida sin autorización específica por escrito a modificar o cambiar esta garantía. Esta garantía será interpretada y se regirá por las leyes del país, estado o provincia donde se produjo la compra del producto.

V. PROCEDIMIENTO PARA LA OBTENCIÓN DEL SERVICIO DE GARANTÍA:

El consumidor puede obtener el servicio de garantía contactando al departamento de Atención al cliente de Storkcraft a través de los canales indicados a continuación.

Storkcraft sitio web: www.storkcraftdirect.com

Correo electrónico: customercare@storkcraft.com

Teléfono (Línea gratuita): 1-877-274-0277

Horario: 6:30 am –4:00 pm PST / 9:30 am –7:00 pm EST,

de lunes a viernes

Distributed by

Storkcraft Manufacturing Inc. 3993 Howard Hughes Parkway, Unit# 250
Las Vegas, NV, USA. 89169

T: 1 877 274 0277 | E: customercare@storkcraft.com | Twitter @Storkcraft