

BLACK DIAMOND®

Project Name: _____

Location: _____

Item #: _____

Qty: _____

Black Diamond Gas Deep Fryer, 60 lb, Freestanding, 5 Burner, 105k BTU, in Stainless Steel

BDGF-ES60-LP



The Black Diamond 60 lb Gas Deep Fryer delivers fast, efficient frying for high-volume kitchens with durable stainless steel and cast iron construction. With five burners generating 105,000 BTU, manual ignition, and simple knob controls, this freestanding fryer provides reliable performance and consistent results. The large capacity and multiple included accessories make it ideal for demanding operations, supporting superior productivity and easy operation. Covered by the manufacturer's limited warranty for added confidence.

FEATURES AND CONSTRUCTION

- Best-in-class, energy-efficient design with Energy Star Certification
- Constructed from heavy-duty stainless steel with cast iron burners for lasting commercial durability
- Delivers 105,000 BTU output for rapid heat-up and consistent frying performance
- Equipped with five cast iron burners for even heat distribution and high-volume output
- Manual knob controls ensure precise, user-friendly operation
- Operates using LP gas for reliable and efficient energy use
- Designed as a freestanding unit for flexible installation in commercial kitchens
- Features manual ignition for dependable burner lighting and an automatic shut-off for safety
- Accommodates a wide temperature range to support diverse frying applications

FRYER ACCESSORIES (OPTIONAL)

- Stainless Steel Cover
- Joiner Strips
- Splash Guard
- Fryer baskets available in a variety of sizes

3RD PARTY APPROVALS



WARRANTY (USA / CANADA)

One (1) Year Limited Warranty on Parts and Labor, Five (5) Year Warranty on Stainless Steel Fry Tank

Contact us for details at 1.877.368.2797



INCLUDED COMPONENTS

- (4) Casters
- (2) Baskets
- (2) Basket Support Rack
- (1) Basket Hanging Plate
- (1) Oil Drainage Extension Pipe

TEMPERATURE

Overall Temperature (Fahrenheit):

- Minimum: 200° - Maximum: 400°F



Black Diamond Gas Deep Fryer Freestanding

BDGF-ES60-LP

FRONT

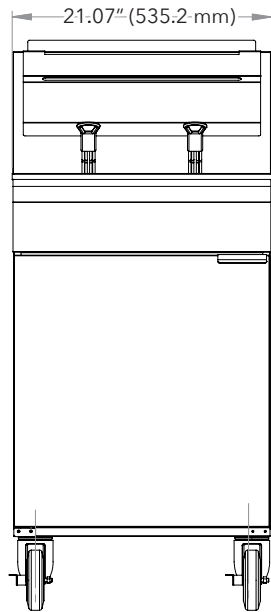

SIDE

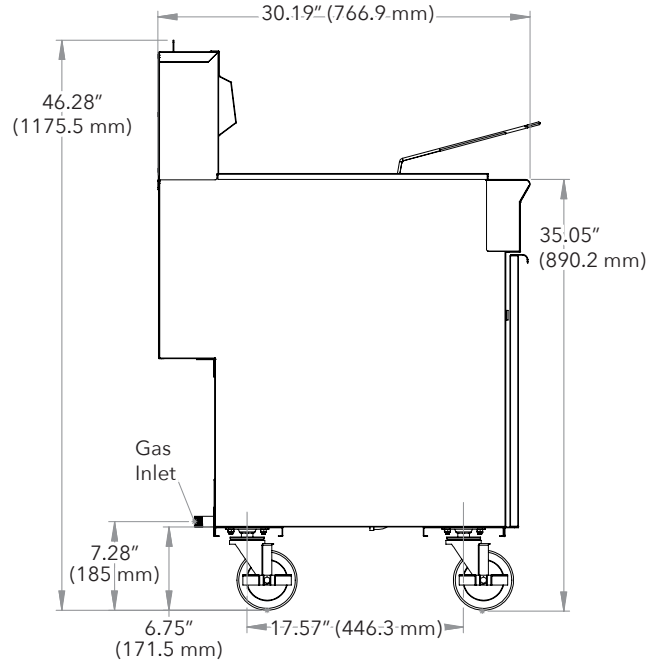

TOP

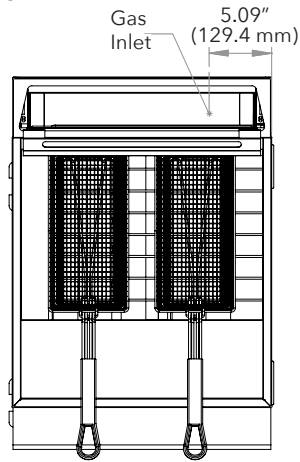

Gas

Capacity (lbs. of oil)	Temperature Range (Fahrenheit)	BTU / Hour	Assembled Dimensions (in)	Item Weight (lbs)	Shipping Weight (lbs)
60 lb	200° - 400°	105000	30.19" x 21.07" x 46.28"	176.4	205.1

ADDITIONAL INFORMATION

- Electricity not needed.
- Liquid Propane (LP) or Natural Gas (NG) units available. Field convertible from LP to NG and vice versa.
- Minimum supply pressure is 4" W.C. for natural gas and 10" W.C. for propane.
- Gas powered appliances must always be indoors, under an approved exhaust system with grease removal filters and a fire protection system.

Due to periodic changes in designs, methods, procedures, policies and regulations, the specifications contained in this document are subject to change without notice. While we exercise good faith efforts to provide information that is accurate, we are not responsible for errors or omissions in information provided or conclusions reached as a result of using the specifications. By using the information provided, the user assumes all risks in connection with such use.