



Z415C

BODY ASSEMBLY W/ "TYPE C" STRAINER

SPECIFICATION SHEET

TAG _____

Dimensional Data (inches and [mm]) are Subject to Manufacturing Tolerances and Change Without Notice

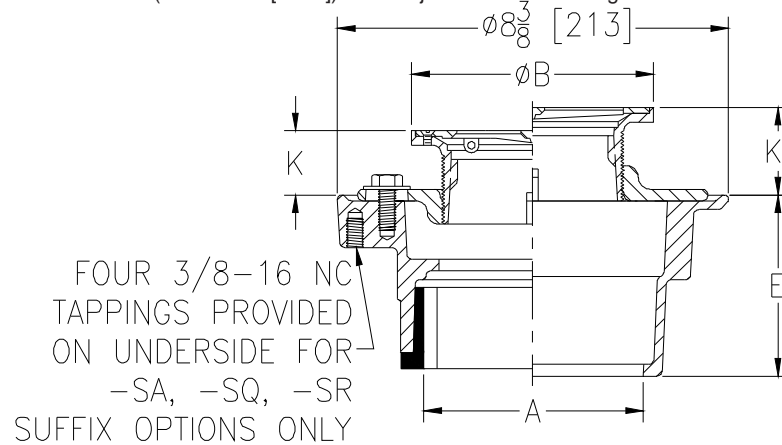

Dimensions In Inches						Approx. Wt. Lbs. [kg]	Strainer Open Area Sq. In. [cm ²]
A - Pipe Size	B Strainer Dia.	K		K'			
		Min.	Max.	Min.	Max.		
2-3 [51-76]	5 [127]	1 [25]	1-1/2 [38]	1-3/32 [28]	2-1/4 [57]	11 [5]	8 [52]
2-3-4 [51-76-102]	6 [152]	1 [25]	1-25/32 [45]	1-13/32 [36]	2-17/32 [64]	13 [6]	9 [58]
2-3-4 [51-76-102]	7 [178]	1 [25]	2-1/8 [54]	1-23/32 [44]	2-7/8 [73]	14 [6]	13 [84]
3-4 [76-102]	8 [203]	1-5/32 [29]	2-1/8 [54]	1-3/4 [44]	2-7/8 [73]	16 [7]	18 [116]
6 [152]	8 [203]	1-5/32 [29]	2-1/8 [54]	1-3/4 [44]	2-7/8 [73]	18 [8]	18 [116]

ENGINEERING SPECIFICATION: ZURNZN415C

Floor and shower drain, Dura-Coated cast iron body with bottom outlet, combination invertible membrane clamp and adjustable collar with seepage slots and "TYPE C" polished, hinged nickel bronze, light-duty strainer.

OPTIONS (Check/specify appropriate options)

PIPE SIZE	(Specify size/type)	OUTLET	'E' BODY HT. DIM.
2-3-4 [51-76-102]	_____	IC Inside Caulk	3-7/8 [98]
2-3-4 [51-76-102]	_____	IG Inside Gasket	3-7/8 [98]
2 [51]	_____	IP Threaded	2-3/8 [60]
3 [76]	_____	IP Threaded	2-5/8 [67]
4 [102]	_____	IP Threaded	2-7/8 [73]
6 [152]	_____	IP Threaded	2-3/4 [70]
2-3-4 [51-76-102]	_____	NH No-Hub	3-7/8 [98]
2-3-4 [51-76-102]	_____	NL Neo-Loc	3-3/4 [95]

PREFIXES

- _____ ZB D.C.C.I. Body Assembly w/ Polished Bronze Top
- _____ ZN D.C.C.I. Body Assembly w/ Polished Nickel Bronze Top*

SUFFIXES

- | | |
|--|--|
| _____ -AR Acid Resisting Epoxy Coated Cast Iron | _____ -TC Neo-loc Test Cap Gasket (2 - 4 [51 - 102] NL Bottom Outlet Only) |
| _____ -CP Chrome-Plated Bronze Top | _____ -U 1 - 3 [25 - 76] High Extension Adapter |
| _____ -G Galvanized Cast Iron | _____ -V Backwater Valve |
| _____ -P Trap Primer Connection (Specify 1/2 [13] or 3/4 [19]) | _____ -VP Vandal-Proof Secured Top |
| _____ -PC Protective Cover | _____ -Y Sediment Bucket |
| _____ -SA Stabilizer Assembly (See Z1035) | _____ -18 Leveling Ring (See Z400-18) |
| _____ -SQ Stabilizer Q-Deck (See Z1035-Q) | _____ -90 90° Threaded Side Outlet Body Assembly (2 [51], 3 [76] Only) |
| _____ -SR Stabilizer Ring | |

* Regularly furnished unless otherwise specified.