

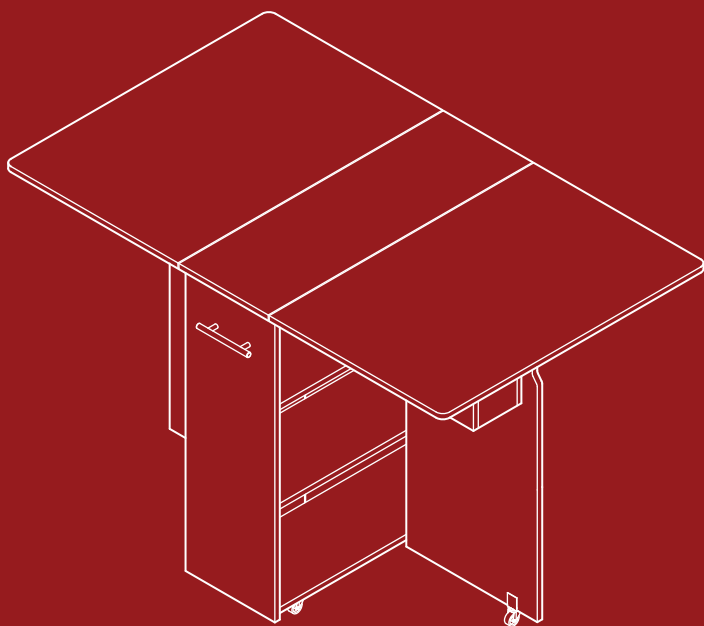

BEST CHOICE
PRODUCTS



INSTRUCTION MANUAL

Mobile Dining Table

Ver. 2

SKY6581 + SKY6582 + SKY7631 + SKY7632 + SKY7633

! NOTICE

Please retain these instructions for future reference.

- Please do not exceed the weight limitations of this item.
- Do not stand on or use any part of this item as a step ladder.
- Firmly secure all bolts, screws, and knobs before use.
- Reconfirm that all bolts, screws, and knobs are secure every 90 days.
- Do not use or store this item in the proximity of open flame or flammable/combustible chemicals.
- If any parts are missing, broken, damaged, or worn, stop using this item until repairs are made and/or factory replacement parts are installed.
- Do not use this item in a way inconsistent with the manufacturer's instructions as this could void the product warranty.
- This product is intended for residential use only.

TOOLS REQUIRED



PHILLIPS
SCREWDRIVER



ELECTRIC DRILL
(RECOMMENDED)



ALLEN WRENCH
(PROVIDED)



FLATE HEAD
SCREWDRIVER



HAMMER
(RECOMMENDED)



5 LBS CUBBY
CAPACITY



2 PERSON
ASSEMBLY



UP TO 90 MIN.
ASSEMBLY



100 LBS
MAIN TABLE
CAPACITY



50 LBS TABLE
EXTENSION (X2)
CAPACITY



100 LBS
SHELF
CAPACITY

HARDWARE

A Ø6 X 35MM
CAM BOLT

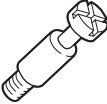

34 PCS

B Ø15 X 10MM
CAM LOCK



34 PCS

C Ø8 X 30MM
DOWEL



40 PCS

D Ø3 X 12MM
SCREW



76 PCS

E Ø4 X 22MM
BOLT



4 PCS

F Ø4 NUT



4 PCS

G CASTER SET

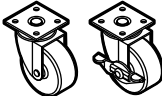

2 SETS

H DOOR CASTER



2 PCS

HARDWARE

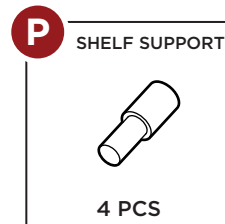
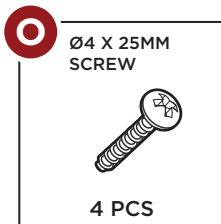
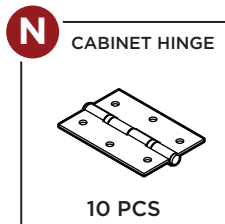
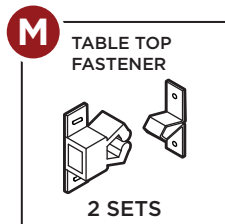
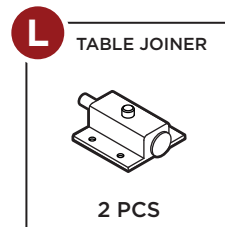
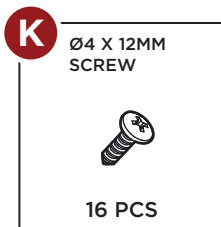
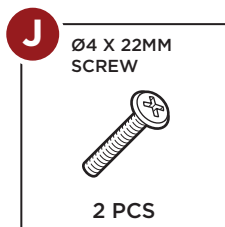
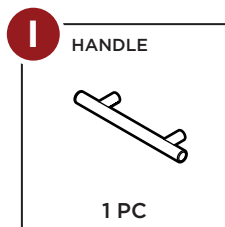

TIGHTENING CAMLOCKS

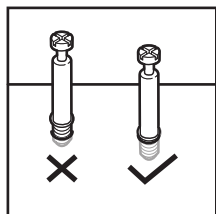

1. Screw cam bolt in completely.

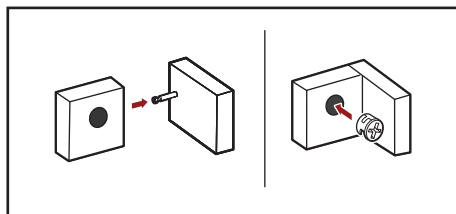

2. Insert cam bolt and cam lock into designated holes.

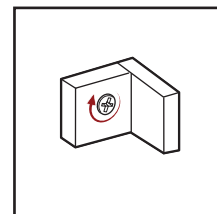

3. Screw cam lock clockwise to secure cam bolt.

PARTS

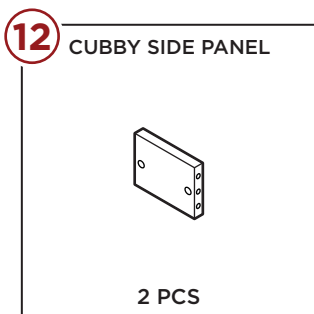
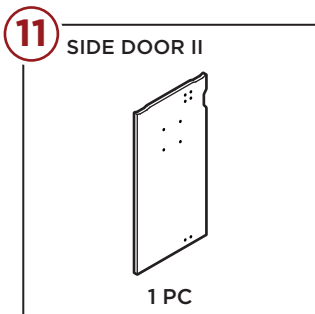
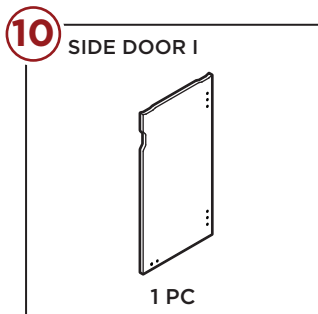
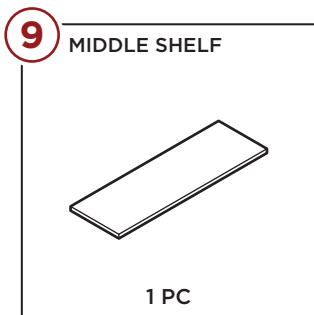
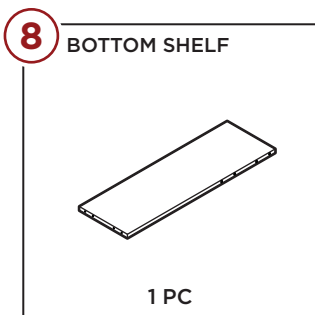
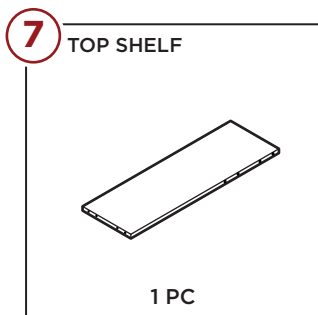
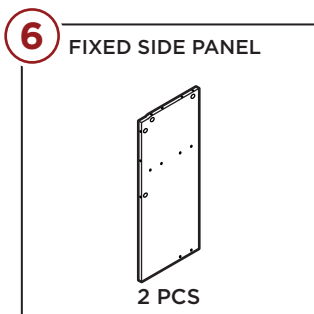
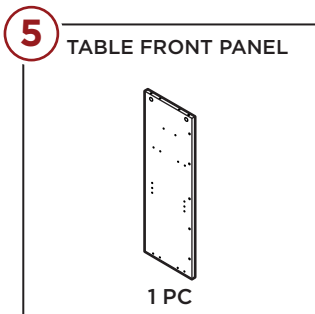
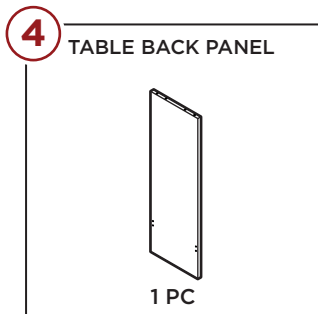
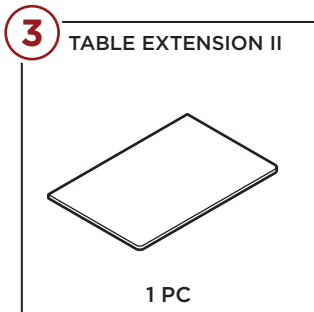
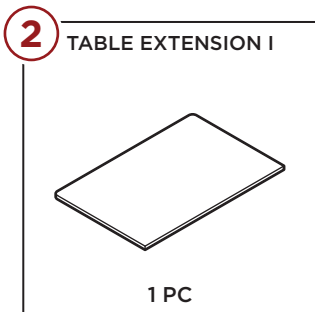
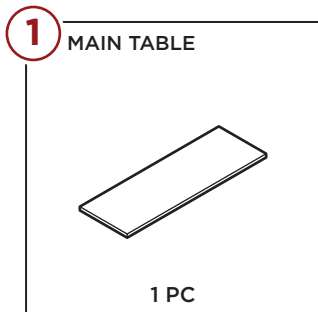

PARTS

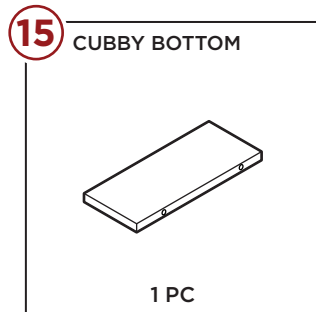
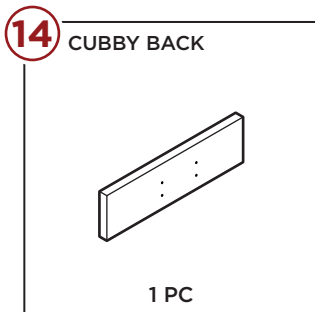
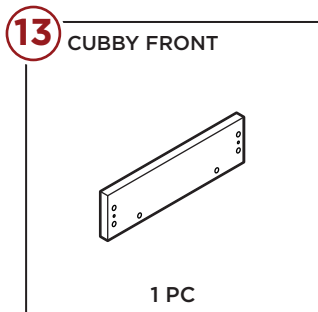

PRODUCT ASSEMBLY

1

Insert seven **part A cam bolts** each into the **part 4 table back panel** and the **part 5 table front panel**, fourteen bolts total.

Attach the **part I handle** to the **part 5 table front panel** with two **part J screws**.

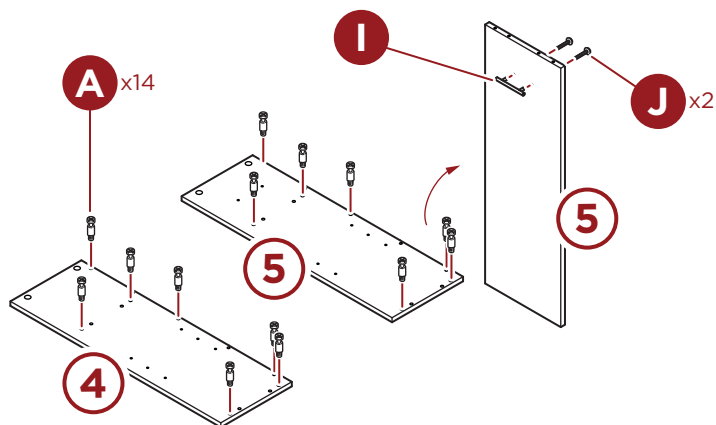

2

Locate two **part 6 fixed side panels** and insert four **part A cam bolts** into each panel, eight bolts total.

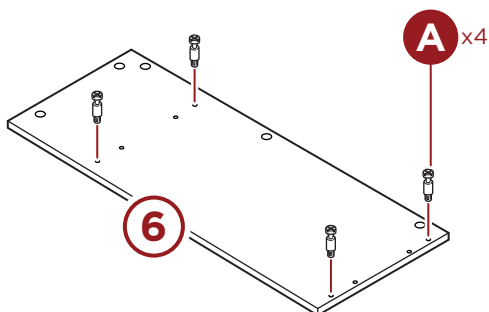

PRODUCT ASSEMBLY

3

Insert four **part C dowels** each into the **part 7 top shelf** and **part 8 bottom shelf**, eight dowels total. Attach the **part 7 & 8 shelves** to one **part 6 fixed panel**.

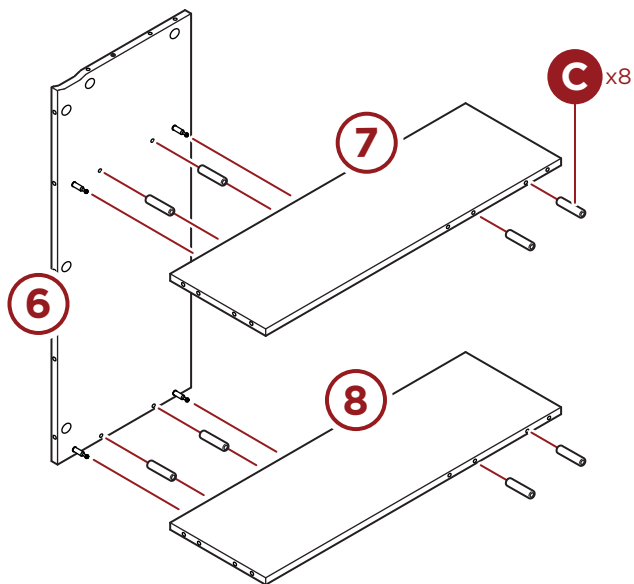

4

Attach the **part 6 fixed panels**, then insert four **part B cam locks** into each shelf panel, eight locks total, then turn to secure.

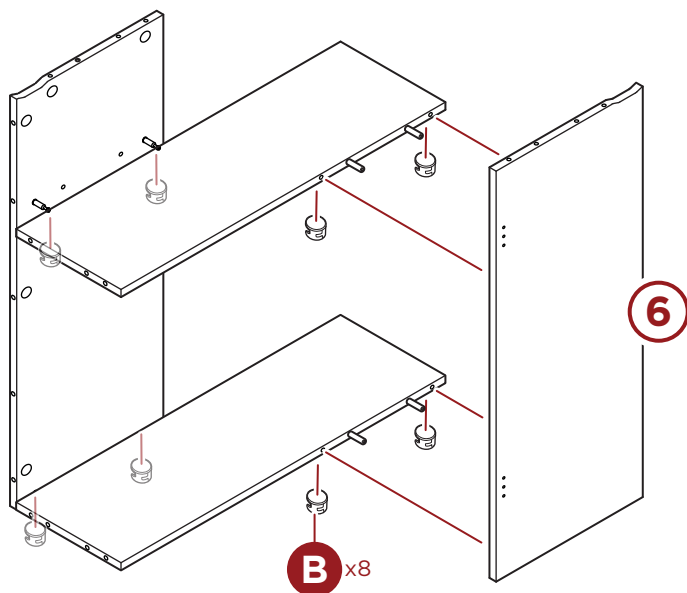

PRODUCT ASSEMBLY

5

Place the assembly on its side, then insert six **part C dowels** into the **part 4 back panel**, then attach to the **part 6, 7, and 8 panels**.
Insert two **part B cam locks** into the **part 8 bottom shelf**, twist to secure.
Insert two **part B cam locks** into the **part 7 top shelf**, twist to secure.

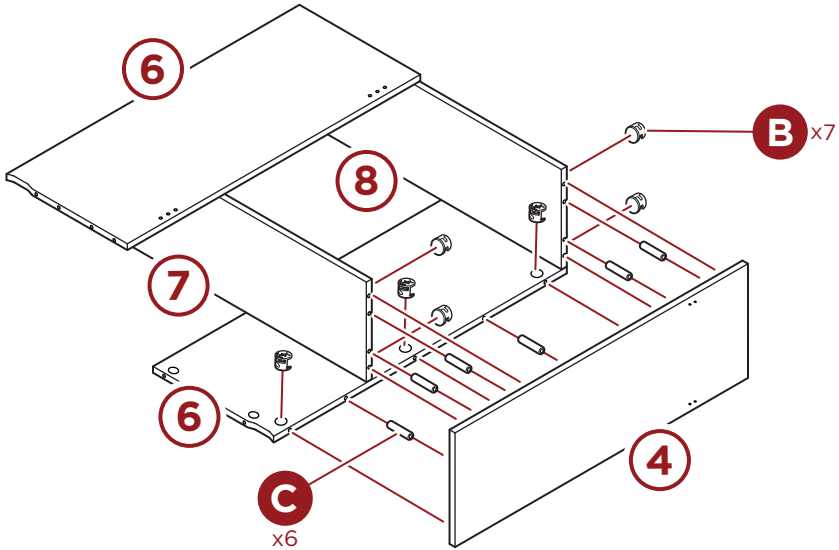

6

Place the assembly on its back (**part 4 panel**), then insert six **part C dowels** into the **part 5 front panel**, then attach to the **part 6, 7, and 8 panels**.
Insert two **part B cam locks** into the **part 8 bottom shelf**, twist to secure.
Insert two **part B cam locks** into the **part 7 top shelf**, twist to secure.

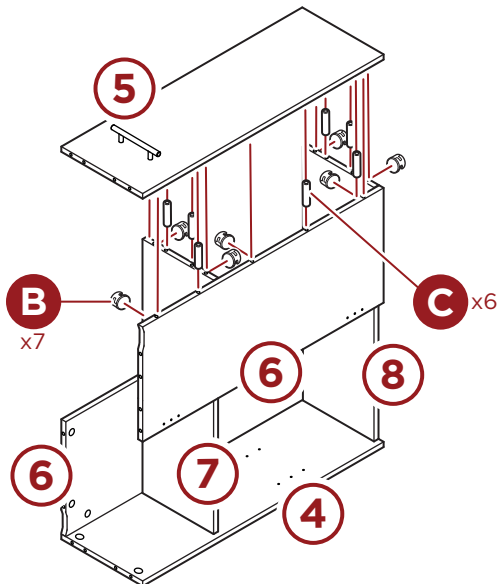

PRODUCT ASSEMBLY

7

Flip the assembly so the bottom of the **part 8 shelf** is facing upward. Attach two **part G caster sets** to the bottom of the **part 8 shelf** with sixteen **part K screws**, four screws per caster.

NOTE: Arrange the casters in the four corners of the panel so that the locking and non-locking casters are on opposite angles.

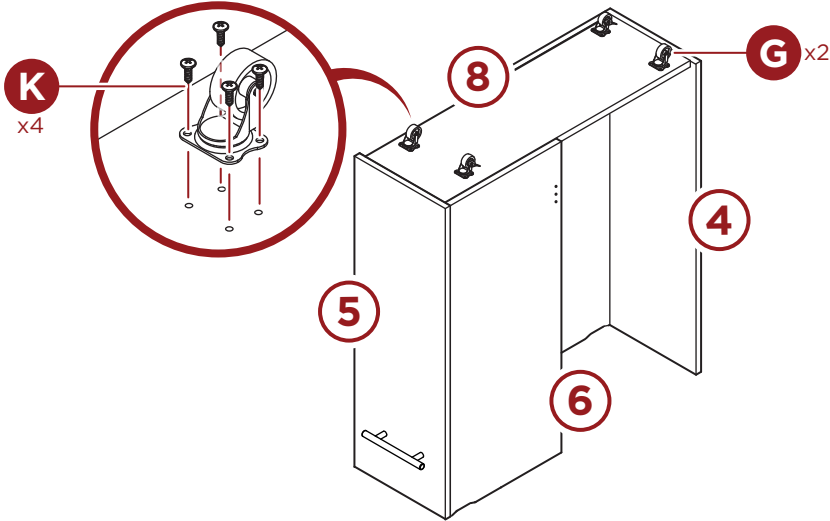

8

Attach two **part N hinges** to the **part 10 right side door** with six **part D screws**, three screws per hinge.

Attach two **part N hinges** to the **part 11 left side door** with six **part D screws**, three screws per hinge.

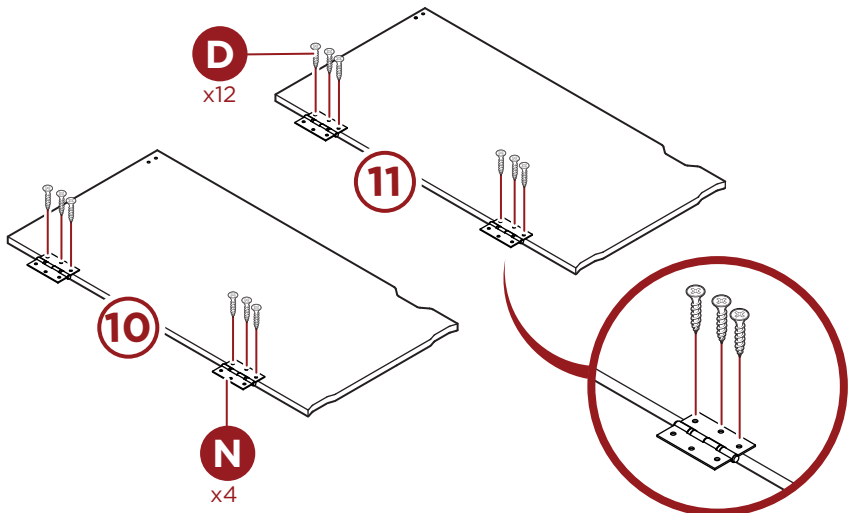

PRODUCT ASSEMBLY

9

Insert two **part A** cam bolts and four **part C** dowels into the **part 14** cubby back.
Insert two **part B** cam locks into two **part 12** cubby sides, four locks total.
Attach the **part 12** cubby sides to the **part 14** cubby back then turn the locks to secure.

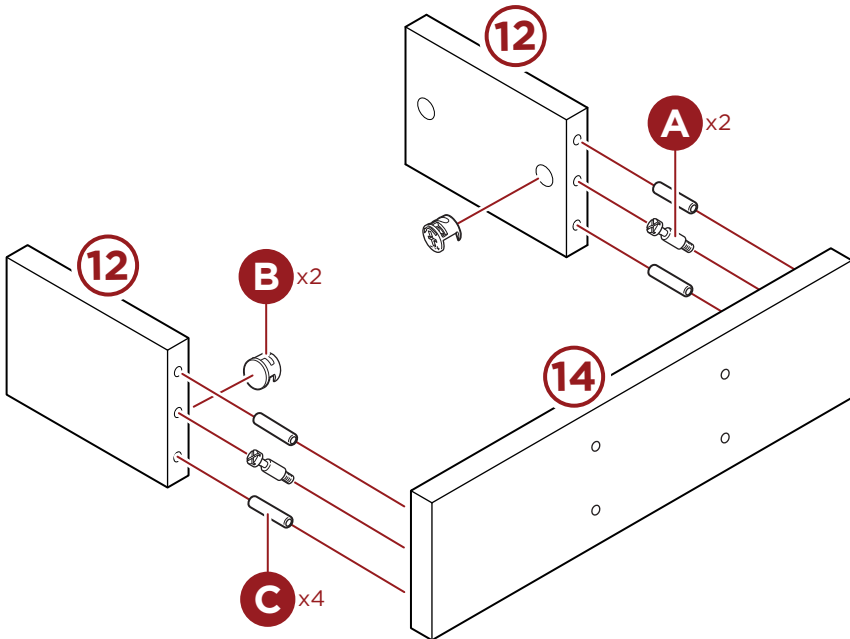

PRODUCT ASSEMBLY

10

Secure the **part 14 cubby back** to the **part 11 left side door** with four **part O screws**, then attach the **part 15 cubby bottom** with two **part C dowels**.

Insert two **part A cam bolts** into the **part 13 cubby front**, then attach to the **part 15 cubby bottom**, and **part 12 cubby sides** with six **part C dowels**, two dowels per panel. Turn the locks to secure.

Attach one **part L table joiner** to the **part 10 and 11 side doors** with eight **part D screws**, four screws per joiner.

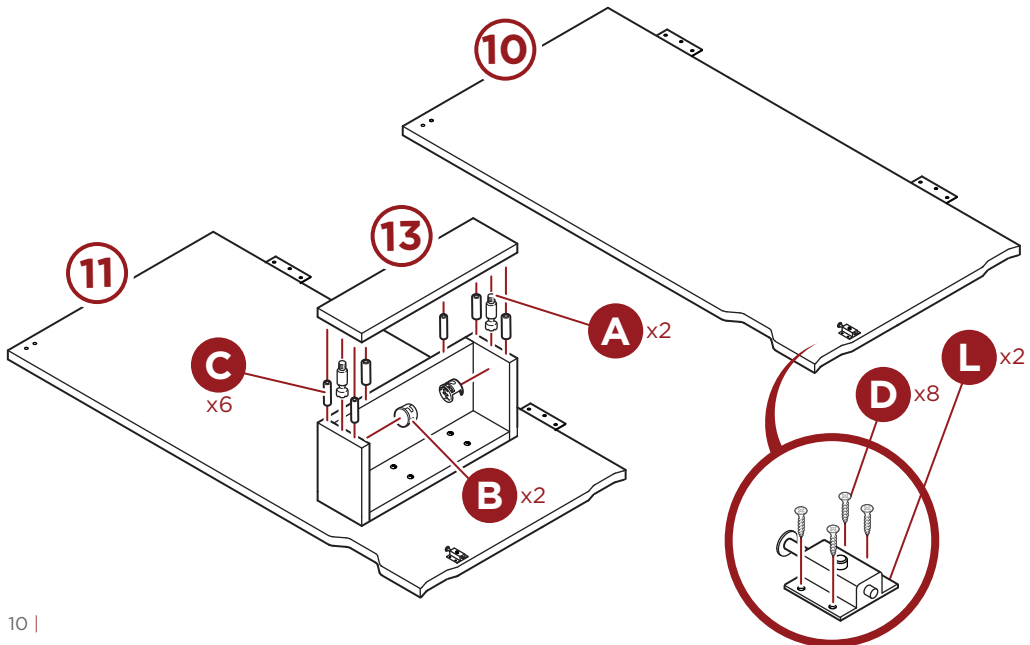
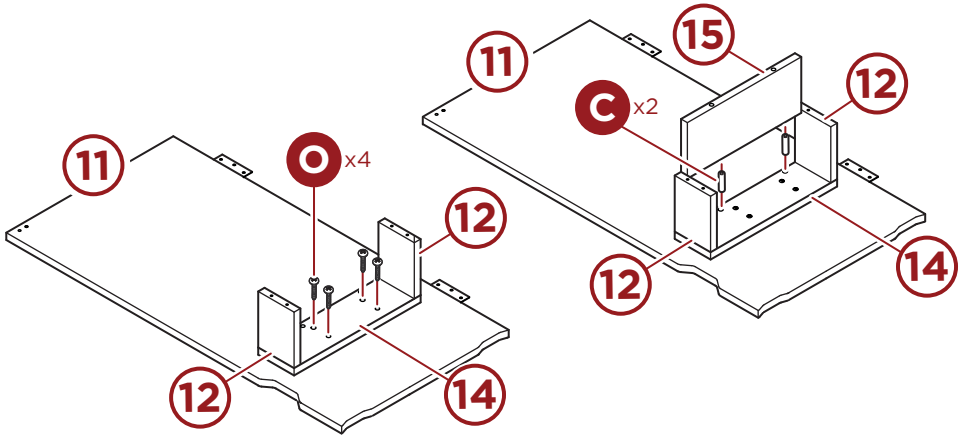

PRODUCT ASSEMBLY

11

Attach the **part 10 right side door** by securing the open hinges to the **part 6 fixed panel** with six **part D screws**.

Attach two **part M table top fasteners (female)** to the **part 4 back panel** with four **part D screws**.

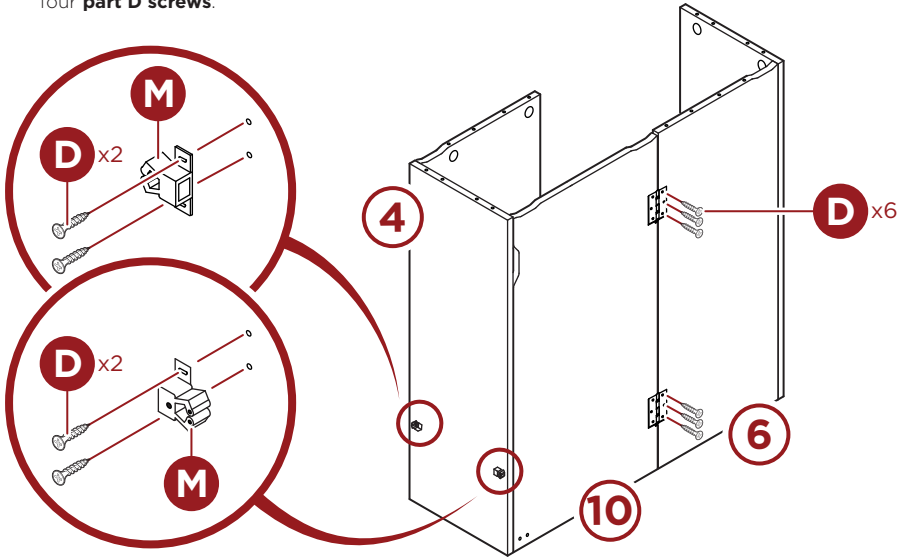

12

Attach the **part 11 left side door** by securing the open hinges to the **part 6 fixed panel** with six **part D screws**.

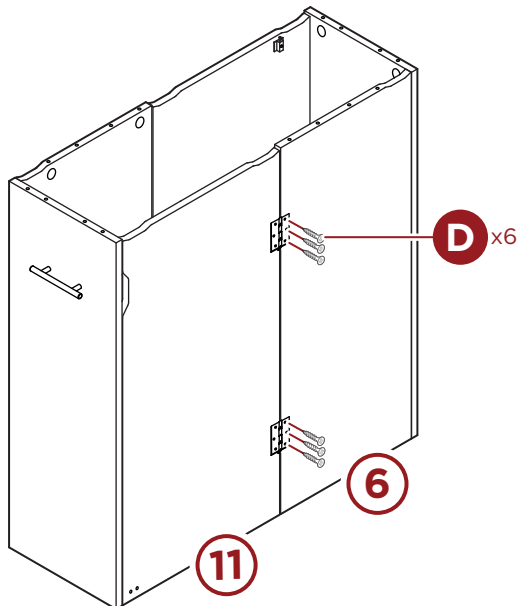

PRODUCT ASSEMBLY

13

Attach two **part M table top fasteners (male)** to the **part 2 & 3 table extensions** with four **part D screws**.

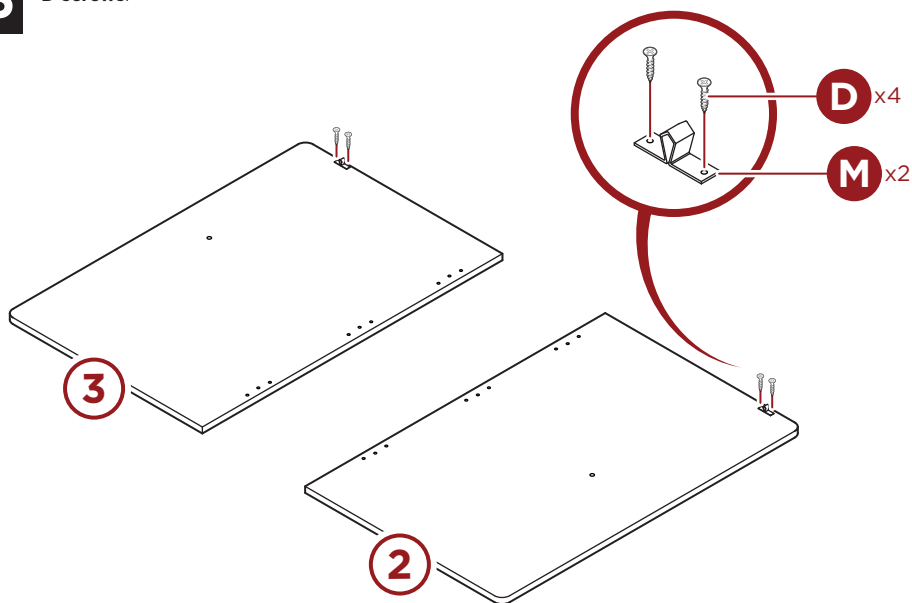

14

Insert eight **part A cam bolts** into the bottom of the **part 1 main table**, then attach six **part N hinges** with eighteen **part D screws**.

Secure the **part 2 & 3 table extensions** by securing them to the open hinges attached to the **part 1 main table** with eighteen **part D screws**.

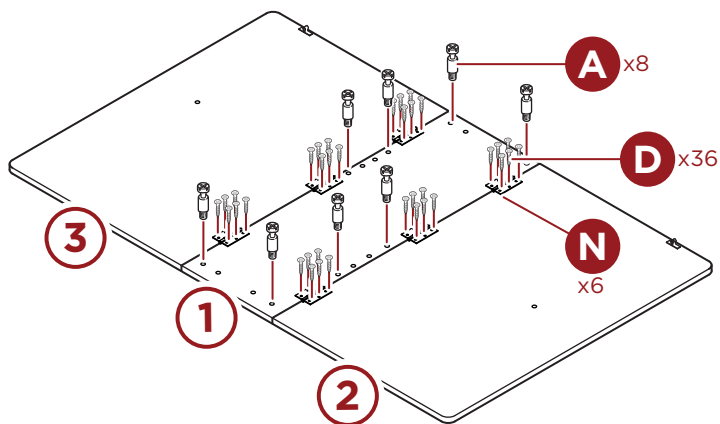

PRODUCT ASSEMBLY

15

Open the **part 10 & 11 doors**, then attach two **part H door casters** with four **part E bolts** and four **part F nut** per caster.

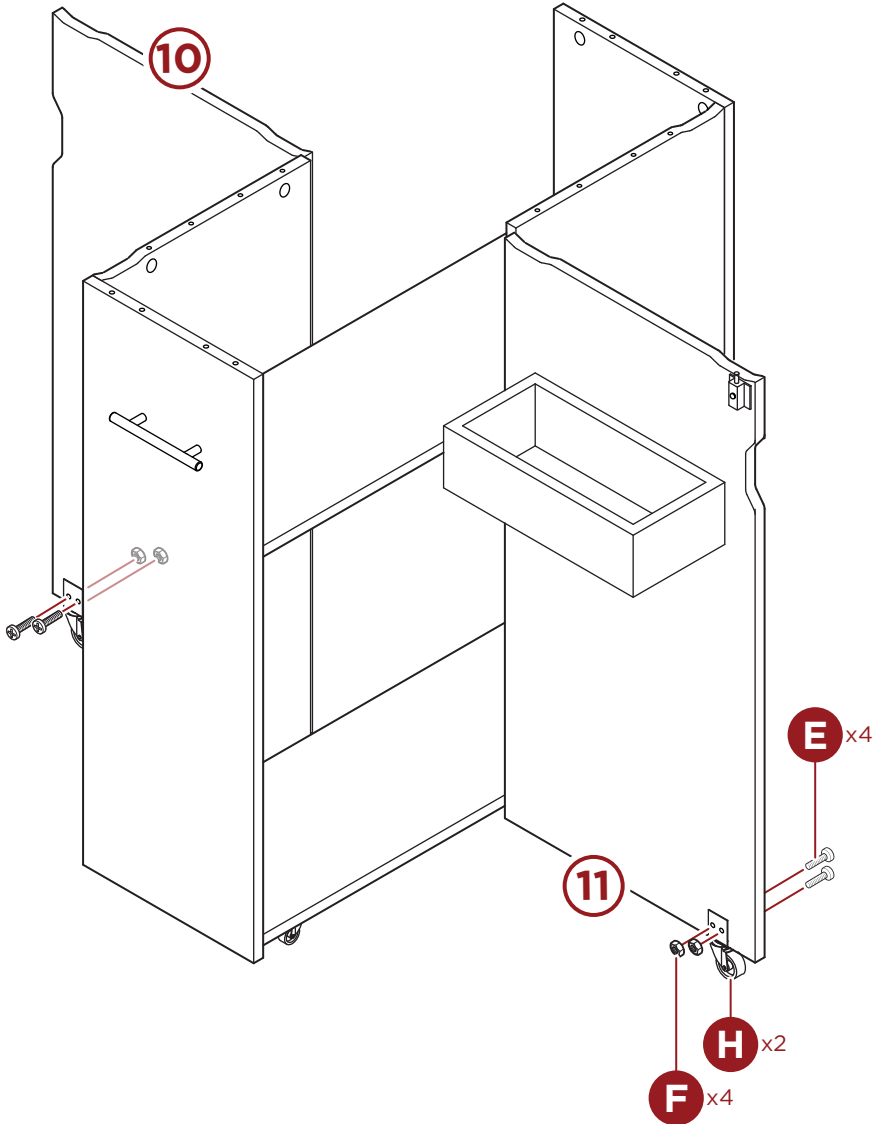

PRODUCT ASSEMBLY

16

Insert two **part B cam locks** into each **part 6 fixed side panel**, four locks total.
Insert two **part B cam locks** in the **part 5 front**, and the **part 4 back panel**, four locks total.
Attach the table top assembly with eight **part C dowels**, then secure by turning the cam locks.

NOTE: We recommend a second person lowers the table top assembly while the other checks the alignment.

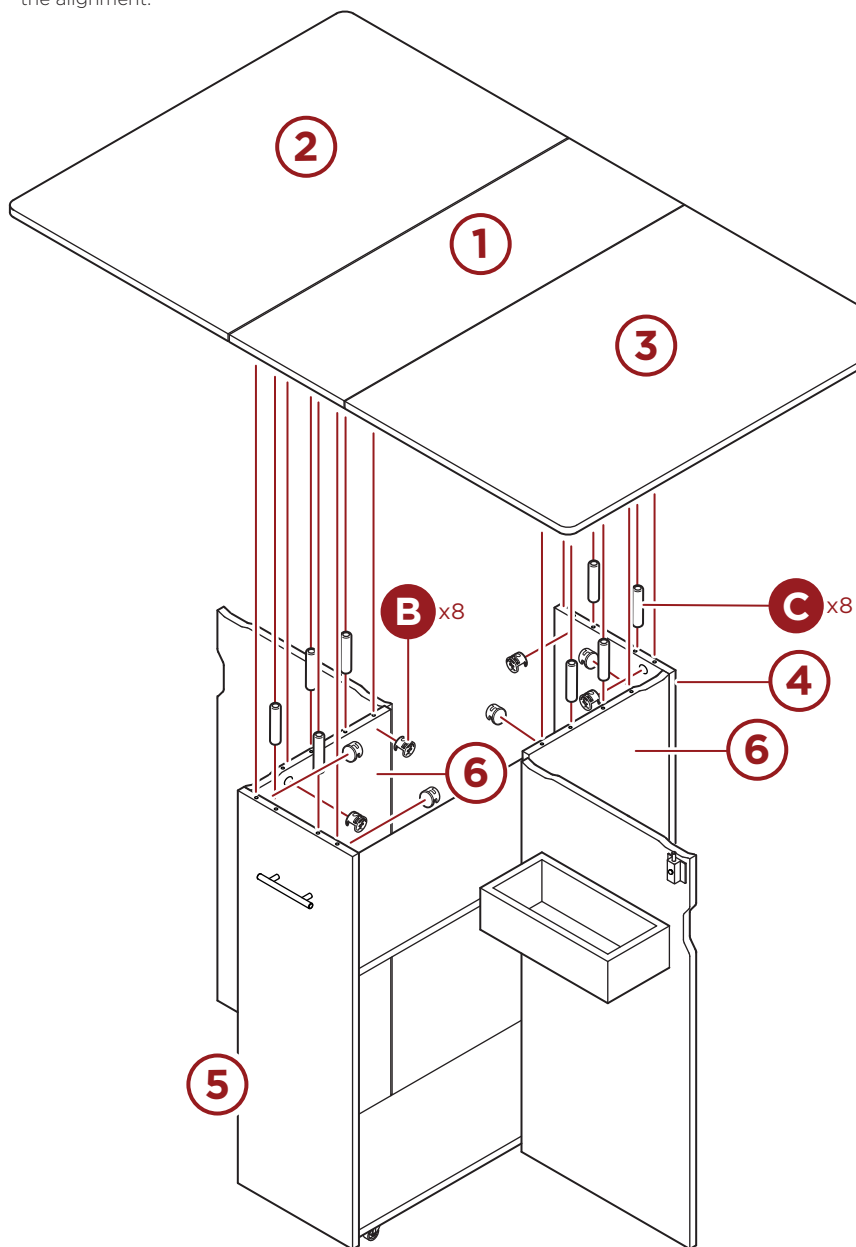

PRODUCT ASSEMBLY

17

Insert four **part P shelf supports** into the **part 4 & 5 front and back panels**.
Place the **part 9 middle shelf** onto the supports.
Open the **part 2 & 3 side panels** and secure them with the **part L table joiners**.

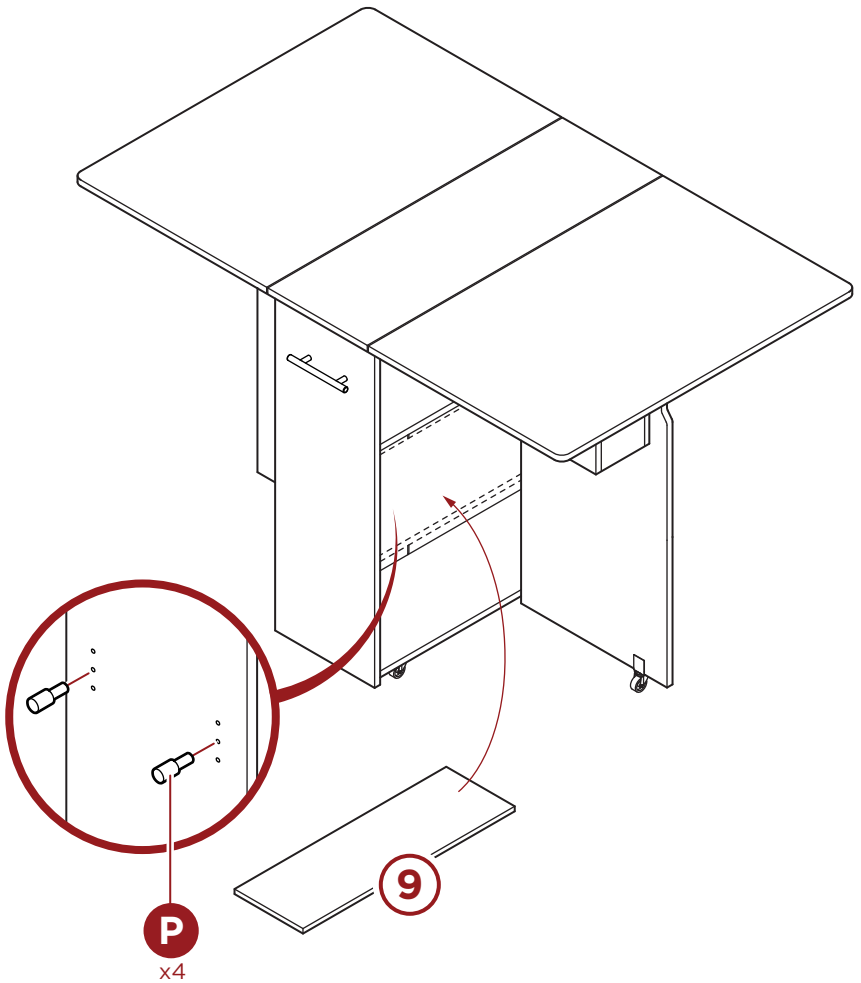



HELP CENTER



Question about your product? We're here to help. Visit us at:

help.bestchoiceproducts.com



Chat Support



Product Inquiry



Orders FAQ



Product Assembly



Returns & Refunds

PRODUCT WARRANTY INFORMATION

All items can be returned for any reason within 60 days of the receipt and will receive a full refund as long as the item is returned in its original product packaging and all accessories from its original shipment are included. All returned items will receive a full refund back to the original payment method. All returned items will not be charged a re-stocking fee.

All returned items require an RA (Return Authorization) number, which can only be provided by a Best Choice Products Customer Service Representative when the return request is submitted. Items received without an RA may not be accepted or may increase your return processing time. Once an item has been received by Best Choice Products, refunds or replacements will be processed within 5 business days.

All returns must be shipped back to the Best Choice Products Return Center at the customer's expense. If the reason for return is a result of an error by Best Choice Products then Best Choice Products will provide a pre-paid shipping label via email. Boxes for return shipping will not be provided by Best Choice Products, and is the customer's responsibility to either use the original shipping boxes or purchase new boxes.

Pictures may be required for some returns to ensure an item is not damaged prior to its return. Items returned are not considered undamaged until they are received by Best Choice Products and verified as such. All damages to items are the customer's responsibility until the item has been received by and acknowledged by Best Choice Products as undamaged.

© Best Choice Products, Inc. All rights reserved. Distributed by Best Choice Products, Inc. Tustin, CA 92780



WARNING

Manufacturer and seller expressly disclaim any and all liability for personal injury, property damage or loss, whether direct, indirect, or incidental, resulting from the incorrect attachment, improper use, inadequate maintenance, unapproved modification, or neglect of this product.