

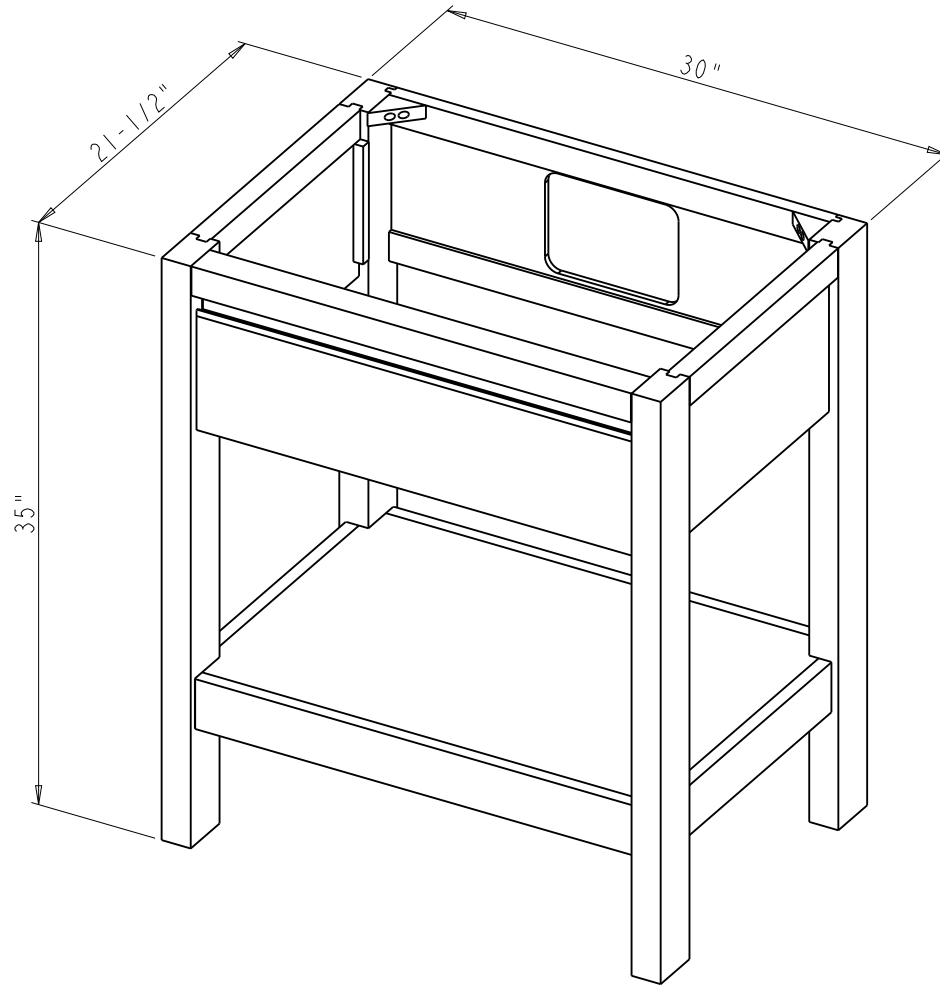

Specification:

1. Finish: See Table
2. Hardware: See Table
3. Hinge: 700.0535.25 + 600.1234.05 (2 set)
4. Lid Stay (1 pcs)
5. The tolerance is +/- 1/8"

Item number	Finish	Deco Hardware	
		Item number	Qty
VN2JUB-30-DW-NT	Dark Walnut	Gola-style hardware-SBZ	1
VN2JUB-30-GR-NT	Grey	Gola-style hardware-MB	1
VN2JUB-30-NO-NT	Natural Oak	Gola-style hardware-MB	1
VN2JUB-30-WG-NT	Weathered Grey	Gola-style hardware-MB	1
VN2JUB-30-WH-NT	White	Gola-style hardware-MB	1

 <p>PROPRIETARY AND CONFIDENTIAL</p> <p>THE INFORMATION CONTAINED IN THIS DRAWING IS THE SOLE PROPERTY OF HARDWARE RESOURCES INC. ANY REPRODUCTION IN PART OR AS A WHOLE WITHOUT THE WRITTEN PERMISSION OF HARDWARE RESOURCES INC. IS PROHIBITED.</p> <p>DO NOT SCALE DRAWING</p>	ITEM#: VN2JUB-30	MATERIAL:	
	FINISH:	WEIGHT: 9	
	TOLERANCE UNLESS OTHERWISE SPECIFIED: X ±0.20 X.X ±0.10 X.XX ±0.05 ANGULAR: ±0.5°	UNITS: DRAWN BY: <i>Hugo.cai</i>	DATE: <i>May-10-22</i>
	SIZE: SHEET:	APPROVED BY: RELEASE LEVEL:	DATE: REVISION:



 PROPRIETARY AND CONFIDENTIAL THE INFORMATION CONTAINED IN THIS DRAWING IS THE SOLE PROPERTY OF HARDWARE RESOURCES INC. ANY REPRODUCTION IN PART OR AS A WHOLE WITHOUT THE WRITTEN PERMISSION OF HARDWARE RESOURCES INC. IS PROHIBITED.	ITEM#: VN2JUB - 30		MATERIAL:		
	FINISH:		WEIGHT: 9		
	TOLERANCE UNLESS OTHERWISE SPECIFIED: X ±0.20 X.X ±0.10 X.XX ±0.05 ANGULAR: ±0.5°		UNITS:	DRAWN BY: <i>Hugo.cai</i>	DATE: <i>May - 10 - 22</i>
	DO NOT SCALE DRAWING		SIZE:	APPROVED BY:	DATE:
		SHEET:	RELEASE LEVEL:	REVISION:	

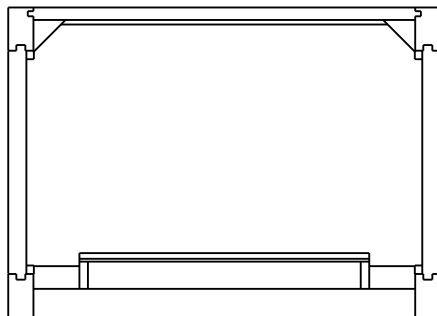
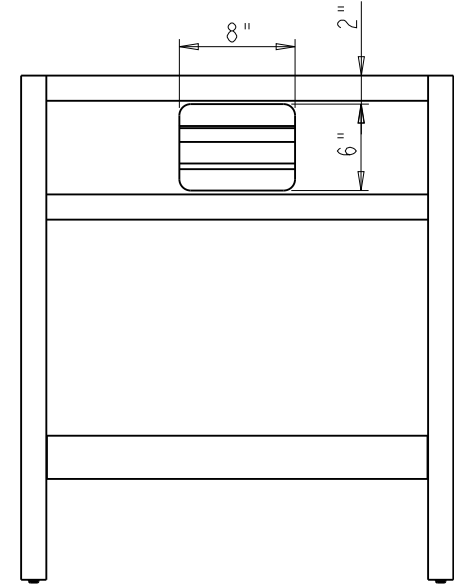
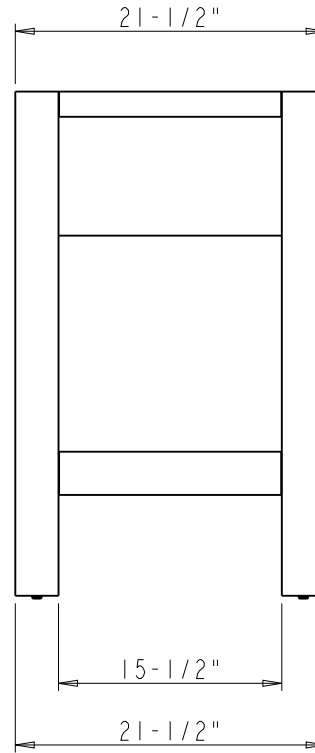
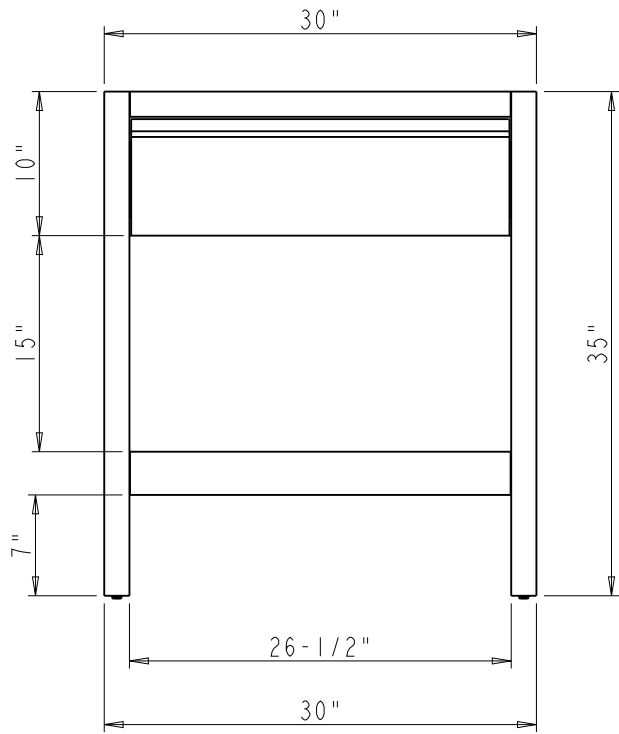

	ITEM#: VN2JUB-30		MATERIAL:		
	FINISH:		WEIGHT:		
<p>PROPRIETARY AND CONFIDENTIAL</p> <p>THE INFORMATION CONTAINED IN THIS DRAWING IS THE SOLE PROPERTY OF HARDWARE RESOURCES INC. ANY REPRODUCTION IN PART OR AS A WHOLE WITHOUT THE WRITTEN PERMISSION OF HARDWARE RESOURCES INC. IS PROHIBITED.</p> <p>DO NOT SCALE DRAWING</p>	UNITS:		DATE:		
	TOLERANCE UNLESS OTHERWISE SPECIFIED: X ±0.20 X.X ±0.10 X.XX ±0.05 ANGULAR: ±0.5°		APPROVED BY:		DATE:
	DRAWN BY: <i>Hugo.cai</i>		RELEASE LEVEL:	REVISION:	
	DATE: <i>May-10-22</i>				