









# HEKMAN

## ASSEMBLY INSTRUCTIONS

23324 - Arm Chair

A HOWARD MILLER COMPANY

A			1Pc
B		5/16" x 12.5 x 8.5mm	4Pcs
C		5/16	10Pcs
D		5/16 x 19mm	10Pcs
E		5/16 x 38mm	2Pcs
F		5/16 x 89mm	4Pcs
G		1/8 x 25mm	2Pcs
H			1Pc

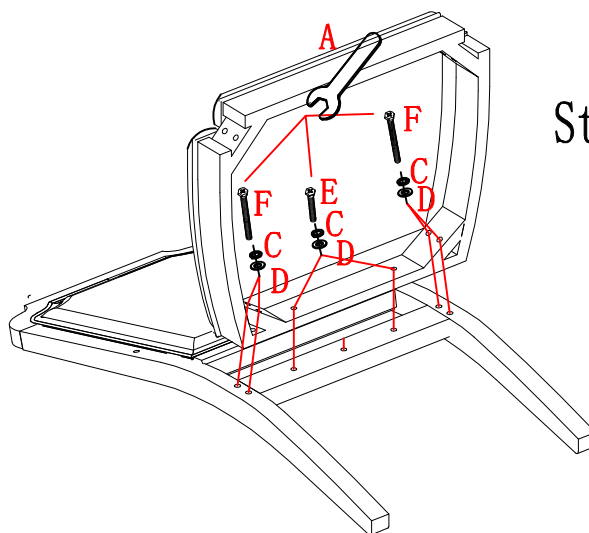

Step 1

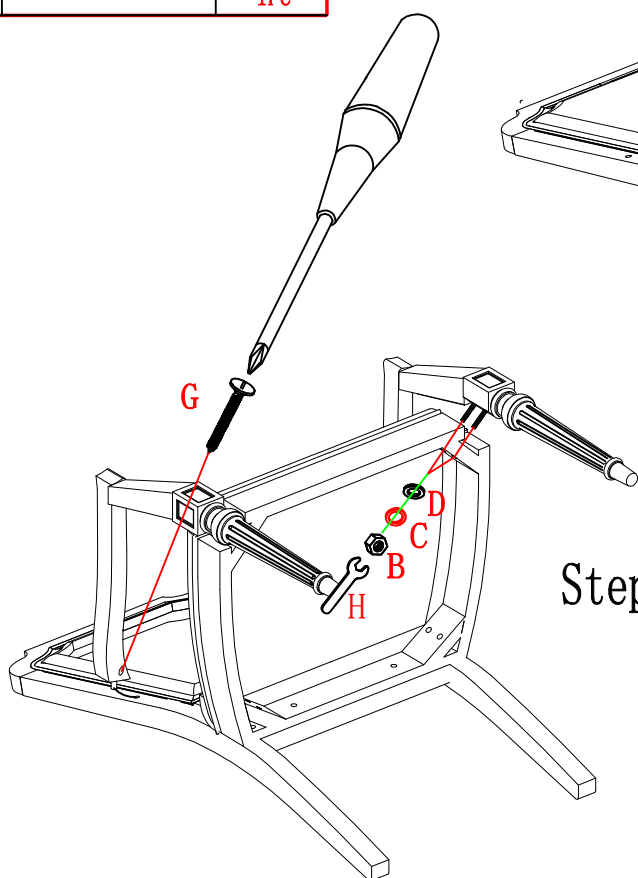

Step 2

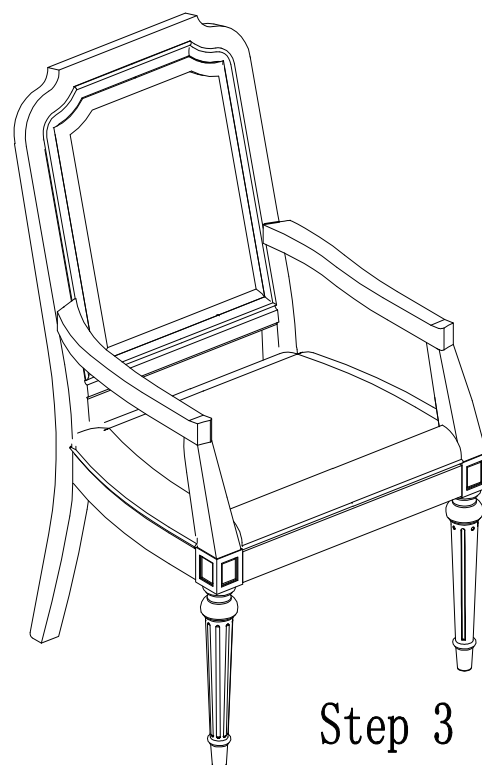

Step 3

Assemble the chair on soft and clean surface to prevent scratching. Loosen screws holding upholstered seat to seat apron assembly, it's not necessary to remove the seat completely.

Step 1: Assemble the back frame and the chair seat together with Bolt (E), Washer (C) and Lock washer (D) using Wrench (A).

Step 2: Assemble the front legs to the chair with Nut (B), Washer (C) and Lock washer (D) using Wrench (A). Attach the arm to back legs with screw (G). Do not tighten screw or nuts completely

Step 3: Set the chair upright on a flat surface. Adjust front legs so all four chair legs touch the floor, tighten nut completely on front legs. (The seat cushion may need to be loosen to adjust front legs).

Step 4: Tighten screw that attached arms to back legs.

MADE IN VIETNAM